



ASSEMBLY INSTRUCTION FOR 24920 DINING TABLE

HARDWARE LIST			
NO.	ITEM	DESCRIPTIN	QTY.
1		Bolt M8X25 MM	16
2		Flat washer M8X22 MM	16
3		Wrench	1

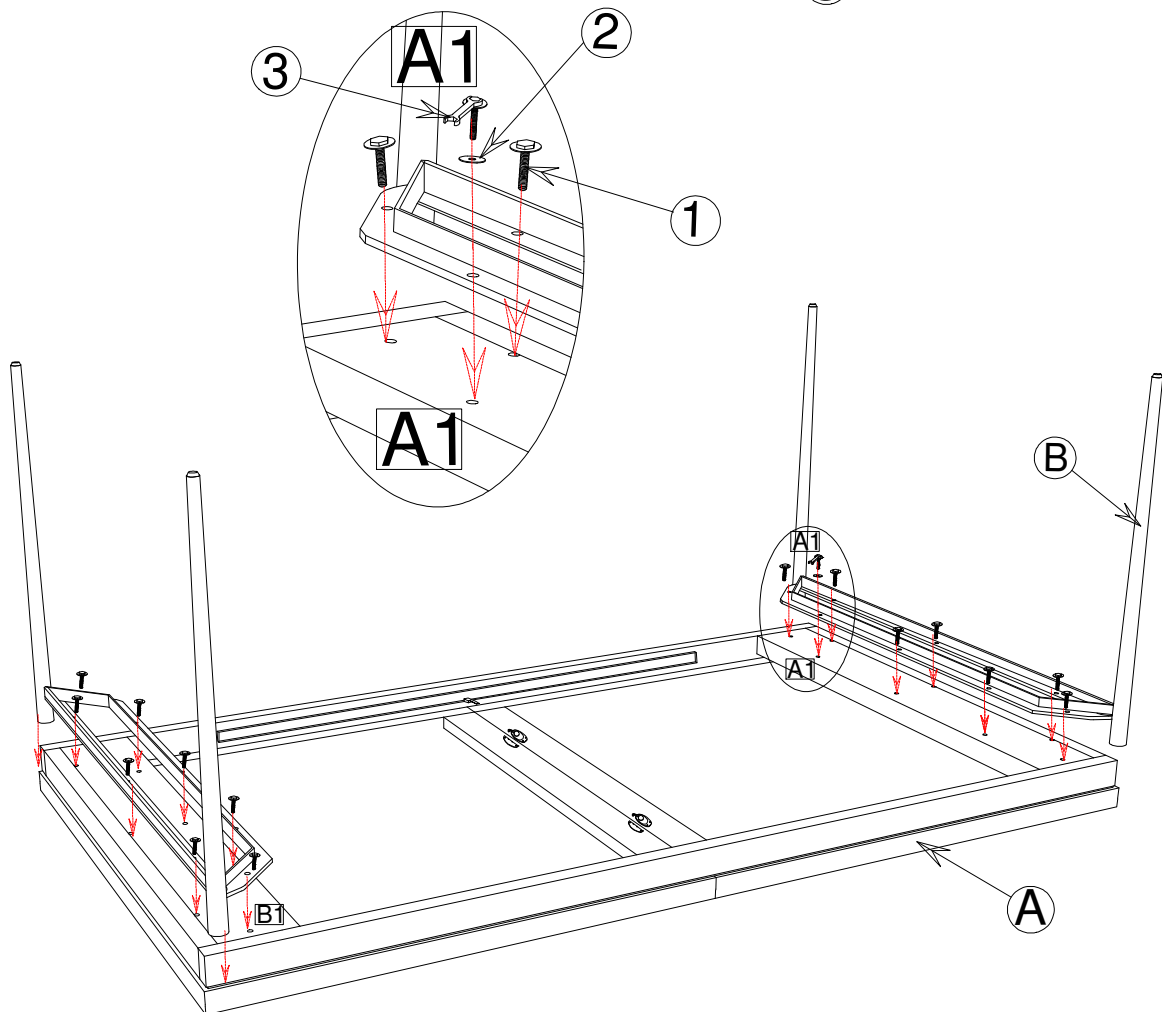
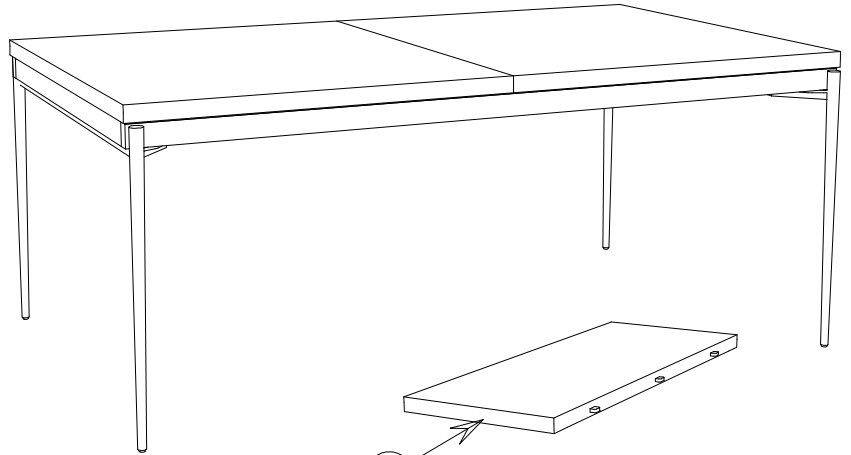

TO ASSEMBLY :

- STEP 1 : Unpack dining table and turn the top (A) upside down on a soft clean surface.
- STEP 2 : Align holes in legs (B) with holes on bottom of top (A) and slide it into position.
- STEP 3 : Assemble the Top(A) with Legs (B) matching the alphabets (A1-A1) & (B1-B1) .
- STEP 4 : Thread all the flat washer(2) , bolt (1) to leg (B) . When all the bolts are half tighten then follow steps 5.
- STEP 5 : Tighten all bolts fully with wrench (3) & (4) then carefully turn the dining table upright.

ASSEMBLY INSTRUCTION FOR 24920 DINING TABLE

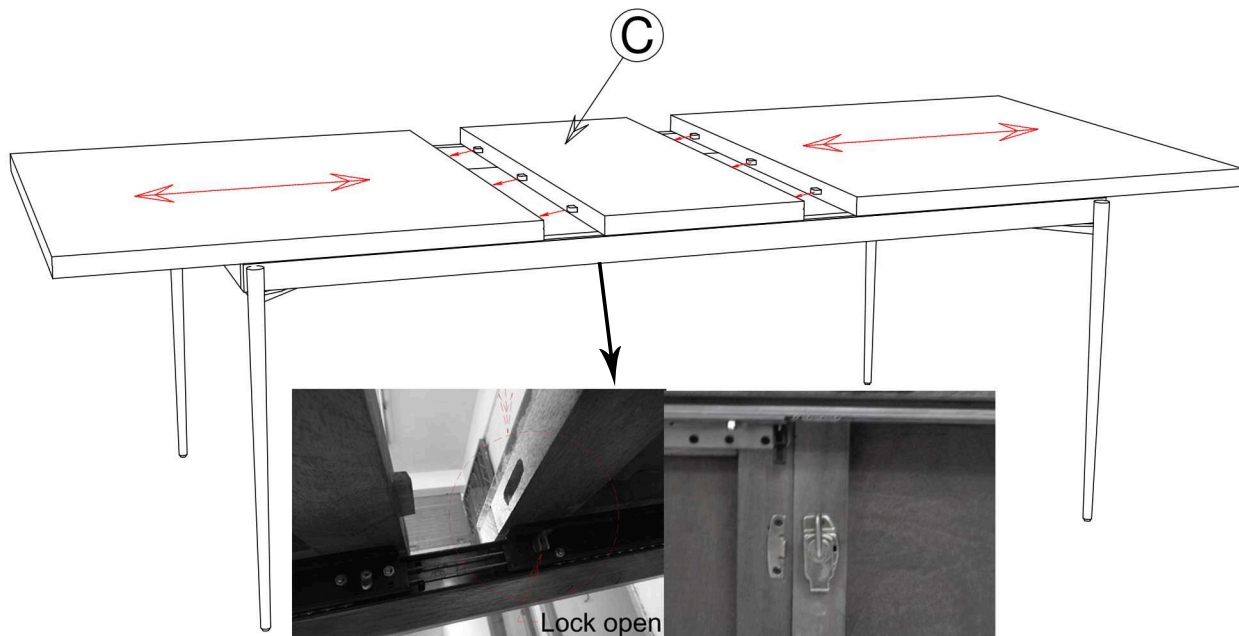
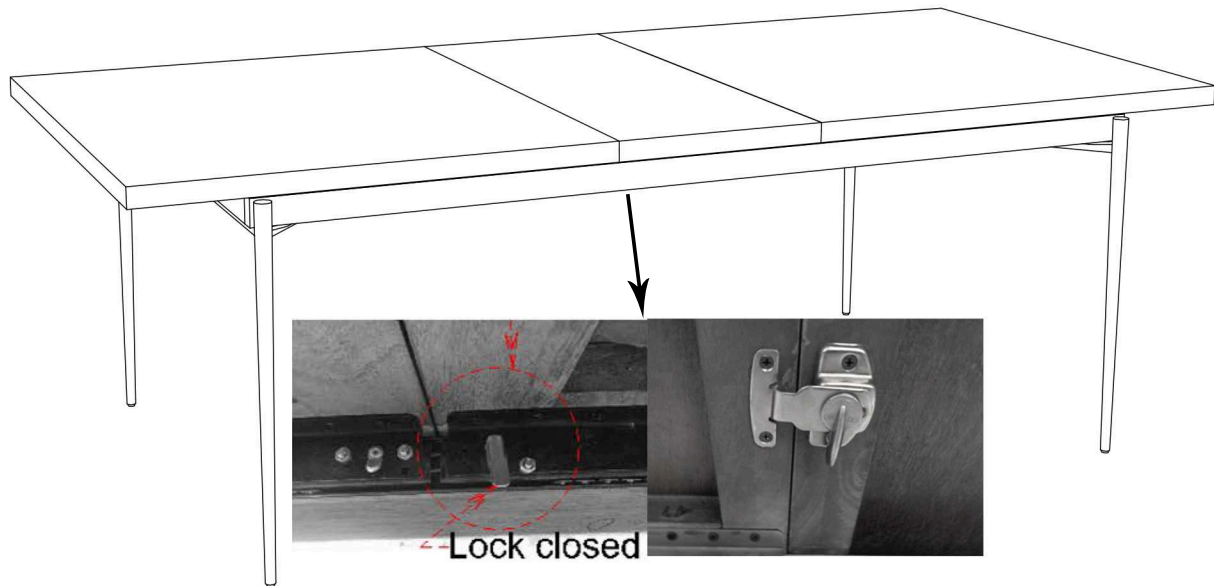

TO ASSEMBLY :

- STEP 5 :Unlock table slides.
- STEP 6 : Pull left & right side sliding top of the table away from the center.
- STEP 7 :Place the extension top (C) in the center of the table.
- STEP 8 : Push the left and right sliding top of table towards the center.
- STEP 9 : Lock table slides.