



BERNINA 740



made to create **BERNINA**

Dear BERNINA customer



Congratulations! You have decided on BERNINA and therefore on a product which will delight you for years. For more than 100 years our family company has attached greatest importance to satisfied customers. As for me, it is a matter of personal concern to offer you Swiss development and precision at the height of perfection, future-orientated sewing technology and a comprehensive customer service.

The BERNINA 7-series consists of various ultramodern machines, whose development not only focused the highest demands on technique and the ease of use but also considered the design of the product. After all we sell our products to creative people like you, who do not only appreciate high quality but also form and design.

Enjoy the creative sewing, embroidering and quilting on your new BERNINA 740 and keep informed about the various accessories at www.bernina.com. On our homepage you will also find a lot of inspiring sewing instructions, to be downloaded for free.

Our highly trained BERNINA dealers will provide you with more information on service and maintenance offers.

I wish you lots of pleasure and many creative hours with your new BERNINA.

A handwritten signature in black ink, reading "H.P. Ueltschi". The signature is written in a cursive, flowing style.

H.P. Ueltschi

Owner

BERNINA International AG

CH-8266 Steckborn

Edition notice

Graphics

www.sculpt.ch

Text, Setting and Layout

BERNINA International AG

Photos

Patrice Heilmann, Winterthur

Order number

2014/09 en 036044.50.04

1st Edition

Copyright

2014 BERNINA International AG

All rights reserved: For technical reasons and for the purpose of product improvements, changes concerning the features of the machine can be made at any time and without advance notice. The supplied accessory can vary depending on the country of delivery.

Contents

IMPORTANT SAFETY INSTRUCTIONS	11
2 My BERNINA	14
2.1 Introduction	14
2.2 Further information	14
2.3 Key to signs	14
2.4 Overview	15
Overview front controls	15
Overview front	16
Overview sideways	17
Overview back	18
2.5 Included accessories	19
Use of the power cable (USA/Canada only)	20
Foot control (USA/Canada only)	21
Presser feet	21
Accessory box	22
2.6 Overview Selection Menu on the left (External Functions/Views)	23
2.7 Overview Selection Menu below (System settings)	23
2.8 Buttons and icons	23
2.9 Needle, Thread, Fabric	24
Thread selection	26
Example for needle description	26
Needle/thread combination	26
3 Preparation	28
3.1 Accessory box	28
Accessory box free standing	28
Storing accessories	28
3.2 Connection and Switching on	29
Connecting the foot control	29
Connecting the machine	29
Attaching the lever of the Free Hand System	30
Fixing the touchscreen pen	30
Switching the machine on	30
3.3 Foot control	30
Sewing speed control	30
Raising/Lowering the needle	31
3.4 Spool holder	31
Installing the spool holder	31
Inserting foam pads	32
Positioning the spool disc	32
Using a spool net	32
3.5 Free arm	33
Adjusting the feed dog	33
Using the slide-on table	33
3.6 Presser foot	34

	Adjusting the presser position via the lever of the Free Hand System	34
	Adjusting the presser foot position via the button Presser foot up/down	34
	Changing the presser foot	34
	Displaying the presser foot	35
	Adjusting the presser foot pressure	35
3.7	Adjusting the feed dog	36
3.8	Checking the filling level of the bobbin thread	36
3.9	Needle and stitch plate	36
	Adjusting the needle position up/down	36
	Adjusting the needle position left/right	36
	Needle stop up/down (permanent)	36
	Changing the needle	37
	Selecting the needle	37
	Select the needle type and the needle size	37
	Changing the stitch plate	38
	Selecting the stitch plate	38
3.10	Threading	39
	Threading preparation	39
	Threading the upper thread	39
	Threading the double needle	42
	Threading the triple needle	43
	Winding the bobbin thread	43
	Threading the bobbin thread	44
3.11	Calling up the Tutorial	47
3.12	Calling up the Help	47
3.13	Calling up the Creative Consultant	47
4	Setup-Program	48
4.1	Sewing settings	48
	Adjusting the upper thread tension	48
	Adjusting the maximum sewing speed	48
	Programming the securing stitches	48
	Adjusting the hovering height of the presser foot	48
	Programming the button «Pattern end»	49
	Programming the button «Thread cutter»	49
	Adjusting the presser foot position with needle stop down	50
	Programming the button «Quick reverse»	50
4.2	Selecting personal settings	51
4.3	Monitoring functions	51
	Activating the upper thread indicator	51
4.4	Activating the audio signals	52
4.5	Machine settings	52
	Selecting a language	52
	Adjusting the brightness of the display	53
	Adjusting the sewing light	53
	Calibrating the display	53
	Back to basic settings	54
	Deleting user data	54

	Deleting data from the BERNINA USB Stick (optional accessory).....	55
	Calibrating the Buttonhole foot No. 3A.....	55
	Updating the software.....	56
	Recovering saved data.....	57
	Cleaning the machine.....	57
	Lubricating the machine.....	57
	Checking the Software Version.....	58
	Reviewing the total number of stitches.....	58
	Registering details of the dealer.....	58
	Saving Service data.....	59
5	Creative sewing.....	60
5.1	Overview Sewing functions.....	60
	Selecting a stitch pattern.....	60
5.2	BERNINA Dual Feed.....	61
	Application of the BERNINA Dual Feed.....	61
5.3	Sewing speed control.....	62
5.4	Editing stitch patterns.....	62
	Changing the stitch width.....	62
	Changing the stitch length.....	63
	Adjusting the upper thread tension.....	63
	Correcting the balance.....	64
	Programming pattern repeat.....	64
	Mirror image of stitch patterns.....	64
	Editing stitch pattern length.....	64
	Quick reverse.....	65
	Permanent Quick reverse.....	65
	Backstepping.....	65
5.5	Securing.....	66
	Securing with the button «Pattern end».....	66
	Securing via the icon «Securing».....	66
5.6	Administering stitch patterns.....	66
	Saving settings of stitch patterns.....	66
	Saving stitch patterns in personal memory.....	66
	Overwriting stitch patterns from the personal memory.....	67
	Loading stitch patterns from the personal memory.....	67
	Deleting stitch patterns from the personal memory.....	67
	Canceling alterations.....	67
5.7	Combi mode.....	68
	Overview Combi mode.....	68
	Creating Stitch pattern combinations.....	68
	Saving a stitch pattern combination.....	68
	Loading a stitch pattern combination.....	69
	Overwriting a stitch pattern combination.....	69
	Editing a single stitch pattern.....	69
	Deleting a single stitch pattern.....	70
	Adding a single stitch pattern.....	70
	Mirroring a stitch pattern combination.....	71
	Stitch pattern combination Subdivider 1.....	71
	Stitch pattern combination Subdivider 2.....	71

	Securing a stitch pattern combination.....	72
	Programming pattern repeat.....	72
5.8	Height Compensation of uneven layers.....	72
5.9	Sewing Corners.....	73
5.10	Using eco mode.....	73
6	Practical stitches.....	74
6.1	Overview Practical stitches.....	74
6.2	Sewing straight stitch.....	76
6.3	Securing with the automatic Securing Program.....	76
6.4	Sewing in the zipper.....	77
6.5	Sewing both sides of the zipper from bottom to top.....	78
6.6	Sewing triple straight stitch.....	79
6.7	Sewing Triple zig zag.....	79
6.8	Manual darning.....	80
6.9	Automatic darning.....	82
6.10	Reinforced darning, automatic.....	83
6.11	Finishing edges.....	83
6.12	Sewing Double overlock.....	84
6.13	Narrow edgestitching.....	84
6.14	Wide edgestitching.....	84
6.15	Edgestitching using the seam guide.....	85
6.16	Sewing hem edges.....	85
6.17	Sewing blind hems.....	86
6.18	Sewing visible hems.....	87
6.19	Sewing flat joining seams.....	88
6.20	Sewing basting stitches.....	88
7	Decorative stitches.....	89
7.1	Overview Decorative Stitches.....	89
7.2	Bobbin-Play.....	90
7.3	Sewing cross stitches.....	91
7.4	Pintucks.....	91
	Inserting the cord.....	92
	Sewing Pintucks.....	93
8	Alphabets.....	94
8.1	Overview Alphabet.....	94
8.2	Creating lettering.....	94
8.3	Altering font size.....	95
9	Buttonholes.....	96
9.1	Overview Buttonholes.....	96

9.2	Making use of the height compensation tool.....	97
9.3	Using the compensation plate.....	97
9.4	Marking buttonholes.....	98
9.5	Cord.....	99
	Using cord with the Buttonhole foot with slide No. 3A.....	99
	Using cord with the Buttonhole foot No. 3C (optional accessory).....	100
9.6	Sewing a test sample.....	101
9.7	Determining the buttonhole slit width.....	101
9.8	Determining the buttonhole length.....	102
9.9	Using the stitch counter function.....	102
9.10	Sewing a buttonhole automatically.....	103
9.11	Programming the Heirloom buttonhole.....	104
9.12	Sewing the manual 7-step buttonhole.....	104
9.13	Sewing the manual 5-step buttonhole.....	105
9.14	Cutting the buttonhole open with the seam ripper.....	106
9.15	Cutting open buttonholes with the buttonhole cutter (optional accessory).....	106
9.16	Sewing on buttons.....	106
9.17	Sewing eyelets.....	107
10	Quilting.....	108
10.1	Overview Quilt Stitches.....	108
10.2	Sewing in the Quilting securing Program.....	109
10.3	Sewing handlook quilt stitches.....	109
10.4	Guiding the quilt work freely.....	110
11	BERNINA Stitch Regulator (BSR).....	111
11.1	Using the BSR mode.....	111
11.2	BSR mode 1.....	112
11.3	BSR mode 2.....	112
11.4	BSR function with Straight stitch No. 1.....	112
11.5	BSR function with Zig zag No. 2.....	112
11.6	Sewing preparation.....	112
	Attach the BSR presser foot.....	112
	Changing the presser foot sole.....	113
11.7	Securing.....	114
	Securing in BSR1 mode with the button «Start/Stop».....	114
	Securing in BSR2 mode.....	114
12	Attachment.....	115
12.1	Maintenacance and cleaning.....	115
	Cleaning the display.....	115
	Cleaning the feed dog.....	115
	Lubricating the machine.....	115
	Cleaning the hook.....	116

	Lubricating the hook.....	117
12.2	Troubleshooting.....	119
12.3	Error messages.....	122
12.4	Storage and disposal.....	125
	Storing the machine.....	125
	Dispose of the machine.....	125
12.5	Technical data.....	126
12.6	Overview Stitch patterns.....	126
	Practical stitches.....	126
	Buttonholes.....	126
	Decorative stitches.....	127
	Index	130

IMPORTANT SAFETY INSTRUCTIONS

Please be aware of the following basic safety instructions when using your machine. Before using this machine, read instruction manual carefully.

DANGER!

To reduce the risk of electrical shock:

- Never leave the machine unattended as long as it is plugged in.
- Always unplug the machine from the electrical outlet immediately after using and before cleaning.

Protection against LED radiation:

- Do not view the LED light directly with optical instruments (e.g. magnifier). The LED light corresponds with protection class 1M.

WARNING

To reduce the risk of burns, fire, electric shock or injury to persons:

- Use this machine only for purposes as described in this manual.
- Do not use the machine outdoors.
- Do not use this machine as a toy. Close attention is necessary when this machine is used by or near children.
- The machine can be used by children older than 8 or by people with reduced physical, sensory or mental capabilities or if there is a lack of experience and knowledge how to operate the machine as long as they are supervised or have been given instruction concerning the responsible use of the appliance and are aware of the involved risks.
- Children are not allowed to play with this machine.

- Cleaning and maintenance work must not be carried out by children unless they are supervised.
- Never operate this machine if it has a damaged cord or plug, if it is not working properly, if it has been dropped or damaged, or dropped into water. Contact the nearest authorized BERNINA dealer to arrange further details.
- Only use accessories recommended by the manufacturer.
- Don't use this machine when the ventilation openings are blocked. Keep the ventilation openings free from the accumulation of lint, dust and loose cloth.
- Never insert any objects into any openings of the machine.
- Do not operate the machine where aerosol products (sprays) or oxygen are being used.
- Keep fingers away from all moving parts. Special care is required around the sewing needle.
- Neither pull nor push the fabric while sewing. This can cause needle breakage.
- Turn power switch to «0» when making any adjustments in the needle area, such as threading the needle, changing the needle, threading the hook or changing the presser foot.
- Do not use bent needles.
- Always use the original BERNINA stitch plate. The wrong stitch plate can cause needle breakage.
- To disconnect, turn power switch to «0» then remove the plug from the outlet. Do not unplug by pulling the cord, instead grasp the plug to pull it from the outlet.

- Always disconnect the power plug from the electrical outlet when the covers are removed or opened, when the machine is lubricated or during any other maintenance adjustments mentioned in the instruction manual.
- This machine is provided with double insulation (except USA/Canada). Use only identical replacement parts. See instructions for Servicing of double-insulated products.

Servicing double-insulated products

In a double-insulated product two systems of insulation are provided instead of grounding. No grounding means is provided on a doubleinsulated product, nor should a means for grounding be added to the product. Servicing a double-insulated product requires extreme care and knowledge of the system and should be done only by qualified service personnel. Replacement parts for a double-insulated product must be identical to the original parts in the product. A double-insulated product is marked with the words: «Double Insulation» or «double-insulated».

The symbol may also be marked on the product.

SAVE THESE INSTRUCTIONS!

Appropriate use

Your BERNINA machine is conceived and designed for private household use. It answers the purpose to quilt fabrics as it is described in this instruction manual. Any other use is not considered appropriate. BERNINA assumes no liability concerning consequences resulting from an inappropriate usage.

2 My BERNINA

2.1 Introduction

With your BERNINA 740 you can sew and quilt. Delicate silk or satin fabrics as well as heavy-weight linen, fleece and denim can be sewn without any problems with this machine. Numerous practical as well as decorative stitches and buttonholes are at your disposal.

In addition to this instruction manual, three help programs are provided on the display.

The **Tutorial** gives information and explanations, covering various aspects of sewing and the different stitches.

The **Creative Consultant** informs you about decision support for sewing projects. After entering the kind of fabric and the desired sewing project, suggestions concerning the suitable needle or the appropriate presser foot are displayed.

The **Help Program** contains information about individual stitch patterns, functions and applications in the display.

2.2 Further information

In addition to this instruction manual of your BERNINA 740 following information products are enclosed:

- DVD with video instruction
- Accessory catalog

The latest version of your instruction manual as well as additional information in connection with sewing can be found on our website <http://www.bernina.com>

2.3 Key to signs

 **DANGER** Labels a danger with a high risk which can lead to death or severe injury unless it is avoided.

 **WARNING** Labels a danger with a medium risk which can lead to death or severe injury unless it is avoided.

 **CAUTION** Labels a danger with a low risk which can lead to light or medium injury unless it is avoided.

NOTICE Labels a danger which can end up with damage unless it is avoided.



Tips given by BERNINA **sewing experts** can be found next to this sign.

By means of illustration, sample pictures are used in this instruction manual. The machines as well as the accessory shown in the pictures may vary from the delivery content of your machine.

2.4 Overview

Overview front controls



- | | | | |
|---|----------------------|---|----------------------------|
| 1 | Quick reverse | 6 | Needle up/down |
| 2 | Thread cutter | 7 | Upper Multifunctional knob |
| 3 | Presser foot up/down | 8 | Lower Multifunctional knob |
| 4 | Start/Stop | 9 | Needle left/right |
| 5 | Pattern end | | |

Overview front



- | | | | |
|---|-----------------------------------------------|----|---------------------------------|
| 1 | Bobbin cover | 7 | Slide speed control |
| 2 | Connection for accessory (optional accessory) | 8 | Thread take-up lever cover |
| 3 | Presser foot | 9 | Thread take-up lever |
| 4 | Needle threader | 10 | Clamping screw |
| 5 | Sewing light | 11 | Connection for slide-on table |
| 6 | Thread guide | 12 | Connection for Free Hand System |

Overview sideways



- 1 Connection for foot control
- 2 PC-connection
- 3 Spool pin
- 4 Thread cutter
- 5 Spool holder to be swiveled
- 6 Handwheel

- 7 Power switch
- 8 Connection for power cable
- 9 Magnet holder for touchscreen pen
- 10 Air vents
- 11 USB port
- 12 Feed dog up/down

Overview back



- | | | | |
|---|-----------------------------------------------|----|----------------------|
| 1 | Connection for slide-on table | 9 | Thread pretension |
| 2 | Connection for darning hoop | 10 | Thread take-up lever |
| 3 | BSR connection | 11 | Thread guide |
| 4 | Connection for accessory (optional accessory) | 12 | Clamping screw |
| 5 | Air vents | 13 | BERNINA Dual Feed |
| 6 | Thread guide | 14 | Thread cutter |
| 7 | Bobbin winding unit | 15 | Feed dog |
| 8 | Carrying handle | 16 | Stitch plate |

2.5 Included accessories

Visit www.bernina.com for more accessory information.





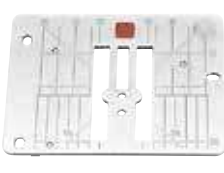















Illustration	Name	Purpose
	Soft Cover with pocket	The soft cover protects from dust and contamination.
	Accessory box	The accessory is stored in the accessory box.
	Presser foot lifter	The presser foot may be raised and lowered with the Free Hand System.
	Slide-on table	The slide-on table increases the sewing surface whereby the area of the free arm is not limited.
	Straight/Cutwork stitch plate	A small stitch hole in the area of the needle allows an optimized stitch entry. This results in a nicer stitch formation.
	3 Spool discs	Spool discs hold the thread spool in place for proper release of thread from the spool.
	3 Bobbins in the accessory, 1 bobbin in the bobbin case	The bobbins are filled with the lower thread.
	2 Foam pads	The foam pad prevents the thread from getting hooked at the spool holder.
	Touchscreen pen	The operation of the display is more precise when using the touchscreen pen instead of the fingers.
	Seam ripper	The seam ripper is an indispensable tool to undo stitches or to cut buttonholes open.

Illustration	Name	Purpose
	Height compensation tool	The height compensation tool levels an angled position of the presser foot sole when sliding over thick seams.
	Selection of needles	The needle assortment contains different versions and sizes of needles for all the common applications.
	Seam guide, right	The seam guide is very useful as a guideline on the right of the needle. It supports the alignment of regular seam distances.
	Screwdriver Torx, gray	Use the gray screwdriver Torx to change the needles.
	Screwdriver red	The red screwdriver is supplied as an all-round tool.
	Angular Torx button	The angular torx screwdriver is used to open the head frame.
	Brush	The brush is used to clean the feed dog and the hook area.
	Lubricator	The lubricator is used to fill up the oil depots.
	Power cable	The power cable connects the machine with the power supply system.
	Foot control	Via the foot control the machine is started and stopped. The speed of the machine is also controlled via the foot control.











Use of the power cable (USA/Canada only)

The machine has a polarized plug (one blade wider than the other). To reduce the risk of electrical shock, this plug is intended to fit in a polarized outlet only one way. If the plug does not fit fully in the outlet, reverse the plug. If it still does not fit, contact a qualified electrician to install the proper outlet. Do not modify the plug in any way!

Foot control (USA/Canada only)

Use only foot controller type LV-1 with BERNINA 740.

Presser feet

Illustration	Number	Name	Purpose	Example
	1C	Reverse pattern foot	Used to sew without dual feed.	
	1D	Reverse pattern foot	Used to sew with dual feed.	
	3A	Automatic Buttonhole foot with slide	Used to sew buttonholes.	
	4D	Zipper foot	Used with dual feed. For sewing in zippers.	
	20C	Open embroidery foot	Appliqués, decorative patterns.	

Accessory box

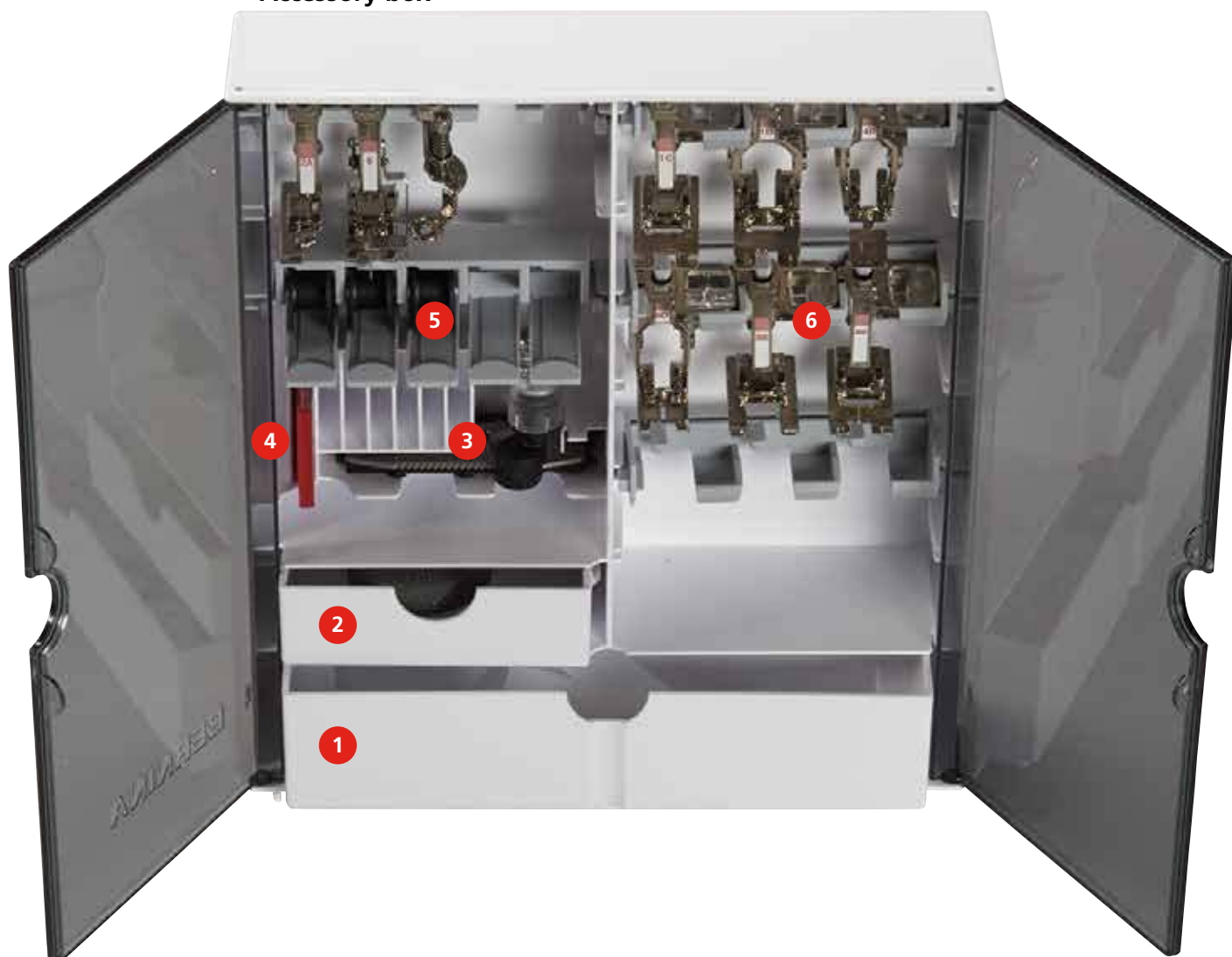

- | | | | |
|---|--------------------------------------|---|----------------------|
| 1 | Big drawer | 4 | Selection of needles |
| 2 | Small drawer | 5 | Bobbins |
| 3 | Automatic Buttonhole foot with slide | 6 | Presser feet |

2.6 Overview Selection Menu on the left (External Functions/Views)



- | | | | |
|---|-----------------------|---|--------------------------------|
| 1 | Upper thread tension | 4 | Stitch plate/Needle selection |
| 2 | Presser foot display | 5 | Feed dog up/down |
| 3 | Presser foot pressure | 6 | Filling level of bobbin thread |



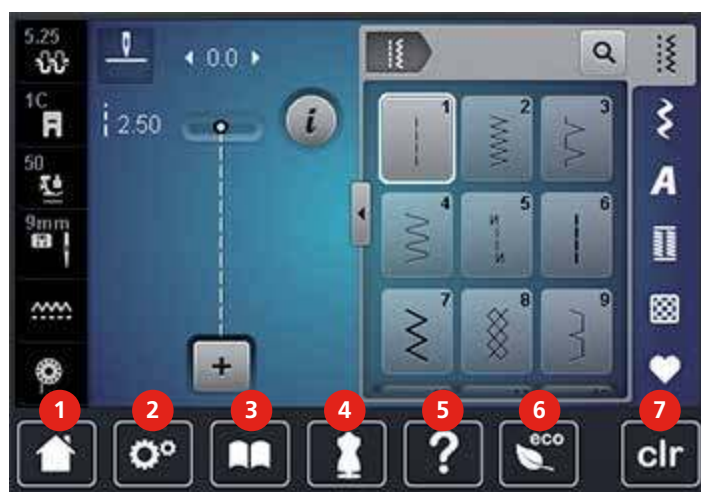





2.7 Overview Selection Menu below (System settings)

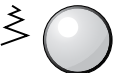

- | | | | |
|---|---------------------|---|-----------------------|
| 1 | Home | 5 | Help |
| 2 | Setup Program | 6 | eco mode |
| 3 | Tutorial | 7 | Back to basic setting |
| 4 | Creative Consultant | | |

2.8 Buttons and icons

Icon	Name	Purpose
	Close	The screen is closed and the previously made adjustments are saved.

Icon	Name	Purpose
	Confirm	Confirms any adjusted settings. The screen is closed.
	Cancel	The process is canceled. The screen is closed and the previously made adjustments are not saved.
 	Touch the icons «-/+»	Via the icons «-» and «+» setting values can be changed.
 	«Upper Multifunctional knob» and «Lower Multifunctional knob»	Via the «Upper Multifunctional knob» and the «Lower Multifunctional knob» setting values can be changed.
	Slide	By moving the slide the setting values are changed.
	Switch	Activates or deactivates functions.
	Process navigation	With the process navigation scrolling back in the display is possible.
	Wiping function	By wiping up or down on the display with the touchscreen pen or the finger further functions can be displayed.

2.9 Needle, Thread, Fabric

In the course of time a needle wears out. Therefore it should be replaced regularly. Only a perfect point results in a good stitching result. In general it can be said: the thinner the thread, the finer the needle. The illustrated needles are either standard or optional accessory, depending on the machine.

- Sizes 70, 75: for thin fabrics.
- Sizes 80, 90: for medium fabrics.
- Sizes 100, 110 and 120: for heavy fabrics.

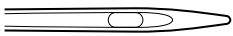
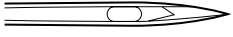
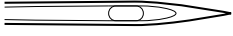



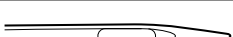



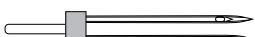

Illustration	Needle name	Needle description	Purpose
	Universal 130/705 H/60-100	Average point, slightly rounded	For nearly all natural and synthetic fabrics (woven and knitted).

Illustration	Needle name	Needle description	Purpose
	Jersey/Stretch 130/705 H-S, H-SES, H-SUK/70-90	Ball point	Jersey, tricot, knit and stretch fabrics.
	Leather 130/705 H-LL, H-LR/90-100	With cutting point	All types of leather, synthetic leather, plastic, sheeting.
	Jeans 130/705 H-J/80-110	Very fine point	Heavy weight fabrics such as jeans, canvas.
	Microtex 130/705 H-M/60-90	Especially fine point	Micro fiber fabrics and silk.
	Quilting 130/705 H-Q/75-90	Fine point	Straight and topstitching.
	Embroidery 130/705 H-SUK/70-90	Large eye, slight ball point	Embroidery on all natural and synthetic fabrics.
	Metafil 130/705 H-MET/75-80 or H-SUK/90-100	Large eye	Sewing projects with metallic threads.
	Cordonnet (Topstitching) 130/705 H-N/80-100	Small ball point, long eye	Topstitching with thick thread.
	Wing needle (Hemstitch needle) 130/705 HO/100-120	Wide needle (wing)	Hemstitching.
	Double wing needle 130/705 H-ZWI-HO/100		For special effects with hemstitch embroidery.
	Double needle 130/705 H-ZWI/70-100	Needle distance: 1.0/1.6/2.0/2.5/ 3.0/4.0/6.0/8.0	Visible hems in stretch fabrics: pintucks, decorative sewing.
	Triple needle 130/705 H-DRI/80	Needle distance: 3.0	Visible hems in stretch fabrics, pintucks, decorative sewing.

Thread selection

For a perfect sewing result, thread and fabric quality play an important role.

We recommend purchasing quality threads to achieve good sewing results.

- Cotton threads have the advantage of being a natural fiber and therefore are especially suitable for sewing cotton fabrics.
- Mercerized cotton threads have a slight sheen that is not lost with washing.
- Polyester threads have a high tensile strength and is particularly colorfast.
- Polyester threads are more flexible and are recommended where a strong and elastic seam is required.
- Rayon threads are made of natural fibers and have a brilliant sheen.
- Rayon threads are suitable for decorative stitches and achieve a more beautiful effect.

Example for needle description

The 130/705 system, which is the most common for household machines, is explained by the following picture of a Jersey/Stretch needle.

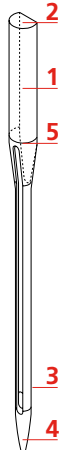
	<p>130/705 H-S/70</p> <p>130 = Shank length (1)</p> <p>705 = Flat shank (2)</p> <p>H = Needle scarf (3)</p> <p>S = Needle point (here medium ball point) (4)</p> <p>70 = Needle size (shank diameter) (5)</p>
------------------------------------------------------------------------------------	---------------------------------------------------------------------------------------------------------------------------------------------------------------------------------------------------------------------------------------------------------

Needle/thread combination

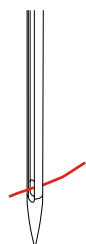
	<p>The needle/thread combination is correct, when the thread fits perfectly into the long groove and goes easily through the needle eye. The thread can be optimally sewn.</p>
	<p>The thread can break and skipped stitches can occur when there is too much clearance in the long groove and the needle eye.</p>

3 Preparation

3.1 Accessory box

Accessory box free standing

- > On the back of the box, pull both extensions out until they click into place.



Storing accessories

NOTICE Incorrect sorting of the bobbin

The silvery sensor surface can get scratched.

- > Make sure that the silvery sensor surfaces are on the right side when sorting the bobbins into the accessory box.

- > Store small parts in the drawers (1) and (2).
- > Store the Buttonhole foot with slide No. 3A in compartment (3).
- > Store the provided needle package in the special compartment (4).
- > Insert the bobbins into the compartment (5) of the accessory box so that the silvery sensor surfaces are on the right side.
- > To remove a bobbin, press the compartment holder down.
- > Store the presser feet in the compartment (6).



3.2 Connection and Switching on

Connecting the foot control

- > Unwind the cable of the foot control to the desired length.



- > Insert the cable of the foot control into the connection (1).



Connecting the machine

- > Insert the power cable into the connection (1).



- > Insert the plug of the power cable into the electrical outlet.

Attaching the lever of the Free Hand System



The lateral position of the lever can be adjusted by your local BERNINA Dealer required.

- > Insert the FHS lever into the opening at the front side of the machine.



Fixing the touchscreen pen

- > Store the touchscreen pen at the magnet holder (1).



Switching the machine on

- > Switch the main power switch to (1) «I».



3.3 Foot control

Sewing speed control

With the foot control the sewing speed can be adjusted steplessly.

- > Press the foot control down carefully to start the machine.
- > To sew faster, press the foot control harder.

- > Release the foot control to stop the machine.



Raising/Lowering the needle

- > Sink the heel back on the foot control to raise/lower the needle.



3.4 Spool holder

Installing the spool holder



With metallic or other special threads, it is recommend to use the swiveling spool holder and the eyelet for metallic and silk thread (optional accessory).

The swiveling spool holder is necessary when several threads are sewn and it can also be used for bobbin winding while sewing.

- > Swivel the spool holder up as far as it will go.



Inserting foam pads

The foam pad prevents the thread from getting hooked at the swiveling spool holder.

- > Place the foam pad on the swiveling spool holder.



Positioning the spool disc

Spool discs hold the thread spool in place for proper release of thread from the spool.

- > Place the foam pad on the spool holder.
- > Place the thread spool on the spool pin.
- > Position the appropriate spool disc on the spool pin so that there is no space between the spool disc and the thread spool.



Using a spool net

The spool net provides an even unwinding of the thread from the thread spool and prevents the thread from knotting and breaking.

- > Place the thread spool on the spool holder.
- > Pull the spool net over the thread spool.



3.5 Free arm

Adjusting the feed dog

NOTICE Inappropriate handling of the fabric

Damage of the needle and the stitch plate.

- > Let the sewing project be fed evenly.

With each stitch, the feed dog moves forward by one step. The length of this step is determined by the stitch length selected.

With a short stitch length, the steps are very short. For example when sewing buttonholes and satin stitches. The fabric is fed slowly under the presser foot, even when sewing at maximal speed.

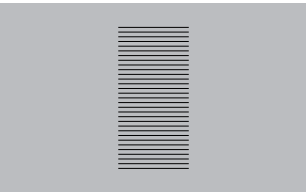
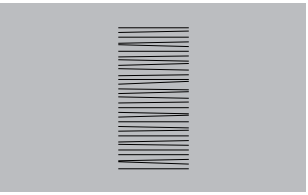
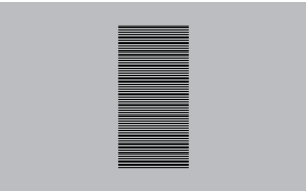
	Let the fabric be fed evenly; this results in a more perfect stitch formation.
	Pulling or pushing the fabric will result in uneven stitches.
	Holding back the fabric will result in uneven stitches.

- > Push the button «Feed dog up/down» (1) to lower the feed dog.



- > Push the button again to sew with the feed dog up.

Using the slide-on table

- > Raise the needle.
- > Raise the presser foot.
- > Switch the machine off and disconnect it from the power supply system.

- > Push the slide-on table to the right until it engages.



- > To remove the slide-on table, push the button down and pull the slide-on table to the left.



3.6 Presser foot

Adjusting the presser position via the lever of the Free Hand System

- > Adjust the sitting height so that the lever can be operated with the knee.
- > Move the lever with the knee to the right to raise the presser foot.

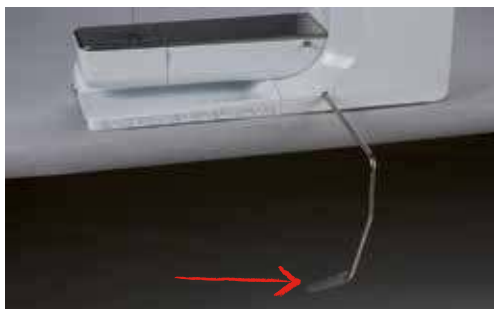

- Simultaneously the feed dog is lowered and the thread tension is released.
- > Release the lever slowly to lower the presser foot.

Adjusting the presser foot position via the button Presser foot up/down

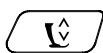

- > Press the button «Presser foot up/down» to raise the presser foot.
- > Press the button «Presser foot up/down» again to lower the presser foot.

Changing the presser foot

- > Raise the needle.
- > Raise the presser foot.
- > Switch the machine off and disconnect it from the power supply system.

- > Push the clamping lever up.



- > Remove the presser foot.
- > Guide the new presser foot upwards over the cone.
- > Press the clamping lever down.

Displaying the presser foot

After the presser foot has been changed, it can be checked whether or not the presser foot is suitable for the selected stitch pattern. In addition to that, alternative presser feet are displayed which are available for the currently selected stitch pattern.

- > Switch the machine on.
- > Select a stitch pattern.
- > Touch the icon «Presser foot display».
- > Using the touchscreen pen or the finger, wipe up in the area of the presser feet to display alternative presser feet.



- When the attached presser foot is suitable, sewing can be started.

Adjusting the presser foot pressure



With thick fabrics it is recommended to reduce the presser foot pressure. The advantage is that the presser foot is slightly lifted so that the fabric can be moved more easily.



- > Touch the icon «Presser foot pressure».
- > Move the slide with the touchscreen pen or the finger to adjust the presser foot pressure.
- > Touch the yellow-framed icon to reset the alterations to basic setting.

3.7 Adjusting the feed dog



- > Touch the icon «Feed dog up/down» to raise or lower the feed dog according to the animation.

3.8 Checking the filling level of the bobbin thread

The remaining bobbin thread is indicated on the display.



- > Touch the icon «Filling level of bobbin thread» .
- > Thread the bobbin thread according to the animation.

3.9 Needle and stitch plate

Adjusting the needle position up/down



- > Press the button «Needle up/down» to lower the needle.
- > Press the button «Needle up/down» again to raise the needle.

Adjusting the needle position left/right

There is a total of 11 needle positions. The needle position is indicated by the needle position number in the display.

- > Press the button «Needle left» (1) to move the needle to the left.
- > Press the button «Needle right» (2) to move the needle to the right.



Needle stop up/down (permanent)



- > Touch the icon «Needle stop up/down (permanent)» to fix the needle position permanently.
 - The machine stops with needle position down as soon as the foot control is released or the button «Start/Stop» has been pressed.
- > Touch the icon «Needle stop up/down (permanent)» again.
 - The machine stops with needle position up as soon as the foot control is released or the button «Start/Stop» has been pressed.

Changing the needle

- > Raise the needle.
- > Switch the machine off and disconnect it from the power supply system.
- > Remove the presser foot.
- > Loosen the needle clamp screw using the screwdriver grey Torx.



- > Pull the needle down.
- > Hold the new needle with the flat side to the back.
- > Insert the needle as far as it will go.
- > Tighten the needle clamp using the screwdriver grey Torx.

Selecting the needle

After having changed the needle, it can be checked whether or not it can be used in combination with the selected stitch plate.



- > Touch the icon «Stitch plate/Needle selection».



- > Selected the inserted needle.

Select the needle type and the needle size

Convenient memory function: To prevent a loss of information, the needle type and the needle size can be saved additionally on the machine. The saved needle type and the saved needle size can be checked at any time.



- > Touch the icon «Stitch plate/Needle selection».



- > Touch the icon «Needle type/Needle size».
- > Select the needle type (1) of the inserted needle.
- > Select the needle size (2) of the inserted needle.



Changing the stitch plate

The stitch plate is marked with vertical, horizontal and diagonal lines in millimeters (mm) and inches (inch). These lines help to guide the fabric when sewing seams and precise topstitching.

- > Lower the feed dog.
- > Switch the machine off and disconnect it from the power supply system.
- > Remove the needle.
- > Remove the presser foot.
- > Press the stitch plate down at the mark back right until it flips up.



- > Remove the stitch plate.
- > Place the openings of the new stitch plate above the corresponding guide pins and press down until it clicks into place.

Selecting the stitch plate

After having changed the stitch plate, it can be checked whether or not it can be used in combination with the selected needle.



- > Touch the icon «Stitch plate/Needle selection».

- > Select the previously attached stitch plate.



- When the selected stitch plate is suitable in combination with the needle, sewing can be started.
- When the selected stitch plate is not suitable in combination with the needle, the machine prevents starting automatically.

3.10 Threading

Threading preparation

- > Raise the needle.
- > Raise the presser foot.
- > Switch the machine off and disconnect it from the power supply system.

Threading the upper thread

- > Place the foam pad on the spool holder.
- > Place the thread spool on the pin so that the thread is unwound clockwise.
- > Add the appropriate thread disc.
- > Guide the thread in direction of the arrow into the rear thread guide and hold the thread with the hands so that it is taut and can be inserted into the thread pretension.
- > Guide the thread in direction of the arrow through the tread pretension.



- > Pull the thread in direction of the arrow down (1) around the cover of the thread take-up lever (2).
- > Guide the thread in direction of the arrow up (3) and insert it into the thread take-up lever.

> Pull the thread in direction of the arrow down (4).



> Guide the thread through the guides above the presser foot.



> Switch the machine on.

- > Press the lever down, keep pressed and pull the thread to the left.



- > Guide the thread around the grey hook from the left to the right.
- > Pull the thread through the thread guide until it engages in the wire hook.

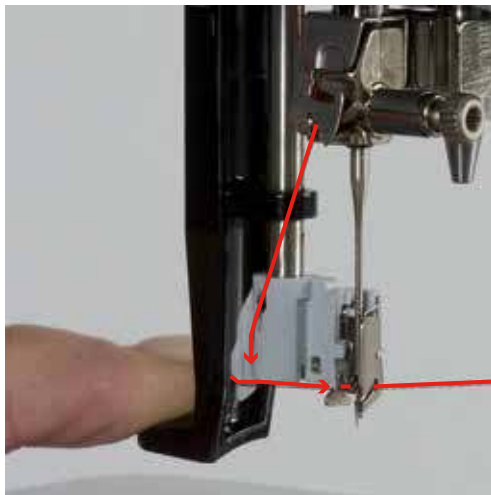

- > Release the lever and the thread simultaneously to thread the needle.
- > Pull the thread loop to the back.

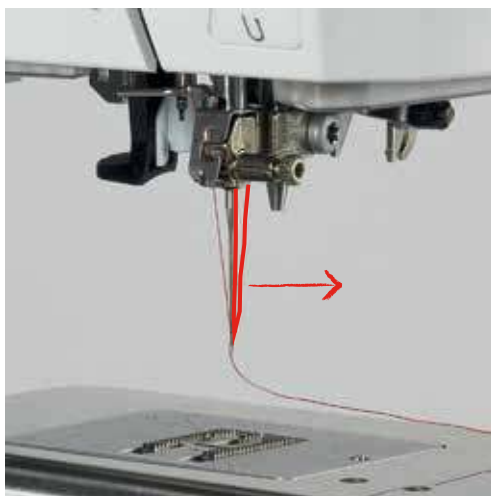

- > Pull the thread under the presser foot and pull it over the thread cutter from back to front to cut.



Threading the double needle

Prerequisite:

- The double needle is inserted.
- > Guide the first thread in direction of the arrow on the right side of the tension disc (1).
- > Guide the second thread in direction of the arrow on the left side of the tension disc (1).

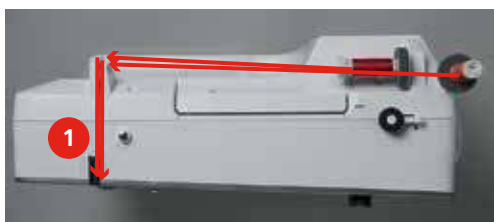

- > Guide the first and the second thread to the thread guide above the needle (see page 39).
- > Thread the first thread manually into the right needle.
- > Thread the second thread manually into the left needle.

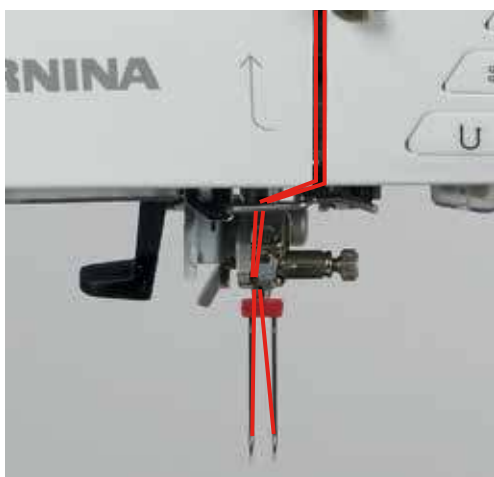

Threading the triple needle

Always attach a foam pad when using the swiveling spool holder. This prevents the thread from getting hooked at the spool holder.

Prerequisite:

- The triple needle is inserted.
- > Place the foam pad, the thread spool and the appropriate thread disc on the spool holder.
- > Place the filled bobbin on the swiveling spool holder.
- > Add the appropriate thread disc.
- > Place the thread spool.
- > Thread the 3 threads up to the upper thread guide.

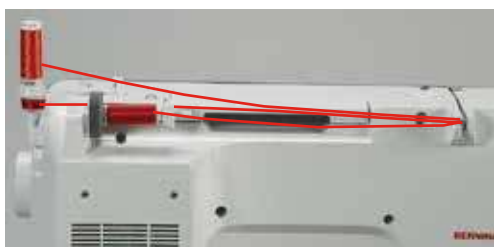

- > Guide 2 threads past the thread tension discs on the left and to the thread guide above the needle (see page 39).
- > Guide 1 thread past the thread tension disc on the right and to the thread guide above the needle (see page 39).
- > Thread the first thread into the left needle manually.
- > Thread the second thread into the center needle manually.
- > Thread the third thread into the right needle manually (see page 42).

Winding the bobbin thread



The bobbin thread can be wound while sewing if the swiveling spool holder is used for winding.

- > Place a foam pad on the spool holder.
- > Place the thread spool on the spool holder.
- > Add the appropriate thread disc on the spool holder.
- > Attach the empty bobbin on the winding unit (1) so that the silvery sensor surface is down.



- > Guide the thread in direction of the arrow into the rear thread guide (1).
- > Guide the thread around the thread pretension clockwise (2).

- > Wind the thread clockwise two to three times around the empty bobbin (3).

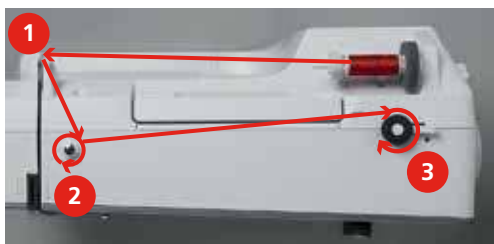

- > Pull the excess thread over the thread cutter at the engaging lever and cut.



- > Push the engaging lever towards the bobbin.



- The machine winds and the display to wind the bobbin appears.
- > Move the slide on the display using the touchscreen pen or the finger to adjust the winding speed.
- > Push the engaging lever to the right to stop the winding process.
- > Push the engaging lever towards the bobbin again to continue the winding process.
 - As soon as the bobbin is full, the machine stops the winding process automatically.
- > Remove the bobbin and cut the thread using the thread cutter at the engaging lever.

Threading the bobbin thread

- > Raise the needle.
- > Switch the machine off.
- > Open the bobbin cover.

- > Press the bobbin case release at the bobbin case (1).



- > Remove the bobbin case.
- > Remove the bobbin from the bobbin case.
- > Insert the new bobbin so that the silvery sensor surface is to the back.



- > Pull the thread into the slot from the left.



- > Pull the thread to the right under the spring (1), then lead the thread under the thread guide and pull upwards.



- > Hold the bobbin case so that the thread guide points upward.



- > Insert the bobbin case.
- > Press onto the center of the bobbin case until it engages.
- > Pull the thread through the thread cutter and cut.



- > Close the bobbin cover.

3.11 Calling up the Tutorial

The tutorial provides information and explanations on different sections concerning sewing and the various stitches.



- > Touch the icon «Tutorial».
- > Select the desired topic to get information.

3.12 Calling up the Help



- > Touch the window in the display where help is needed.
- > Touch the icon «Hilfe» to start the help mode.
- > Touch the icon in the display where help is needed.
 - Assistance concerning the selected icon is displayed.

3.13 Calling up the Creative Consultant

The Creative Consultant provides information about decision support concerning sewing projects. After entering the fabric and the desired sewing project, suggestions for suitable needles, presser feet etc. are displayed.



- > Touch the icon «Creative Consultant».
- > Select the fabric to be sewn.
- > Select the sewing project.

4 Setup-Program

4.1 Sewing settings

Adjusting the upper thread tension

Alterations of the upper thread tension in the Setup Program affect all stitch patterns. Individual alteration of the upper thread tension can also be made for currently selected stitches.



- > Touch the icon «Setup Program».



- > Touch the icon «Sewing settings».



- > Touch the icon «Adjusting the upper thread tension».
- > Move the slide using the touchscreen pen or the finger to adjust the upper thread tension.
- > Touch the yellow-framed icon to reset the alteration to basic setting.

Adjusting the maximum sewing speed



- > Touch the icon «Setup Program».



- > Touch the icon «Sewing settings».



- > Touch the icon «Adjusting maximum sewing speed».
- > Move the slide using the touchscreen pen or the finger to adjust the maximum sewing speed.
- > Touch the yellow-framed icon to reset the alteration to basic setting.

Programming the securing stitches

If the function is activated, 4 securing stitches are sewn automatically at the pattern start after the thread cut.



- > Touch the icon «Setup Program».



- > Touch the icon «Sewing settings».





- > Touch the switch using the touchscreen pen or the finger to deactivate the securing stitches.
- > Touch the switch again to activate the securing stitches.







Adjusting the hovering height of the presser foot



- > Touch the icon «Setup Program».

-  > Touch the icon «Sewing settings».
-  > Touch the icon «Programming buttons and icons».
-  > Touch the icon «Programming hovering height of the presser foot».
- > Turn the «Upper Multifunctional knob» or the «Lower Multifunctional knob» or touch the icons «-» and «+» to determine the distance between the fabric and the presser foot.
- > Touch the yellow-framed icon to reset the alteration to basic setting.

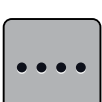
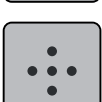
Programming the button «Pattern end»

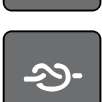
-  > Touch the icon «Setup Program» .
-  > Touch the icon «Sewing settings».
-  > Touch the icon «Programming buttons and icons».
-  > Touch the icon «Programming the button Pattern end».
-  > Touch the icon «Securing» to sew 4 securing stitches in place.
-  > Touch the icon «Altering the number of securing stitches» to program sequenced securing stitches.
- > Touch the icons «-» and «+» to program the number of the sequenced securing stitches.
- > Touch the yellow-framed icon to reset the alteration to basic setting.
-  > Touch the icon «Securing stitches in place» to program 4 securing stitches in place.
-  > Touch the icon «Thread cut» to deactivate the automatic thread cut after securing.
- > Touch the icon «Thread cut» again to activate the automatic thread cut after securing.
-  > Touch the icon «Positioning the presser foot» to raise the presser foot after securing.
- > Touch the icon «Positioning the presser foot» again to raise the presser foot after securing.
-  > Touch the icon «Securing» to deactivate the automatic securing.
- > Touch the icon «Securing» again to activate the automatic securing.

Programming the button «Thread cutter»

-  > Touch the icon «Setup Program».



> Touch the icon «Sewing settings».



> Touch the icon «Programming buttons and icons».



> Touch the icon «Programming the button Thread cutter».



> Touch the icon «Securing» to sew 4 securing stitches in place.

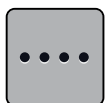

> Touch the icon «Changing the number of securing stitches» to enter the number of the sequenced securing stitches.

> Touch the icons «-» and «+» to enter the number of the sequenced securing stitches.

> Touch the yellow-framed icon to reset the alteration to basic setting.

> Touch the icon «Securing stitches in place» to program 4 securing stitches in place.

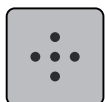

> Touch the icon «Securing» to deactivate the automatic securing.

> Touch the icon «Securing» again to activate the automatic securing.

Adjusting the presser foot position with needle stop down

With lowered needle, 3 different presser foot position can be selected: the presser foot lowered, the presser foot is raised to hovering position and the presser foot is raised to its maximum height.



> Touch the icon «Setup Program».



> Touch the icon «Sewing settings».



> Touch the icon «Programming buttons and icons».



> Touch the icon «Adjusting the presser foot position with needle stop down».



> Select the desired presser foot position.

Programming the button «Quick reverse»



> Touch the icon «Setup Program».



> Touch the icon «Sewing settings».



> Touch the icon «Programming buttons and icons».



> Touch the icon «Programming the button Quick reverse».



> Touch the icon «Backstepping» to activate the backstepping.

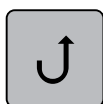

> Touch the icon «Quick reverse permanent» to activate the permanent reverse sewing.

4.2 Selecting personal settings



> Touch the icon «Setup Program».



- > Touch the icon «Personal settings».
- > Select the desired color of the display and the background.
- > Touch the text box above the color settings.



- > Enter the welcome text.
- > Touch the icon «ABC» (standard setting) to use upper-case letters.
- > Touch the icon «abc» to use lower-case letters.
- > Touch the icon «123» to use figures and mathematical symbols.
- > Touch the icon «@&!» to use special characters.
- > Touch the text box above the keyboard to delete the entered text completely.
- > Touch the icon «DEL» to delete individual syllables of the entered text.



> Touch the icon «Confirm».

4.3 Monitoring functions

Activating the upper thread indicator



> Touch the icon «Setup Program».



> Touch the icon «Monitoring settings».



- > Touch the switch in the upper portion of the display to deactivate the upper thread indicator.
- > Touch the switch again to activate the upper thread indicator.

4.4 Activating the audio signals



> Touch the icon «Setup Program».



- > Touch the icon «Audio signals».
- > Touch the switch (1) to deactivate any audio signals in general.
- > Touch the switch (1) again to activate any audio signals in general.
- > In the section (2) touch the icons «1 – 4» to set up the desired signal for the selection of a stitch pattern.



- > In the section (2) touch the icon «Loudspeaker» to deactivate the signal for the selection of a stitch pattern.
- > In the section (2) touch the icon «Loudspeaker» again to activate the signal for the selection of a stitch pattern.



- > In the section (3) touch the icons «1 – 4» to activate the signal for the selection of functions.
- > In the section (3) touch the icon «Loudspeaker» to deactivate the signal for the selection of functions.
- > In the section (3) touch the icon «Loudspeaker» again to activate the signal for the selection of functions.



- > In the section (4) touch the icon «Loudspeaker» to deactivate the signal when using the BSR modes.
- > In the section (4) touch the icon «Loudspeaker» again to activate the signal when using the BSR modes.



4.5 Machine settings

Selecting a language



> Touch the icon «Setup Program».



> Touch the icon «Machine settings».



- > Touch the icon «Language selection».
- > Select a language.

Adjusting the brightness of the display



- > Touch the icon «Setup Program».



- > Touch the icon «Machine settings».



- > Touch the icon «Display settings».
- > Move the slide in the upper portion of the display using the touchscreen pen or the finger to alter the brightness of the display.
- > Touch the yellow-framed icon to reset the alteration to basic setting.

Adjusting the sewing light



- > Touch the icon «Setup Program».



- > Touch the icon «Machine settings».



- > Touch the icon «Display settings».
- > Move the slide in the lower portion of the display using the touchscreen pen or the finger to alter the brightness of the sewing light.
- > Touch the yellow-framed icon to reset the alteration to basic setting.



- > Touch the switch to switch the sewing light off.
- > Touch the switch again to switch the sewing light on.

Calibrating the display



- > Touch the icon «Setup Program».



- > Touch the icon «Machine settings».



- > Touch the icon «Calibrating the display».

> Touch the crosses in sequence using the touchscreen pen.

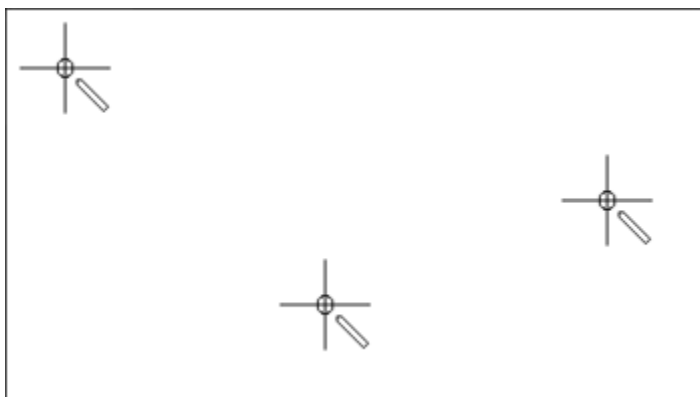

Back to basic settings



> Touch the icon «Setup Program».



> Touch the icon «Machine settings».



> Touch the icon «Basic setting».



> Touch the icon «Basic settings sewing».



> Touch the icon «Confirm» to restore the basic settings for the sewing settings.



> Touch the icon «Basic setting all».



> Touch the icon «Confirm» to restore all basic settings.

Deleting user data



> Touch the icon «Setup Program».



> Touch the icon «Machine settings».



> Touch the icon «Basic settings».



> Touch the icon «Deleting data from personal memory».



> Touch the icon «Confirm» delete all data from the personal memory.

Deleting data from the BERNINA USB Stick (optional accessory)

If saved data on the BERNINA USB Stick (optional accessory) is not needed anymore, the stick can be connected to the machine and the data can be deleted.

- > Insert the BERNINA USB Stick (optional accessory) into the port (1).



- > Touch the icon «Setup Program».



- > Touch the icon «Machine settings».



- > Touch the icon «Basic settings».



- > Touch the icon «Deleting data from USB Stick».



- > Touch the icon «Confirm» to delete all data on the BERNINA USB Stick (optional accessory).

Calibrating the Buttonhole foot No. 3A

The Buttonhole foot No. 3A is calibrated to this machine and should only be used both together.

Prerequisite:

- The Buttonhole foot No. 3A is attached.
- The needle is not threaded.



- > Touch the icon «Setup Program».



- > Touch the icon «Machine settings».



- > Touch the icon «Maintenance/Update».



- > Touch the icon «Buttonhole foot No. 3A».

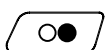

- > Touch the button «Start/Stop» to start the calibration.

Updating the software

NOTICE BERNINA USB stick (optional accessory) has been removed too early

The software has not been updated and the machine cannot be used.

- > Remove the BERNINA USB stick (optional accessory) only after the update has been completed successfully.

The latest software and a detailed step by step instruction can be downloaded at www.bernina.com. In general, personal data and settings are automatically transferred during a software update. For reasons of safety, it is recommended to save data and settings on a BERNINA USB stick (optional accessory) before the software update is started. If personal data and settings should get lost during an update, they can be transferred to the machine again afterwards.

- > Insert the BERNINA USB Stick (optional accessory), FAT32 formatted, providing the latest software into the port(1).



- > Touch the icon «Setup Program».



- > Touch the icon «Machine settings».



- > Touch the icon «Maintenance/Update».



- > Touch the icon «Updating the machine».



- > Touch the icon «Saving data on USB stick».



- > Touch the icon «Update» to start the update of the software.

Recovering saved data

NOTICE BERNINA USB stick (optional accessory) has been removed too early

Saved data cannot be transferred and the machine cannot be used.

- > Remove the BERNINA USB stick (optional accessory) only after the saved data has been transferred successfully.

If personal data and settings after a software update are not available anymore, they can be transferred to the machine again afterwards.

- > Insert the BERNINA USB stick (optional accessory) with the latest software into the USB port (1).



- > Touch the icon «Setup Program».



- > Touch the icon «Machine settings».



- > Touch the icon «Maintenance/Update».



- > Touch the icon «Updating the machine».



- > Touch the icon «Transferring saved data to machine».

Cleaning the machine

The Setup Program provides animations how to clean the machine. In chapter «Maintenance and Cleaning», there are more illustrated step by step instructions (see page 115).



- > Touch the icon «Setup Program».



- > Touch the icon «Machine settings».



- > Touch the icon «Maintenance/Update».



- > Touch the icon «Cleaning the machine».
- > Clean the machine according to the instructions on the display.

Lubricating the machine

The Setup Program provides animations how to oil the machine. In chapter «Maintenance and Cleaning»; there are more illustrated step by step instructions (see page 115). Use BERNINA oil to lubricate.



- > Touch the icon «Setup Program».



> Touch the icon «Machine settings».



> Touch the icon «Maintenance/Update».



> Touch the icon «Lubricating the machine».
> Lubricate the machine according to the instructions on the display.

Checking the Software Version



> Touch the icon «Setup Program».



> Touch the icon «Machine settings».



> Touch the icon «Information».



> Touch the icon «Version».

Reviewing the total number of stitches



> Touch the icon «Setup Program».



> Touch the icon «Machine settings».



> Touch the icon «Information».



> Touch the icon «Version».

Registering details of the dealer



> Touch the icon «Setup Program».



> Touch the icon «Machine settings».



> Touch the icon «Information».



> Touch the icon «Dealer details» to enter the information of the specialized dealer.



> Touch the icon «Name of the shop» to enter the name of the specialized BERNINA dealer.



> Touch the icon «Address» to enter the address of the specialized BERNINA dealer.



> Touch the icon «Phone» to enter the telephone number of the specialized BERNINA dealer.



> Touch the icon «Internet» to enter the Internet homepage or the email address of the specialized BERNINA dealer.

Saving Service data

Service data concerning the status quo of the machine can be saved on a BERNINA USB stick (optional accessory) and then given to the BERNINA dealer this way.

> Insert a BERNINA USB stick (optional accessory) which provides enough free memory space into the USB port (1).



> Touch the icon «Setup Program».



> Touch the icon «Machine settings».



> Touch the icon «Information».



> Touch the icon «Service data».

> Touch the icon «LOG».

– The icon «LOG» is outlined in white.

> Only when the icon is not outlined in white anymore, remove the BERNINA USB Stick (optional accessory).

5 Creative sewing

5.1 Overview Sewing functions



- | | | | |
|---|---------------------|---|-----------------|
| 1 | Practical stitches | 4 | Buttonholes |
| 2 | Decorative stitches | 5 | Quilt stitches |
| 3 | Alphabets | 6 | Personal Memory |

Selecting a stitch pattern

- > Select stitch pattern, alphabet or a buttonhole.
- > Wipe up in the area of the practical stitches to have more stitch patterns displayed.
- > Touch the icon «Display all stitch patterns» (1) to scale up the view.



- > Touch the icon «Display all stitch patterns» (1) again to to downsize the stitch pattern view.
- > Touch the icon «Stitch pattern selection by number» to select the stitch pattern by entering the stitch number.



5.2 BERNINA Dual Feed



It is recommended to match the presser foot pressure with the fabric. The thicker the fabric, the lower the presser foot pressure.

The BERNINA Dual Feed feeds the fabric from above and from beneath simultaneously. This provides an even and careful feed forward even for smooth and thin materials. Striped and checkered patterns can be matched perfectly by even feeding.

In general, the BERNINA Dual Feed is used for the following sewing projects:

- Sewing: All sewing applications with difficult fabrics such as for seams, zippers.
- Patchwork: With accurate stripes, blocks and with decorative stitches up to a stitch width of 9 mm.
- Appliqués: sewing appliques, ribbons and bias binding.

Difficult-to-work-with fabrics are:

- Velvet, normally sewn with the grain.
- Toweling.
- Jersey, especially when sewing it crosswise to knit.
- Fake fur or coated fake fur.
- Fleece-types of fabrics.
- Batted fabrics.
- Stripes and checks.
- Curtain fabrics with pattern repeats.

«Sticky» fabrics are:

- Imitation leather, coated fabrics (Dual Feed presser foot with sliding sole).

Application of the BERNINA Dual Feed



Only use presser feet with a cut-out at the center back and the labeling «D». Additional presser feet with the labeling «D» are listed in the enclosed accessory catalog.

- > Raise the presser foot.
- > Attach the presser foot with the labeling «D».
- > Pull the dual feed down until it engages.



- > Raise the presser foot.

- > Hold the dual feed on the holder with two fingers, pull it down, then push backward, slowly letting it slide upward.



5.3 Sewing speed control

The sewing speed is infinitely variable with the slide.

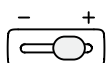

- > Move the slide to the left to reduce the sewing speed.
- > Move the slide to the right to increase the sewing speed.

5.4 Editing stitch patterns

Changing the stitch width

- > Turn the «Upper Multifunctional knob» to the left to narrow the stitch width.
- > Turn the «Upper Multifunctional knob» to the right to widen the stitch width.
- > Touch the icon «Stitch width» (1).



- > Touch the yellow-framed icon to reset the alteration to basic setting.

Changing the stitch length

- > Turn the «Lower Multifunctional knob» to the left to shorten the stitch length.
- > Turn the «Lower Multifunctional knob» to the right to elongate the stitch length.
- > Touch the icon «Stitch length» (1).



- > Touch the yellow-framed icon to reset the alteration to basic setting.

Adjusting the upper thread tension

The basic setting of the upper thread tension is provided automatically as soon as a stitch pattern is selected.

The upper thread tension is set optimally at the BERNINA factory and the sewing computer has been tested. Metrosene-/Seralon thread size 100/2 (Company Mettler, Switzerland) is used for upper and bobbin thread.

In case of using other types of sewing threads, the optimal tension may vary. Therefore it may be necessary to adjust the upper thread tension according to the sewing project as well as the desired stitch pattern individually.

The higher the upper thread tension, the tighter the upper thread which means that the bobbin thread is pulled up to the top of the fabric. When the upper thread tension is low, the upper thread is less tightened which means that the bobbin thread is pulled up less.

Alteration of the upper thread tension affect the currently selected stitch pattern. Permanent alterations of the upper thread tension for the sewing mode can be made in the Setup Program.



- > Touch the icon «Upper thread tension».
- > Move the slide using the touchscreen pen or the finger to increase or reduce the upper thread tension.



- > Touch the yellow-framed icon to reset the alteration to basic setting.

Correcting the balance

The machine is tested and set optimally before it leaves the BERNINA factory. Different fabrics, threads and stabilizers can affect the programmed stitch patterns so that they cannot be sewn out correctly. The electronic balance can correct these deviation and the stitch pattern can be adjusted optimally to the selected fabric.

- > Select a stitch pattern or alphabet.
- > Touch the icon «i»-Dialog.



- > Touch the icon «Balance».
- > Turn the «Lower Multifunctional knob» to correct the horizontal direction of the stitch pattern.

Programming pattern repeat

- > Select a stitch pattern or alphabet.
- > Touch the icon «i»-Dialog.



- > Touch the icon «Pattern repeat» once to repeat the stitch pattern.
- > Touch the icon «Pattern repeat» again to repeat the stitch pattern up to 9 times.
- > Keep the icon «Pattern repeat» touched to deactivate the stitch pattern repeat.

Mirror image of stitch patterns

- > Select a stitch pattern or alphabet.
- > Touch the icon «i»-Dialog.



- > Touch the icon «Mirror image left/right» to mirror the stitch pattern from left to right.



- > Touch the icon «Mirror image up/down» to mirror the stitch pattern contrary to the sewing direction.
- > Touch the yellow-framed icon to reset the alteration to basic setting.

Editing stitch pattern length

The stitch patterns can be lengthwise extended or shortened.

- > Select a stitch pattern or alphabet.
- > Touch the icon «i»-Dialog.



- > Touch the icon «Editing stitch pattern length».
- > Move the slide with the touchscreen pen or the finger to determine the length of the stitch pattern.

- > Touch the icon «+100%» (1) to extend the stitch pattern length in 100%-steps.



- > Touch the yellow-framed icon to reset the alteration to basic setting.

Quick reverse

- > Select a stitch pattern, alphabet or buttonhole.
- > Program needle stop down (permanent) to switch immediately to Quick reverse as soon as the button «Quick reverse» is pressed.
- > Program needle stop up (permanent) to sew another stitch forward before the machine switches to reverse sewing.
- > Press the button «Quick reverse» and keep pressed.

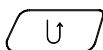

Permanent Quick reverse

- > Select a stitch pattern or alphabet.
- > Touch the icon «i»-Dialog.



- > Touch the icon «Permanent reverse sewing» to sew permanently in reverse.

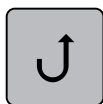

Backstepping

- > Select a stitch pattern, alphabet or a buttonhole.
- > Touch the icon «i»-Dialog.



- > Touch the icon «Backstepping» to backstep the last 200 stitches.



5.5 Securing

Securing with the button «Pattern end»

The button «Pattern end» can be programmed with various functions.



- > Press the button «Pattern end» before sewing is started or while sewing.
 - While sewing, a stop icon indicates that the function is activated and the stitch pattern or the current combination of a stitch pattern will be secured at the end with the programmed number of stitches.

Securing via the icon «Securing»

Every single pattern of a stitch pattern combination can be secured either at the beginning or at the end.



- > Touch the icon «i»-Dialog.



- > Touch the icon «Securing» before starting to sew.
 - The stitch pattern/stitch pattern combination is secured with 4 stitches at the beginning.
- > Touch the icon «Securing» while sewing.
 - The stitch pattern or the active stitch pattern of the stitch pattern combination is secured with 4 stitches at the end.

5.6 Administering stitch patterns

Saving settings of stitch patterns



- > Select a stitch pattern, alphabet or buttonhole.
- > Touch the icon «i»-Dialog.
- > Edit the stitch, alphabet or buttonhole.



- > Touch the icon «Saving stitch pattern settings» to save the alterations permanently.



- > Touch the icon «Back to basic setting» to cancel the alterations.

Saving stitch patterns in personal memory

In the filing system «Personal memory» any stitch patterns, also those which have been individually edited, can be saved. In every file up to maximal 100 stitch patterns can be saved.

- > Select a stitch pattern, alphabet or buttonhole.
- > Edit the stitch pattern.
- > Touch the icon «Personal memory».



- > Touch the icon «Saving stitch pattern».
- > Select the file where the pattern is to be saved.



- > Touch the icon «Confirm».

Overwriting stitch patterns from the personal memory

Prerequisite:

- The stitch pattern is saved in the personal memory.
- > Select a stitch pattern, alphabet or buttonhole.
- > Edit the stitch pattern.
- > Touch the icon «Personal memory».



- > Touch the icon «Saving stitch pattern».
- > Select the file where the stitch pattern to be overwritten has been saved.
- > Select the stitch pattern which should be overwritten.
- > Touch the icon «Confirm».



Loading stitch patterns from the personal memory

Prerequisite:

- The stitch pattern is saved in the personal memory.
- > Touch the icon «Personal memory».



- > Touch the icon «Stitch pattern selection».
- > Select the file where the stitch pattern has been saved.
- > Select a stitch pattern.

Deleting stitch patterns from the personal memory

Prerequisite:

- The stitch pattern is saved in the personal memory.
- > Touch the icon «Personal memory».



- > Touch the icon «Delete».
- > Select the file where the stitch pattern has been saved.
- > Select a stitch pattern.
- > Touch the icon «Confirm» to delete the stitch pattern.



Canceling alterations

Any alterations of stitch patterns can be reset to basic setting, except for those stitch patterns which have been saved in the personal memory.

- > Touch the icon «clr».



5.7 Combi mode

Overview Combi mode



- | | | | |
|---|--------------------------------------------|---|------------------------------------------------|
| 1 | Stitch width of the active stitch pattern | 3 | Combi mode/Single mode |
| 2 | Stitch length of the active stitch pattern | 4 | Individual stitch pattern within a combination |

Creating Stitch pattern combinations

In the Combi mode stitch patterns and alphabets can be combined according to your wish. By combining any alphabet letters, the logo BERNINA can be created.



- > Touch the icon «Single/Combi mode».
- > Select the desired stitch patterns.



- > Touch the icon «Single/Combi mode» again to return to the single mode.

Saving a stitch pattern combination

- > Create a stitch pattern combination.
- > Touch the icon «Personal memory».



- > Touch the icon «Saving the stitch pattern».

- > Touch the icon «Confirm» or the yellow-framed icon to save the stitch pattern combination.



Loading a stitch pattern combination

- > Touch the icon «Single/Combi mode».
- > Touch the icon «Personal memory».
- > Touch the icon «Selection of stitch pattern combination».
- > Select a stitch pattern combination.



Overwriting a stitch pattern combination

- > Create a stitch pattern combination.
- > Touch the icon «Personal Memory».
- > Touch the icon «Saving the stitch pattern».
- > Select the stitch pattern combination which is to be overwritten.
- > Touch the icon «Confirm» to overwrite the stitch pattern combination.



Editing a single stitch pattern

- > Create a stitch pattern combination.
- > With the touchscreen pen or the finger touch the desired position (1) within the stitch pattern combination to select a single stitch pattern.



- > Touch the icon «i»-Dialog to edit the single stitch pattern.

Deleting a single stitch pattern

- > Create a stitch pattern combination .
- > With the touchscreen pen or the finger touch the desired position (1) within the stitch pattern combination to select a single stitch pattern.



- > Touch the icon «i»-Dialog.



- > Touch the icon «Delete» to delete the single stitch pattern.

Adding a single stitch pattern

The new stitch pattern is always added **after** the selected stitch pattern.

- > Create a stitch pattern combination.
- > With the touchscreen pen or the finger touch the desired position (1) within the stitch pattern combination to select a single stitch pattern.



- > Select a new stitch pattern.

Mirroring a stitch pattern combination

- > Create a stitch pattern combination.
- > Touch the icon «i»-Dialog.



- > Touch the icon «Editing the complete combination».



- > Touch the icon «Mirror image left/right» to mirror the complete stitch pattern combination horizontally.
- > Touch the icon «Mirror image left/right» again to reset the alterations to basic setting.



Stitch pattern combination Subdivider 1

A stitch pattern combination can be subdivided into several sections. The subdivision is placed **beneath** the cursor. Only this section is sewn where the cursor is placed. To sew the next section, the cursor must be placed in the next section.

- > Create a stitch pattern combination.
- > With the touchscreen pen or the finger select the desired position within the stitch pattern combination where the stitch pattern combination is to be subdivided.
- > Touch the icon «i»-Dialog.



- > Touch the icon «Editing the combination at cursor position».

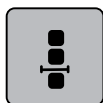

- > Touch the icon «Subdividing the combination».

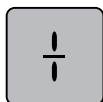

Stitch pattern combination Subdivider 2

A stitch pattern combination can be interrupted at various sections. The interruption is placed **beneath** the cursor.

- > Create a stitch pattern combination.
- > With the touchscreen pen or the finger select the desired position within the stitch pattern combination where the stitch pattern combination is to be interrupted.
- > Touch the icon «i»-Dialog.



- > Touch the icon «Editing the combination at cursor position».

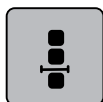

- > Touch the icon «Interrupting the combination».
- > Sew the first section and then reposition the fabric.

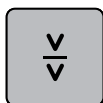

Securing a stitch pattern combination

- > Create a stitch pattern combination.
- > With the touchscreen pen or the finger select the desired position within the stitch pattern combination where the stitch pattern combination is to be secured.



> Touch the icon «i»-Dialog.

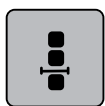

> Touch the icon «Editing the combination at cursor position».



> Touch the icon «Securing».

– Every single pattern of the stitch pattern combination can be secured at the start or at the end.

Programming pattern repeat



> Create a stitch pattern combination.

> Touch the icon «i»-Dialog.

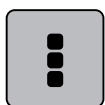

> Touch the icon «Editing the complete combination».



> Touch the icon «Pattern repeat» once to repeat the stitch pattern combination.

> Touch the icon «Pattern repeat» again to repeat the stitch pattern combination up to 9 times.

> Keep the icon «Pattern repeat» pressed to deactivate the pattern repeat.

5.8 Height Compensation of uneven layers

If the presser foot is at an angle when sewing over a thick seam, the feed dog cannot grip the fabric and the sewing project cannot be sewn out properly.

> Place 1 – 3 compensating plates as required from the back of the presser foot close to the needle to level the fabric layer.

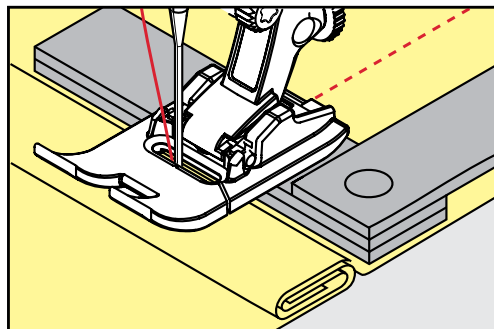

– The presser foot is leveled with the sewing project.

- > Place 1 – 3 compensating plates as required from the front of the presser foot close to the needle to level the fabric layer.

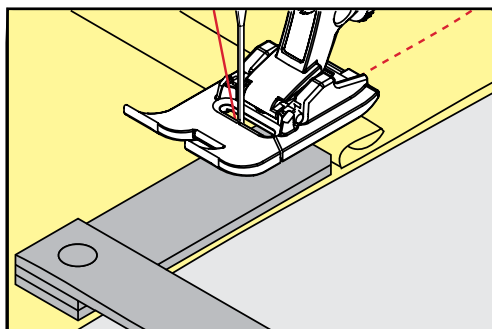

- The presser foot is leveled with the sewing project.
- > Sew until the complete presser foot has passed the thick seam.
- > Remove the plates of the height compensation.

5.9 Sewing Corners

When sewing corners, only a small section of the fabric is actually on the feed dog. Therefore it cannot grip the fabric well. By means of the height compensation tool the fabric can be fed evenly.

- > When the fabric edge is reached, stop the sewing process with needle position down.
- > Raise the presser foot.
- > Turn the fabric and place in desired position.
- > Place 1 – 3 compensating plates as required on the right of the presser foot close to the sewing project.
- > Lower the presser foot.

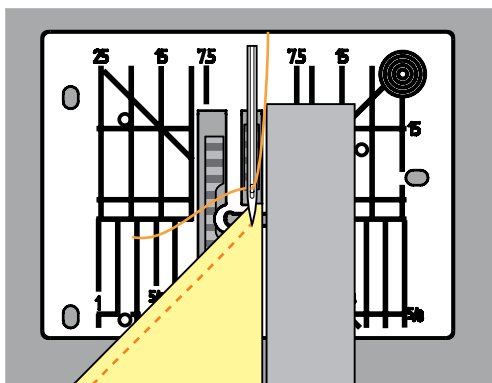

- > Resume sewing until the sewing project is on the feed dog again.

5.10 Using eco mode















During a longer interruption of work the machine can be set into a power save mode. The power save mode also serves as a child safety feature. Nothing can be selected in the display and the machine cannot be started.

















- > Touch the icon «eco».
 - The display goes to sleep. The power consumption is reduced and the sewing light is off.
- > Touch the icon «eco» again.
 - The machine is ready for use.

6 Practical stitches

6.1 Overview Practical stitches

Stitch patterns	Stitch number	Name	Description
	1	Straight stitch	Seams and topstitching.
	2	Zig zag	Reinforcing seams, overcasting edges, sewing elastic seams and attaching lace.
	3	Vari overlock	Sewing and finishing in one step of elastic fabrics.
	4	Running stitch	Darning with running stitch, mending fabrics, reinforcing edges.
	5	Securing Program	Securing starts and ends of seams by straight stitching.
	6	Triple Straight stitch	Reinforced seams in heavy fabrics; visible hems and seams.
	7	Triple Zig zag	Reinforced seams in heavy fabrics; visible hems and seams.
	8	Honeycomb stitch	For stretch fabrics and hems. Is also used with elastic thread in the bobbin..
	9	Blind stitch	Blind hems, shell edging effect on soft jerseys and fine material, decorative seams.
	10	Double overlock	Sewing and finishing in one step of elastic fabrics.
	11	Super stretch stitch	For highly stretch fabrics. For all types of clothing.
	12	Gathering stitch	Most types of fabric; gathering with shirring elastic, butted seams = butting two pressed edges and sewing together, decorative stitches.
	13	Stretch overlock	Sewing and finishing in one step of elastic fabrics.
	14	Tricot stitch	Visible hems, visible seams in lingerie, sweaters, mending jersey.

Stitch patterns	Stitch number	Name	Description
	15	Universal stitch	For firm fabrics such as felt and leather. Flat joining seams, visible seams, attaching elastic, decorative seams.
	16	Sewn-out Zig zag	Edge finishing and reinforcing, attaching elastic, decorative seam.
	17	Lycra stitch	For lycra fabrics; flat joining seams and hems, reinforced seaming on underwear.
	18	Stretch stitch	For highly stretch fabrics; open seam for sportswear.
	19	Reinforced overlock	For medium-weight knitware and toweling; overlock seams, flat joining seams.
	20	Knit overlock	Sewing and finishing in one step of hand and machine knitted fabrics.
	22	Simple Darning Program	Darning of holes and damaged fabric.
	23	Reinforced Darning Program	Reinforcing darning holes and damaged fabric.
	24	Bartack Program	Reinforcing pocket openings, sewing belt loops.
	25	Bartack Program	Reinforcing pocket openings, sewing on belt loops, securing zippers and seam ends.
	26	Large Fly stitch	Reinforcing pocket openings, zippers and slits in medium weight to thick fabrics.
	29	Blindstitch narrow	For blind hems in fine fabrics.
	30	Basting stitch	For basting seams, hems, quilts etc.
	32	Single Straight stitch	Used as a connecting stitch in a combination.
	33	Three Single Straight stitches	As connecting stitches in a combination.

6.2 Sewing straight stitch



Match the stitch length with the sewing project, such as for denim fabrics use long stitches (ca. 3 – 4 mm), for delicate fabrics use short stitches (ca. 2 – 2.5 mm). Match the stitch length with the thread size, such as when edgestitching with Cordonnet, use long stitches (ca. 3 – 5 mm).

The straight stitch, also called step stitch, is the most used stitch.

Prerequisite:

- The Reverse pattern foot No. 1C/1D is attached.
- > Touch the icon «Practical stitches».
 - The Straight stitch No. 1 is selected automatically.



6.3 Securing with the automatic Securing Program

Due to a determined number of 5 stitches sewn forward and 5 stitches sewn backward, the securing is regular.

Prerequisite:

- The Reverse pattern foot No. 1C is attached.
- > Touch the icon «Practical stitches».
- > Select the Securing Program No. 5.
- > Press the foot control.
 - The machine secures automatically.
- > Sew the seam in the desired length.
- > Press the button «Quick reverse».
 - The machine secures automatically and stops at the end of the securing program.

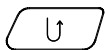

6.4 Sewing in the zipper



As the fabric feed can be difficult when starting to sew, it is recommended to hold the threads firmly or to pull the fabric slightly to the back for a few stitches or to sew 1 - 2 cm reverse first.



- > Attach the Reverse pattern foot No. 1C.
- > Touch the icon «Practical stitches».
 - The Straight stitch No. 1 is selected automatically.
- > Sew the seam up to where the zipper starts.
- > Sew the securing stitches.
- > Close the zipper length with long stitches.
- > Finish the seam allowances.
- > Iron the seam.
- > Open the zipper length.
- > Baste the zipper under the fabric so that the fabric folded edges meet over the center of the zipper.
- > Open the zipper a few centimeters.
- > Attach the Zipper foot No. 4D.
- > Move the needle position to the right.
- > Use the Free Hand System to raise the presser foot and to position the sewing project.
- > Start sewing from top left.
- > Guide the foot so that the needle stitches along the zipper coils.
- > Stop in front of the zipper pull with needle position down.
- > Raise the presser foot.
- > Close the zipper.
- > Continue to sew and stop in front of the base of the zipper with needle position down.
- > Raise the presser foot and turn the sewing project.
- > Sew across the other side of the zipper and stop with needle position down.
- > Raise the presser foot and turn the sewing project.
- > Sew the second side from bottom to top.

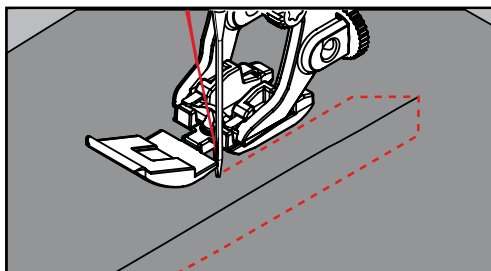

6.5 Sewing both sides of the zipper from bottom to top

It is recommended to sew in the zipper on both sides from bottom to top. This alternative is suitable for all the fabric with nap such as velvet.



When the fabric is firm or densely woven, it is recommended to use a needle with the size 90 – 100. This results in an even stitch formation.



- > Attach the Reverse pattern foot No. 1C.
- > Touch the icon «Practical stitches».
 - The Straight stitch No. 1 is selected automatically.
- > Sew the seam up to the zipper beginning.
- > Sew the securing stitches.
- > Close the zipper length with long stitches.
- > Finish the seam allowances.
- > Iron the seam.
- > Open the zipper length.
- > Baste the zipper under the fabric so that the fabric folded edges meet over the center of the zipper.
- > Attach the Zipper foot No. 4D.
- > Move the needle position to the right.
- > Use the Free Hand System to raise the presser foot and to position the sewing project.
- > Start sewing in the center of the seam at the end of the zipper.
- > Sew diagonally along the edge of the zipper coils.
- > Sew the first side (1) from bottom to top.
- > Stop in front of the zipper pull with needle position down.
- > Raise the presser foot.
- > Open the zipper as far as behind the presser foot.
- > Lower the presser foot and continue sewing.
- > Sew the second side (2) in exactly the same way from bottom to top.

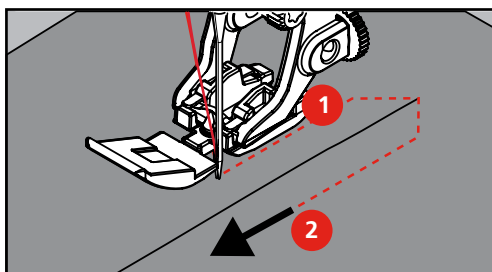

6.6 Sewing triple straight stitch



The triple straight stitch is especially suitable for durable seams and for firm, densely woven fabrics such as denim and corduroy. For firm or densely woven materials it is recommended to attach the Jeans foot No. 8. This will help to sew denim or canvas. For decorative topstitching the stitch length can be elongated.

- > Attach the Reverse pattern foot No. 1C/1D.
- > Touch the icon «Practical stitches».
- > Select the Triple straight stitch No. 6.



6.7 Sewing Triple zig zag

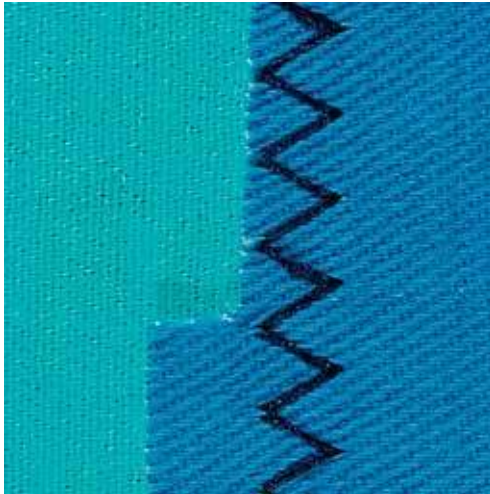

For firm materials such as denim, deckchair covers, awnings or frequently washed items. Finish raw edges first.

- > Attach the Reverse pattern foot No. 1C/1D.
- > Touch the icon «Practical stitches».
- > Select the Triple zig zag No. 7.



6.8 Manual darning



Used for darning holes or worn areas in all fabric types.

If the thread is lying on top and a poor stitch formation results, slow down the movement of the sewing project. If there are knots on the wrong side of the fabric, move the sewing project faster. When the thread breaks, guide the sewing project more consistently.



- > Attach the Darning foot No. 9 (optional accessory).
- > Touch the icon «Practical stitches».
 - The Straight stitch No. 1 is selected automatically.
- > Lower the feed dog.
- > Attach the slide-on table.
- > Hoop the sewing project in the round embroidery hoop (optional accessory).
 - The darning area stays evenly taut and cannot be distorted.
- > Sew from the left to the right, guide the fabric evenly by hand without using pressure.
- > Move in curves when changing the direction to avoid holes and thread breakage.
- > Work the rows in irregular lengths so that the thread is better spread over the fabric.

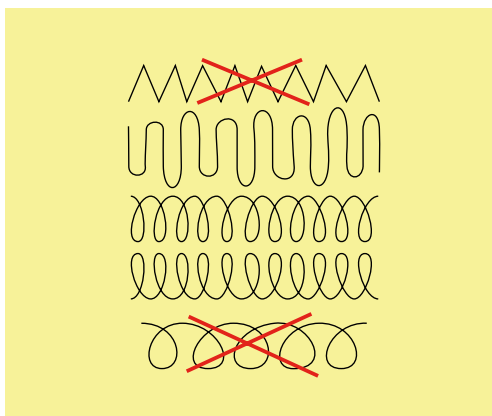

- > Sew the first rows not too close together and beyond the worn area.

- > Sew the rows in irregular lengths.

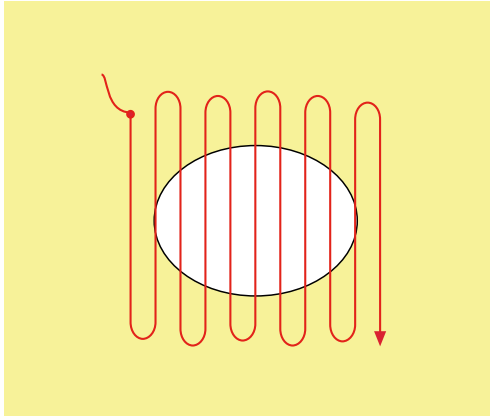

- > Turn the sewing project by 90°.
- > Sew the first rows not too close.

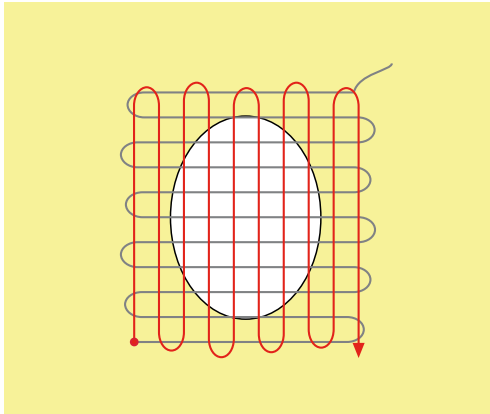

- > Turn the sewing project by 180°.
- > Sew another loose row.

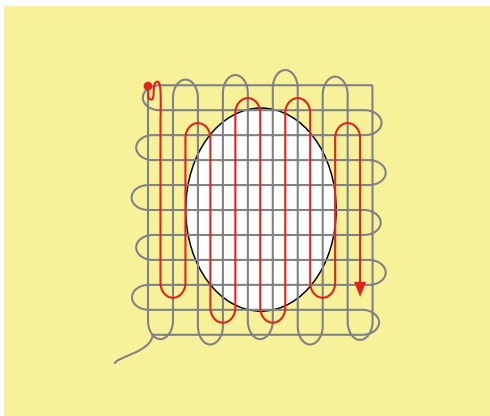

6.9 Automatic darning



The simple Darning Program No. 22 is especially suitable for quick darning of worn or damaged areas. It is recommended to use fine material as a backing for the worn and damaged areas or to stick an adhesive interlining. The simple Darning Program No. 22 replaces threads along the lengthwise grain in all materials. If the darning area becomes distorted, correct with the balance.

- > Attach the Reverse pattern foot No. 1C or the Buttonhole foot No. 3A.
- > Touch the icon «Practical stitches».
- > Select the simple Darning Program No. 22.
- > Hoop light weight materials in the round embroidery hoop (optional accessory).
 - The darning area stays evenly taut and cannot be distorted.
- > Start sewing top left.
- > Sew the first row.
- > Stop the machine.
- > Press the button «Quick reverse».
 - The length is programmed.
- > Finish sewing the Darning Program.
 - The machine stops automatically.

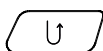

6.10 Reinforced darning, automatic

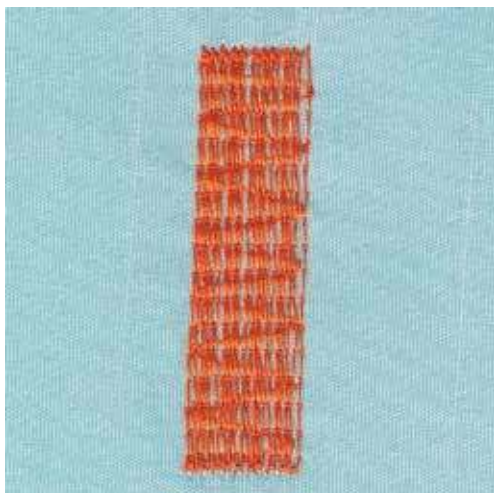

The reinforced Darning Program No. 23 is especially suitable for quick darning of worn or damaged areas. The reinforced Darning Program No. 23 replaces threads along the lengthwise grain in all materials.



If the Darning Program does not cover the whole worn or damaged area, it is recommended to reposition the work and the sew the Darning Program again. The length is programmed and can be repeated as often as desired.

Via the direct entry length, a darning length up to 30 mm can be programmed

- > Attach the Buttonhole foot No. 3A.
- > Touch the icon «Practical stitches».
- > Select the reinforced Darning Program No. 23.
- > Hoop light weight materials in the round embroidery hoop (optional accessory).
 - The darning area stays evenly taut and cannot be distorted.
- > Start sewing top left.
- > Sew the first row.
- > Stop the machine.
- > Press the button «Quick reverse».
 - The length is programmed.
- > Finish sewing the Darning Program.
 - The machine stops automatically.

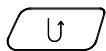

6.11 Finishing edges



The Zig zag No. 2 is suitable for all materials. It can also be used for elastic seams as well as for decorative sewing. Use darning thread for fine materials. When sewing satin stitch it is recommended to select a dense, short the zig zag with a stitch length of 0.5 – 0.7 mm. The satin stitch can be used for appliqué and for embroidering.

Prerequisite:

- The edge of the fabric should lie flat and not roll.
- > Attach the Reverse pattern foot No. 1C.
- > Touch the icon «Practical stitches».
- > Select the Zig zag No. 2 or the Satin stitch No. 1354.
- > Neither select too wide a stitch nor too long a stitch.
- > Guide the edge of the fabric into the center of the presser foot, so that the needle goes into the fabric on one side and over the edge into the air on the other side.



6.12 Sewing Double overlock



A double overlock seam is suitable for loose knits and cross seams in knits. When working with jersey, a jersey needle should be used to prevent damaging the knit fabric. When sewing stretch materials, use a stretch needle.

- > Attach the Reverse pattern foot No. 1C or the Overlock foot No. 2A.
- > Touch the icon «Practical stitches».
- > Select the Double overlock No. 10.



6.13 Narrow edgestitching

- > Attach the Blindstitch foot No. 5 (optional accessory) or the Reverse pattern foot or the Edge stitch foot No. 10/10C/10D (optional accessory).
- > Touch the icon «Practical stitches».
 - The Straight stitch No. 1 is selected automatically.
- > Place the edge on the left against the guide of the Blindstitch foot.
- > Select the needle position left in the desired distance to the edge.

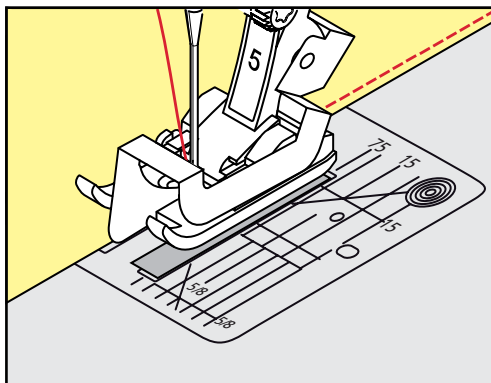

6.14 Wide edgestitching

- > Attach the Reverse pattern foot No. 1C or the Edge stitch foot No. 10/10C/10D (optional accessory).
- > Touch the icon «Practical stitches».
 - The Straight stitch No. 1 is selected automatically.
- > Guide the folded edge at a distance of 1 – 2.5 cm along either the presser foot or the marks.



- > Select the needle position in the desired distance to the edge.

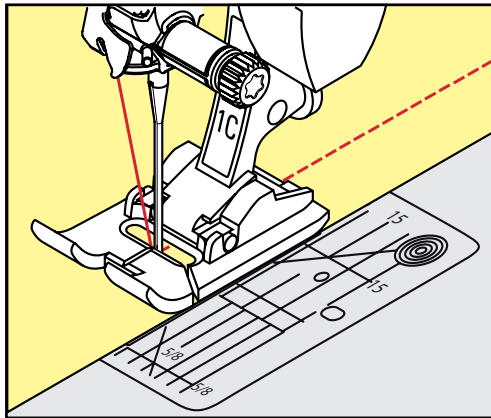

6.15 Edgestitching using the seam guide

When sewing parallel wider lines, it is recommended to guide the seam guide along the sewn of lines.

- > Attach the Reverse pattern foot No. 1C or the Edge stitch foot No. 10/10C/10D (optional accessory).
- > Touch the icon «Practical stitches».
 - The Straight stitch No. 1 is selected automatically.
- > Loosen the screw on the back of the presser foot.
- > Insert the seam guide into the hole of the presser foot.
- > Adjust the width as desired.
- > Tighten the screw.
- > Guide the folded edge along the seam guide.

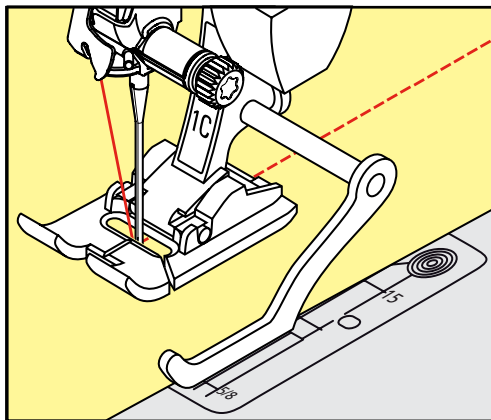

6.16 Sewing hem edges

When using the Blindstitch foot No. 5, it is recommended to select a needle position far left or far right. When using the Reverse pattern foot No. 1C or the Edge stitch foot No. 10/10C/10D (optional accessory) all needle positions are possible.

- > Attach the Blindstitch foot No. 5 (optional accessory) or the Reverse pattern foot No. 1C or the Edge stitch foot No. 10/10C/10D (optional accessory).
- > Touch the icon «Practical stitches».
 - The Straight stitch No. 1 is selected automatically.
- > Place the inside upper edge right against the guide of the Blindstitch foot.



- > Choose the needle position far right to sew along the upper edge.

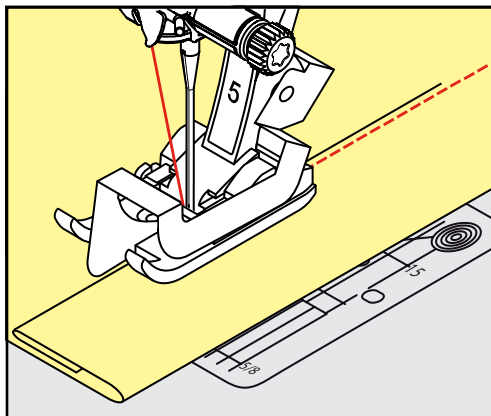

6.17 Sewing blind hems

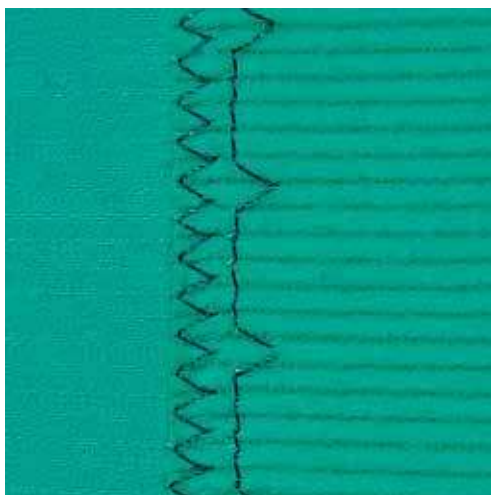

For invisible hems in medium to heavy weight cotton, wool and blended materials.

Prerequisite:

- The raw edges are finished.
- > Attach the Blindstitch foot No. 5 (optional accessory).
- > Touch the icon «Practical stitches».
- > Select the Blindstitch No. 9.
- > Fold the fabric back over the right side of the fabric to expose the finished lower edge.
- > Place the fabric under the presser foot and move the folded edge against the metal guide on the presser foot.
- > Guide the folded edge evenly along the metal guide of the foot to sew the stitches evenly deep.
 - Make sure that the needle only pierces the edge of the fold.



- > Check the blind hem on both fabric sides again after about 10 cm and adjust the stitch width if necessary.

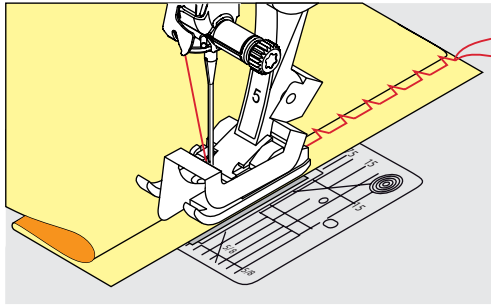

6.18 Sewing visible hems



The visible hem is especially suitable for elastic hems in jersey, cotton, wool, synthetic and mixed fibers.



- > Attach the Reverse pattern foot No. 1C/1D.
- > Touch the icon «Practical stitches».
- > Select Tricot stitch No. 14.
- > Iron the hem and baste if necessary.
- > Reduce the presser foot pressure if necessary.
- > Sew the hem at the preferred depth on the right side.
- > Trim the excess fabric from the wrong side.

6.19 Sewing flat joining seams

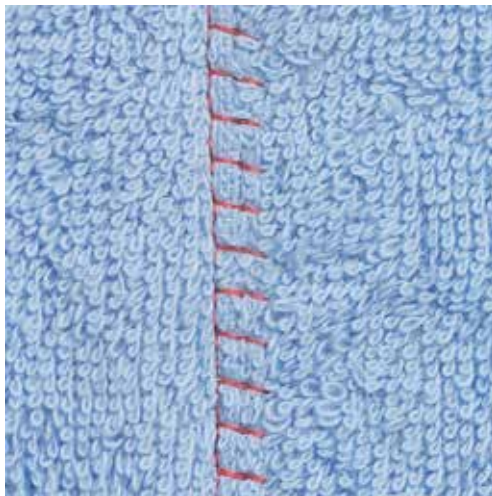

The flat joining seam is especially suitable for or thick materials such as terry cloth, felt and leather.



- > Attach the Reverse pattern foot No. 1C.
- > Touch the icon «Practical stitches».
- > Select the Stretch overlock No. 13.
- > Overlap the fabric edges.
- > Sew along the fabric edge.
- > The needle stitches over the edge of the top layer on the right side into the bottom layer to get a very flat durable seam.

6.20 Sewing basting stitches

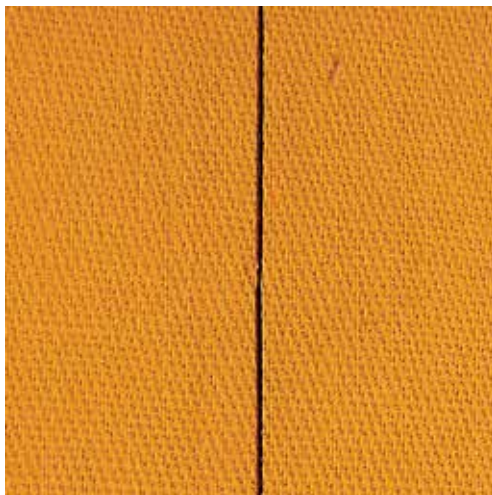

When sewing basting stitches, it is recommended to use a fine darning thread as this is easier to remove. The basting stitch is suitable for sewing projects where a very long stitch length is required.



- > Attach the Basting foot No. 9 (optional accessory).
- > Lower the feed dog.
- > Touch the icon «Practical stitches».
- > Select the Basting stitch No. 30.
- > Pin the fabric layers at a right angle to basting direction to prevent the layers from slipping.
- > Hold the threads and sew 3 – 4 securing stitches at the beginning.
- > Sew a stitch and pull the fabric to the back at the desired stitch length.
- > Sew a stitch.
- > Sew 3 – 4 securing stitches at the end.







7 Decorative stitches

7.1 Overview Decorative Stitches

Depending on the type of material, simple or more complex decorative stitches should be selected to best suit the fabric.

- Decorative stitches which are programmed with simple straight stitches are particularly appropriate for light weight materials, such as the Decorative stitch No. 101.
- Decorative stitches which are programmed with triple straight stitches or with a few satin stitches are particularly appropriate for medium weight materials, such as the Decorative stitch No. 107.
- Decorative stitches which are programmed with satin stitches are particularly appropriate for heavy materials, such as the Decorative stitch No. 401.

For a perfect stitch formation it is of advantage to use the same thread color for upper and bobbin thread and a stabilizer. With pile or longfiber materials it is recommended to use an additional, water-soluble stabilizer on the right side which can be easily removed after sewing.

Decorative stitch	Category	Name
	Category 100	Florals
	Category 300	Cross stitches
	Category 400	Satin stitches
	Category 600	Ornamental stitches
	Category 700	Heirloom stitches
	Category 900	Novelty

7.2 Bobbin-Play



NOTICE Inappropriate bobbin case is used.

Damage of the bobbin case.

> Use the bobbin case (optional accessory).

The bobbin can be filled with different thread material. For free-motion stitching to add texture. This method is similar to «normal» free-motion sewing, but is done on the **wrong** side of the fabric.

Reinforce the area to be sewn with embroidery stabilizer. The design can be drawn on the wrong side of the fabric. You can also draw the design on the front side of the fabric. The lines can be followed with a freely guided straight stitch using polyester, cotton or rayon thread. The rows of stitching are visible on the right side of the fabric, and serve as reference lines for the bobbin-thread sewing.

The BSR function can be used for bobbin-thread sewing. It is recommended to guide your project at consistent speed evenly under the needle, following the lines of the design. The stabilizer must be removed after sewing.

Sew a sample first to check what the result looks like on the wrong side of the fabric.

Not all decorative stitches are suitable for this technique. Simple decorative stitches provide best results.

Avoid compact stitch types and satin stitches.

> Attach the Embroidery No. 20C or No. 20D (optional accessory).

> Touch the icon «Decorative stitch».

> Select the appropriate decorative stitch.

> Turn the «Upper Multifunctional knob» and the «Lower Multifunctional knob» to adjust the stitch length and the stitch width so that even when sewing with thick thread a nice stitch formation can be achieved.

> Touch the icon «Upper thread tension» to adjust the upper thread tension if necessary.



7.3 Sewing cross stitches

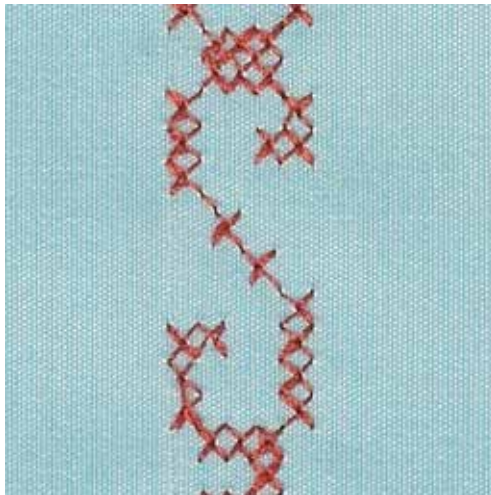
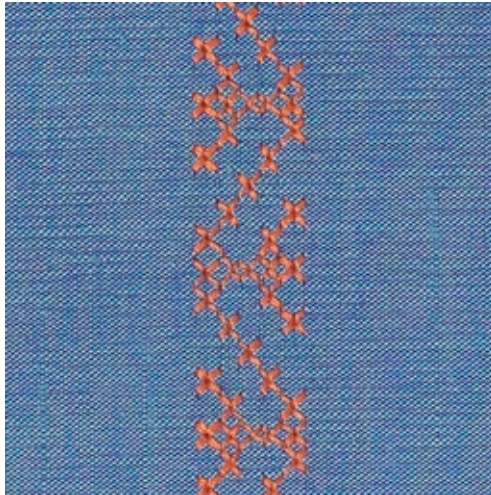





Cross stitching is a traditional technique, and extends the range of decorative stitches. If the cross stitches are sewn on fabric with a linen texture, they look like hand-stitched cross stitching. When cross stitches are sewn with cotton embroidery thread, the stitch pattern appears fuller. Cross stitches are particularly used for home furnishing, trimmings on garments and embellishing in general. As every following line refers to the first row, it is important to stitch the first row in a straight line.

- > Attach the Reverse pattern foot No. 1C/1D or the Open Embroidery foot No. 20C or the Embroidery foot No. 20D (optional accessory).
- > Select a cross stitch of the Category 300 and combine it as desired.
- > Stitch the first row using the seam guide or slide-on table seam guide to sew a straight line.
- > Stitch the second row next to the first at a distance of one presser foot's width or using the seam guide.

7.4 Pintucks

This technique reduces the size of the fabric which means that always enough fabric should be calculated. Pintucks are narrow stitched folds which are normally sewn on the fabric before cutting out the pieces for garments or other sewing projects. They are suitable for embellishing or in combination with other heirloom embroidery techniques.

A more distinctive and relief-like effect can be achieved when the pintucks are corded, which means that they are sewn with an additional pintuck cord. Choose a pintuck cord that fits well into the grooves of the selected pintuck foot. The cord must be colorfast and shrinkproof.

Pintuck foot	Number	Description
	30 (optional accessory) 3 grooves	4 mm double needle: for heavy fabrics.
	31 (optional accessory) 5 grooves	3 mm double needle: for heavy to medium weight fabrics.
	32 (optional accessory) 7 grooves	2 mm double needle: or light to medium weight fabrics.
	33 (optional accessory) 9 grooves	1 or 1.6 mm double needle: for very light fabrics (without pintuck cord).
	46C (optional accessory) 5 grooves	1.6 – 2.5 mm double needle: for light to medium weight fabrics.

Inserting the cord

- > Switch the machine off and disconnect it from the power supply system.
- > Remove the needle.
- > Remove the presser foot.
- > Remove the stitch plate.
- > Open the bobbin cover.
- > Pull the cord through the hook opening from the bottom and through the opening of the stitch plate.
- > Replace the stitch plate.
- > Close the bobbin cover.
- > Make sure that the cord slides through the thread slot of the bobbin cover.

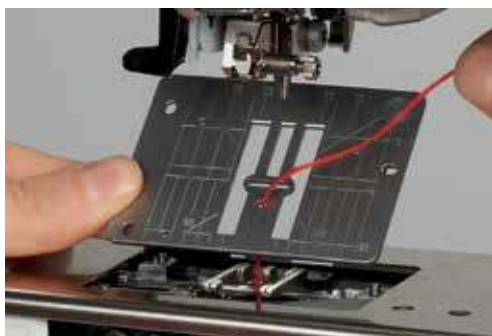

- > Place the cord spool on the arm of the Free Hand System.



- > Check that the cord runs smoothly.
- > If the thread doesn't slide smoothly past the bobbin cover, open the cover while sewing and turn off the bobbin thread indicator in the Setup Program.

Sewing Pintucks

The cord lies on the wrong side of the material and is hold/sewn over by the bobbin thread.

- > Sewing the first pintuck.
- > Place the first pintuck in one of the side grooves in the presser foot.
- > Sew additional pintucks parallel.

8 Alphabets

8.1 Overview Alphabet

Block, Double block, Script and Comic alphabets as well as as Cyrillic can be sewn in two different sizes.

Block, Double block, Script and Comic alphabets as well as as Cyrillic can also be sewn in lower case letters.

For a perfect stitch formation it is recommended to use the same thread color for upper and bobbin threads.

The fabric can be reinforced with embroidery stabilizer on the wrong side. Use an additional, water-soluble stabilizer on the right side of pile or napped fabrics.

Stitch patterns	Name
ABCabc	Block alphabet
ABCabc	Double-Block
<i>ABCabc</i>	Script (Italics)
АБВабв	Cyrillic
あいう	Hiragana

8.2 Creating lettering



- > Touch the icon «Alphabets».
- > Select the font.



- > Touch the icon «Single/Combi mode» to create a combination.
- > Touch the icon «Adjusting the view» (1) to open the expanded enter mode.



- > Select the letters.
- > Touch the icon (1) (standard setting) to use upper case letters.
- > Touch the icon (2) to use lower case letters.
- > Touch the icon (3) to use numbers and mathematic symbols.

- > Touch the icon (4) to use special characters.



- > Touch the icon «DEL» to delete single letters of the entered text.
- > Touch the icon «Adjusting the view» again to close the expanded enter mode.

8.3 Altering font size

Block, Double block, Script and Comic alphabets as well as Cyrillic can be downloaded.



- > Touch the icon «Alphabets».
- > Select the font.
- > Select the letters.
- > Touch the icon «i»-Dialog.















- > Touch the icon «Altering font size» to downsize the lettering.
- > Touch the icon «Altering font size» again to scale up the lettering to 9 mm.

9 Buttonholes

9.1 Overview Buttonholes

To create the correct buttonhole for every button, every purpose and for every garment, your BERNINA 740 is equipped with a considerable collection of buttonholes. corresponding button can be sewn on automatically. Eyelets can also be sewn.

Buttonhole	Buttonhole number	Name	Description
	51	Standard buttonhole	For light to medium weight fabrics; blouses, dresses, bedlinens.
	52	Standard buttonhole narrow	For light to medium weight fabrics; blouses, dresses, children's and baby clothes, crafts.
	53	Stretch buttonhole	For any highly elastic jersey made from cotton, wool, silk and synthetic fibers.
	54	Round buttonhole with normal bartack	For medium to heavy weight fabrics: dresses, jackets, coats, rainwear.
	56	Keyhole buttonhole	For heavy weight, non-stretch fabrics; jackets, coats, leisure wear.
	57	Keyhole buttonhole with pointed bartack	For firmer, non-stretch fabrics: jackets, coats, leisure wear.
	59	Straight stitch buttonhole	Program for staystitching buttonholes, for pocket openings, reinforcing buttonholes, especially for buttonholes in leather and imitation leather.
	63	Heirloom	For light to medium weight woven fabrics; blouses, dresses, leisure wear, bedlinen.
	69	Decorative buttonhole with double pointed bartack	For decorative buttonholes in firmer, non-elastic fabrics.
	60	Button sew-on program	For buttons with 2 and 4 holes.
	61	Eyelet with small zig zag	Openings for cords and narrow ribbons, for decorative work.
	62	Straight-stitch eyelet	Openings for cords and narrow ribbons, for decorative work.

9.2 Making use of the height compensation tool

When a buttonhole is to be sewn at right angles to the project edge, it is recommended to use the height compensation plates (optional accessory).

- > Place the plates from the back between the sewing project and the bottom of the slide to the thick part of the sewing project.

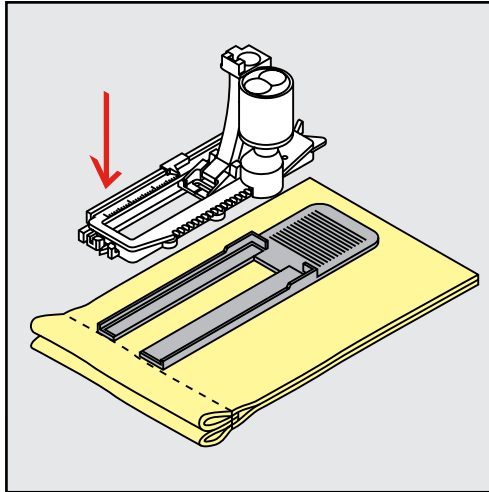

- > Lower the presser foot.

9.3 Using the compensation plate

When sewing a buttonhole in difficult materials, it is recommended to use the compensation plate for buttonholes (optional accessory). It can be used along with the Buttonhole foot No. 3A.

- > Insert the compensation plate carefully from the side.

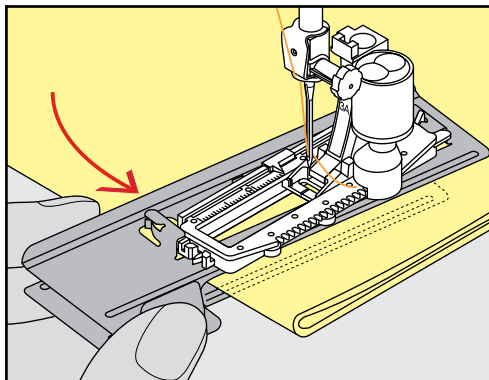

9.4 Marking buttonholes

- > For the buttonholes to be sewn manually, mark the position and the length on the fabric using chalk or a water-soluble pen.

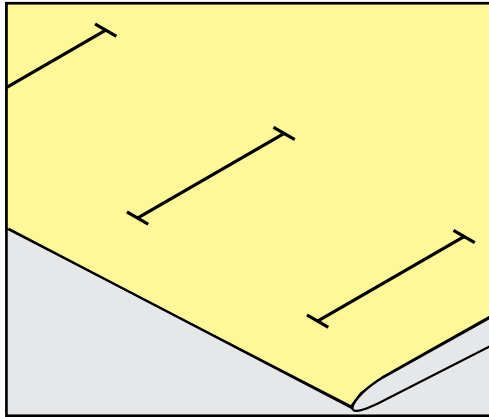

- > For the buttonholes to be sewn automatically, mark the complete length of 1 buttonhole on the fabric using chalk or a water-soluble pen. For any subsequent buttonholes mark the starting point.

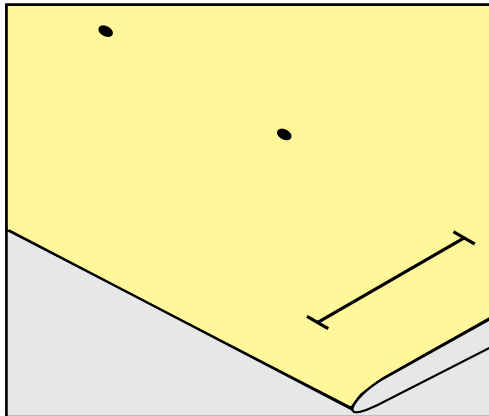

- > For keyhole and round buttonholes mark the length of the bead with chalk or a water-soluble pen on the fabric. For any subsequent buttonholes mark the starting point. The length of the keyhole is sewn additionally.

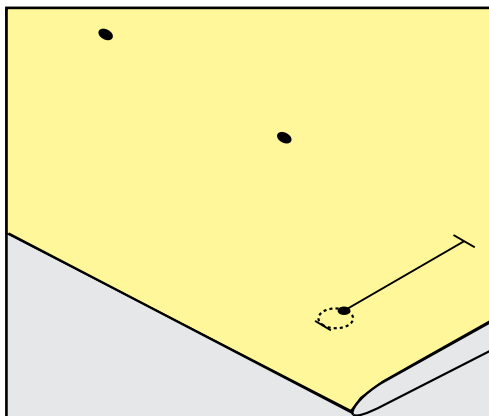

9.5 Cord

Using cord with the Buttonhole foot with slide No. 3A

The cord reinforces and enhances the buttonhole and is particularly suitable for the Buttonhole No. 51. Optimal cord is Perle cotton No. 8, strong hand-sewing thread and fine crochet yarn. It is recommended not to hold the cord when sewing.

Prerequisite:

- The Buttonhole foot with slide No. 3A is attached and raised.
- > Insert the needle at the beginning of the buttonhole.
- > Guide the cord on the right side under the buttonhole foot.
- > Hook the cord over the pin at the back of the buttonhole foot.

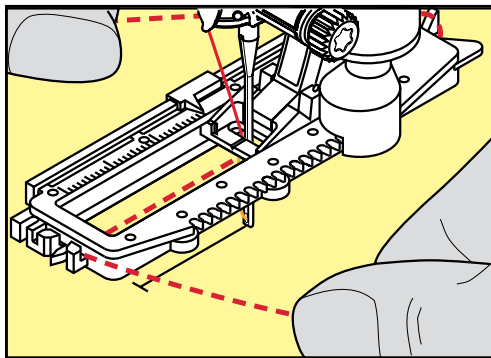

- > Pull the cord on the left side under the buttonhole foot to the front.

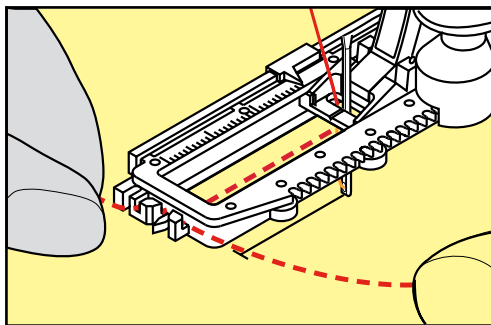

- > Pull the cord ends into the slits.
- > Lower the buttonhole foot.
- > Sew the buttonhole in the usual manner.
- > Pull the cord through the buttonhole until the loop disappears in the bartack.

- > Pull the ends of the cord through to the wrong side of the fabric (using a hand stitching-needle), knot or secure with stitches.

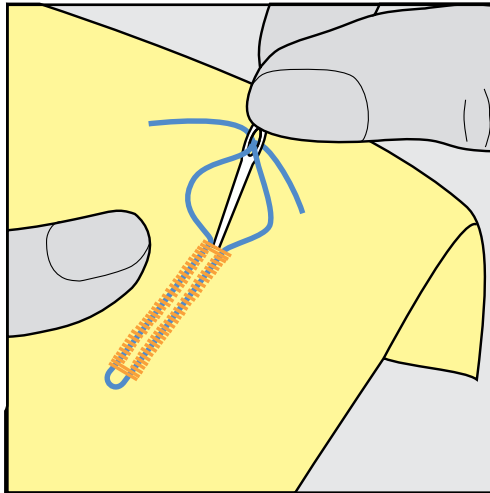

Using cord with the Buttonhole foot No. 3C (optional accessory)

Prerequisite:

- The Buttonhole foot No. 3C (optional accessory) is attached and raised.
- > Insert the needle at the beginning of the buttonhole.
- > Hook the cord over the pin at the back of the buttonhole foot.

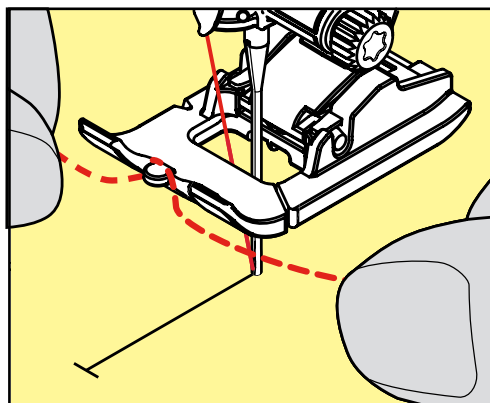

- > Pull both cords ends under the buttonhole foot to the back and place each a cord into a groove of the sole.

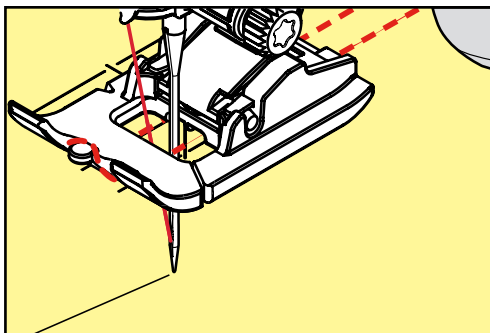

- > Lower the buttonhole foot.
- > Sew the buttonhole in the usual manner.
- > Pull the cord until the loop disappears in the bartack.

- > Pull the ends of the cord with a hand stitching-needle to the wrong side of the fabric and knot or secure.

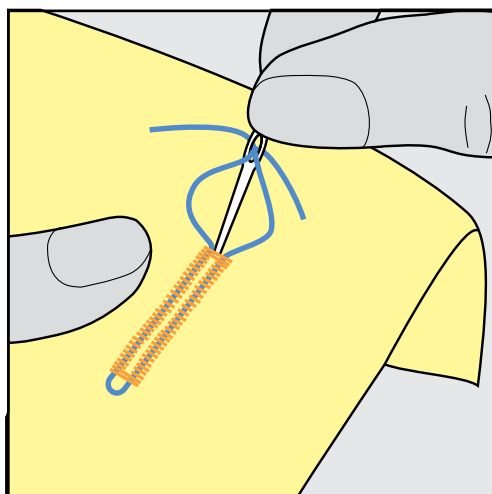

9.6 Sewing a test sample

Always sew a test sample of the buttonhole on the same fabric: It is recommended to use the same stabilizer and to select the same buttonhole. The test sample should also be sewn in the respective direction. By sewing a test sample the settings can be adjusted until the sewing result is satisfying.

Alterations of the balance when sewing a manual standard buttonhole as well as the keyhole and the round buttonhole affect both beads in the same way. With the manual keyhole or round buttonhole the alterations affect both sides differently.

If the stitch counter function is used and alterations are made concerning the balance, the alterations affect both buttonhole beads differently.



- > Touch the icon «Buttonholes».
- > Select the buttonhole.
- > Select and attach the desired presser foot.
- > Place the fabric under the presser foot and lower the presser foot.
- > Press the foot control carefully and start sewing. Guide the fabric slightly.
- > Check the balance while sewing and adjust if necessary.
- > Check the test sample and make further amendments if necessary.

9.7 Determining the buttonhole slit width

The width of the buttonhole slit can be adjusted between 0.1 – 2.0 mm before sewing.



- > Touch the icon «Buttonholes».
- > Select the buttonhole.



- > «i»-Dialog.

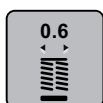

- > Touch the icon «Buttonhole slit width».
- > Turn the «Upper Multifunctional knob» or the «Lower Multifunctional knob» to adjust the buttonhole slit width as desired.
- > Touch the yellow-framed icon to reset the alteration to basic setting.

9.8 Determining the buttonhole length



The button can be centered in the yellow circle in the lower portion of the display. The yellow circle can be enlarged or downsized with the «Multifunctional knobs up/down» and the diameter of the button can be determined in this way.

Additionally to the diameter of the button, 2 mm are added automatically for the buttonhole length. If the diameter of the button is 14 mm, the buttonhole length is calculated 16 mm.



- > Touch the icon «Buttonholes».
- > Select the buttonhole.



- > Touch the icon «i»-Dialog.

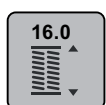

- > Touch the icon «Adjusting the buttonhole length».
- > Turn the «Upper Multifunctional knob» or the «Lower Multifunctional knob» to adjust the buttonhole length.
- > Touch the yellow-framed icon to reset the alterations to basic setting.

9.9 Using the stitch counter function

The stitch counter function is suitable for all types of buttonholes. The left buttonhole bead is sewn forward, the right buttonhole bead is sewn in reverse. If alterations of the balance are made, the stitch counter function has to be saved for every buttonhole separately.

Prerequisite:

- The Buttonhole foot No. 3C (optional accessory) is attached.



- > Touch the icon «Buttonholes».
- > Select the buttonhole.



- > Touch the icon «i»-Dialog.



- > Touch the icon «Stitch counter buttonhole».
- > Sew the desired buttonhole length.
- > Stop the machine.

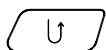

- > Press the button «Quick reverse» so that the machine sews the lower bartack and the second bead in reverse.
- > Stop the machine at the height of the first stitch.
- > Press the button «Quick reverse» again so that the machine sews the upper bartack and the securing stitches.
 - The length of the buttonhole remains saved and every subsequent buttonhole is sewn identically until the machine is switched off.

9.10 Sewing a buttonhole automatically



When the Buttonhole foot with slide No. 3A is used, the length of the buttonhole is measured automatically by the lens on the presser foot. The buttonhole will be duplicated and the machine switches to the next step automatically when the maximum length is reached. The Buttonhole foot with slide No. 3A is suitable for buttonholes in the length of 4 – 31 mm, depending on the buttonhole type. The slide of the Buttonhole foot must lie perfectly flat on the fabric so that the length can be measured accurately. All the programmed buttonholes are the same length and of the same nice look.

Prerequisite:

- The Buttonhole foot with slide No. 3A is attached.



- > Touch the icon «Buttonholes».
- > Select the buttonhole No. 51 – 53 or 54, 56, 57 or No. 69.
- > Sew the desired buttonhole length.

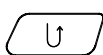

- > Push the button «Quick Reverse» to programm the length.
- > Push the button «Start/Stop» or press the foot control.
 - The machine finishes the buttonhole automatically. All the subsequent buttonholes are sewn at the same length.

9.11 Programming the Heirloom buttonhole

Prerequisite:

- The Buttonhole foot with slide No. 3A is attached.



- > Touch the icon «Buttonholes».
- > Select the Buttonhole No. 63.
- > Sew the desired buttonhole length.

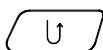

- > Press the button «Quick reverse» to program the length.
 - The machine finishes the buttonhole automatically. All subsequent buttonholes are sewn at the same length.

9.12 Sewing the manual 7-step buttonhole

The buttonhole length is determined manually while sewing. The bartack, the keyhole and the securing stitches are pre-programmed. The individual steps can be selected via scrolling with the arrow icons or by pressing the button «Quick Reverse».

Prerequisite:

- The Buttonhole foot No. 3C (optional accessory) is attached.



- > Touch the icon «Buttonholes».
- > Select the buttonhole No. 51.



- > Touch the icon «i»-Dialog.



- > Touch the icon «Adjust the length manually».
 - Step 1 in the display is activated for the buttonhole start.
- > Sew the desired buttonhole length.
 - Step 2 is activated.



- > Stop at the desired length of the buttonhole or at the marking.
- > Touch the icon «Scrolling down» so that step 3 appears.
- > Stop at the height of the first stitch at the buttonhole start.
- > Touch the icon «Scrolling down» so that step 4 appears.
 - The machine sews the upper bartack and stops automatically.
- > Touch the icon «Scrolling down» so that step 5 appears.
 - The machine sews the second bead.

- > The machine stops at the height of the last stitch of the first bead.
- > Touch the icon «Scrolling down» do that step 6 appears.
 - The machine sews the lower bartack and stops automatically.
- > Touch the icon «Scrolling down» so that step 7 appears.
 - The machine stops and secures automatically.

9.13 Sewing the manual 5-step buttonhole

The length of the beads is manually determined when sewing. Bartack, eye and securing stitches are preprogrammed. The individual steps can also be selected by scrolling via the arrow icons, by direct selection or by touching the button Quick reverse.

Prerequisite:

- The Buttonhole foot No. 3C (optional accessory) is attached.



- > Touch the icon «Buttonholes».
- > Select the buttonhole No. 56.



- > Touch the icon «i»-Dialog.



- > Touch the icon «Adjusting the length manually».
 - Step 1 in the display is activated the buttonhole start.
- > Sew the desired buttonhole length.
 - Step 2 is activated.



- > Stop at the desired length of the bead or at the marking.
- > Touch the icon «Scrolling down» so that step 3 appears.
- > The machine sews the keyhole or the eye and stops automatically.
- > Touch the icon «Scrolling down» so that step 4 appears.
 - The machine sews the second bead in reverse.
- > Stop the machine at the height of the first stitch at the buttonhole start.
- > Touch the icon «Scrolling down» so that step 5 appears.
 - The machine sews the upper bartack and secures automatically.

9.14 Cutting the buttonhole open with the seam ripper

- > Place a pin in each end of the buttonhole to avoid accidental cutting into ends of buttonhole.
- > Cut the buttonhole from both ends to the middle.

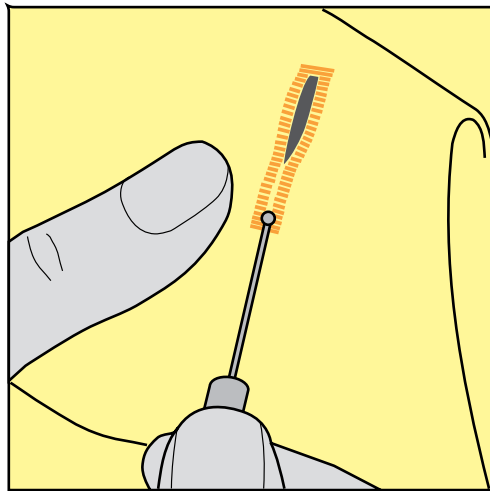

9.15 Cutting open buttonholes with the buttonhole cutter (optional accessory)

- > Place the fabric on an appropriate wood.

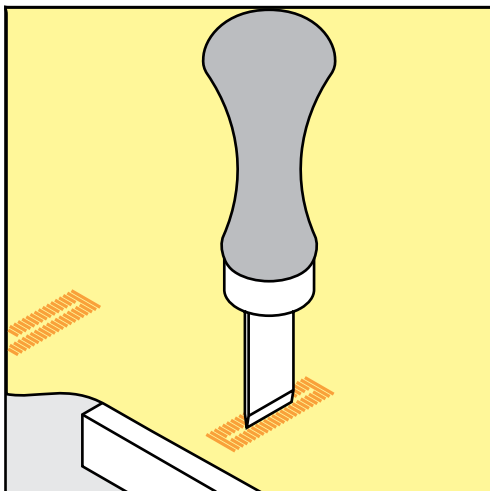

- > Position the cutter in the center of the buttonhole.
- > Press down on the cutter with your hand.

9.16 Sewing on buttons

With the Button sew-on Program buttons with 2 or 4 holes can be sewn on. To reinforce the stability the Button sew-on Program can be sewn twice. When sewing on a button with 4 holes, the front holes should be sewn first.

Buttons sewn on for decorative purposes only are stitched without a thread shank. The shank height is the distance between the button and the fabric. When using the Button sew-on foot No. 18 (optional accessory), the shank height can be adjusted with the screw.

With the Button sew-on Program the first securing stitch is always stitched into the left hole of the button.

Prerequisite:

- The Darning foot No. 9 (optional accessory) or the Button sew-on foot No. 18 (optional accessory) is attached.
- > Lower the feed dog.
- > Select the Button sew-on Program No. 60.
- > Place the button on the sewing project.
- > Turn the handwheel to adjust the distance between the holes.
- > Hold the threads when starting to sew and, if necessary, alter the stitch width.
 - The machine sews the Button sew-on Program and stops automatically.
- > Pull on both bobbin threads until the ends of the upper threads are visible on the wrong side.
- > Knot the ends manually.

9.17 Sewing eyelets















For increased stability sew the eyelet twice.

Prerequisite:

- The Reverse pattern foot No. 1C or the Open embroidery foot No. 20C is attached.
- > Select the Eyelet Program No. 61 or No. 62.
- > Turn the «Upper Multifunctional knob» or the «Lower Multifunctional knob» to alter the size of the eyelet.
- > Sew the Eyelet Program.
 - The machine stops automatically at the end of the Eyelet Program.
- > Use an awl, punch pliers or a hole punch to open the eyelet.

10 Quilting

10.1 Overview Quilt Stitches

Stitch patterns	Stitch number	Name	Description
	1324	Quilting, Securing Program	To secure at the sewing start and sewing end with short stitches forward.
	1325	Quilting straight stitch	Straight stitch at 3 mm stitch length.
	1327	Stippling stitch	Imitation of stipple quilting.
	1328	Handlook quilt stitch	Imitation of handlook quilt stitch with monofilament.
	1329	Blanket stitch	For appliqué and sewing on ribbons.
	1330	Double blanket stitch	For appliqué and sewing on ribbons.
	1331	Blindstitch narrow	To sew blind stitches.
	1332	Feather stitch	For "Crazy Patchwork" and embellishing.
	1333	Feather stitch variations 1334, 1336	For "Crazy Patchwork" and embellishing.
	1339	Decorative quilt stitch variations 1339, 1355 – 1359	For "Crazy Patchwork" and embellishing.
	1346	Quilt stitch/Handlook stitch variations 1346, 1347, 1348	Imitation of stipple quilting, to use with monofilament.
	1352	Blanket stitch dual	To edgestitch between two appliqués, "Crazy Patchwork".
	1353	Double blanket stitch dual	To edgestitch between two appliqués, "Crazy Patchwork".
	1354	Satin stitch	For appliqué.

10.2 Sewing in the Quilting securing Program

Prerequisite:

- The Reverse pattern foot No. 1C/1D is attached.
- > Select Quilt stitch pattern No. 1324.
- > Press the foot control.
 - The machine sews 6 stitches forward automatically when sewing is started.
- > Sew the seam at the desired length.
- > Press the button «Quick reverse».
 - The machine sews 6 stitches forward automatically and stops automatically at the end of the Securing Program.

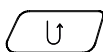

10.3 Sewing handlook quilt stitches

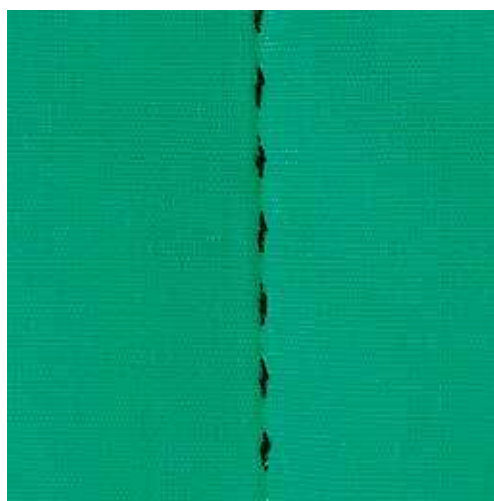

Handlook quilt stitches are suitable for all fabrics and sewing projects which should look «hand sewn». It is recommended to use a monofilament thread as upper thread and an embroidery thread as bobbin thread. The sewing speed should be moderate to prevent the monofilament from breaking. If required, the upper thread tension and the balance can be adjusted to the sewing project and the desired quilt stitch.

Prerequisite:

- The Reverse pattern foot No. 1C is attached.
- > Touch the icon «Quilt stitches».
- > Select the handlook quilt stitch No. 1328 or 1346 or 1347 or 1348.
- > If necessary, match the upper thread tension and the balance with the sewing project and the desired quilt stitch.
- > Press the foot control or push the button «Start/Stop» to start the machine.



10.4 Guiding the quilt work freely

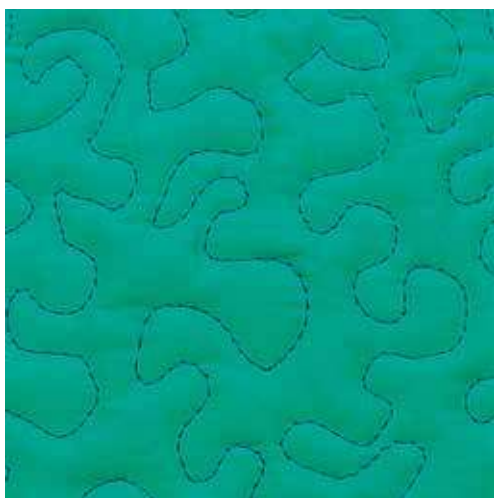

Quilt gloves with rubber fingertips (optional accessory) will help when guiding the fabric.

It is recommended to use the slide-on table and the Free Hand System. With free-motion quilting, it is of advantage to quilt from the center outwards and to guide the fabric using smooth, round movements to form the design of your choice. Free-motion quilting and darning are based on the same free-motion principles.

With stipple quilting, entire surfaces of the fabric are filled with quilt stitches. The single lines of stitching are rounded and never cross one another.

Prerequisite:

- The top layer, the batting and the backing are pinned together or basted.
- The feed dog is lowered.
- The Darning foot No. 9 (optional accessory) is attached.



- > Touch the icon «Practical stitches».
 - The Straight stitch No. 1 is selected automatically.
- > Adjust the upper thread tension and the balance to the sewing project if necessary.
- > Press the foot control or the button «Start/Stop» to start the machine.
- > Hold both hands close to the presser foot like an embroidery hoop to guide the fabric.
- > If the thread is lying on top of the fabric, slow down the movement.
- > If there are knots on the wrong side of the fabric, move the fabric more quickly.

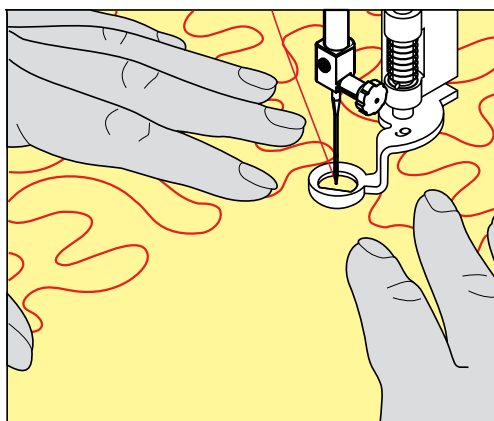

11 BERNINA Stitch Regulator (BSR)

The BERNINA Stitch regulator equalizes the stitch length which results of the free movement of the fabric while free-motion sewing - a sewing technique which grows more and more popular. When free-motion sewing with the BSR presser foot, every stitch is equally long and the stitch formation is perfectly regular.

As soon as the BSR presser foot is attached and the feed dog is lowered, the selection menu of the desired mode appears in the display of the machine. The BSR presser foot can be used with sewing straight stitch as well as zig zag.

The BSR presser foot reacts on the movement of the fabric and therefore controls the speed of the machine up to the highest possible speed. It can be said: The faster the movement of the material, the higher the speed of the machine.

If the fabric is moved too quickly, an acoustic signal sounds. The beeper can be activated or deactivated in the «BSR» display. The sound of the beeper can also be activated or deactivated in the Setup Program (see page 52).

11.1 Using the BSR mode

The BSR function can be controlled via the foot control or the button «Start/Stop».

Starting via the foot control: The foot control needs to be pressed while quilting. The machine keeps running in the BSR1 mode until the foot control is released, even if the fabric isn't moved.

If quilting is stopped in the BSR2 mode, the machine sews another stitch depending on the needle position and stops with needle position up.

Prerequisite:

- The slide-on table is attached.
- The Free Hand System lever is attached.

> Lower the feed dog.

> Select the desired BSR mode.

> Push the button «Start/Stop» or press the foot control to lower the presser foot.

> Push the button «Start/Stop» again or press the foot control again and keep pressed to start the BSR mode.

– At the BSR presser foot a red light is on.

> Move the fabric to control the speed of the machine in the BSR mode.

> Push the button «Start/Stop» again or release the foot control to stop the BSR mode.

– The BSR mode stops and the red light at the presser foot goes off.

> Touch the icon «BSR» (1) to deactivate the BSR mode and to quilt without automatic stitch length.



11.2 BSR mode 1

The BSR function can be controlled via the foot control or with the button «Start/Stop». Start the BSR mode. At the BSR presser foot a red light is on. By moving the fabric the machine accelerates. If the fabric isn't moved, securing in place is possible without pressing an additional button. When working via the foot control or when using the button «Start/Stop», the BSR mode doesn't stop automatically.

11.3 BSR mode 2

The BSR function can be controlled via the foot control or the button «Start/Stop». The machine starts only when the foot control or the button «Start/Stop» is pressed and the fabric is moved simultaneously. Without moving the fabric, the BSR2 modus stops after about 7 seconds. The red light goes off (only when working with the button «Start/Stop»). When working via the foot control, the red light doesn't go off.

11.4 BSR function with Straight stitch No. 1

This function allows free-motion quilting with straight stitch and a pre-programmed stitch length up to 4 mm. The programmed stitch length is maintained within a certain speed, independent of the fabric movement.

11.5 BSR function with Zig zag No. 2

The zig zag can be used e.g. for thread painting. The set stitch length will not be maintained when sewing the zig zag stitch, but the BSR function simplifies the application.

11.6 Sewing preparation

Attach the BSR presser foot

NOTICE The lens of the BSR presser foot is dirty

The machine doesn't recognize the BSR presser foot.

> Clean the lens with a soft, slightly damp cloth.

- > Raise the presser foot.
- > Raise the needle.
- > Switch the machine off and disconnect it from the power supply system.
- > Push the clamping lever up.



- > Remove the presser foot.
- > Insert the BSR presser foot upwards over the cone.
- > Press the clamping lever down.

- > Insert the cable of the BSR presser foot into the connection (1).



- > Switch the machine on.
 - The BSR display opens and the BSR 1 mode is activated.

Changing the presser foot sole

NOTICE The lens of the BSR presser foot is dirty.

The machine doesn't recognize the BSR presser foot.

- > Clean the lens with a soft, slightly damp cloth.

The basic stitch length is 2 mm. When sewing small shapes and stippling it is recommended to shorten the stitch length to 1 – 1.5 mm.

- > Raise the needle.
- > Raise the presser foot.
- > Switch the machine off and disconnect it from the power supply system.
- > Remove the presser foot (see page 34).
- > Press both push buttons at the BSR foot against each other.

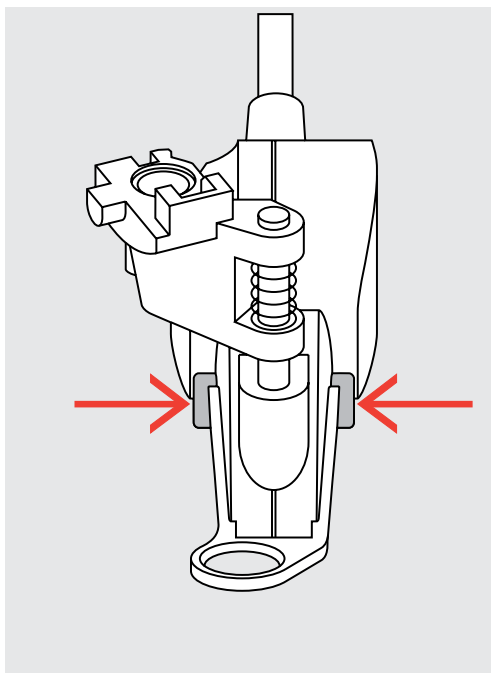

- > Pull the presser foot sole out of the guide downwards.
- > Insert the new presser foot sole into the guide and push upwards until it clicks into place.
- > Attach the BSR presser foot (see page 112).

11.7 Securing

Securing in BSR1 mode with the button «Start/Stop»

Prerequisite:

- The BSR presser foot is attached and connected with the machine.
- The BSR display is opened and the BSR1 mode is activated.

- > Lower the feed dog.
- > Lower the presser foot.
- > Press the button «Needle up/down» twice.
 - The bobbin thread is brought up.
- > Hold the upper and the bobbin thread.



- > Press the button «Start/Stop».
 - Start the BSR mode.
- > Sew 5 – 6 securing stitches.



- > Press the button «Start/Stop».
 - The BSR mode stops.
- > Cut the thread.

Securing in BSR2 mode

Prerequisite:

- BSR presser foot is attached and connected with the machine.
- The BSR display is open and the BSR2 mode is activated.

- > Lower the presser foot.
- > Press the button «Securing».
- > Press the foot control or the button «Start/Stop».



By moving the fabric some short securing stitches are sewn, then the programmed stitch length is activated and the securing function is deactivated automatically.

12 Attachment

12.1 Maintenance and cleaning

Cleaning the display

- > Clean the display with a soft damp cloth.

Cleaning the feed dog

CAUTION Electronically driven components.

Risk of injury near the needle and the hook.

- > Switch the machine off and disconnect it from the power supply system.

Remove the thread remnants under the stitch plate regularly.

- > Remove the presser foot and the needle.
- > Push the button «Feed dog up/down» (1) to lower the feed dog.



- > Remove the stitch plate.
- > Clean the feed dog with the brush.

Lubricating the machine

CAUTION Electronically driven components.

Risk of injury near the needle and the hook.

- > Switch the machine off and disconnect it from the power supply system.

Prerequisite:

- The stitch plate is removed.
- > Fill the oil depot with 1 drop of the supplied BERNINA oil.

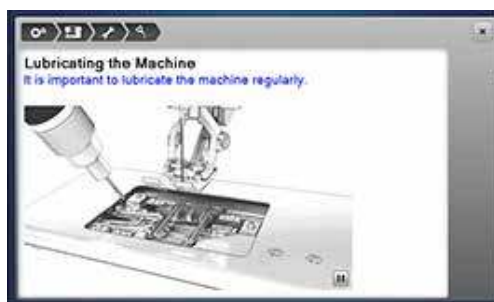

Cleaning the hook

CAUTION Electronically driven components.

Risk of injury near the needle and the hook.

- > Switch the machine off and disconnect it from the power supply system.

- > Open the bobbin cover.
- > Remove the bobbin case.
- > Press the release lever to the left.



- > Flap down the fastening bracket along with the black hook race cover.
- > Remove the hook.

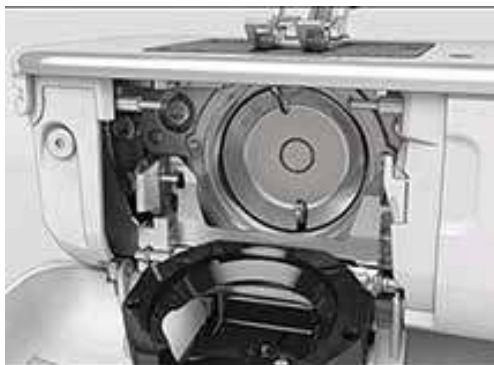

- > Clean the hook race with a brush; do not use any pointed objects.
- > Hold the hook at the pin in the center with two fingers.
- > Lead the hook, lower edge ahead, angular top-down behind the hook race cover.
- > Position the hook with the two lugs meeting the openings in the hook, the colored mark on the hook driver should be visible through the hole in the hook.
- > Insert the hook.
 - The hook is magnetic and therefore fastened to the correct position.
- > Close the hook race cover and the fastening bracket until the release bracket engages.
- > As a check, turn the handwheel.
- > Insert the bobbin case.

Lubricating the hook

⚠ CAUTION Electronically driven components.

Risk of injury near the needle and the hook.

> Switch the machine off and disconnect it from the power supply system.

> The bobbin case is removed.

> Push the release lever to the left.



> Flap down the fastening bracket along with the black hook race cover.

> Remove the hook.



> Fill as much BERNINA-oil into both oil depots so that the felts are damp and make sure that the surface of the hook sleeve (marked in red) remains free of oil.



> Hold the hook at the pin in the center with two fingers.

> Lead the hook, lower edge ahead, angular top-down behind the hook race cover.

> Position the hook with the two lugs meeting the openings in the hook, the colored mark on the hook driver should be visible through the hole in the hook.

- > Insert the hook.
 - The hook is magnetic and therefore fastened to the correct position.
- > Close the hook race cover and the fastening bracket until the release bracket engages.
- > As a check, turn the handwheel.
- > Insert the bobbin case.







12.2 Troubleshooting



Malfunction	Cause	Repair
Uneven stitch formation	Upper thread too tight or too loose.	> Adjust the upper thread tension.
	Needle blunt or bent.	> Change the needle and make sure the a new BERNINA quality needle is used.
	Poor quality needle.	> Use a new BERNINA quality needle.
	Poor quality thread.	> Use quality thread.
	Incorrect needle/thread combination.	> Match the needle with the thread size.
	Incorrectly threaded.	> Rethread.
	The fabric has been pulled.	> Feed the fabric evenly.
Uneven stitch formation	The incorrect bobbin cased is used.	> Use the supplied bobbin case with triangles.
		
Skipped stitches	Incorrect needle.	> Use needles of the needle system 130/705H.
	Needle blunt or bent.	> Change the needle.
	Poor quality needle.	> Use a new BERNINA quality needle.
	The needle is incorrectly inserted.	> Insert the needle into the needle holder with the flat side to the back as far it will go and tighten the screw.
	Incorrect needle point.	> Match the needle point with the textile structure of the sewing project.
Faulty stitching	Thread remnants between the thread tension discs.	> Pull thin folded fabric (don't use fabric edges) through the thread discs several times.
	Incorrectly threaded.	> Rethread.
	Thread remnants below the bobbin case spring.	> Remove the thread remnants below the spring.



Malfunction	Cause	Repair
Upper thread breaks	Incorrect needle/thread combination.	> Match the needle with the thread size.
	Upper thread is too tight.	> Reduce the upper thread tension.
	Incorrectly threaded.	> Rethread.
	Poor quality thread.	> Use quality thread.
	The stitch plate or the hook tip is damaged.	> Contact your BERNINA specialized dealer to eliminate the damages. > Change the stitch plate.
	The thread is caught in the area of the thread take-up lever. 	> Remove the screw (1) at the cover with the Torx Allen wrench. > Pull the cover carefully to the front. > Flip the cover slightly upwards to remove it. > Remove the thread remnants. > Attach the cover and tighten the screw.
Lower thread breaks	The bobbin case is damaged.	> Replace the bobbin case.
	The stitch hole in the stitch plate is damaged.	> Contact your BERNINA specialized dealer to eliminate the damage. > Change the stitch plate.
	Needle blunt or bent.	> Change the needle.
Needle breaks	The needle is incorrectly inserted.	> Insert the needle with the flat side to the back as far it will go and tighten the screw.
	The fabric has been pulled.	> Feed the fabric evenly.
	Thick fabric has been pushed.	> Use the appropriate presser foot, i. e. the Jeans foot No. 8, for thick material. > Use the height compensation tool for thick seams.
	Knotted thread.	> Use quality thread.
Display is inactive	Incorrect calibrating data.	> Switch the machine off. > Switch the machine on and at the same time push the button «Needle left/right» and keep pressed. > Calibrate the display again.
	The eco-function is active.	> Touch the icon «eco».
Stitch width not adjustable	The selected needle and stitch plate cannot be used in combination.	> Change the needle. > Change the stitch plate.

Malfunction	Cause	Repair
Sewing speed too low	Unfavorable room temperature.	> Put the machine into a room with room temperature 1 hour before starting to sew.
	Settings in the Setup Program.	> Program the sewing speed in the Setup Program. > Adjust the sewing speed via the slide.
The machine doesn't start	Unfavorable room temperature.	> Put the machine into a room with room temperature 1 hour before starting to sew. > Connect the machine to the power supply system and switch it on.
	The machine is damaged.	> Contact your BERNINA specialized dealer.
The light of the «Start-/Stop» button doesn't light up	Light is defect.	> Contact your BERNINA specialized dealer.
Neither the sewing light nor the light on the free arm lights up	Settings in the Setup Program.	> Im Setup Program einschalten.
	The sewing light is defect.	> Contact your BERNINA specialized dealer.
Upper thread indicator doesn't react	Settings in the Setup Program.	> Activate it in the Setup Program.
	The upper thread indicator is defect.	> Contact your BERNINA specialized dealer.
Error during software update	USB stick is not recognized.	> Use a BERNINA USB Stick.
	The update process is blocked and the hourglass on the display is inactive.	> Remove the USB Stick. > Switch the machine off. > Switch the machine on. > Follow the instruction on the display.
	Date of the software update cannot be found.	> Unzip the compressed ZIP file. > Save data for the software update directly on the data medium and not in a file on the USB Stick.

12.3 Error messages

Message on the display	Cause	Repair
	Stitch number unknown.	> Check what you have entered and enter a new number.
	Selection of the stitch pattern not possible in the combi mode.	> Combine any other stitch patterns.
	The feed dog is not lowered.	> Push the button «Feed god up/down» to lower the feed dog.
	The selected needle and stitch plate cannot be used in combination.	> Exchange the needle. > Exchange the stitch plate.
	The needle is not at its top end.	> Adjust the needle position via the hand wheel.
	The upper thread is used up.	> Rethread.
	The upper thread has broken.	> Rethread.
	The main motor isn't running.	> Clean the hook. > Remove the hook and make sure that there are no broken needle points on the magnetic hook back.

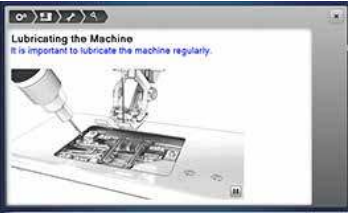
Message on the display	Cause	Repair
	Incorrect presser foot for the BERNINA Dual Transport.	> Attach a presser foot with the labeling «D».
	The fabric under the presser foot is too thick.	> Reduce the fabric thickness.
Too less free capacity on the BERNINA USB stick (optional accessory).	Not enough free capacity on the BERNINA USB stick (optional accessory).	> Make sure that the BERNINA USB Stick (optional accessory) is used. > Delete data on the BERNINA USB Stick (optional accessory).
No personal data on the BERNINA USB stick (optional accessory).	No personal data for recovery available on the BERNINA USB stick (optional accessory).	> Make sure that the data and settings have been saved on the BERNINA USB Stick.
The recovery of personal data has failed.	The software update has been successful but the personal data couldn't be recovered.	> Make sure that the data and settings have been saved on the BERNINA USB Stick. > Transfer the saved data to the machine.
No BERNINA USB stick is inserted. Make sure that during the complete automatic update always the same BERNINA USB stick remains inserted.	The BERNINA USB stick (optional accessory) is not inserted.	> Use a BERNINA USB stick (optional accessory) providing enough free capacity.
The update of the software has failed.	The latest software version cannot be found on the USB stick.	> Make sure that the compressed ZIP file has been unzipped for the software update. > Make sure that the data for the software update are saved directly on the data medium and not in a file on the USB Stick. > Update the software.

Message on the display	Cause	Repair
 	<p>The machine needs cleaning/ lubricating.</p>	<ul style="list-style-type: none"> > Clean the machine. > Lubricate the machine.
<p>It is time for the regular maintenance. Please contact your specialized BERNINA dealer to make an appointment.</p>	<p>The machine needs maintenance. The message appears after the programmed service interval has expired.</p> <p>Important Information: Having your machine cleaned and serviced properly at the appropriate times ensures its proper functioning and a long service life. Failure to do so may adversely affect service life and limit the guarantee. The charge for servicing is nationally regulated – consult your dealer or servicing shop for more details.</p>	<ul style="list-style-type: none"> > Contact your BERNINA specialized dealer. > Delete the message temporarily by touching the icon «ESC» . <p>Having cleared the message three times, the message will appear as recently as the next service interval has been completed.</p>

12.4 Storage and disposal

Storing the machine

It is recommended to store the machine in the original packaging. If the machine is stored in a cold room, place it in a warm room one hour before use.

- > Switch the machine off and disconnect it from the power supply system.
- > Don't store the machine outdoor.
- > Protect the machine against climatic influences.

Dispose of the machine

BERNINA International AG is committed to the protection of the environment. We strive to minimize the environmental impact of our products by continuously improving product design and our technology of manufacturing.

When the machine won't be used anymore, dispose this product in an environmentally responsible way according to the national directive. Do not throw away this product with your household waste. When in doubt, bring the machine to your local specialized BERNINA dealer.

- > Clean the machine.
- > Sort the components by their materials and dispose of them according to the local laws and regulations.

12.5 Technical data

Term	Value	Measurement unit
Maximum fabric thickness	12.5	mm
Sewing light	30	LED
Maximum sewing speed	1000	spm/rpm
Measurements without the spool pin	522/214/358	mm
Weight	14	kg
Energy consumption	140	Watt
Input voltage	100-240	Volt
Protection class (Electrical engineering)	II	

12.6 Overview Stitch patterns

Practical stitches





























1	2	3	4	5	6	7	8	9	10	11
12	13	14	15	16	17	18	19	20	22	23
24	25	26	29	30	32	33				

Buttonholes





















51	52	53	54	57	59	63	69	60	61	62

Decorative stitches





























Florals

101	102	103	104	107	108	110	111	112	113	114
										
115	117	119	120	121	122	123	124	125	128	129
										
134	136	137	143	146	147	152				
										

Cross stitches

301	302	303	304	305	306	307	308	309	311	314
										
323	324	325	326	371	372	373	374	375	376	
										

Satin stitches

401	402	405	406	407	408	412	413	414	415	416
										
417	419	422	424	425	426	428	429	430	431	437
										
439	450	457	461	464	471	473				
										

Ornamental stitches

601	602	603	604	605	606	607	610	611	612	613
614	615	616	627	630	631	633	635	639	640	641
642	643	644	645	648	649	651	653	655	656	661
676	677	684	685							

Heirloom stitches

701	702	705	706	708	709	710	711	712	713	714
717	719	720	721	722	723	724	725	726	728	730
731	732	738	740	741	742	743	746	747	748	749
750	751	772	775	777	779					

Novelty

903	904	906	907	908	911	913	914	916	919	920

921	925	929	930	934	935	938	939	940	942	947

Quilt stitches

1324	1325	1327	1328	1329	1330	1331	1332	1333	1334	1336
1339	1346	1347	1348	1352	1353	1354	1355	1356	1357	1358
	$\frac{6}{\text{Inch}}$ $\frac{2.4}{\text{cm}}$	$\frac{8}{\text{Inch}}$ $\frac{3.2}{\text{cm}}$	$\frac{10}{\text{Inch}}$ $\frac{4}{\text{cm}}$							
1359										

A	
Activating the audio signals	52
Activating the upper thread indicator	51
Adjusting Needle stop up/down (permanent)	36
Adjusting the brightness of the display	53
Adjusting the presser foot pressure	35
Adjusting the presser position via the lever of the Free Hand System	34
Adjusting the sewing light	53
Adjusting the upper thread tension	48
Alphabets	94
Attaching the BSR presser foot	112
Attaching the Free Hand System	30
B	
Back to basic settings	54
BERNINA Dual Feed	61
Buttonholes	96
C	
Calibrating the Buttonhole foot No. 3A	55
Calibrating the display	53
Calling up the Creative Consultant	47
Calling up the Help	47
Calling up the Tutorial	47
Changing the needle	37
Changing the presser foot	34
Changing the stitch plate	38
Checking the Software Version	58
Child safety lock	73
Cleaning the feed dog	115
Cleaning the hook	116
Cleaning the machine	57
Combi mode	68
Connecting the foot control	29
Cord	99
D	
Decorative stitches	89
Dispose of the machine	125
E	
Error messages	122
I	
Included accessories	19
Introduction	14
K	
Key to signs	14
L	
Lubricating the hook	117
Lubricating the machine	57, 115
M	
Maintenance and Cleaning	115
N	
Needle, Thread, Fabric	24
Needle/thread combination	26
O	
Overview Stitch patterns	126
P	
Pintucks	91
Positioning the spool disc	32
Power save mode	73
Practical stitches	74
Programming the securing stitches	48
Q	
Quilting	108
R	
Raising/Lowering the needle	31
Registering details of the dealer	58
Regulating the sewing speed	62

S

Safety instructions	11
Saving Service data	59
Selecting a language	52
Selecting a stitch pattern	60
Selecting personal settings	51
Sewing a test sample	101
Storage and disposal	125, 126

T

Threading preparation	39
Threading the bobbin thread	44
Threading the double needle	42
Threading the triple needle	43
Threading the upper thread	39
Troubleshooting	119

U

Updating the software	56
Using a spool net	32
Using eco mode	73

W

Winding the bobbin thread	43
---------------------------	----

