



WPS Decking Installation Guide

www.wpshandrails.com

 **wps** | handrails
Balustrades & Composite Decking

WPS Decking Installation Guide

These installation guidelines will direct you through the process of installing our composite decking products. Most installers will find this process similar to the installation of a wood deck. However, there may be areas that differ from what you are used to.

These installation methods are recommended by WPS, but they may not cover every installation scenario you may encounter. Since each installation is unique in its performance requirements, the ultimate installation method used is the sole responsibility of the installer. WPS recommends that all designs be reviewed by a licensed architect, engineer or local building official before installation. Make sure your plans meet local building codes before you begin the installation.

Tools Required

WPS composite decking can be installed with a minimum number of readily available tools. However, many other tools are available that can provide even greater efficiency and ease of installation. All tools should be used per applicable manufacturers' instructions. Some of the basic tool requirements:

- Cordless Driver • Carpenter Square
- Chalk Line • Spacing Tools
- Tape Measure • Circular Saw
- Jig Saw • Safety Glasses

Use the jigsaw to cut around obstructions such as posts. A power mitre saw can also be very helpful during installation.

For a power mitre or compound power mitre saw a fine finish alternate top bevel blade is also recommended. When working with composite products be sure to wear proper clothing and safety equipment. Safety glasses should be used during the entire installation process.

WPS does not recommend the use of rubber or vinyl products (welcome mats, planters, etc.) on our deck planks. A reaction can occur that causes discoloration of the decking under the rubber/vinyl product. This is a common caution for vinyl decking products.

Read this section before you start!

For most current guidance care and cleaning, technical information and more, visit www.wpshandrails.com/innodek.

Static Electricity – Static build-up is a natural occurring phenomenon that can occur with many plastic products. It could occur with our products under the right environmental conditions.

Cantilevering – Our decking can be cantilevered a maximum of 13mm.

Colour and Grain Patterns – Our wood-plastic composite deck boards are designed to mimic the look of real wood, and like real wood, there will be a slight difference in colour and grain pattern from board to board. This is intentional and part of the manufacturing process, giving our wood-plastic composite decking the most realistic and wood-like appearance possible. This variation is purely aesthetic and does not or will not affect the performance of the product. Our deck boards are designed to naturally weather over time and the surface pattern will weather to a consistent colour. Most of the weathering process will be complete within the first year of the deck's life.

Note – Our composite boards are NOT intended for use as columns, support posts, beams, joist stringers or other primary load-bearing members. Our boards must be supported by a code-compliant substructure. While our composite boards are great for deck re-planking (removing old deck surface planks and installing replacement composite boards on code-compliant substructure), Our planks CANNOT be installed on top of existing deck planks.

Extreme Heat Warning

Be aware of excessive heat on the surface of our composite boards from external sources such as but not limited to fire or reflection of sunlight from energy efficient window products. Low-impassivity (Low-E) glass can potentially harm composite deck boards. Low-E glass is designed to prevent passive heat gain within a structure and can cause unusual heat build-up on exterior surfaces. This extreme elevation of surface temperatures, which exceeds that of normal exposure, can possibly cause our products to melt, sag, warp, discolour, increase expansion/contraction, and accelerate weathering. Current or potential customers that have concerns about possible damage by Low-E glass should contact the manufacturer of the product which contains Low-E glass for a solution to reduce or eliminate the effects of reflected sunlight.

Excessive Construction Debris

It is important during construction, the deck's surface stay clear from excessive build-up of dirt, sand, and dust from tile, concrete, landscape blocks, or any other masonry products. If these materials are not removed immediately, the deck surface will become difficult to clean and foot traffic can potentially damage the deck's surface finish.

Calculating Material Requirements

To determine how much decking material you will need, start by calculating the square footage of your deck surface by multiplying length by width. When calculating the amount of decking you will need, it is recommended that you add between 5-10% to the total for a scrap factor.

Expansion and Contraction

Composite deck planks will experience expansion and contraction with changes in temperature. Expansion and contraction are most significant where extreme temperature changes occur. Fastening the deck planks according to the gapping requirements noted in the following table accommodates for this movement. Changes in length are most significant during the installation process, and should be accounted for if working in extreme temperatures. A good example would be cutting your planks during a hot afternoon, letting them sit outside overnight in the cool air and then installing them the next morning. Chances are, you will notice a certain amount of contraction. The best way to minimize this problem is to fasten your planks as soon after cutting as possible.

Fascia installation recommendations

Fascia utilised around the perimeter of a deck must be gapped with the same requirements as decking to allow for air flow and expansion/contraction of the fascia.

Tips:

1. 250mm rim joists allow for an easier and more aesthetically pleasing installation.
2. Mitre cuts at butt joints and corners allow for a more aesthetically pleasing installation.

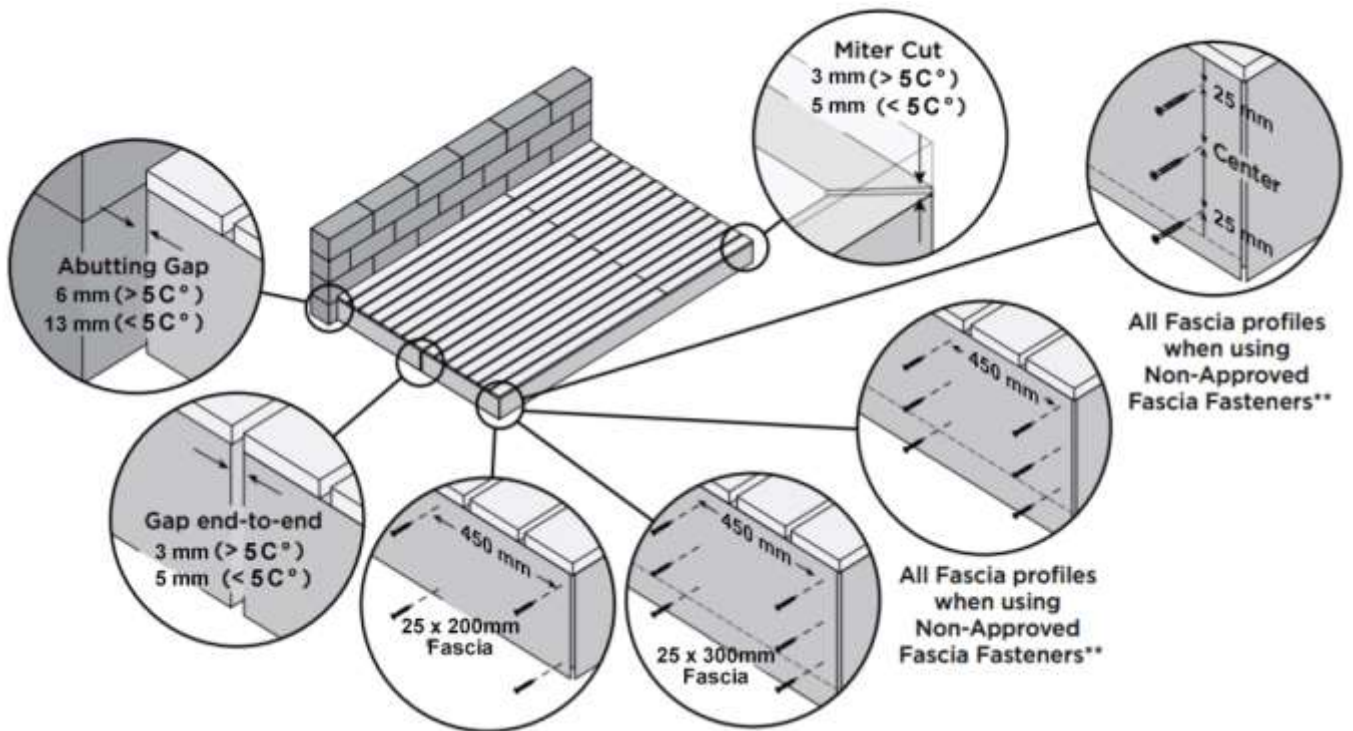

NOTE: When using pneumatic or battery-operated equipment, adjust the pressure so that you only shoot the head of the screw to be flush with the board's cap. DO NOT shoot the fastener head completely through the cap. The fascia size is only for example, there are many types of fascia for the decking, please fix it according to the dealer's or manufacturer's guide.

Low-E glass reflects more sunlight, and it has been observed that the extra reflectivity combined with any concavity in the glass can act like that of a concave mirror, concentrating sunlight onto outdoor objects, including that of decking and railing. This can result in an extreme amount of heat concentrated on areas of the decking surface, which, in turn, can sometimes char the decking surface or cause the decking to slightly bow.

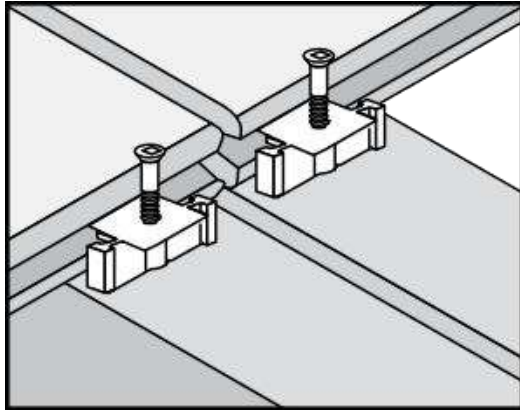

For butt joints, where boards meet over a single joist, add a 50mm x 100mm "nailer" board at the butt joint. This allows screw-in at 90 degrees and allows fasteners to be used at end of each board.

Dock Application

Composite decking contains no materials that will harm marine life and is safe for the environment. As long as dock is in intermittent contact with water, i.e., splashing and not in continuous direct contact with water, the durability of our decking should not be affected.

For docks, a 10mm width-to-width gap between boards is recommended to allow for increased drainage due to increased contact with water. In addition, stainless steel fasteners should be used. If there is sufficient contact between the dock and gasoline, grounding of the dock is also recommended.

Special Patterns

When planning a unique pattern, you will need to adjust the framing to support the surface pattern. Many decks are designed to take advantage of angles, as shown below.

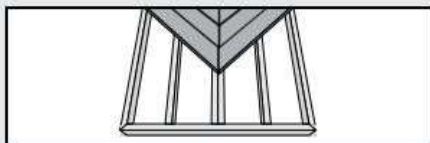

Herringbone Pattern

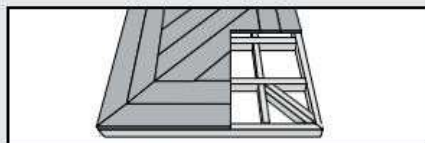

Picture Frame

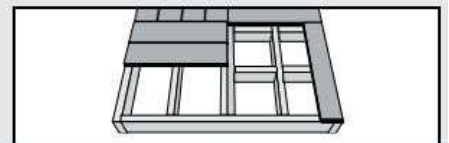

Tile

Rooftop and sleeper deck systems - Pressure treated framing

A sleeper system is a substructure between a solid surface and decking. Drainage, access, and airflow are critical. Water must be able to flow through and away from the deck. For repairs and removal of debris, joist system access may be necessary.

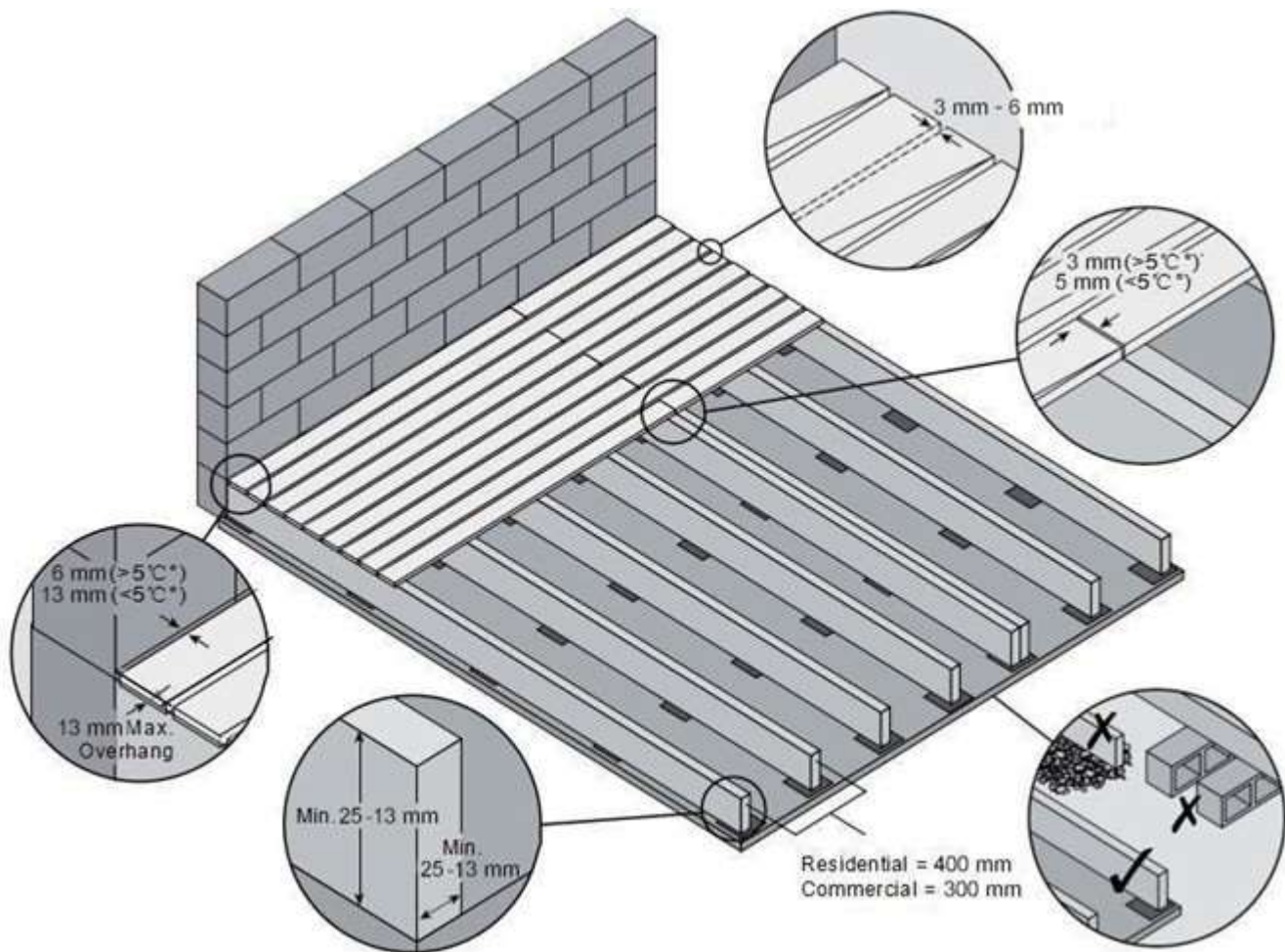

- » It is recommended that building-code-approved structural material be used as the supports.
- » This system should not be allowed to float; it must be attached in a manner that secures the framing/system.
- » The sleeper system must be level and have no uneven undulations. Any uneven areas of the substructure will transfer to the decking, resulting in uneven decking.

» Composite deck boards, when used with a sleeper system, must be supported below their entire length. If using in a roofing application, the supports must run the direction of the pitch of the roof to facilitate proper drainage. Sleeper should be placed perpendicular to the deck board orientation.

» For commercial applications, consult a local building code official for specific requirements.

» If installing decking at an angle, decrease spans 100mm for each of the above. 300mm for residential and 200 mm for commercial.

Metal framing requirements and gapping

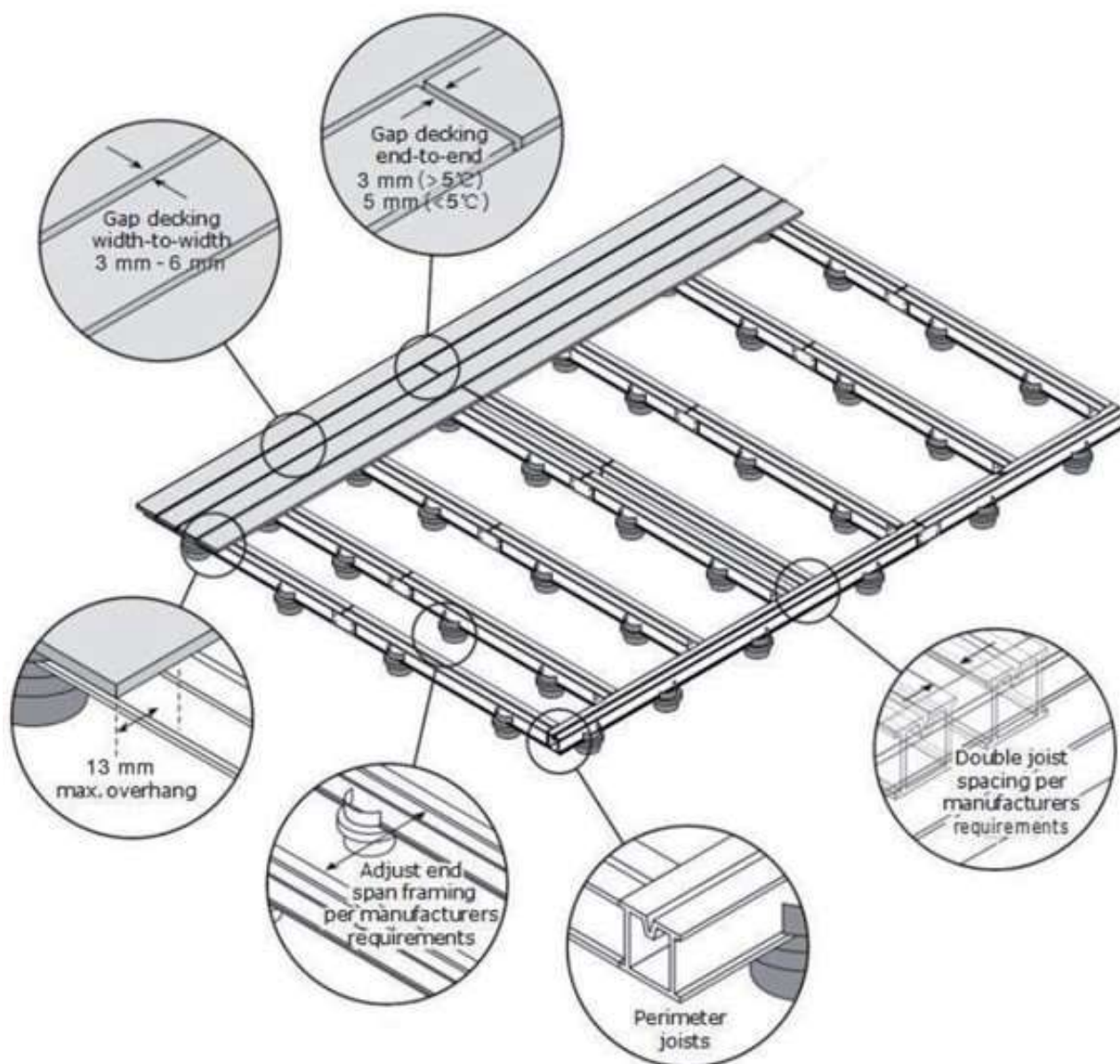

NOTES:

- » When using an aluminium framing system or other type of metal for sleeper systems, follow manufacturer's instructions for proper installation.
- » Depending on type of structure being used, different types of fasteners must be used for attachment.
- » When using screws to attach decking to framing, use two screws per every joist.

Joist Spacing

Joist Spacing	300mm	350mm	400mm
Decking Type	Square hollow decking	Circle hollow decking	Solid decking

Gapping and overhang

You must gap composite decking, both end-to-end and width-to-width. Gapping is necessary for drainage and the slight thermal expansion and contraction of the decking boards. Gapping also allows for shrinkage of the wood joist system.

- » ALWAYS follow our recommended gapping guidelines.
- » Maximum allowable perpendicular overhang for all our decking is 13mm.
- » All decks require air circulation to keep them dry and looking good. To improve air flow, leave openings under the decking or increase gapping to 10mm.



END-TO-END/END-TO-WIDTH AND ABUTTING GAP		
	End-to-End/ End-to-Width	Abutting Gap
Above 5°C*	3 mm	6 mm
Below 5°C*	5 mm	13 mm

When you use the recommended hidden fasteners, the placement of the hidden fastener establishes the designated gap size. When installing fascia, gapping rules must apply.

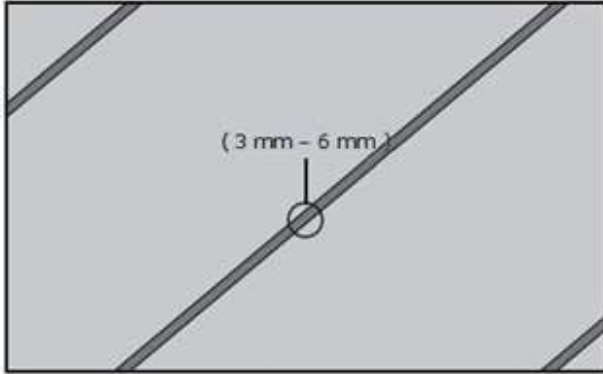

Width-to-Width

The minimum required width-to-width gapping is 3 mm, this is to allow for both hot and cold weather installations, fixings to provide a 6mm gap are also available. No gapping should ever exceed 13mm.

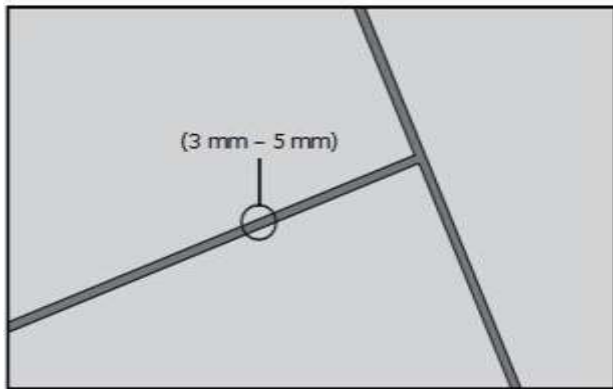

End-to-End/End-to-Width

Gap composite decking end-to-end, based upon the temperature at installation.

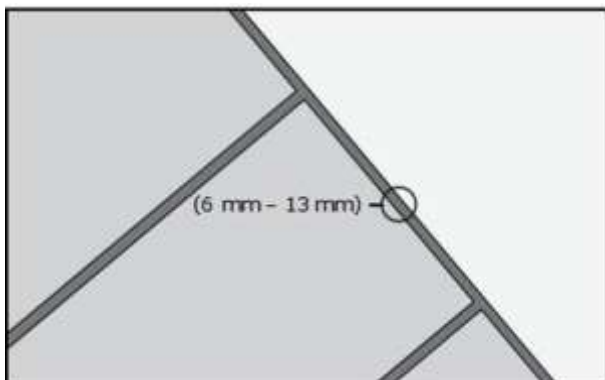

Abutting Solid Objects

When decking is abutting a wall, you must also gap it 6–13 mm depending on the temperature at installation

Install Steps Option A - ("T" Clip system with fascia)

"T" Clip Options

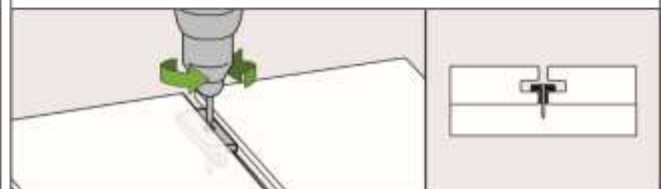
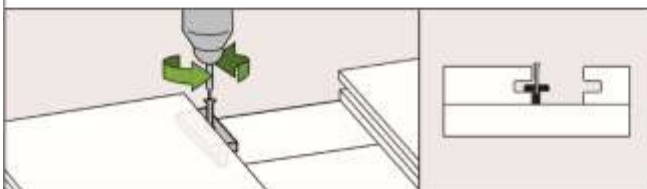
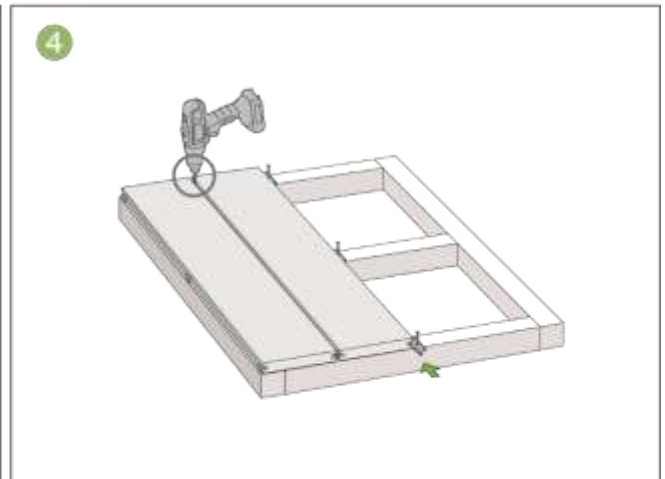
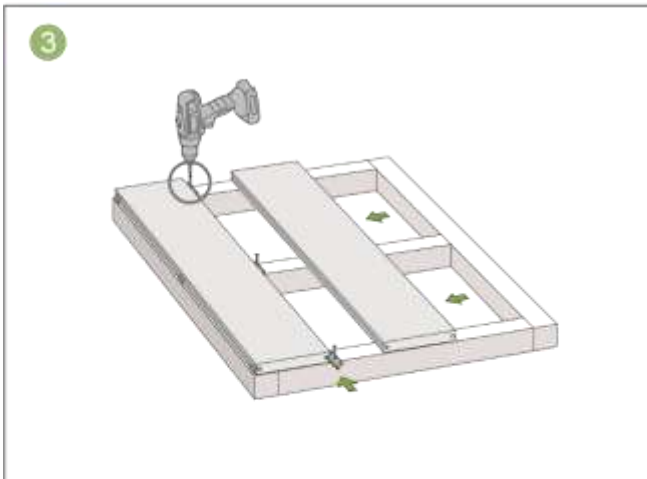
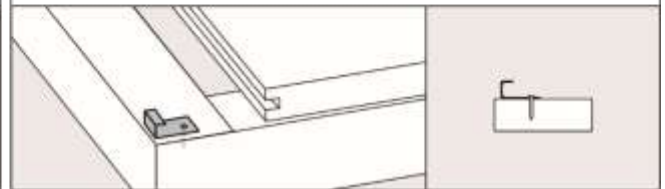
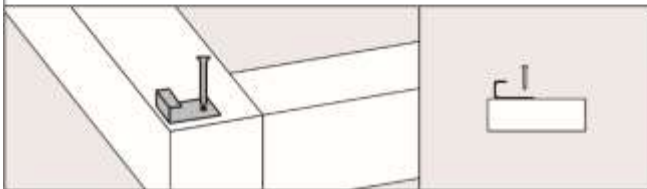
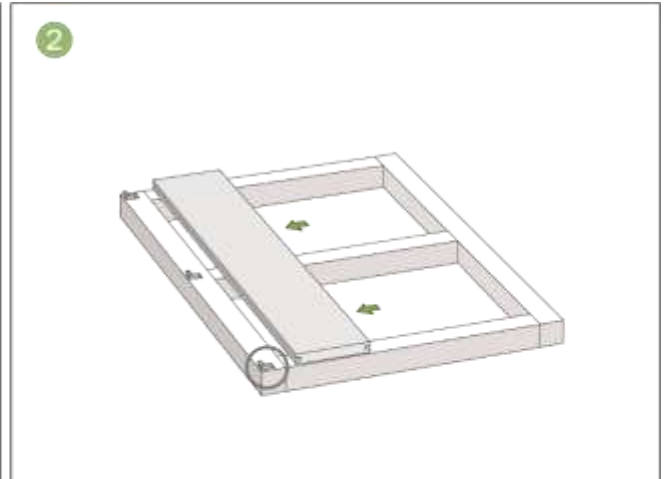
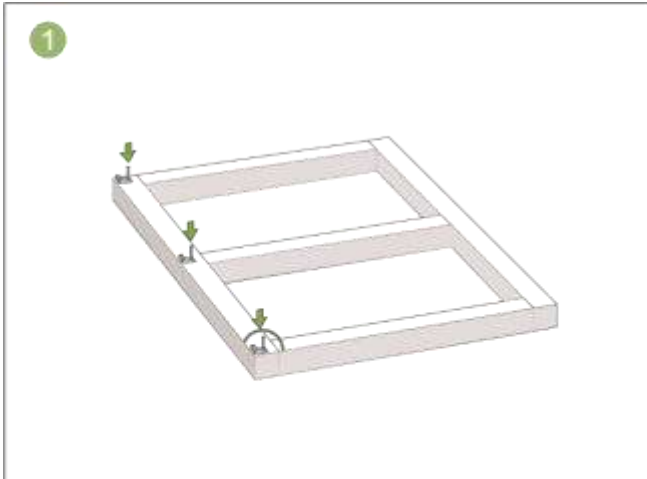
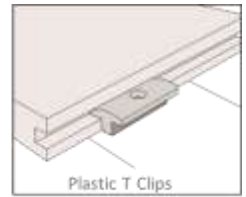

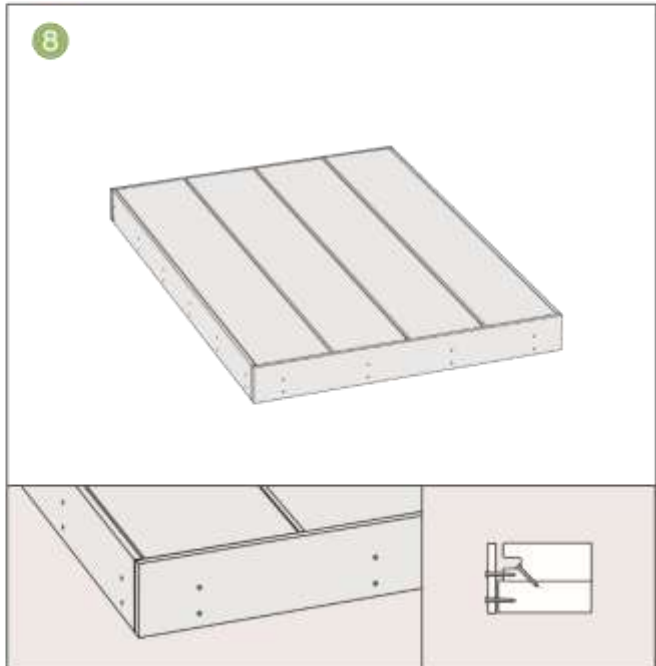
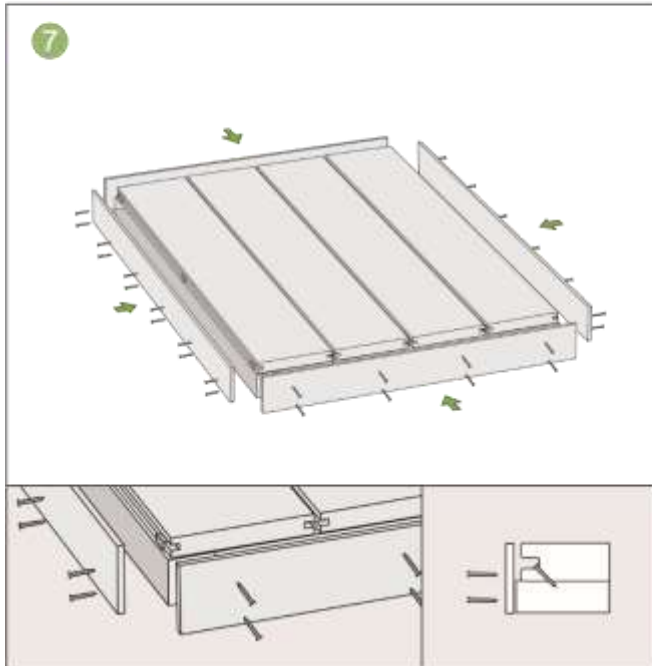
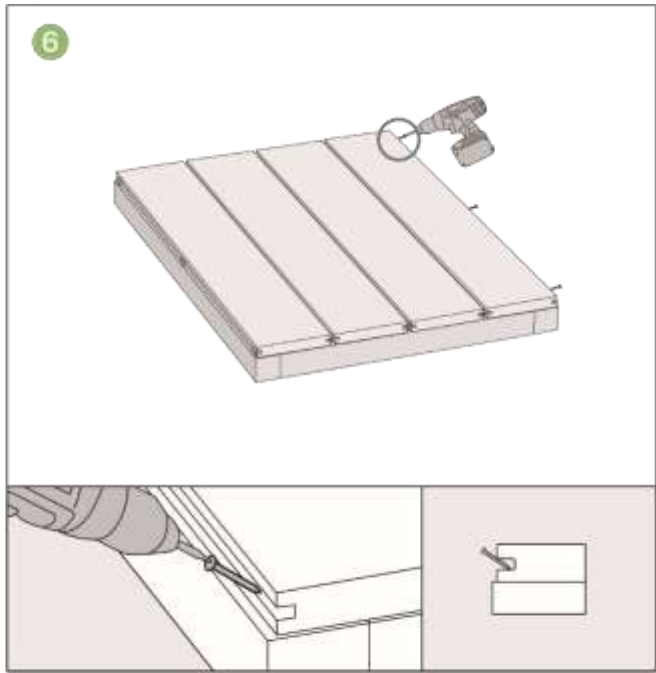
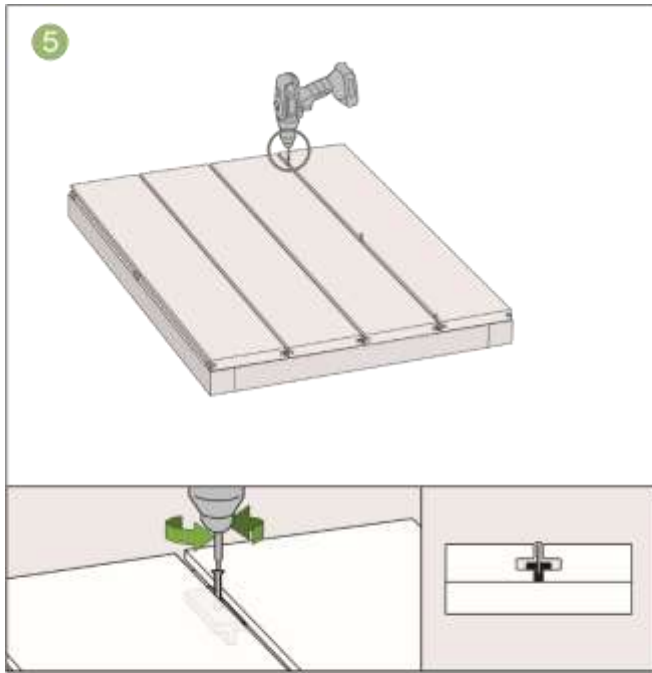

Install Steps Option B - ("T" Clip system with edge board)

"T" Clip Options

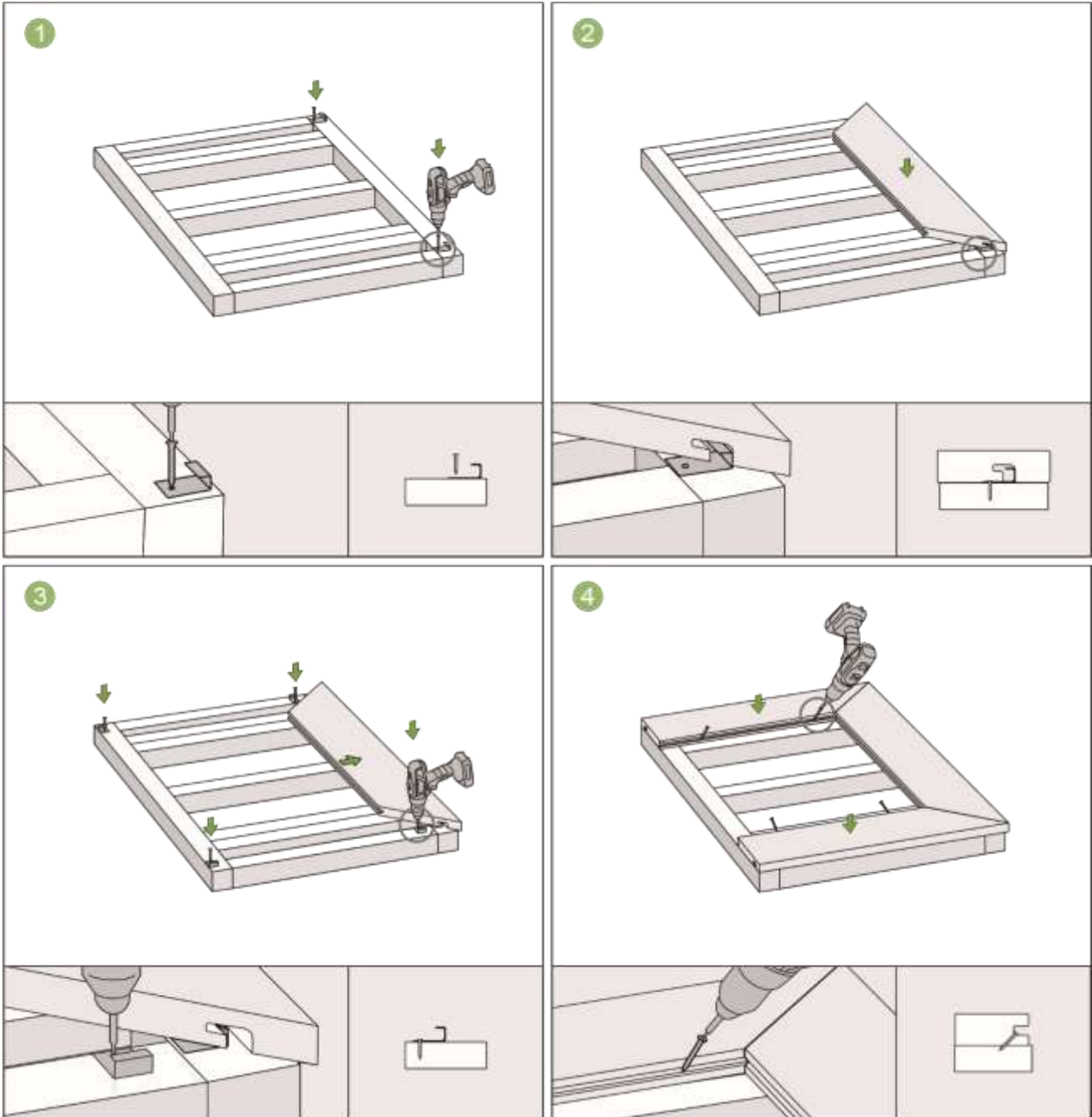
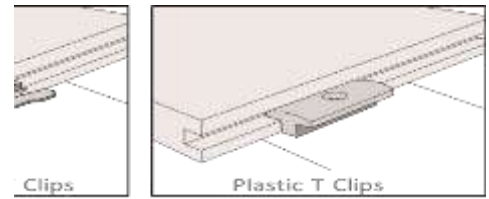

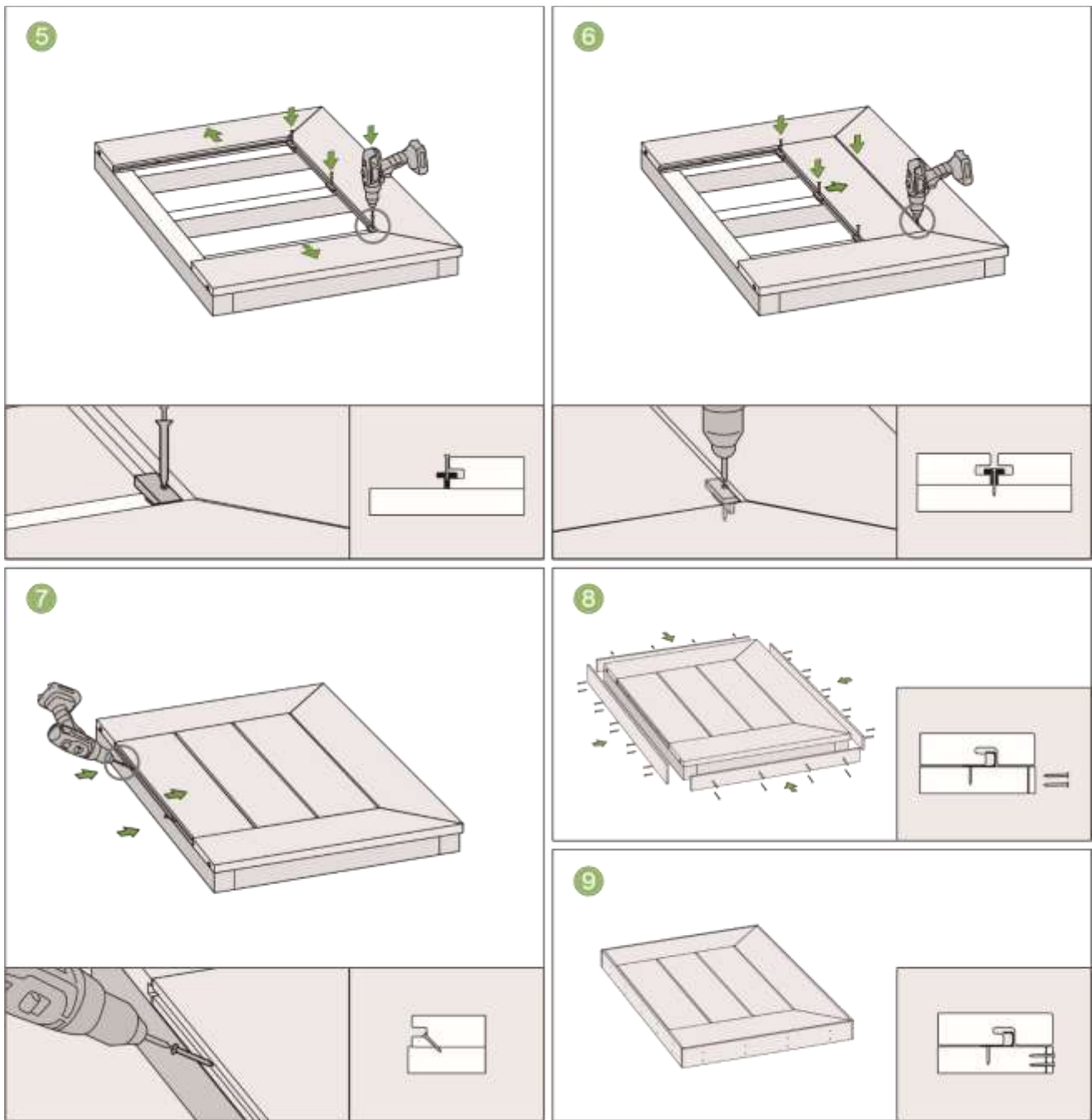

Install Steps Option C - ("π" Clip system with fascia)

"π" Clip Options

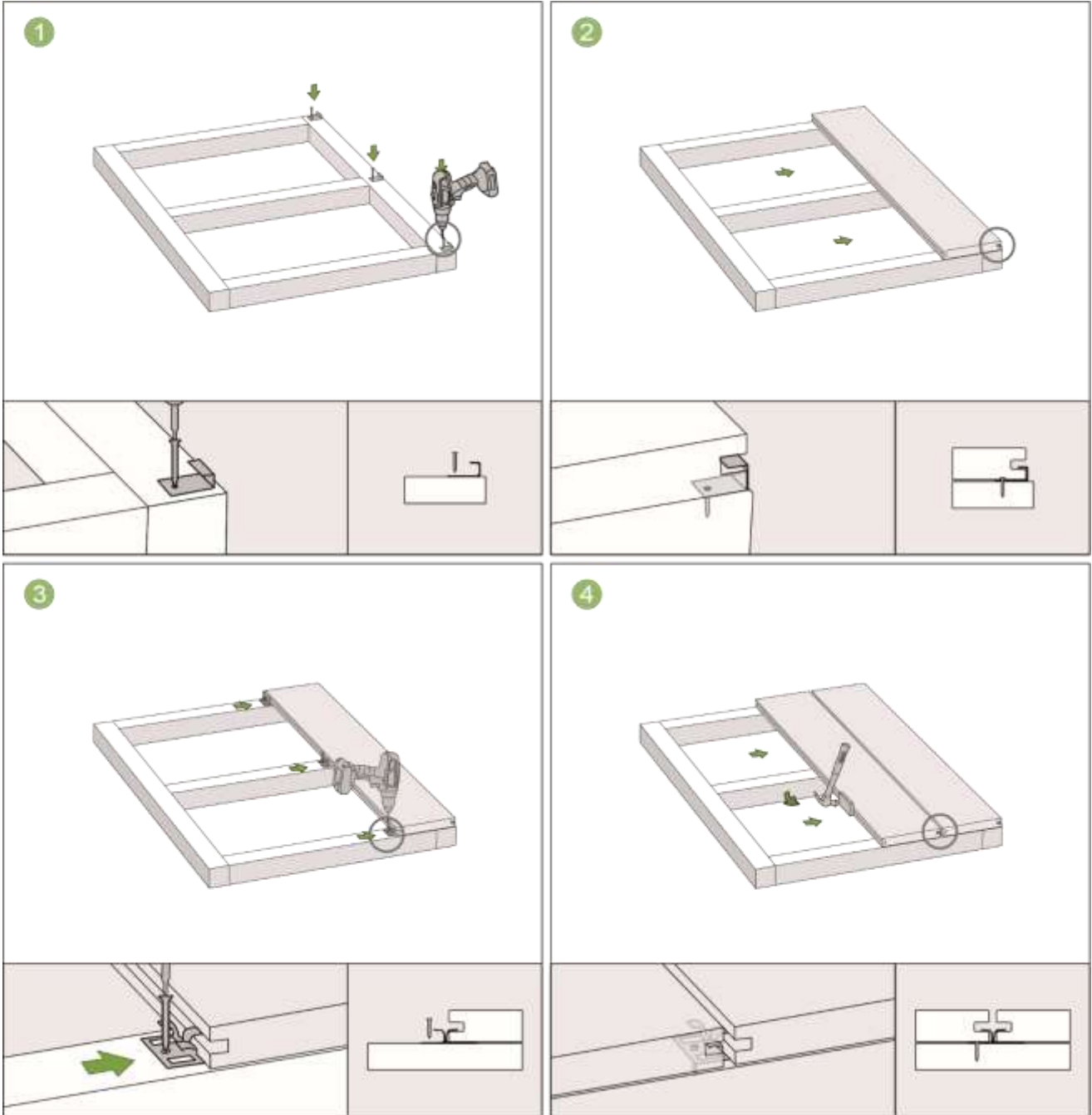
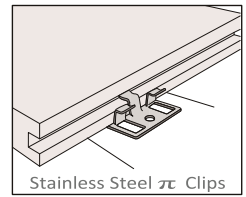

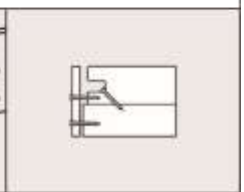
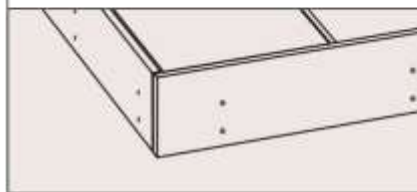
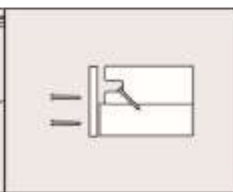
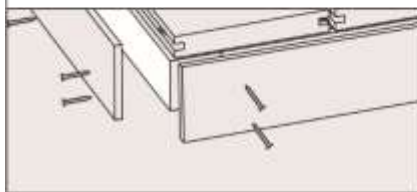
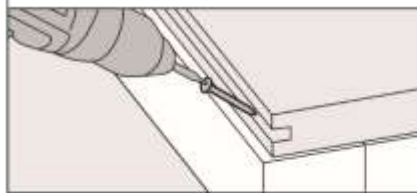
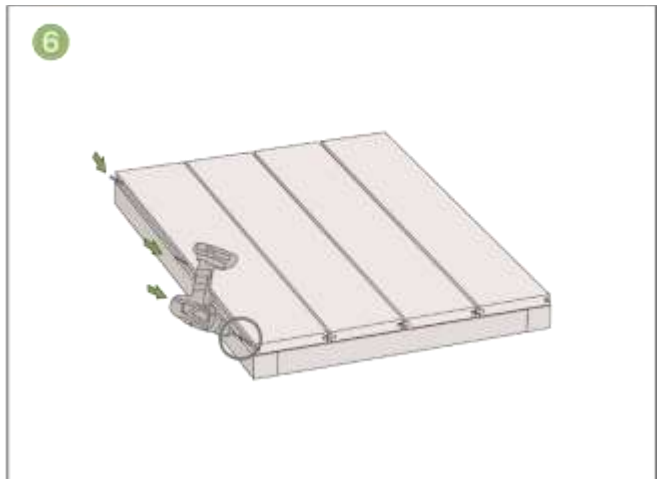
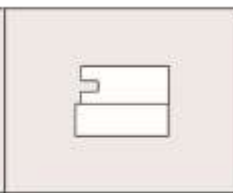
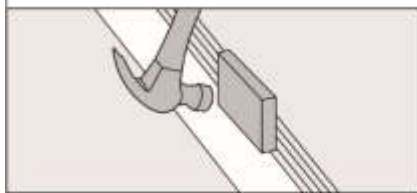

Install Steps Option D - (“π” Clip system with edge board)

“π” Clip Options

