

WOK 'N' ROLL

**INFERNO20 WOK BURNER
USER MANUAL**

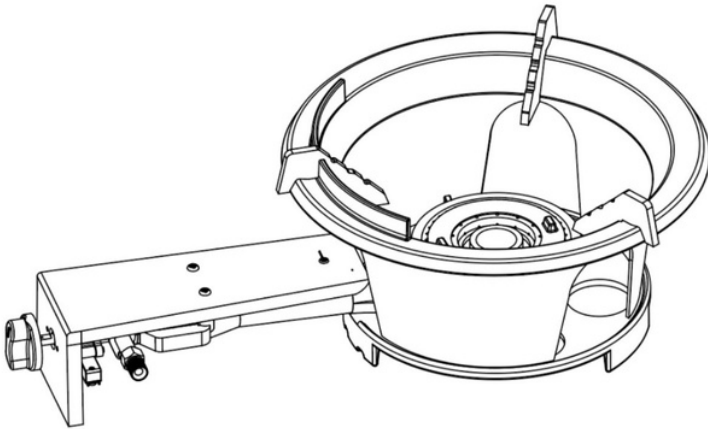

KEEP ME!

WOK 'N' ROLL

CONTENTS

- 4** THANK YOU FOR YOUR SUPPORT
- 4** CONTACT INFORMATION
- 5** PACKAGE CONTENTS
- 5** BEFORE USE
- 6** IMPORTANT SAFETY INFORMATION
- 7** POSITIONING OF APPLIANCE
- 10** GAS CONNECTION
- 10** GAS CYLINDER
- 11** OPERATION
- 11** 5 THINGS YOU NEED TO KNOW BEFORE YOU START WOK COOKING
 - 12** COOKING SETUP
 - 14** WOK SEASONING
 - 15** WOK CLEANING AND CARE
 - 15** PANTRY MUST HAVES
 - 18** FOOD PREPARATION

WOK 'N' ROLL

19 REGULAR CHECKS, CLEANING/MAINTENANCE, TROUBLE SHOOTING & REPAIRS

19 REGULAR CHECKS

21 CLEANING/MAINTENANCE

22 TROUBLE SHOOTING

23 RECIPE IDEAS

23 3 MINUTE STIR FRY

24 LETTUCE CUPS

25 MARION'S KITCHEN SWEET CHILLI COCONUT CURRY

26 CHOW MEIN

27 UNCLE ROGER'S EGG FRIED RICE

CONTENTS CONT.

THANK YOU FOR YOUR SUPPORT

Thank you for purchasing a Wok 'n' Roll Equipment Inferno20 Wok Burner.

This Wok Burner will allow you to cook the most amazing Fried rice, stir fries, curries, and many more beautiful meals.

Wok 'n' Roll Equipment also provides a range of compatible accessories to enhance your wok cooking experience.

CONTACT INFORMATION

- Email: woknrollequipment@gmail.com
- Phone: 0435 857 399
- Website: woknrollequipment.com.au

PACKAGE CONTENTS

This package contains:

- These Instructions
- 1 x Inferno20 High Pressure Wok Burner with the factory fitted High Pressure Hose and Regulator
- 1 x Control knob (to be fitted in place)
- 1 x Warranty information slip

BEFORE USE

- Carefully read this instruction manual.
- Carefully inspect the appliance to ensure there is no damage. If there is any damage, do not use the appliance and contact Wok 'n' Roll Equipment PTY LTD.
- Ensure all packaging has been removed.
- Familiarise yourself with the appliance before connecting it to its gas supply.
- Ensure that the hose is not kinked or in contact with any part of the stove other than at its connection.
- Leak test all connections (as explained in "Regular Checks, Cleaning, Maintenance, Trouble Shooting and Repairs"). Repeat this each time you refill or swap your gas bottle.
- Ensure all cookware (woks, pots and pans) are stable on the wok burner. Cookware that is unstable should not be used.
- Recommended wok size: 350mm - 500mm.

IMPORTANT SAFETY INFORMATION

Model: Wok 'n' Roll – Inferno20 High Pressure Wok Burner

Important:

- Read these instructions for use carefully!
- Familiarise yourself with the appliance before connecting it to its gas container.
- Keep these instructions for future reference.

This appliance shall only be used with LPG from a refillable cylinder (gas bottle) that is certified to Australian Standard AS2030.1.

Heat Capacity: 20kWh or 72Mj

Nominal Gas Consumption: 1.5kg/h

Injector Size: 0.91mm

WARNING

IT MAY BE HAZARDOUS TO ATTEMPT TO FIT OTHER TYPES OF GAS CONTAINERS.

ONLY USE IN WELL-VENTILATED AREAS.

CARBON MONOXIDE HAZARD – USING THIS APPLIANCE IN AN ENCLOSED SPACE MAY CAUSE DEATH. DO NOT USE IN CARAVANS, TENTS, MARINE CRAFT, CARS, MOBILE HOMES OR SIMILAR LOCATIONS.

CAUTION

ACCESSIBLE PARTS MAY BE VERY HOT. KEEP YOUNG CHILDREN AWAY.

USE OUTDOORS ONLY.

WOK 'N' ROLL

POSITIONING OF APPLIANCE

Any enclosure in which the appliance is used shall comply with one of the following:

(A) An enclosure with walls on all sides, but with no overhead cover (example 1).

(B) Within a partial enclosure that includes an overhead cover and no more than two walls (example 2 & 3).

(C) Within a partial enclosure that includes an overhead cover and more than two walls, the following shall apply:

- (1) At least 25% of the total wall area is completely open (examples 4 & 5).
- (2) 30% or more in total of the remaining wall side, back and front wall areas is open and unrestricted (examples 4 & 5).
- (3) In the case of balconies, 20% or more of the total wall area shall remain open and unrestricted.

EXAMPLE ONE

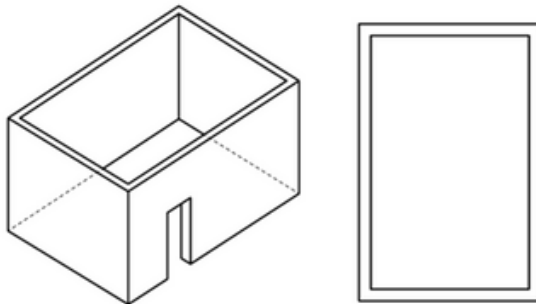

WOK 'N' ROLL

EXAMPLE TWO

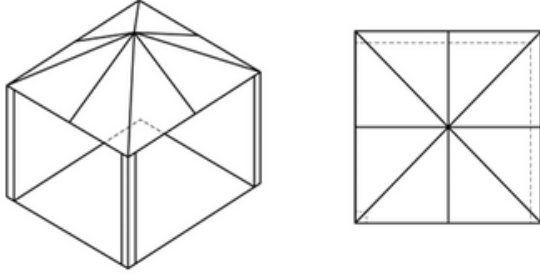

EXAMPLE THREE

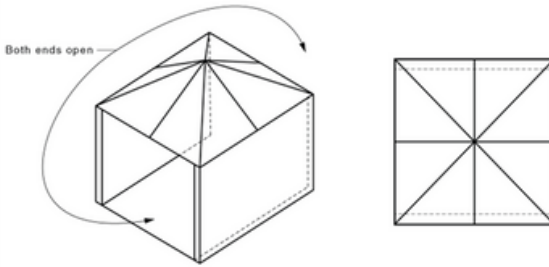

EXAMPLE FOUR

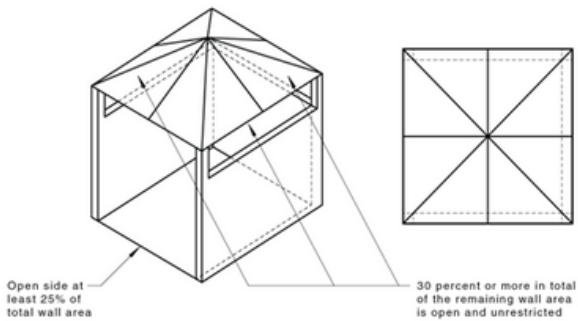

WOK 'N' ROLL

EXAMPLE FIVE

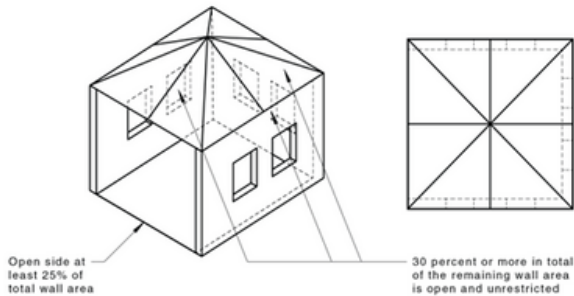

The appliance must be sited with at least a **600mm** gap between the; front, back and sides of the appliance and any combustible material.

The appliance must have a clearance of **1500mm** from the trivet of the appliance and any combustible or non-combustible materials above the trivet of the appliance.

Ensure that the surface the burner is used on is level and stable.

The wok burner may be sitting on a surface on its feet, or suspended by its upper rim inside a hole in the surface.

The wok burner must be used on a non-combustible surface.

The appliance should be protected from drafts and rain as they could affect the flame.

Do not move the appliance or attempt any maintenance during use or within 30 minutes of the wok burner being used.

WOK 'N' ROLL

GAS CONNECTION

The Wok 'n' Roll – Inferno20 High Pressure Wok Burner comes as standard with a 1200mm Stainless Steel Braided hose and 150kpa High Pressure Regulator.

This connects the Wok Burner to a gas bottle using a Type 27 fitting also known as the Leisure Cylinder Connection (LCC27).

This Type 27 (LCC27) fitting is the new standard fitting across all small portable LPG cylinders and appliances that run off these small portable LPG cylinders.

Only use the hose assembly as supplied with this appliance for connection to the cylinder - DO NOT USE ADAPTORS.

This appliance must only be serviced by an authorized person.

GAS CYLINDER

Only cylinders which comply with AS2030.1 should be used. The appliance is suitable for use with gas cylinders of 3.9 kg to 15 kg gas capacity.

The gas cylinder should be stored / used in the upright position.

The appliance is not suitable for installation or connection to a reticulated gas supply.

Gas containers shall be changed in a well-ventilated location, preferably outside away from people and any sources of ignition, such as naked flames, pilot flames, electric heaters/equipment.

WOK 'N' ROLL

OPERATION

Once the wok burner has been positioned on a non-combustible surface and is connected to a gas bottle the wok burner is ready to be used.

1. Turn the gas bottle on.
2. Push in and twist (anti-clockwise) the control knob to ignite the burner.
3. Adjust the heat output by turning the control knob.
(Once ignited the burner will produce more heat the further anti-clockwise you turn the control knob).
4. Place your wok on the wok burner and commence cooking.
5. Once the cooking is complete, turn off the gas bottle allowing the gas in the line to be used up, causing the flame to go out, then turn the control knob to the off position.
6. When not in use, disconnect the wok burner from the gas bottle and store in a dry location
7. Gas Cylinders shall be stored outdoors in a well-ventilated area out of the reach of children. Any indoor storage information shall be consistent with AS/NZS 1596.

5 THINGS YOU NEED TO KNOW BEFORE YOU START WOK COOKING:

1. Cooking Setup: Trolley/table, wok and wok tools.
2. Wok Seasoning: For a non-stick and rust resistant wok.
3. Wok Cleaning and Care: For a wok that lasts a lifetime.
4. Pantry Must Haves: Ingredients to level up your wok game.
5. Food Prep: With such high heat, there is no time to waste chopping ingredients.

WOK 'N' ROLL

COOKING SETUP

Congratulations on your Wok Burner purchase!

This wok burner is a serious bit of gear which will allow you to take your home cooking to the next level.

Here are a few recommendations for when you are setting yourself up, to allow you to get the most out of your wok burner.

Trolley/table:

The trolley/ table you use should be sturdy and even ideally hold your wok burner in place as this will allow you to toss and turn the contents of your wok as vigorously as you like.

This is important as, when cooking over such high heat, keeping the ingredients moving will allow them to cook evenly and prevent them from burning and sticking to the bottom of your wok.

WOK 'N' ROLL

COOKING SETUP

Wok:

Selecting the right wok is important when beginning your wok cooking journey and there are plenty of options including; cast iron, non-stick coated, stainless steel, and carbon steel.

Our recommendation is a carbon steel wok with a handle that doesn't get hot. This is what you will typically find wok chefs using in restaurant kitchens.

These type of woks are light weight, making them easy to toss and, once seasoned, they provide a durable and non-stick cooking surface.

Your wok will ideally have a handle that does not get hot (such as timber) to allow you to easily manipulate the wok while it is hot.

Recommended wok size: 350mm - 500mm.

Wok Tools:

Wok tools such as; wok ladles, wok turners and spiral skimmers will all extend and improve your wok cooking capability.

These tools should have long handles that are resistant to damage from the heat of the wok.

WOK SEASONING

Typically, carbon steel woks will come from the manufacturer as raw carbon steel with an oil coating on them to prevent rust in transit.

These woks must be seasoned in order to make them more non-stick and rust resistant.

There are countless 'how to videos' and 'set by step' instructions on the internet explaining how to season cast iron and carbon steel, all of which follow the same basic process.

Essentially, you should clean your new carbon steel wok and dry thoroughly, then add a very thin layer of an oil with a high smoke point and finally, bake this on to the carbon steel.

Through a process called polymerisation, the liquid oil turns into a hard, smooth surface that is molecularly bonded to the base metal.

This process should be repeated 2 or 3 times to ensure a robust seasoning has been achieved.

When choosing an oil, there are all manner of theories about which oil is the best. However, we always use vegetable oil as it is cheap, readily available and works brilliantly.

WOK CLEANING AND CARE

Like all pot and pans, your Wok will need to be cleaned after use.

Again, there are all manner of theories about 'what to do' and 'what not to do' when it comes to cleaning carbon steel.

What we have found to work the best is giving the wok a good scrub with a stainless steel scourer in warm soapy water, then drying thoroughly.

* A great way to dry the wok is using heat from the wok burner.

Once the wok is dry, wipe it over with a very thin coating of vegetable oil (or similar) to prevent corrosion in between uses.

PANTRY MUST HAVES

One of the biggest improvements you can make to your wok cooking game is to use the best ingredients you can get.

Often this means branching out from your normal grocer and using ingredients you might not be used to.

The biggest learning moment for some people might be, for example, that there is more than one type of soy sauce.

Over the next few pages we have provided a brief summary of what we consider to be 'must haves' for you to get the most from your wok cooking.

PANTRY MUST HAVES

Soy Sauces:

- Normal soy sauce is used to bring salty and umami flavours.
- Dark soy is similar but sweeter and brings a darker colour to the dish.
- Sweet soy or Kecap Manis is a really sweet, thick sauce.

Oyster Sauce and Fish Sauce:

- Oyster sauce is thick, rich and very savoury (umami).
- Fish sauce, typically made from anchovies is salty with flavours of brine and caramel.

Rice Wine and Rice Vinegar:

- Rice wine or Shaoxing wine, like sherry brings a dry complex flavour to dishes such as fried rice.
- Rice vinegar, as the name suggests brings a vinegary flavour that can really enhance things like Chow Mein.

Oils:

- Vegetable oil is cheap and has a neutral flavour so is a good option for wok seasoning and maintenance. It's also great for deep frying and preventing food from sticking without influencing the flavour of the dish.
- Peanut oil brings a light nutty flavour to the dish and has a high smoke point so is good for high heat stirfrys.
- Sesame oil has a very strong earthy and nutty flavour, so should mostly be used as a seasoning as opposed to a cooking oil.

PANTRY MUST HAVES

Aromatics:

- Garlic, although often used in western cooking, is a huge part of wok cooking and the quantities suggested may frighten you at first, but you absolutely must have this available.
- Ginger brings a spicy and zesty flavour to the fore of a dish, without which a lot of dishes are left bland and boring.
- Spring onion whites are great in addition to normal brown onion in a dish. Additionally the green parts are excellent as a garnish in a dish adding bright colour and freshness.

Dry Goods:

- Corn starch or corn flour is used to thicken a sauce, helping it cling to the ingredients in the dish you're cooking, such as noodles.
- White pepper brings a subtle and pleasant heat to a dish that lingers, without burning your mouth the way a chilli might.
- MSG, while it may sound scary (and you can leave it out if you like), brings an incredibly umami flavour to a dish making it irresistibly moreish. There is a reason it is so popular in Asian cooking.

FOOD PREPARATION

When wok cooking, one of the main objectives is to achieve 'Wok Hei'. Literally translated this means 'breath of the wok' and refers to the beautiful smokey flavour achieved by cooking using extreme heat.

Scientifically this is known as the Maillard reaction, where sugars and proteins, brown and caramelize due to high heat creating a distinct flavour.

However, if you're not careful and the Maillard reaction goes too far, you can burn your food.

To prevent your food from burning, but still achieve a good Maillard reaction, you must keep your food moving, by tossing and turning it.

This means that once you start cooking, you will not have time to chop up any ingredients or fetch them from a distance.

Therefore, it is absolutely imperative that you have all of your ingredients prepared and portioned into their own dishes and have them within arm's reach once the wok burner is turned on.

In French this preparation of ingredients is known as *Mise en Place* and is now common practice in restaurants across the world.

WOK 'N' ROLL

REGULAR CHECKS, CLEANING/MAINTENANCE, TROUBLE SHOOTING AND REPAIRS

DO NOT MODIFY THIS APPLIANCE.

FOR ALL CLEANING AND MAINTENANCE (WHERE APPLICABLE), ENSURE THE GAS BOTTLE IS TURNED OFF AND DISCONNECTED FROM THE APPLIANCE.

REGULAR CHECKS

Visual check of air flow venturi entry and pilot burner

1. If blocked, remove blockage using a toothpick or similar.

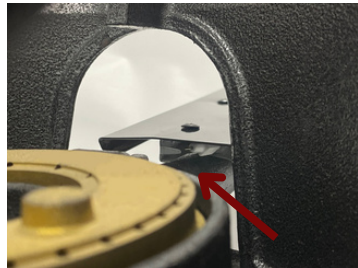
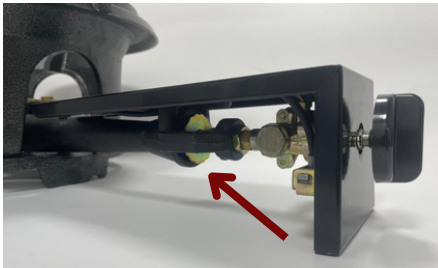

Gas leak test

1. Mix one teaspoon of dish washing liquid with half a cup of water.
2. Turn gas bottle on to pressurise the gas line.
3. Using a paint brush apply the mixture to all gas connections.
4. If you notice any bubbling or spitting of the mixture, there is a leak, and the leaking component must be replaced.

Visual Check of condition of hose and regulator

1. If the hose or regulator is worn or damaged, replace immediately

WOK 'N' ROLL

Visual check for orange flame

If the flame is orange, adjust the air inlet as follows:

1. Loosen the Locking Nut next to the Airflow Adjustment Wheel (indicated in the diagram below).
2. Now the Airflow Adjustment Wheel is free to move, place the wok burner on its feet on a level, non-combustible surface and ensure it is stable.
3. Turn the burner on to high.
4. Rotate the Airflow Adjustment Wheel to allow more air to mix with the gas until a nice blue flame is achieved.
5. Turn the burner off.
6. Tighten the Locking Nut to secure the Airflow Adjustment Wheel in place.
7. If this does not work, the hose and regulator should be replaced.

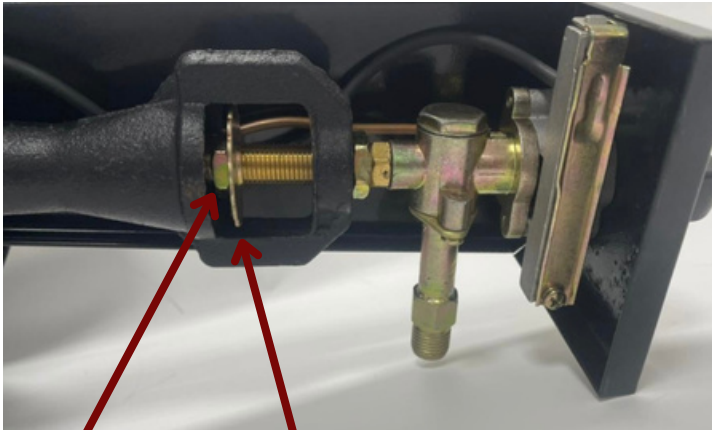

Locking Nut

Airflow Adjustment Wheel

WOK 'N' ROLL

CLEANING/MAINTENANCE

Keep the wok burner clean by wiping with a damp cloth after each use.

For a deep clean (recommended once per year) to remove any rust or food remnants, the burner can be disassembled into the parts seen below and scrubbed with steel wool in warm soapy water.

* The valve, jets, ignition and regulator should never be disassembled.

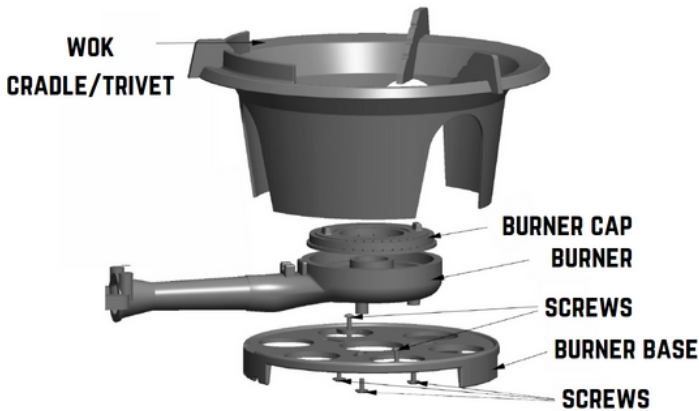

It is recommended that the hose and regulator assembly should be replaced every 5 years. The use of any equivalent hose (max 1.2 metres) and regulator assembly that is certified compliant with the Australian Standards by the Australian Gas Association is acceptable.

You can buy replacement parts from Wok 'n' Roll Equipment PTY LTD or your local Wok 'n' Roll Equipment PTY LTD Stockist.

WOK 'N' ROLL

TROUBLE SHOOTING

If you notice any abnormal operation, stop use, turn off gas and allow to cool before carrying out any checks.

Won't ignite:

1. Ensure there is gas in the gas bottle and the connections are secure.
2. Clean the pilot ignition burner outlet with a toothpick.
3. Try different timing (between 0 and 3 seconds) between pushing the control knob in and twisting the control knob creating the spark.
4. If none of this works, the ignition/ valve needs to be replaced.

Not getting hot:

1. Ensure there is gas in the gas bottle and the connections are secure.
2. Check airflow venturi entry for blockages. If blocked, remove blockage.
3. Check burner holes for blockages. If blocked, remove blockage and clean.
4. If none of this works, the hose and regulator need to be replaced.

Leak/ smell of gas:

1. Immediately attempt to turn off the cylinder valve.
2. Remove the appliance to a well-ventilated location away from any ignition source.
3. Do the soapy water gas leak test to find the gas leak and replace that component.
4. Do not try to detect leaks using a flame.

RECIPE IDEAS

3 MINUTE STIR FRY

Ingredients

- Peanut oil
- Meat of choice, sliced
- 3 Tbsp sesame oil
- 1 red onion, roughly chopped strips
- 1 bunch of broccolini, quartered
- 1 bunch of asparagus, quartered
- 1 carrot, roughly chopped strips
- 2 Tsp garlic, minced
- 1 Tsp ginger, minced
- 1/4 cup soy sauce
- 1 handful sugar snap peas, topped (stems removed)
- Steamed rice, to serve

Method

1. Cook meat with peanut oil in wok on high heat until cooked and then remove.
2. Add red onion and stir fry for **1 minute**.
3. Add broccolini, asparagus and carrot. Stir fry for **1 minute**.
4. Add garlic, ginger, soy sauce and sugar snap peas. Stir fry for **1 minute**.
5. Add pre-cooked meat back in for a final toss.
6. Serve with rice.

WOK 'N' ROLL

LETTUCE CUPS

Ingredients

- Lettuce, picked off into cups
- Peanut Oil
- 500 grams pork mince
- 1 small onion, finely diced
- 3 garlic cloves, minced
- 2 Tbsp ginger, minced
- Salt and pepper to taste
- 1 small carrot, finely diced
- 1 green onion, finely diced (separate green & white sections)
- 1 Tbsp Corn flour mixed with water
- Sesame seeds for garnish
- Sauce, premade
 - 1 Tbsp oyster sauce
 - 1 Tbsp sesame oil
 - 1 Tbsp soy sauce
 - 1 Tbsp sugar
 - Chilli flakes (optional)

Method

1. Heat oil in a wok. Sauté onion, white green onion, ginger and garlic for 30 seconds.
2. Add the mince and stir fry until cooked.
3. Add the carrot. Stir fry till cooked.
4. Add the sauce and toss through.
5. Add the corn starch and water mixture and allow to thicken.
6. Garnish with sesame seeds and remaining green onions.
7. Serve in lettuce cups.

MARION'S KITCHEN SWEET CHILLI COCONUT CURRY

Ingredients

- 600g (1.3lb) chicken thigh fillets, cubed
- 1 bottle Marion's Sticky Chilli Marinade
- 2 Tbsp vegetable oil
- 400ml (14 oz) can coconut milk
- 1 Tbsp fish sauce
- 10 fresh Thai basil leaves
- 2 long red chillies, finely sliced
- Optional: Greens of choice (beans, etc)
- Steamed rice, to serve

Method

1. Mix the chicken in a bowl with 2 tablespoons of the marinade.
2. Cook chicken with oil in wok on high heat until golden.
3. Now add the coconut milk, remaining marinade and fish sauce to the wok.
4. Reduce to a simmer for 10 minutes.
5. Add greens for an additional 2 minutes or until cooked.
6. Stir through the basil and red chillies and serve with steamed rice.

I strongly recommend you check this recipe out at:

<https://www.marionskitchen.com/coconut-sweet-chilli-chicken/>

WOK 'N' ROLL

CHOW MEIN

Ingredients

- Peanut oil for frying
- 4 chicken thighs, sliced
- 2 green onions, rough chop
- 1 carrot, julienne
- 2 ribs celery, diced
- 1/2 napa cabbage, thinly sliced
- 7 cloves garlic, finely chopped
- 1 cup bean sprouts
- 400g Chow Mein/stir fry noodles, cooked for 10 seconds, and rinsed with cold water to stop the cooking
- Sauce
 - 1.5 Tbsp rice vinegar
 - 2.5 Tbsp soy sauce
 - 2 Tbsp hoisin sauce
 - 0.5 Tbsp toasted sesame oil
 - 1 Tbsp corn starch

Method

1. Cook chicken with oil in wok on high heat until golden, then remove.
2. Add green onions, stir fry until wilting.
3. Add 3/4 of your garlic, stir fry until golden brown.
4. Add celery, carrots and cabbage and stir fry until wilting.
5. Add chicken back in and noodles, then toss and reduce heat.
6. Add Chow Mein sauce and water then toss.
7. Cut the heat and add the rest of the garlic and toss.
8. Add soy sauce to taste and toss.
9. Garnish with green onion and chilli oil.

WOK 'N' ROLL

UNCLE ROGER EGG FRIED RICE

Ingredients

- Peanut oil
- 5 cloves of garlic, minced
- 2 shallots, diced
- 3 eggs
- 3 cups of leftover rice
- 1 Tbsp white pepper
- 1 Tbsp MSG
- 3 sticks spring onion, diced
- Sauce
 - 3 cloves garlic, minced
 - 3 cloves worth of ginger, minced
 - 1 Tbsp sweet soy sauce
 - 1 Tbsp dark soy sauce
 - 1 Tbsp sesame oil

Method

1. Heat up peanut oil.
2. Add garlic and shallots. Stir fry until they have some colour.
3. Add eggs, and stir fry until cooked.
4. Add rice and mix.
5. Add white pepper and MSG.
6. Add sauce mixture.
7. Add spring onion for the last few seconds of cooking as a garnish.

I strongly recommend you check this recipe out at:

<https://www.youtube.com/watch?v=SGBP3sG3a9Y>