



WARNING

PLEASE READ THE ENTIRE CONTENTS OF THIS MANUAL PRIOR TO INSTALLATION AND OPERATION. BY PROCEEDING YOU AGREE THAT YOU FULLY UNDERSTAND AND COMPREHEND THE FULL CONTENTS OF THIS MANUAL. FORWARD THIS MANUAL TO ALL OPERATORS. FAILURE TO OPERATE THIS EQUIPMENT AS DIRECTED MAY CAUSE INJURY OR DEATH.

Manual Rev. B - Sept. 2020

Manual P/N 590005

INSTALLATION AND OPERATION MANUAL

PARKING LIFT / 7,000 POUND CAPACITY

Models:

- PL-7000DLX
- PL-7000DLX-G



READ FIRST



Do not operate this machine until you read and understand all the dangers, warnings and cautions in this manual.



Keep this operation manual near the machine at all times. Make sure that ALL USERS read this manual.

SHIPPING DAMAGE CLAIMS

When this equipment is shipped, title passes to the purchaser upon receipt from the carrier. Consequently, claims for the material damaged in shipment must be made by the purchaser against the transportation company at the time shipment is received.

BE SAFE

Your new lift was designed and built with safety in mind. However, your overall safety can be increased by proper training and thoughtful operation on the part of the operator. DO NOT operate or repair this equipment without reading this manual and the important safety instructions shown inside.



1645 Lemonwood Dr.
Santa Paula, CA. 93060, USA
Toll Free 1-800-253-2363
Tel: 1-805-933-9970
Fax: 1-805-933-9160
www.bendpak.com

PARKING LIFT

This instruction manual has been prepared especially for you.
Your new lift is the product of over 50 years of continuous research, testing and development

READ THIS ENTIRE MANUAL BEFORE INSTALLATION & OPERATION BEGINS

RECORD HERE THE LIFT AND
POWER UNIT INFORMATION WHICH IS
LOCATED ON THE SERIAL NUMBER
DATA PLATES ON THE LIFT AND
ON THE POWER UNIT

Power Unit Model # _____
Power Unit Date Of Mfg. _____
Power Unit Serial # _____

This information is required when
calling for parts or warranty issues.

BP BendPak Santa Paula, CA USA www.bendpak.com	
MODEL NUMBER	
SERIAL NUMBER	
LIFT CAPACITY	DESCRIPTION
VOLTAGE / AMPERAGE	
<input type="checkbox"/> 1 Phase, 208-230/220VAC, 2 Hp, 10.5-11.6/21.0 A, 60/50 Hz	
<input type="checkbox"/> 3 Phase, 208-230/190VAC, 2 Hp, 6.1-6.5/7.0 A, 60/50 Hz	
<input type="checkbox"/> 3 Phase, 460/380VAC, 2Hp, 3.3/3.5 A, 60/50 Hz	
DATE OF MFG.	
DANGER! Disconnect Power Before Servicing	
PN 590000	
WARRANTY VOID IF DATA PLATE IS REMOVED	

PRODUCT WARRANTY

BendPak Parking Lifts Lifts are covered under warranty for one year on equipment structure, to be free of defects in material and workmanship. Power units, hydraulic cylinders, and all other assembly components such as turnplates, slip plates, cables, chains, valves, switches etc. are covered under warranty for one year against defects in material or workmanship under normal use. BendPak Inc. shall repair or replace at their option for the warranty period those parts returned to the factory freight prepaid which prove upon inspection to be defective. BendPak Inc. will pay labor costs for the first 12 months only on parts returned as previously described.

The warranty does not extend to:

- ◆ defects caused by ordinary wear, abuse, misuse, shipping damage, improper installation, voltage or lack of required maintenance;
- ◆ damages resulting from purchaser's neglect or failure to operate products in accordance with instructions provided in the owner's manual(s) and/or other accompanying instructions supplied;
- ◆ normal wear items or service normally required to maintain the product in a safe operating condition;
- ◆ any component damaged in shipment;
- ◆ other items not listed but may be considered general wear parts;
- ◆ damage caused by rain, excessive humidity, corrosive environments or other contaminants.

THESE WARRANTIES DO NOT EXTEND TO ANY COSMETIC DEFECT NOT INTERFERING WITH EQUIPMENT FUNCTIONALITY OR ANY INCIDENTAL, INDIRECT, OR CONSEQUENTIAL LOSS, DAMAGE, OR EXPENSE THAT MAY RESULT FROM ANY DEFECT, FAILURE, OR MALFUNCTION OF A BENDPAK INC. PRODUCT OR THE BREACH OR DELAY IN PERFORMANCE OF THE WARRANTY.

**WARRANTY IS NOT VALID UNLESS
WARRANTY CARD IS RETURNED.**

IMPORTANT NOTICE

Do not attempt to install this lift if you have never been trained on basic automotive lift installation procedures. Never attempt to lift components without proper lifting tools such as forklift or cranes. Stay clear of any moving parts that can fall and cause injury. These instructions must be followed to insure proper installation and operation of your lift. Failure to comply with these instructions can result in serious bodily harm and void product warranty. Manufacturer will assume no liability for loss or damage of any kind, expressed or implied resulting from improper installation or use of this product.



**PLEASE READ ENTIRE MANUAL
PRIOR TO INSTALLATION.**

DEFINITIONS OF HAZARD LEVELS

Identify the hazard levels used in this manual with the following definitions and signal words:



Watch for this symbol. It means: Immediate hazards which will result in severe personal injury or death.



Watch for this symbol. It means: Hazards or unsafe practices which could result in severe personal injury or death.



Watch for this symbol. It means: Hazards or unsafe practices which may result in minor personal injury, product or property damage.

OWNER'S RESPONSIBILITY

To maintain the lift and user safety, the responsibility of the owner is to read and follow these instructions:

- ◆ Follow all installation and operation instructions.
- ◆ Make sure installation conforms to all applicable Local, State, and Federal Codes, Rules, and Regulations; such as State and Federal OSHA Regulations and Electrical Codes.
- ◆ Carefully check the lift for correct initial function.
- ◆ Read and follow the safety instructions. Keep them readily available for machine operators.
- ◆ Make certain all operators are properly trained, know how to safely and correctly operate the unit, and are properly supervised.
- ◆ Allow unit operation only with all parts in place and operating safely.
- ◆ Carefully inspect the unit on a regular basis and perform all maintenance as required.
- ◆ Service and maintain the unit only with authorized or approved replacement parts.
- ◆ Keep all instructions permanently with the unit and all decals on the unit clean and visible.

BEFORE YOU BEGIN

Receiving:

The shipment should be thoroughly inspected as soon as it is received. The signed bill of lading is acknowledgment by the carrier of receipt in good condition of shipment covered by your invoice. If any of the goods called for on this bill of lading are shorted or damaged, do not accept them until the carrier makes a notation on the freight bill of the shorted or damaged goods. Do this for your own protection.

NOTIFY THE CARRIER AT ONCE if any hidden loss or damage is discovered after receipt and request the carrier to make an inspection. If the carrier will not do so, prepare a signed statement to the effect that you have notified the carrier (on a specific date) and that the carrier has failed to comply with your request.

IT IS DIFFICULT TO COLLECT FOR LOSS OR DAMAGE AFTER YOU HAVE GIVEN THE CARRIER A CLEAR RECEIPT.

File your claim with the carrier promptly. Support your claim with copies of the bill of lading, freight bill, invoice, and photographs, if available. Our willingness to assist in helping you process your claim does not make BendPak responsible for the collection of claims or replacement of lost or damaged materials.

TABLE OF CONTENTS

<u>Contents</u>	<u>Page No.</u>
Warranty / Serial Number Information	2
Definitions of Hazard Levels / Owner's Responsibility	3
Before You Begin	3
Customer Agreement / Protective Equipment	5
Introduction / Safety / Warning Instructions	6
Tools Required	7
Step 1 / Selecting Site	7
Step 2 / Floor Requirements / Concrete Specifications	7
Floor Plan / Specifications	8
Step 3 / Installing Safety Stop Blocks	9
Step 4 / Assembling The Runway Frame	10
Step 5 / Routing The Equalizer Chains	11
Step 6 / Raising The Columns	12
Step 7 / Installing The Hydraulic Cylinders	13
Step 8 / Installing The Lifting Chain	14
Step 9 / Installing The Cylinder Fittings	14
Step 10 / Positioning The Front Support leg Tubes and Front Crossbar	14
Step 11 / Rear Support Tube Installation	14
Step 12 / Routing The Hydraulic Lines	15-16
Step 13 / Installing The Control Bar	17
Step 14 / Installing The Safety Lock Assemblies	17
Step 15 / Installing The Key Switch and Power Cable	18
Step 16 / Mounting the Hydraulic Power Unit	19-20
Step 17 / Wiring the Power Unit	20-24
Step 18 / Power Unit Hook Up.	25
Step 19 / Final Adjustments	25
Step 20 / Lift Start Up	25
Step 21 / Attaching the Front and Rear Crossbars.	26
Step 22 / Final Assembly	26-27
Step 23 / Operation	28-36
Troubleshooting Guide	37-40
Parts Breakdown	42-46
Maintenance Records	47

**INSTALLER / OPERATOR
PLEASE READ AND
FULLY UNDERSTAND.
BY PROCEEDING YOU AGREE
TO THE FOLLOWING:**

- ◆ I have visually inspected the site where the lift is to be installed and verified the concrete to be in good condition and free of cracks or other defects. I understand that installing a lift on cracked or defective concrete could cause lift failure resulting in personal injury or death.
- ◆ I understand that a level floor is required for proper installation and level lifting.
- ◆ I understand that I am responsible if my floor is of questionable slope and that I will be responsible for all charges related to pouring a new level concrete slab if required and any charges.
- ◆ I understand that the lifts are supplied with concrete fasteners meeting the criteria of the American National Standard "Automotive Lifts - Safety Requirements for Construction, Testing, and Validation" ANSI/ALI ALCTV-1998, and that I will be responsible for all charges related to any special regional structural and/or seismic anchoring requirements specified by any other agencies and/or codes such as the Uniform Building Code (UBC) and/or International Building Code (IBC).
- ◆ I will assume full responsibility for the concrete floor and condition thereof, now or later, where the above equipment model(s) are to be installed. Failure to follow danger, warning, and caution instructions may lead to serious personal injury or death to operator or bystander or damage to property.
- ◆ I understand that BendPak lifts are designed to be installed in indoor locations only. Failure to follow installation instructions may lead to serious personal injury or death to operator or bystander or damage to property or lift.

Notes:

- All exposed metal parts of the enclosure shall be bonded to ground.
- An Electrical Permit and Building Permit shall be obtained prior to each installation.



Failure to follow danger, warning, and caution instructions may lead to serious personal injury or death to operator or bystander or damage to property.



Please read entire manual prior to installation. Do not operate this machine until you read and understand all the dangers, warnings, and cautions in this manual.

For additional copies or further information, contact:

BendPak Inc. / Ranger Products

1645 Lemonwood Dr.

Santa Paula, CA. 93060

1-805-933-9970

www.bendpak.com

En Español: www.bendpak.com.mx

**INSTALLER / OPERATOR
PROTECTIVE EQUIPMENT**

Personal protective equipment helps makes installation and operation safer, however, it does not take the place of safe operating practices. Always wear durable work clothing during any installation and/or service activity. Shop aprons or shop coats may also be worn, however, loose fitting clothing should be avoided. Tight-fitting leather gloves are recommended to protect technician hands when handling parts. Sturdy leather work shoes with steel toes and oil resistant soles should be used by all service personnel to help prevent injury during typical installation and operation activities.

Eye protection is essential during installation and operation activities. Safety glasses with side shields, goggles, or face shields are acceptable. Back belts provide support during lifting activities and are also helpful in providing worker protection. Consideration should also be given to the use of hearing protection if service activity is performed in an enclosed area, or if noise levels are high.



THIS SYMBOL POINTS OUT IMPORTANT SAFETY INSTRUCTIONS WHICH IF NOT FOLLOWED COULD ENDANGER THE PERSONAL SAFETY AND/OR PROPERTY OR YOURSELF AND OTHERS AND CAN CAUSE PERSONAL INJURY OR DEATH. READ AND FOLLOW ALL INSTRUCTIONS IN THIS MANUAL BEFORE ATTEMPTING TO OPERATE THIS MACHINE.

INTRODUCTION

1. Carefully remove the crating and packing materials.

CAUTION! Be careful when cutting steel banding material as items may become loose and fall causing personal harm or injury.

2. Check the voltage, phase and proper amperage requirements for the motor shown on the motor plate. Wiring should be performed by a certified electrician only.

IMPORTANT SAFETY INSTRUCTIONS

Read these safety instructions entirely

IMPORTANT NOTICE

Do not attempt to install this lift if you have never been trained on basic automotive lift installation procedures.

Never attempt to lift components without proper lifting tools such as forklift or cranes.

Stay clear of any moving parts that can fall and cause injury.

1. **READ AND UNDERSTAND** all safety warning procedures before operating lift.



2. **KEEP HANDS AND FEET CLEAR.** Remove hands and feet from any moving parts. Keep feet clear of lift when lowering. Avoid pinch points.

3. **KEEP WORK AREA CLEAN.** Cluttered work areas invite injuries.

4. Consider work area environment. Do not expose equipment to rain. **DO NOT** use in damp or wet locations. Keep area well lighted.

5. **ONLY TRAINED OPERATORS** should operate this lift. All non-trained personnel should be kept away from work area. Never let non-trained personnel come in contact with, or operate lift.



6. **USE LIFT CORRECTLY.** Use lift in the proper manner. Never use lifting adapters other than what is approved by the manufacturer.

7. **DO NOT** override self-closing lift controls.

8. **REMAIN CLEAR** of lift when raising or lowering vehicle.

9. **CLEAR AREA** if vehicle is in danger of falling.

10. **ALWAYS ENSURE** that the safeties are engaged before any attempt is made to work on or near vehicle.

11. **DRESS PROPERLY.** Non-skid steel-toe footwear is recommended when operating lift.



12. **GUARD AGAINST ELECTRIC SHOCK.** This lift must be grounded while in use to protect the operator from electric shock. Never connect the green power cord wire to a live terminal. This is for ground only.



13. **DANGER!** The power unit used on this lift contains high voltage. Disconnect power at the receptacle before performing any electrical repairs. Secure plug so that it cannot be accidentally plugged in during service.



14. **WARNING! RISK OF EXPLOSION.** This equipment has internal arcing or sparking parts which should not be exposed to flammable vapors. This machine should not be located in a recessed area or below floor level.



15. **MAINTAIN WITH CARE.** Keep lift clean for better and safer performance. Follow manual for proper lubrication and maintenance instructions. Keep control handles and/o buttons dry, clean and free from grease and oil.



16. **STAY ALERT.** Watch what you are doing. Use common sense. Be aware.

17. **CHECK FOR DAMAGED PARTS.** Check for alignment of moving parts, breakage of parts or any condition that may affect its operation. Do not use the lift if any component is broken or damaged.

18. **NEVER** remove safety-related components from the lift. Do not use lift if safety-related components are damaged or missing.

TOOLS REQUIRED

- ◆ Rotary Hammer Drill Or Similar (If Anchoring)
- ◆ 3/4" Masonry Bit (If Anchoring)
- ◆ 6" blocks or risers
- ◆ 4 Foot Level
- ◆ Open-End Wrenches Metric / SAE
- ◆ Socket And Ratchet Set: Metric /SAE
- ◆ Hex-Key / Allen Wrench Set
- ◆ Medium Crescent Wrench
- ◆ Medium Pipe Wrench
- ◆ Hammer, Crow Bar For Shim Installation
- ◆ Chalk Line
- ◆ Medium Flat Screwdriver
- ◆ Tape Measure: 25 Foot Minimum
- ◆ Needle Nose Pliers
- ◆ Fish Tape, Cable Rope Feed Line
- ◆ Loctite Threadlocker Red or equivalent

IMPORTANT NOTICE

Do not attempt to install this lift if you have never been trained on basic automotive lift installation procedures. Never attempt to lift components without proper lifting tools such as forklift or cranes. Stay clear of any moving parts that can fall and cause injury. These instructions must be followed to insure proper installation and operation of your lift. Failure to comply with these instructions can result in serious bodily harm and void product warranty. Manufacturer will assume no liability for loss or damage of any kind, expressed or implied resulting from improper installation or use of this product.

PLEASE READ ENTIRE MANUAL PRIOR TO INSTALLATION

STEP 1

(Selecting Site)



Before installing your new Parking Lift, check the following.

1. **PARKING LIFT LOCATION:** Always use architects plans when available. Check layout dimension against floor plan requirements making sure that adequate space is available.

2. **OVERHEAD OBSTRUCTIONS:** The area where the parking lift will be located should be free of overhead obstructions such as heaters, building supports, electrical lines etc.

3. **DEFECTIVE FLOOR:** Visually inspect the site where the parking lift is to be installed and check for cracked or defective surfaces.



4. **OPERATING TEMPERATURE.** Operate lift only between temperatures of 41° -104° F.



5. Lift is designed for **INDOOR INSTALLATION ONLY.**

STEP 2

(Floor Requirements)

Specifications of floor must be adhered to. Failure to do so could cause parking lift failure resulting in personal injury or death.

A level floor is required for proper installation. Small differences in floor slopes may be compensated for by proper shimming.

- ◆ DO NOT install this parking lift on any surface other than concrete or asphalt.
- ◆ DO NOT install this parking lift on any surface that slopes more than 1" laterally or 2" longitudinally per unit location. If a floor is of questionable slope, consider a survey of the site and/or the possibility of installing a new level site.
- ◆ DO NOT install this parking lift on expansion seams or on cracked or defective concrete or asphalt.
- ◆ DO NOT install parking lift on a second or elevated floor without first consulting building architect.
- ◆ DO NOT install this lift outdoors.

CONCRETE SPECIFICATIONS	
LIFT MODEL	CONCRETE REQUIREMENTS
7,000 Lb Models	4.25" min. thickness / 3,000 PSI



New concrete must be adequately cured by at least 28 days minimum.

NOTE:

This lift is designed to be installed in groups (bolted together) of three units or more. For installation of single or double units only it is suggested to anchor to the floor using 3/4" concrete anchors.

Consult a Pavement Contractor to determine if your Asphalt Surface meets Recommended Minimum Pavement Thickness and Design to Support Auto Stacker (s).

Specifications

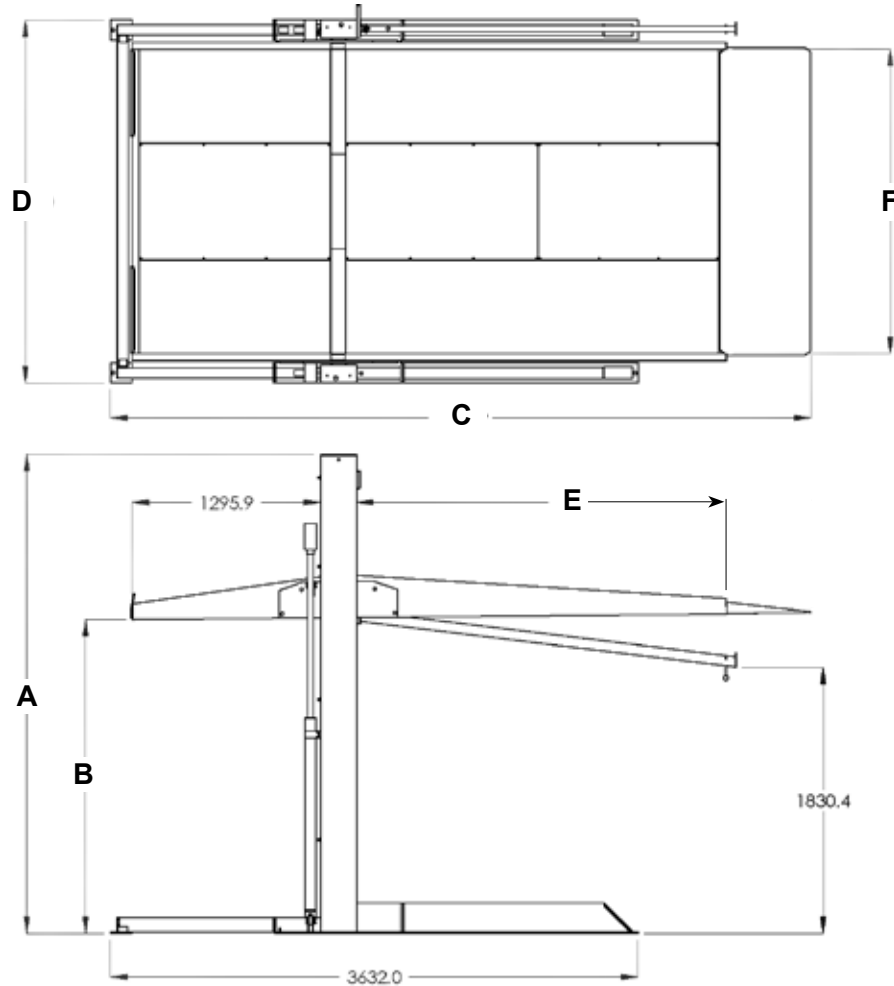

When removing the lift from shipping angles pay close attention as the columns can slide and can cause injury. Prior to removing the bolts make sure the posts are held securely by a fork lift or some other heavy lifting device.

MODEL	PL-7000DLX	PL-7000DLX-G
Lifting Capacity	7,000 Lbs. / 3,175 Kg.	7,000 Lbs. / 3,175 Kg.
A - Height Overall	130" (3,296 mm)	130" (3,296 mm)
B - Rise	85" (2,159 mm)	85" (2,159 mm)
C - Overall Length	190" (4,822 mm)	190" (4,822 mm)
D - Overall Width	98" (2,489 mm)	98" (2,489 mm)
E - Platform Length	157.5" (4,001 mm)	157.5" (4,001 mm)
F - Platform Width	85" (2,165 mm)	85" (2,165 mm)
Lifting Time	30 Seconds	30 Seconds
Motor (*)	220 VAC, 60 Hz., 1Ph	220 VAC, 60 Hz., 1Ph
*Special voltages available on request.		
The design, material, and specifications are subject to change without notice.		

STEP 3

(Installing Safety Stop Blocks)



IMPORTANT NOTE

Prior to assembly of the Lift components, you must determine the Locked Height of the lift, Dimension "B". Use the chart (See Fig 3.2) to determine where to bolt the Safety Stop Block on the Powerside Lift Head.

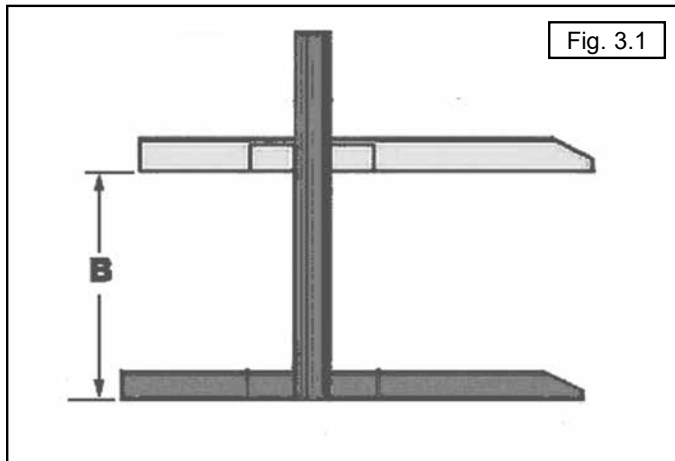

Position	Locked Height "B"
PL-7000DLX	
1	2,156 mm / 84"
2	2,093 mm / 81.5"
3	2,030 mm / 80"
4	1,967 mm / 77"
5	1,904 mm / 74"
6	1,841 mm / 72"
7	1,778 mm / 70"
8	1,715 mm / 67"
9	1,652 mm / 64.5"

Fig. 3.2

1. Lay the Powerside and Offside Columns on the ground with the open end of the column facing up.
2. Remove the Lift Head from the Column by sliding the Lift Heads up out of the top of the Powerside and Offside Columns. (See Fig 3.3)

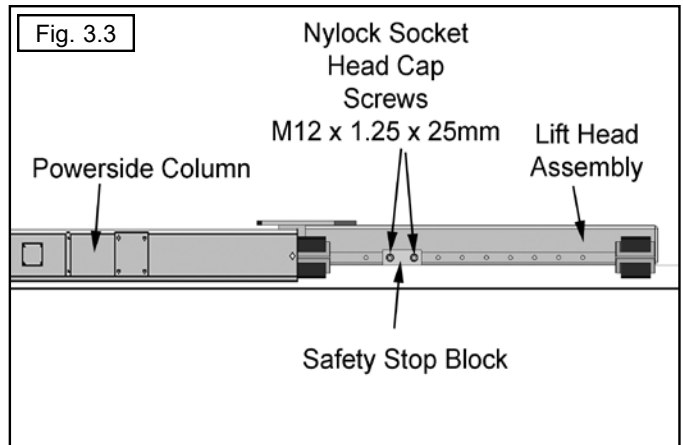

3. Using the chart (Fig. 3.1 and Fig. 3.2), locate the desired position for the Safety Stop Block. (See Fig 3.4)

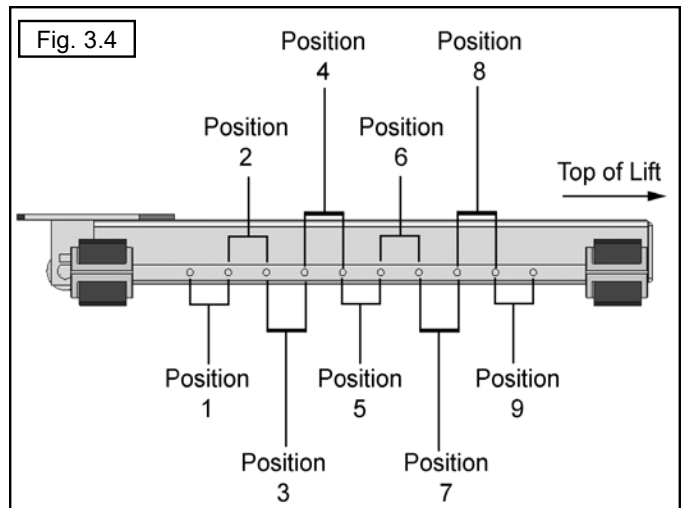

4. Screw the Safety Stop Block in place using the two M12 x 1.25 x 25 mm Socket Head Cap Screws. Torque Socket Head Cap Screws to 50 ft/lbs (68 Nm). (See Fig 3.5)

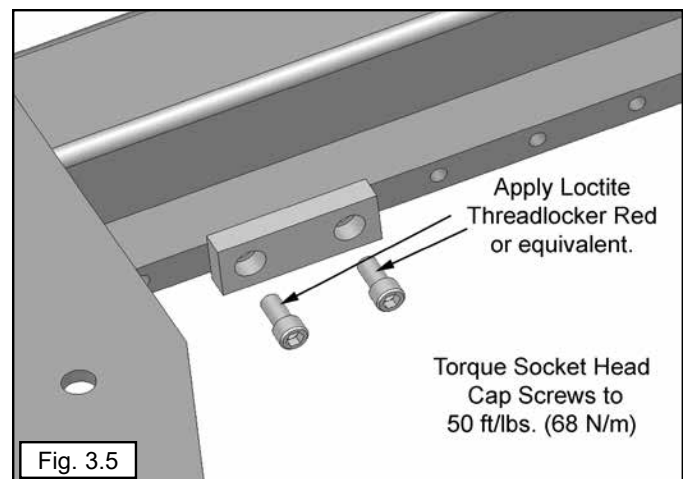

STEP 4

(Assembling the Runway Frame)

IMPORTANT

Laying the runway components on 6" lift blocks or risers will assist in the assembly of the lift components and provide better alignment of the lift heads and runways.

1. In the area of installation, assemble the right side and left side runways together with the center tube as shown below using eight M12 x 1.75 x 40 Hex Head Bolts, M12 x 1.75 Hex Nuts and Spring Lock Washer. (See Fig. 4.1)

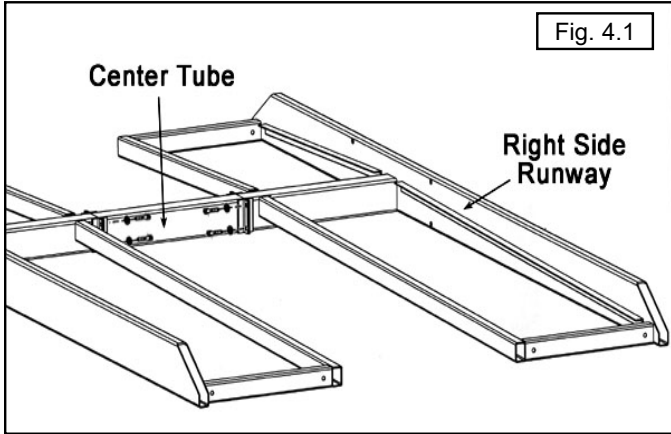

2. Before proceeding, make certain the lift is positioned with clearances around and overhead.

IMPORTANT NOTE

A level floor is suggested for proper installation. If a floor is of questionable slope, (more than 1" side to side or 2" within the full length of the lift) consider pouring a new foundation.

3. Before proceeding, identify the POWER SIDE COLUMN and OFF SIDE COLUMN(S). Note: The Powerside Column has mounting plates for the Control Bar and Power Unit. (See Fig. 4.2)

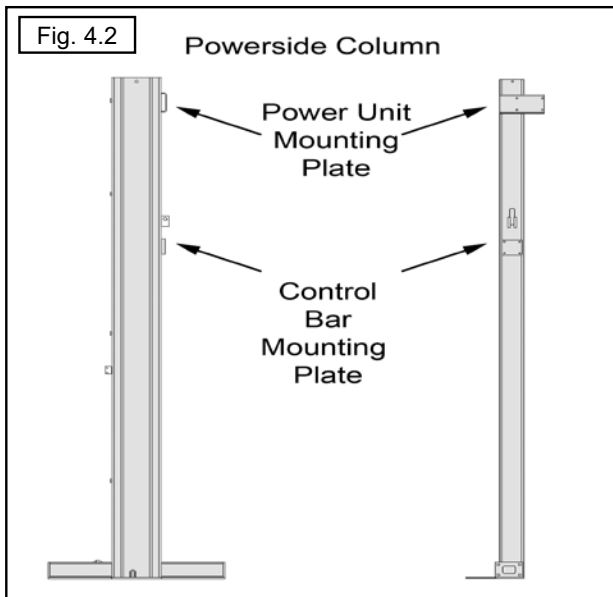

STEP 5

(Routing the Equalizer Chains)

1. In the area of installation, lay the columns down adjacent their respective sides of the runways with the opening of the columns facing up and the base(s) adjacent to the runways. (See Fig. 5.1)

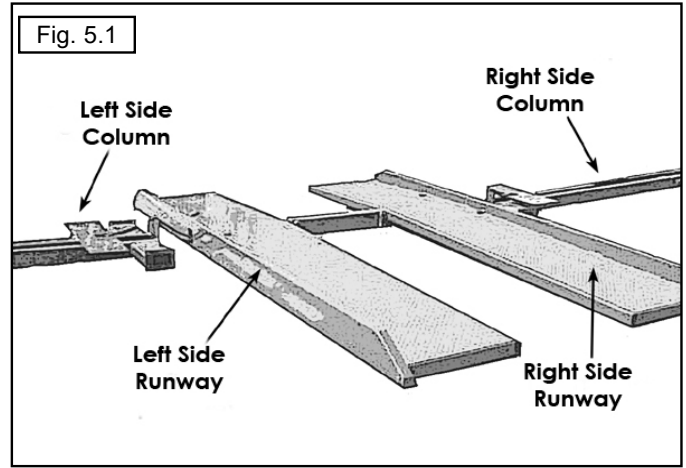

2. With the columns laying flat on the ground slide the lifting Carriage away from the base of the Column to expose the rectangular shaped Chain Connector welded at the base of each Column.
3. Using a fish tape or long wire, route the equalizer Chains through the center tube of the runway assembly making sure they are not twisted and lying adjacent each other flat on the bottom of the Center Tube.
4. Leave the excess Chain in equal amounts on each side of the Runway assembly.
5. Using the diagrams on the following page as a reference, route the Chains **over and under** the roller on the Lift Carriage then connect one side of each chain to the Chain Connector welded at the base of each Column. The Chain routed under the roller will be connected later to the Column Top Plate. When the Columns are lifted to the upright position, the chain routing should resemble the diagram on the following page.

NOTE:

The two Carriage Chain Rollers in each Carriage are mounted side by side so before proceeding identify which side the bottom Chain Connector is welded to so the Chains will be routed properly.

Following the diagrams below to properly route the equalizer chains.

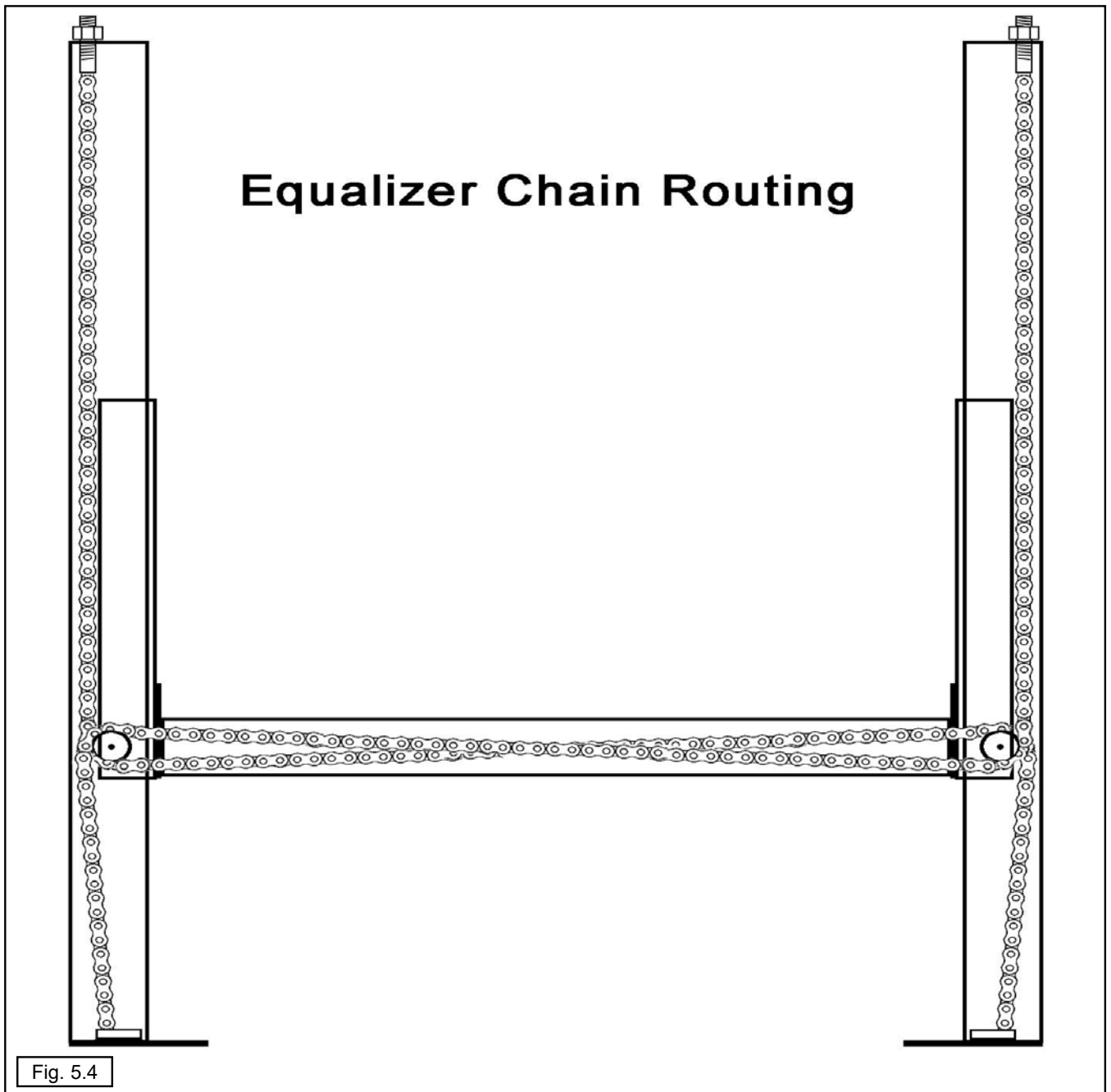
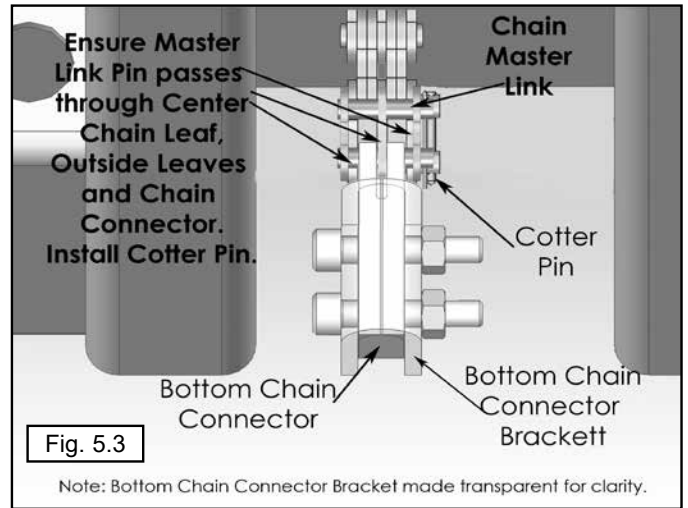
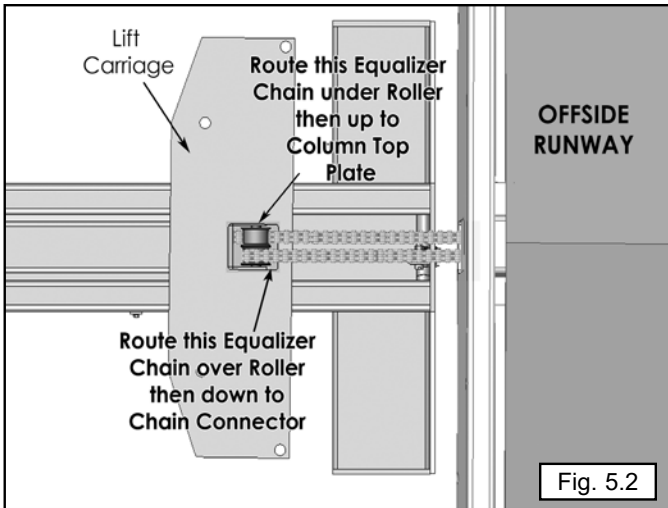

STEP 6

(Raising The Columns)



Do not attempt to proceed unless you have additional trained personnel / manpower to assist, a forklift and cargo straps or chains, and/or a lifting crane.

IMPORTANT NOTE:

Before raising each Column tie-off/tape the unattached end of the Equalizer Chain so that it does not fall inside the Column. Make sure that each lift Carriage is positioned towards the bottom of each Column and that the Equalizer Chains are pulled tight. The Lift Carriage will slide downward rapidly when raising the Column if it is not first positioned towards the bottom of the column. **KEEP HANDS CLEAR.**

1. Using a forklift or crane, raise the Powerside Column upright then slide towards the Runway assembly so that the carriage/runway mounting bolt holes line up. If 6" lifting blocks were not used, it will be necessary to elevate the Runway assembly minimum 1" off the floor in order to slide the Base Plate of each Column underneath the Runway assembly. (See Fig. 6.1 & 6.2)

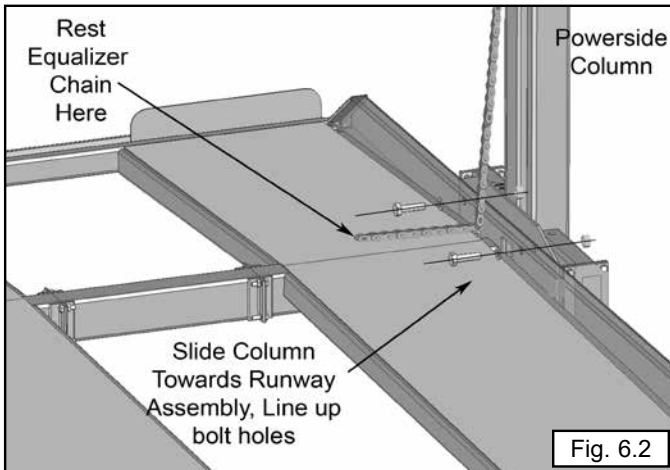
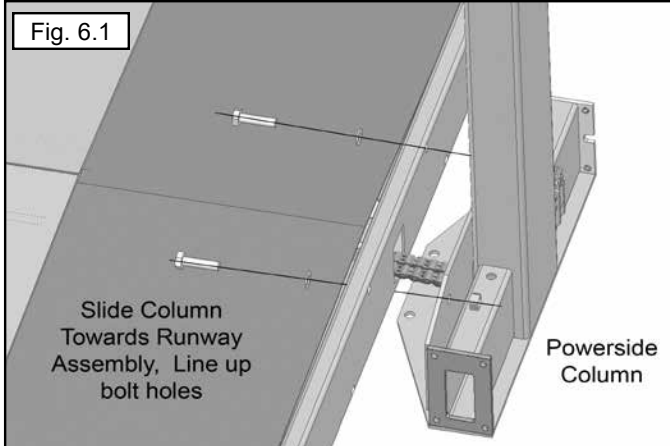

2. Install two M20 x 2.5 x 80 mm Hex Bolts and Nyloc Nuts as shown below. (See Fig. 6.3 & 6.4)

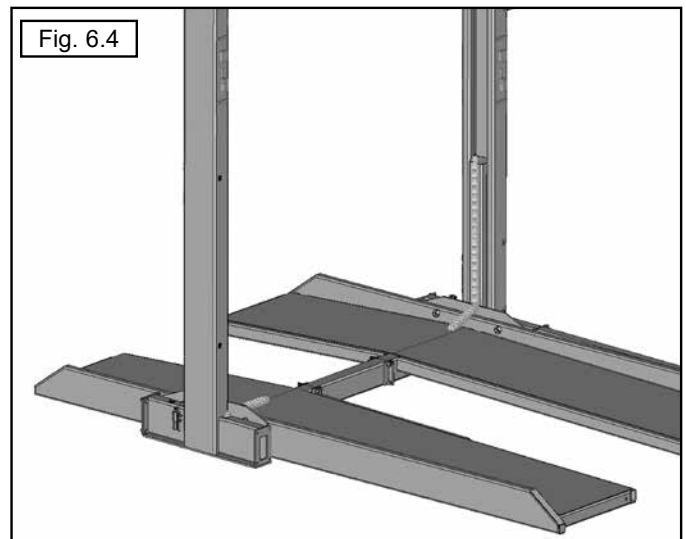
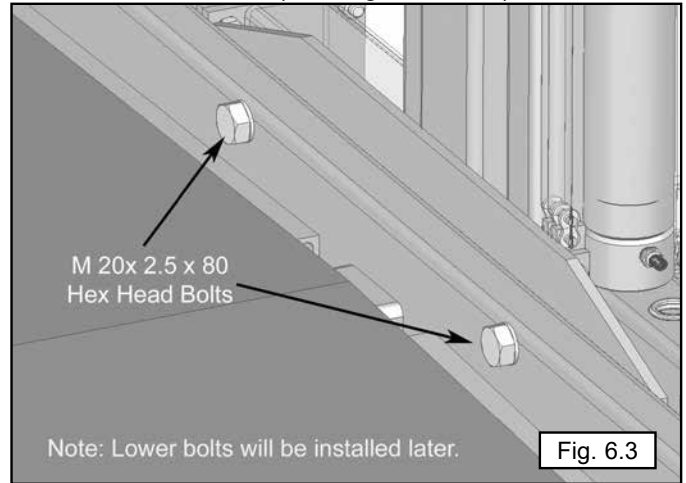

3. Repeat these steps for the Offside Column.

4. Install the Top Plates on each Column and route the Adjustable Chain Connector through the hole. Note: the Powerside Top Plate has the Hose Routing Clips. Secure the Adjustable Chain Connector using the 1-14 Nyloc Nut. (See Fig. 6.5)

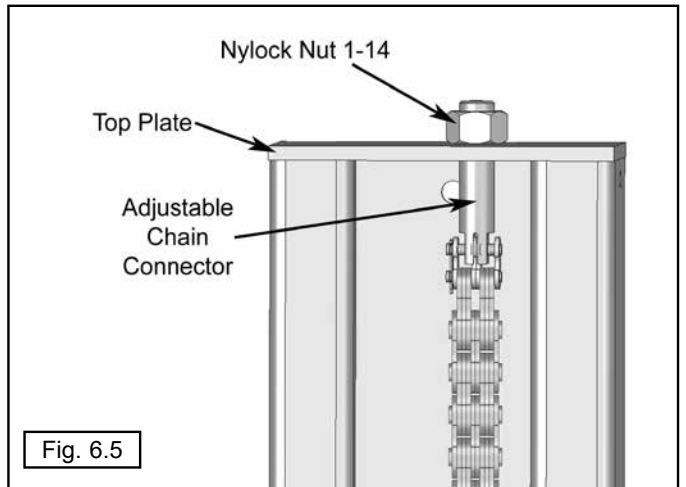

STEP 7

(Installing The Hydraulic Cylinders)

1. Position each Cylinder on top of the locating pin(s) at the front end of each Support-leg tube with the fitting port pointing in the direction of the Hydraulic Hose access hole. (See Fig. 7.1)

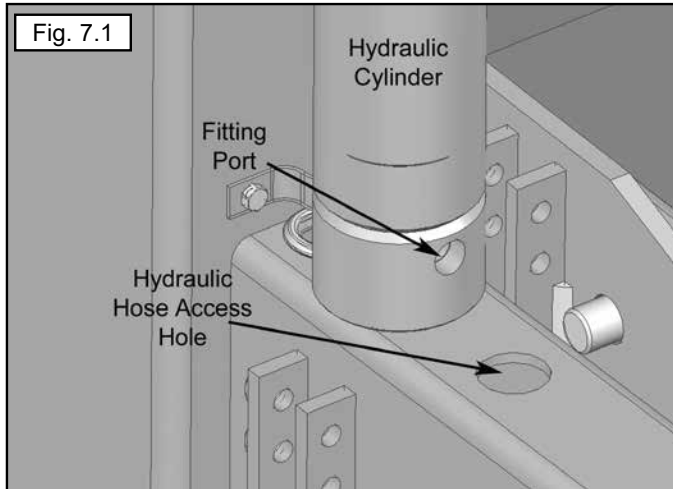

2. Install the Cylinder strap(s) as shown using four each M6 x 1 x 25 bolts and M6 Flat Washer. (See Fig. 7.2)

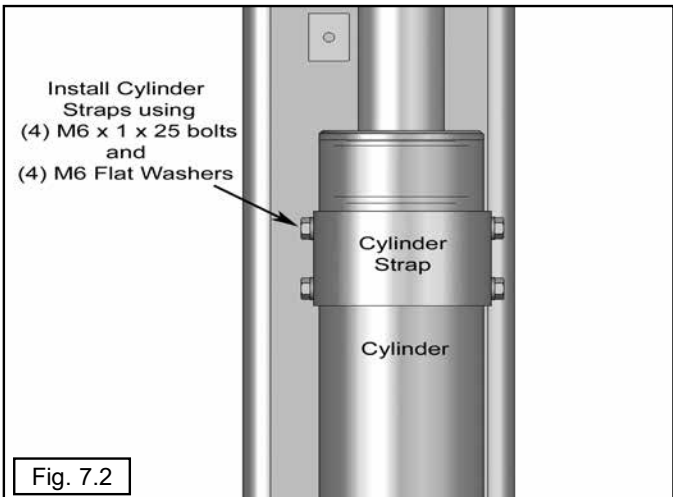

3. Install the Cylinder Roller on top of each Cylinder as shown. (See Fig. 7.3)

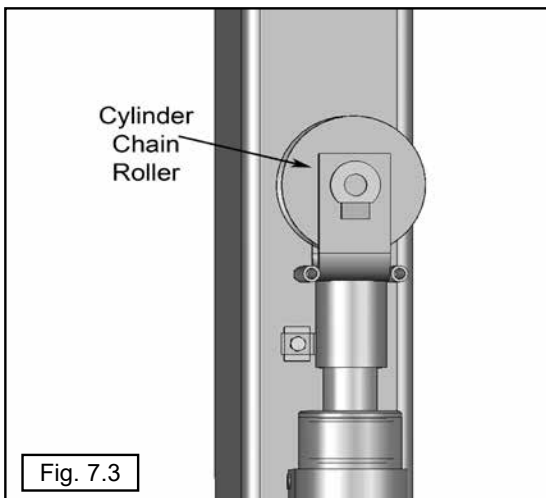

STEP 8

(Installing The Lifting Chain)

1. Route the Chain over the Cylinder Chain Roller and connect to the Bottom Chain Connector. (Fig. 8.1 & 8.2)

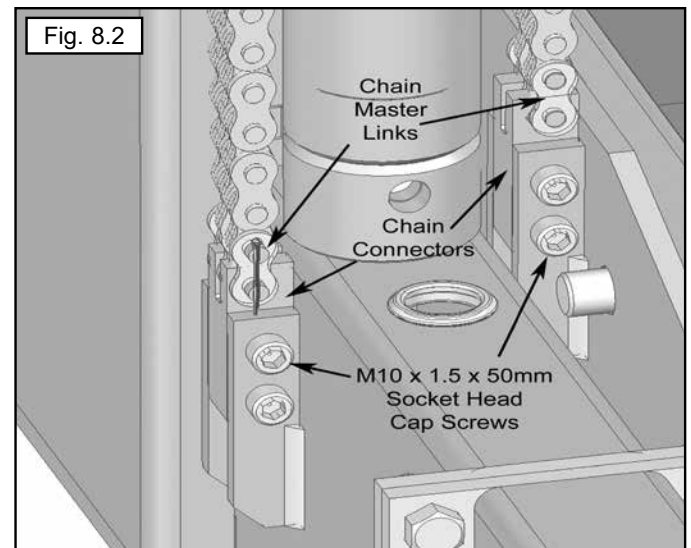
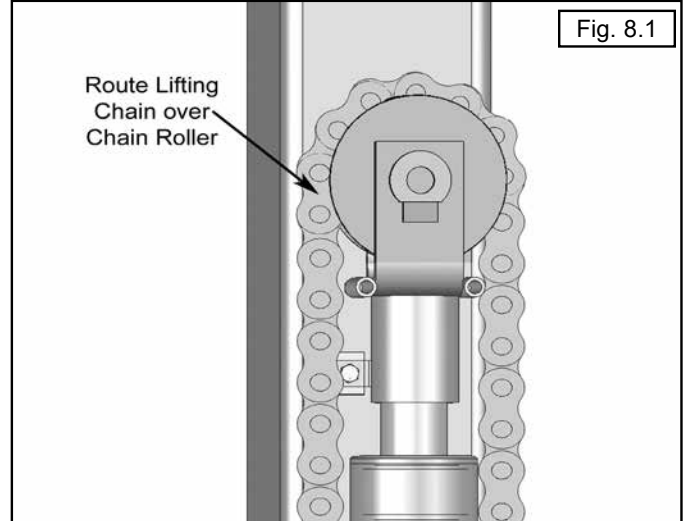

2. Install each Chain Roller Cover using M6 X 1.26 x 90 mm Hex Head Bolts, M6 Washers, and M6 Nyloc Nuts. (See Fig. 8.3)

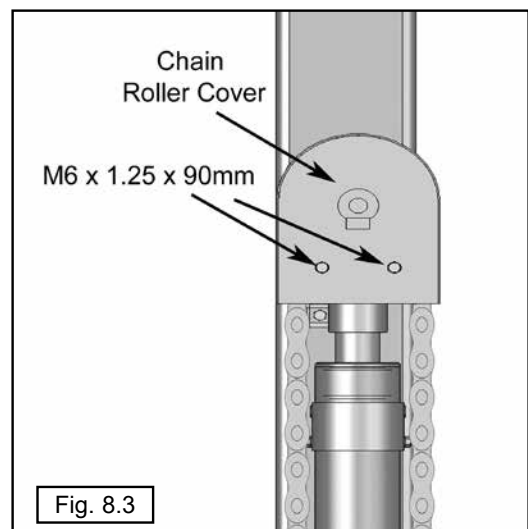

! DANGER

Pay careful attention when connecting Chains. Make sure that the Connecting Pins pass through **ALL** leaves in the Chain and through **ALL** sections of the Chain Connector. Failure to do so could cause lift failure resulting in personal injury or death. (See Fig. 8.4)

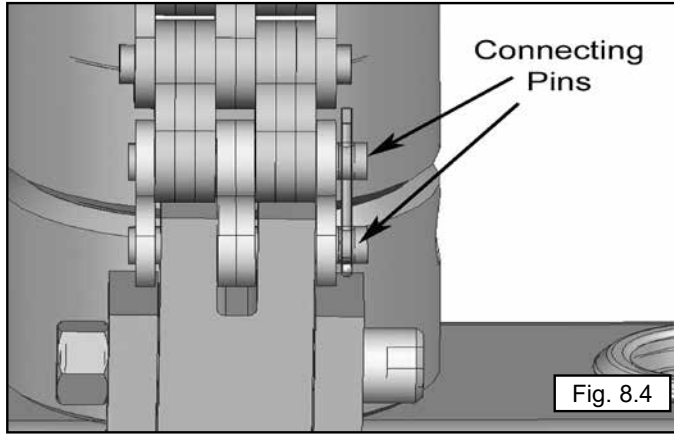

1. Position the Front Leg Support Tubes as shown but **DO NOT** bolt in position yet. The Hydraulic Hoses need to be routed prior to bolting in place. (See Fig. 10.1)

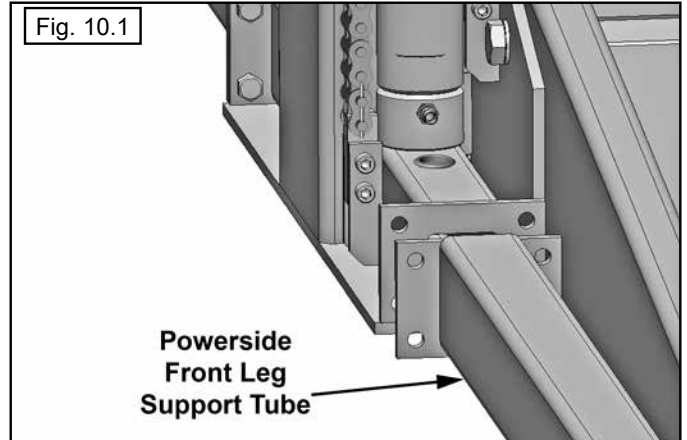

IMPORTANT NOTE:
On one side of the Front Leg Support Tube (at the end) there is a cutout and a bolt hole. This is where the Front Crossbar mounts to. Position the opening towards THE **INSIDE BOTTOM** of the lift. (See Fig. 10.2)

STEP 9

(Installing The Cylinder Fittings)

1. Install the Cylinder Fitting (with Thread Sealant on Cylinder side only) making sure that it is tightened inside the cylinder threads to prevent leakage. Install the 1-1/4" Rubber Grommet in the hose access hole as shown. (See Fig. 9.1)

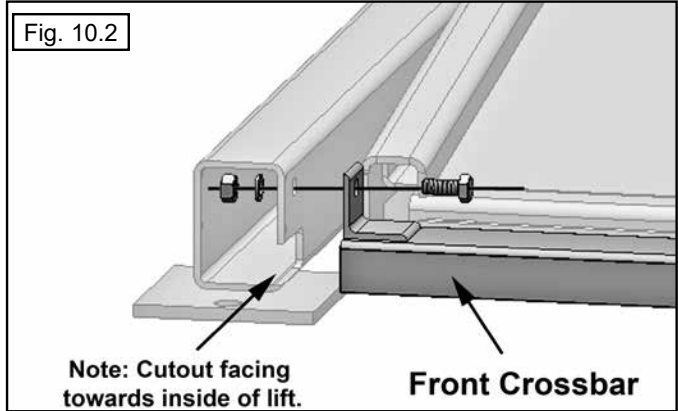
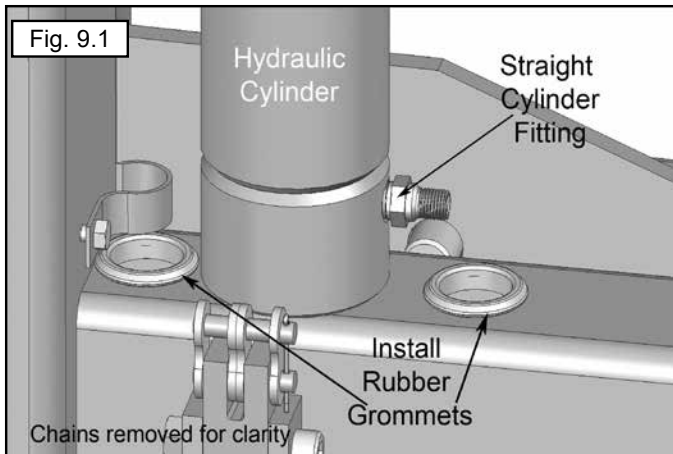

STEP 11

(Rear Support Tube Installation)

1. Bolt both Rear Support Tubes to Columns. (See Fig. 11.1)

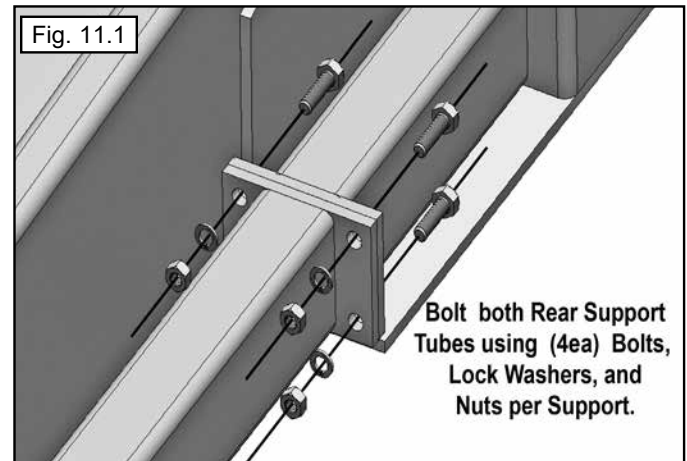

STEP 10

(Position The Front Support Leg Tubes and Front Crossbar)

NOTE:
Identify the Powerside and Offside Front Leg Support Tubes before proceeding. **DO NOT** Bolt components together until Hoses have been run through Support Tubes and Crossbar. Refer to Hose Routing diagrams in STEP 12.

STEP 12
(Routing The Hydraulic Hoses)

NOTE: Refer to Figures 12.1 - 12.6 for Hydraulic Hose routing.

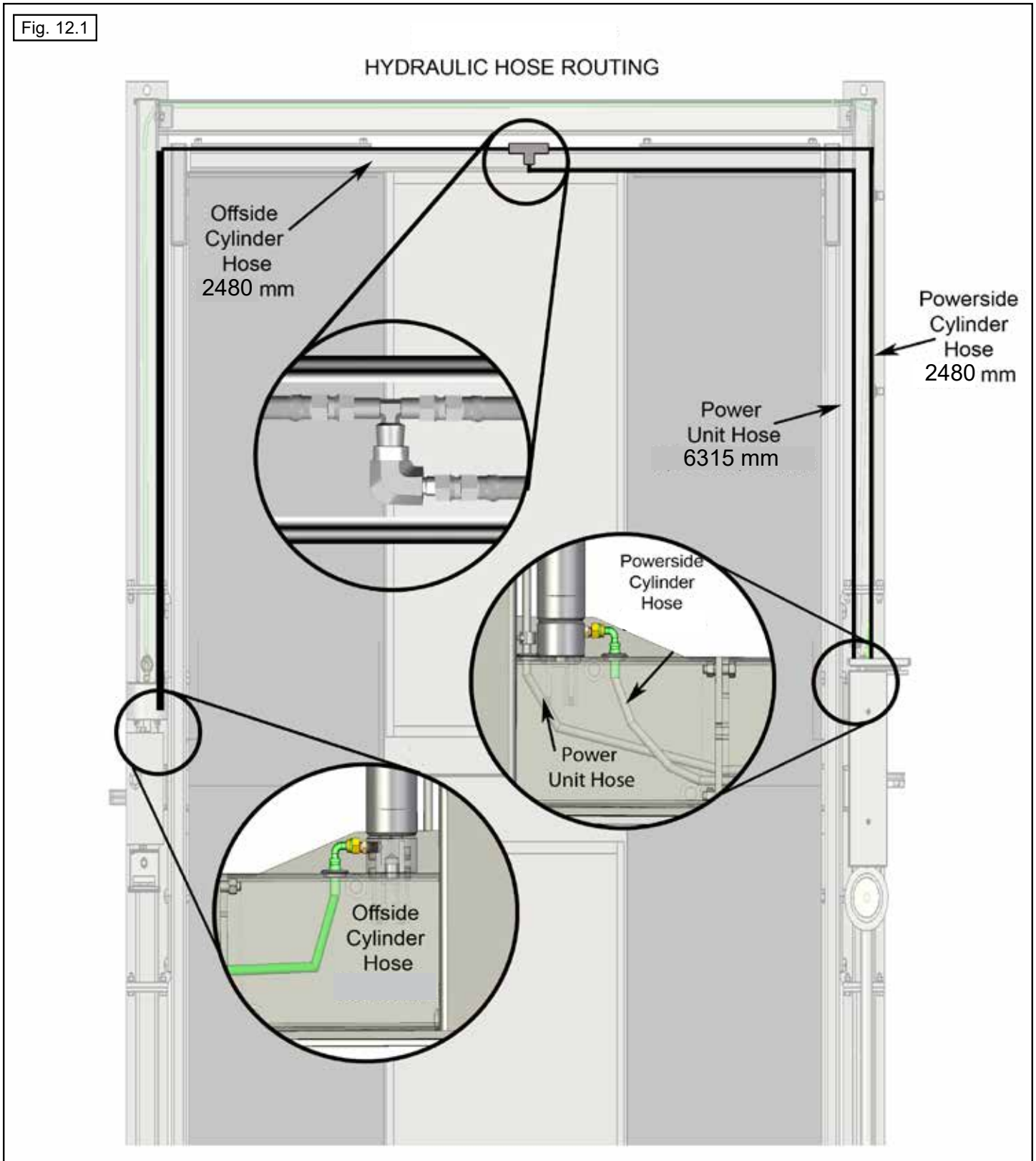

IMPORTANT NOTE:

The hydraulic hose **MUST** pass through the Front Support Legs on each column and under the Front Crossbar.

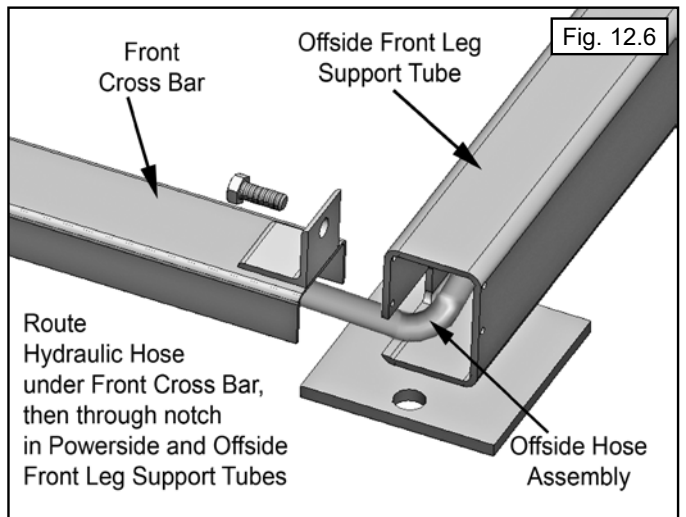
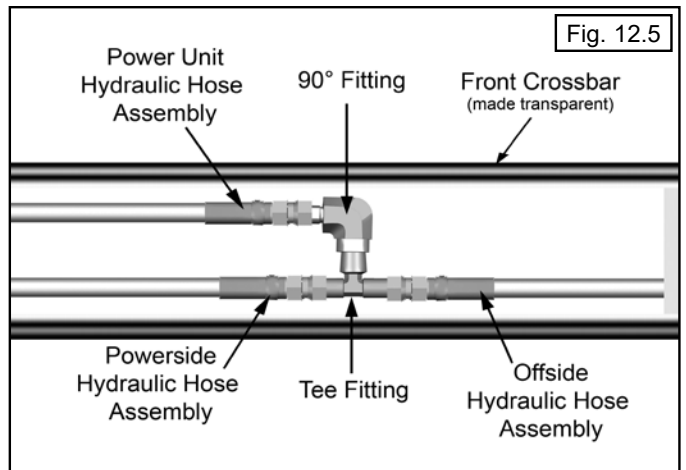
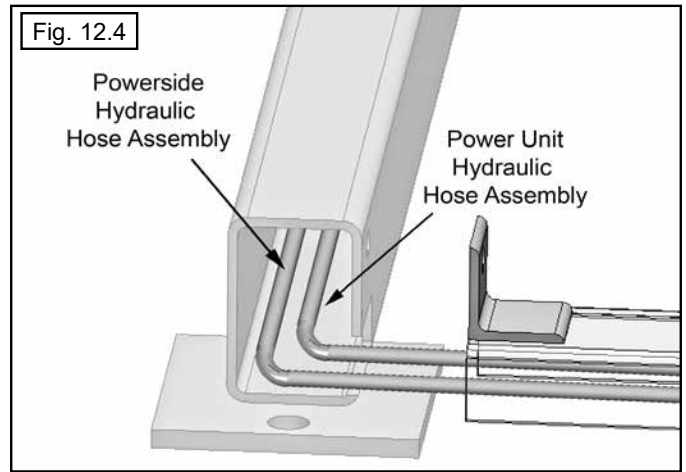
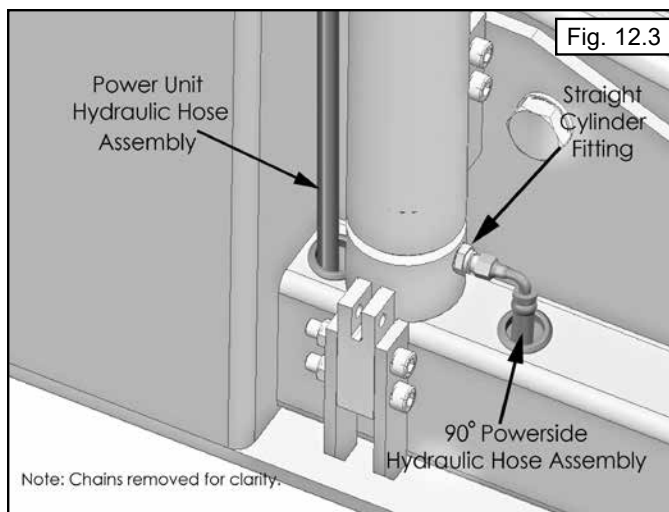
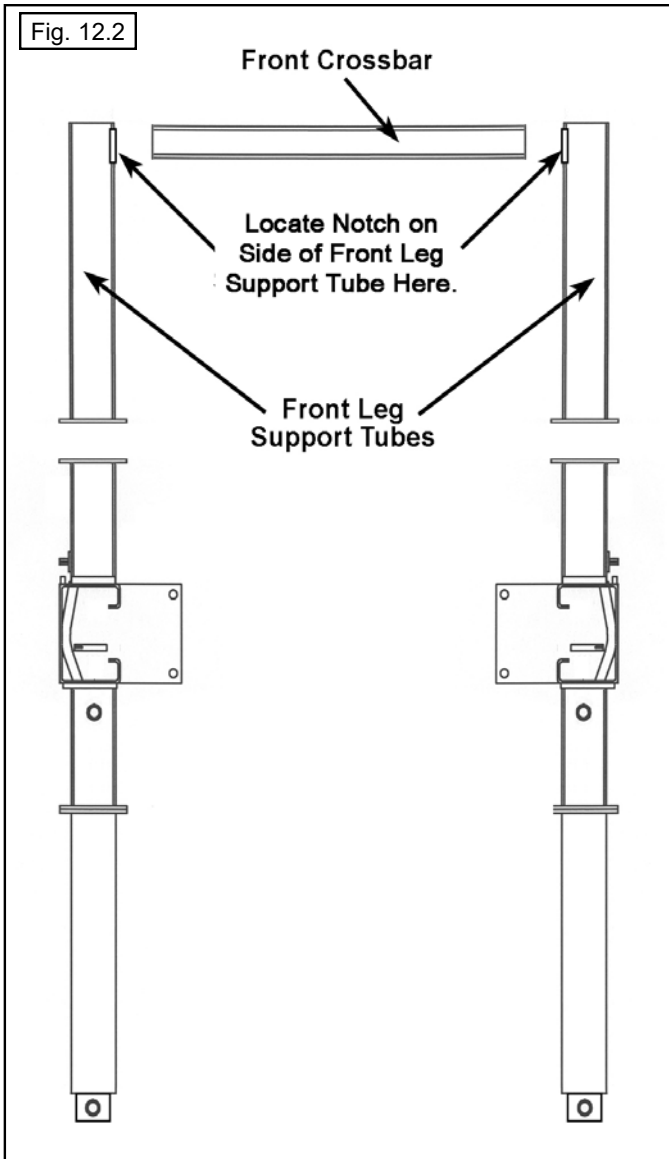

Tighten all bolts on Front Support tube assemblies at this time.

NOTE:

The End Caps of the Front Support Tubes should be installed after final inspections and checks are complete.

STEP 13
(Install Control Bar)

1. Bolt the Control Bar to the Powerside Column using the 4 Bolts and Lock Washers. (See Fig. 13.1)

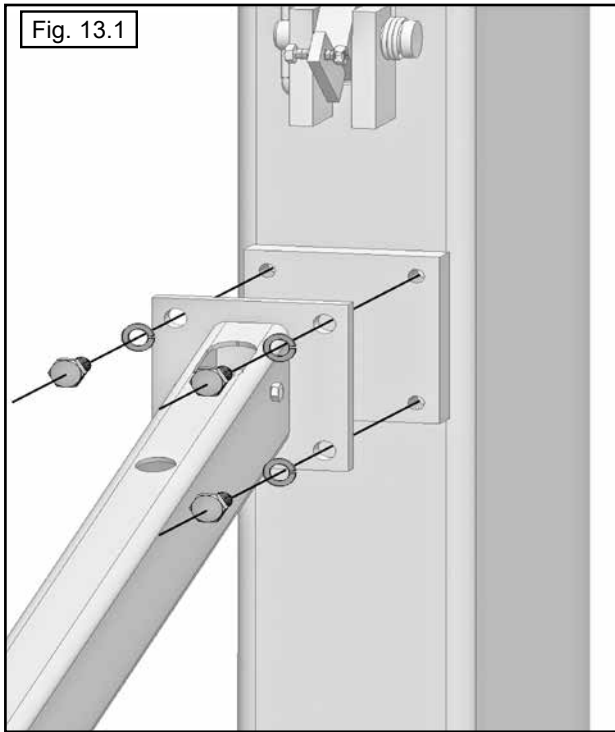

3. Route the Safety Cable through the Control Bar and bolt the Crimped End of the Safety Cable to the Safety using the Bolt and Nut. (See Fig. 14.2)

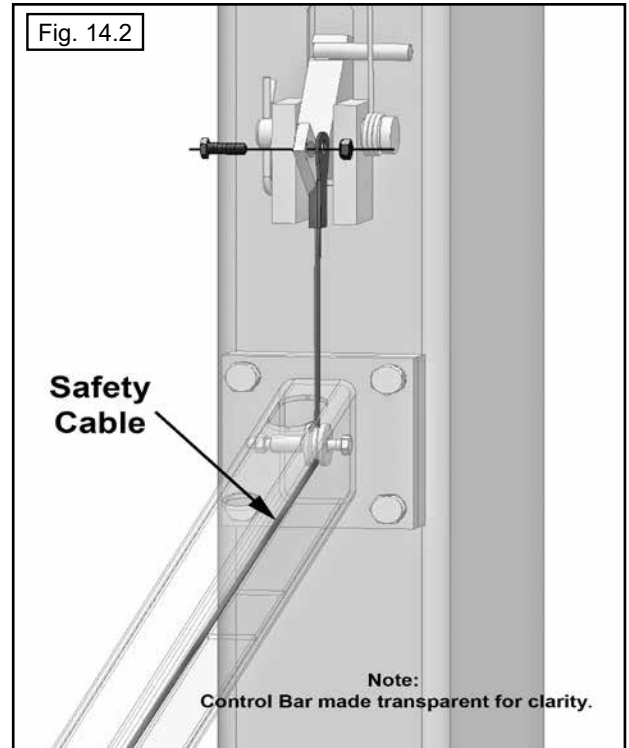

STEP 14
(Installing the Safety Lock Assembly)

2. Install the Safety Lock Assemblies, Safety Springs, 18mm Safety Lock Pivot Pin and Hairpin Clips on Powerside Column as shown. (See Fig. 14.1)

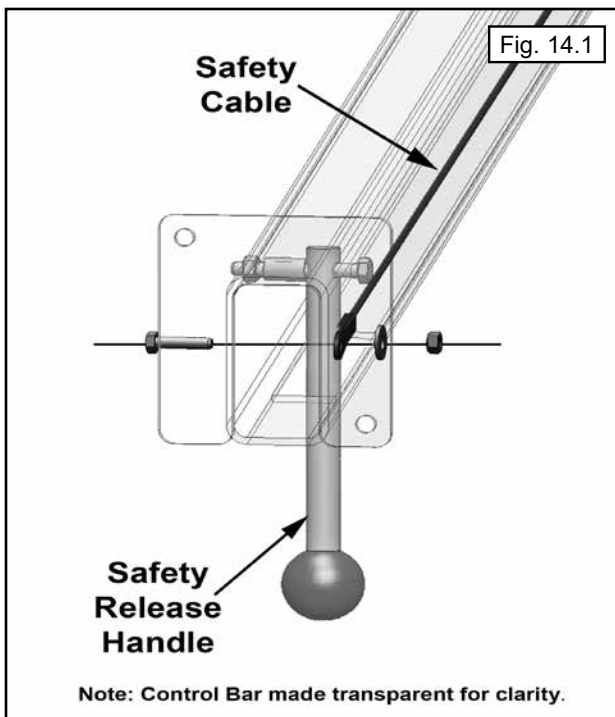

4. Route the other end of the Safety Cable down to the Safety Release Handle and Bolt the Crimped End to the Handle using the Bolt, Washer and Nut. (See Fig. 14.3)

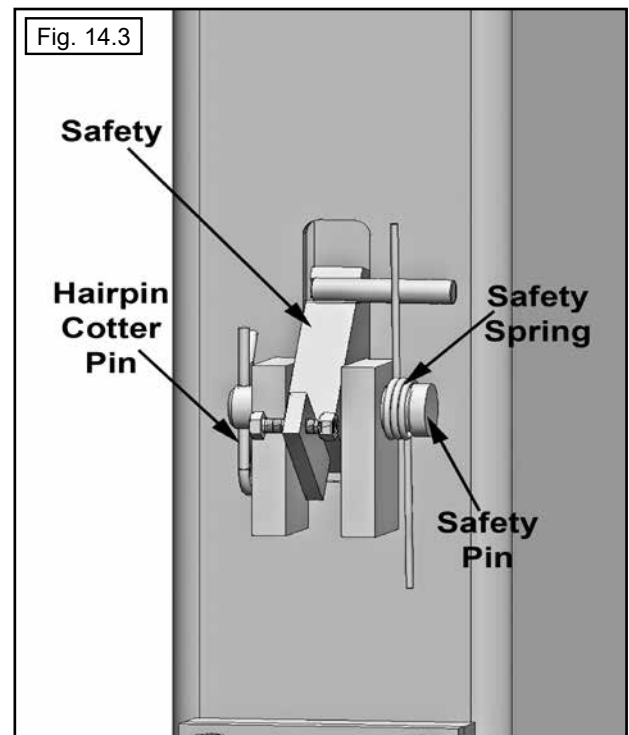

STEP 15

(Installing Key Switch and Power Cable)

NOTE:

REVIEW AND UNDERSTAND THE WIRING DIAGRAMS IN STEP 18 BEFORE PROCEEDING. THE ELECTRICAL WIRING DIAGRAMS OUTLINE HOW THE WIRES SHOULD BE RUN THROUGH THE CONTROL BAR. BE SURE YOU HAVE A THOROUGH UNDERSTANDING OF THE CABLE ROUTING BEFORE CUTTING ANY CABLES TO LENGTH.

1. Route the Power Cable through the Control Bar Tube. Install the Strain Relief in the hole in the Top of the Control Bar Leading up to the Power Unit. (See Fig. 15.1)

Note:

Route the Cable Straight through and out the access hole on the under side of the Control Bar; then install the Nut on the Strain Relief before routing the Cable through the Control Bar towards the Key Switch Box.

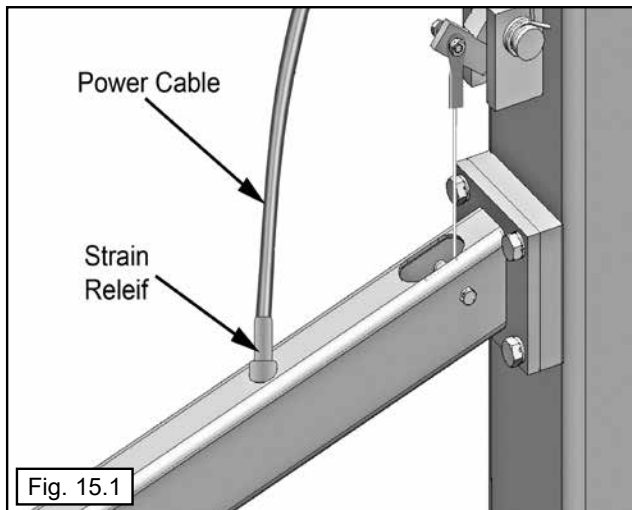

2. Route the Power Cable through the Control Bar to the Key Switch Box. Install the Strain Relief in the rear of the Key Switch Box. (See Fig. 15.2)

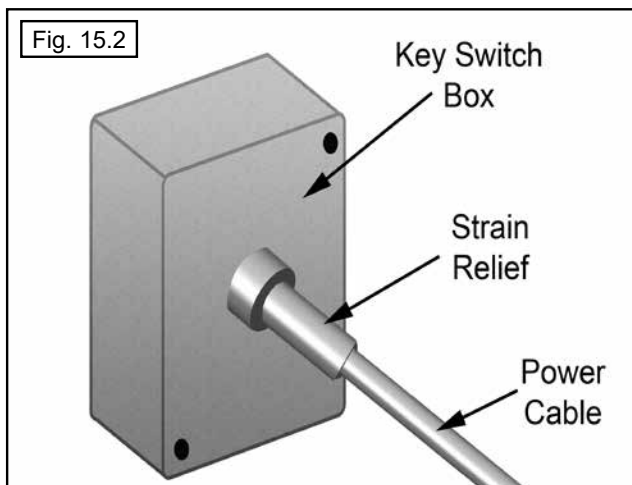

ALL WIRING MUST BE PERFORMED BY A LICENSED ELECTRICIAN.

3. Wire the Key Switch as shown in the Instructions and Wiring Diagrams on page 21 -25.
4. Mount the Key Switch Box on the Control Bar Assembly. (See Fig. 15.3)

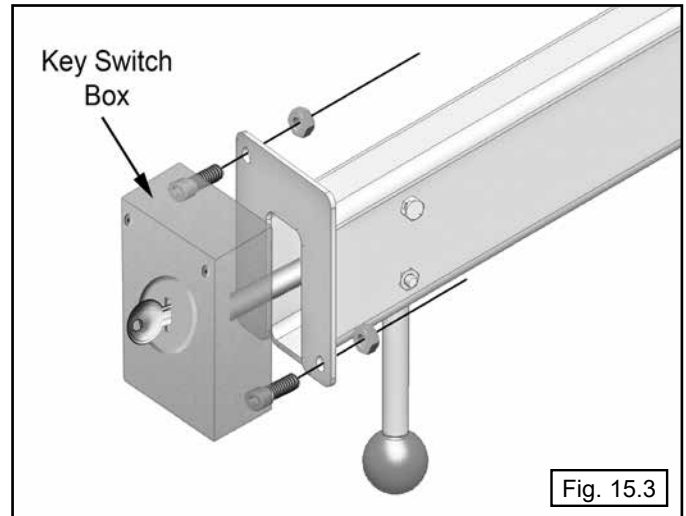

5. Attach the Safety/Operating Instruction Placard to the lower bolt of the Key Switch Box. (See Fig. 15.4)

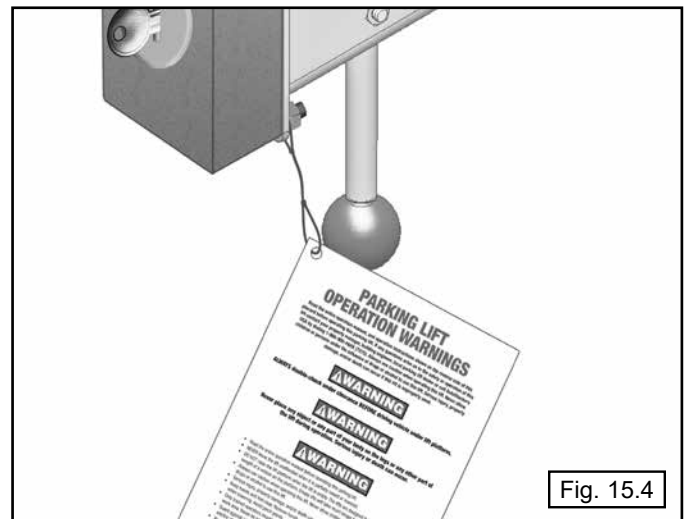

STEP 16

(Mounting the Hydraulic Power Unit)

1. Attach the Power Unit, Vibration Dampener and optional HPU Cover Bracket to the POWERSIDE COLUMN using four M8 hex bolts and nuts supplied. **Fill the reservoir with 10 WT. HYDRAULIC OIL or any approved ATF fluid such as: DEXRON TYPE III, DEXRON VI, MERCON V, or MERCON LV** / approximately four gallons. Make sure the funnel used to fill the reservoir is clean. (See Fig. 16.1)

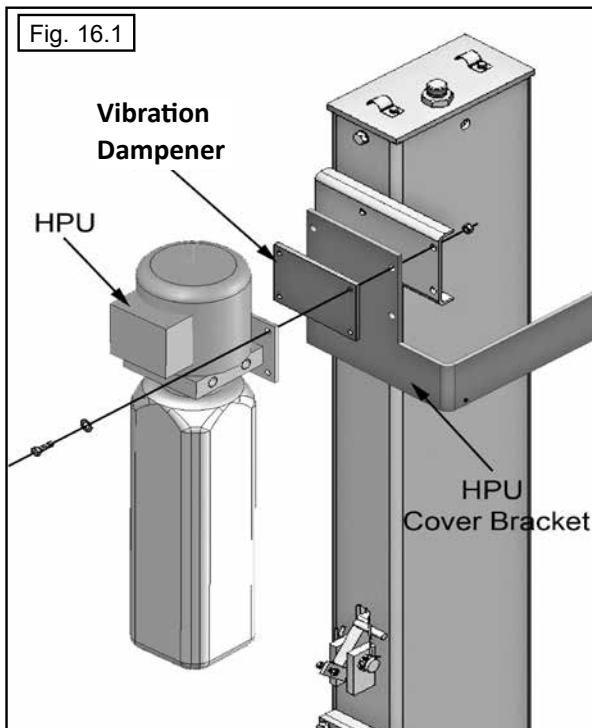

2. Remove plug from Power Unit and install the 90° Fitting w/ O-ring into the Power port on the Power Unit. (See Fig. 16.2)

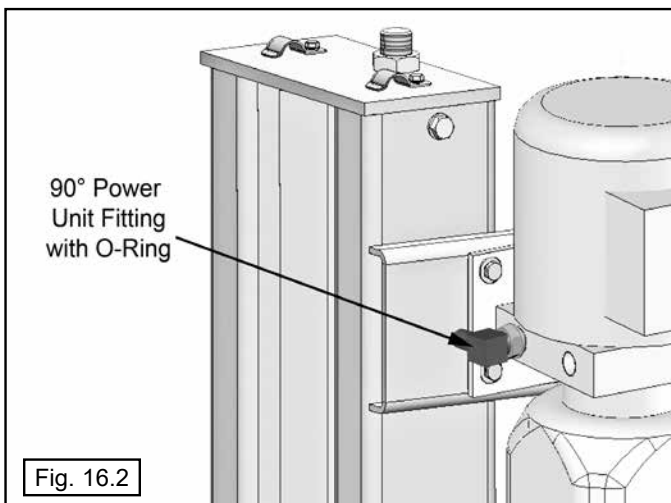

IMPORTANT NOTE:

Thread Sealant is not required when installing JIC Hydraulic fittings and hoses.

3. Connect the Power Unit Hose Assembly to the 90° Fitting. Route the Hose Through Clips on Top Plate and down the Column. (See Fig. 16.3)

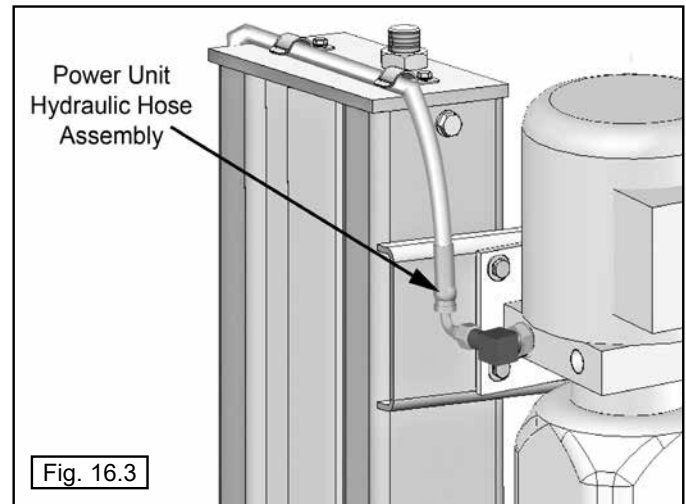

DANGER

ALL WIRING MUST BE PERFORMED BY A LICENSED ELECTRICIAN.

4. Route the Power Cable up to the Electrical box on the Power Unit and install the Strain Relief into bottom of the Electrical Box and route the Power Cable through the Strain Relief. (See Fig. 16.4)

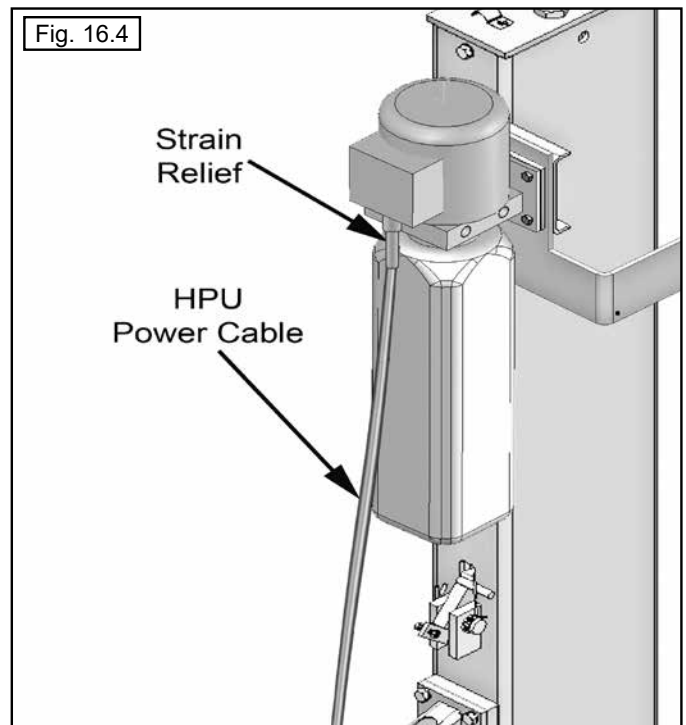

STEP 17
(Wiring the Power Unit)



DO NOT PERFORM ANY MAINTENANCE OR INSTALLATION OF ANY COMPONENTS WITHOUT FIRST ENSURING THAT ELECTRICAL POWER HAS BEEN DISCONNECTED AT THE SOURCE OR PANEL AND CANNOT BE RE-ENERGIZED UNTIL ALL MAINTENANCE AND/OR INSTALLATION PROCEDURES ARE COMPLETED.



ALL WIRING MUST BE PERFORMED BY A LICENSED ELECTRICIAN.

**NOTE:
REVIEW AND UNDERSTAND THE WIRING DIAGRAMS ON THE PAGES THAT FOLLOW BEFORE PROCEEDING. THE ELECTRICAL WIRING DIAGRAMS OUTLINE HOW THE CABLE SHOULD BE RUN THROUGH THE CONTROL BAR. BE SURE YOU HAVE A THOROUGH UNDERSTANDING OF THE WIRE ROUTING BEFORE CUTTING ANY CABLES TO LENGTH.**

3 Phase
 REVA 08-17-09

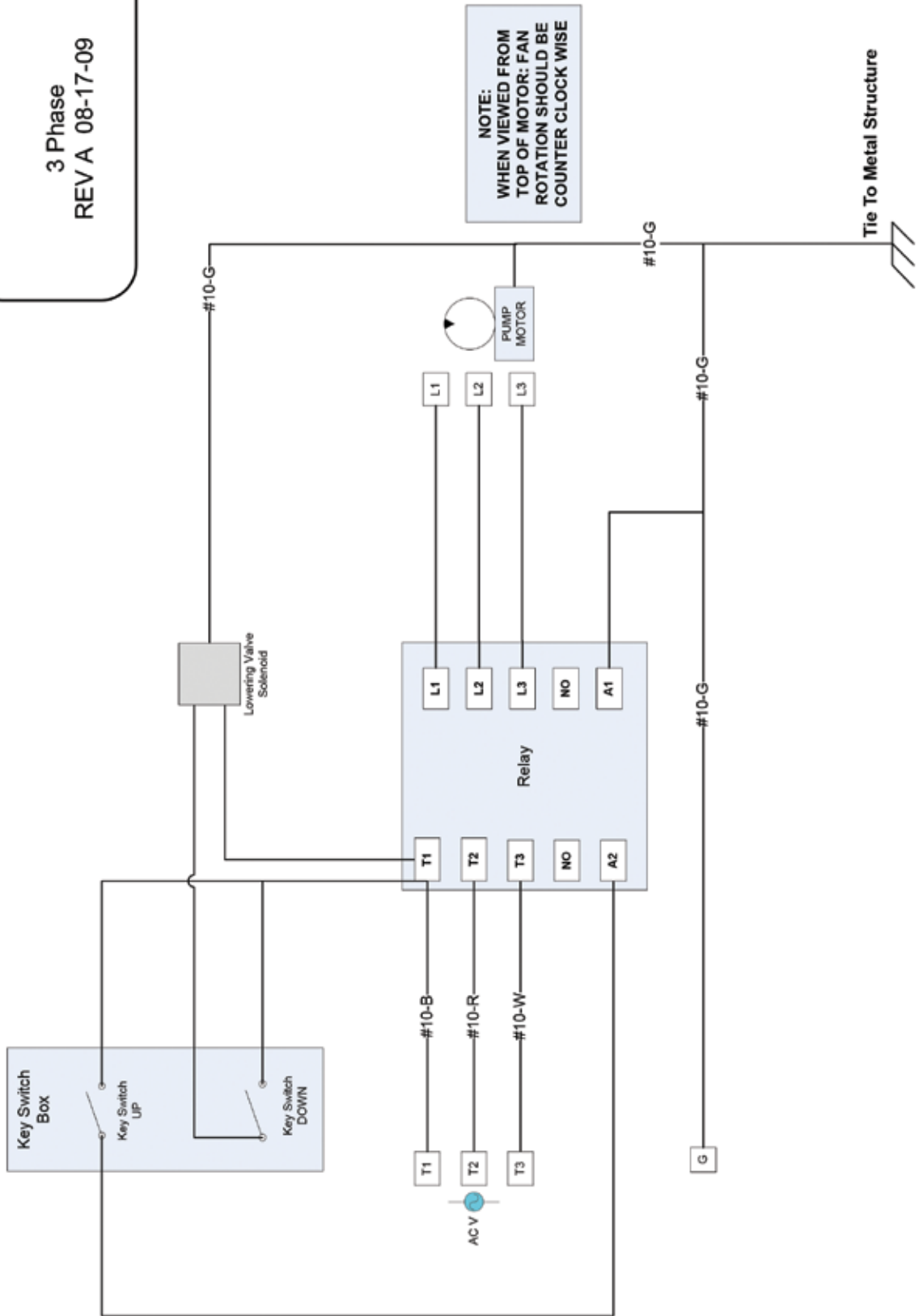

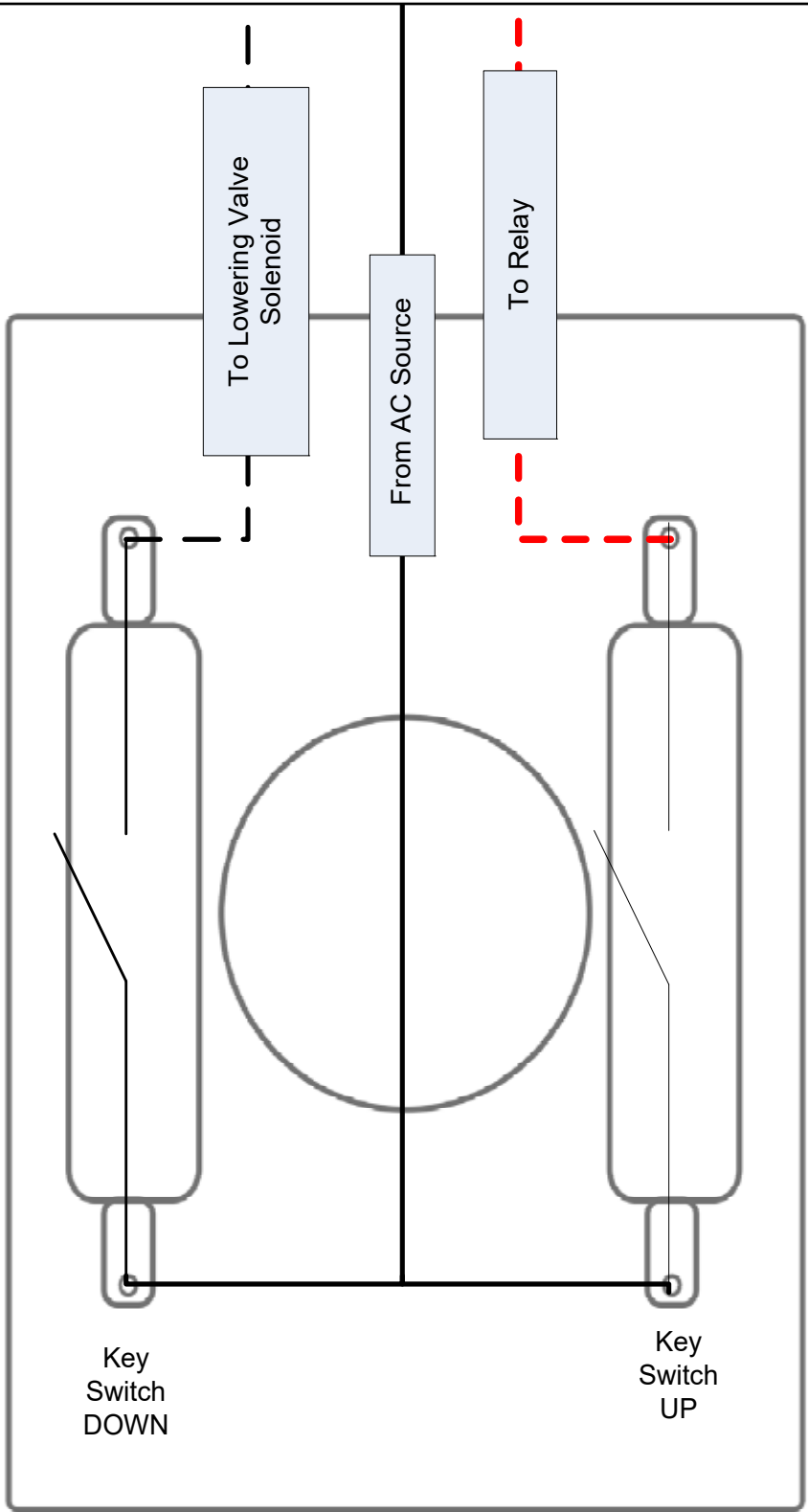

220V 1 Phase
REV A 08-17-09

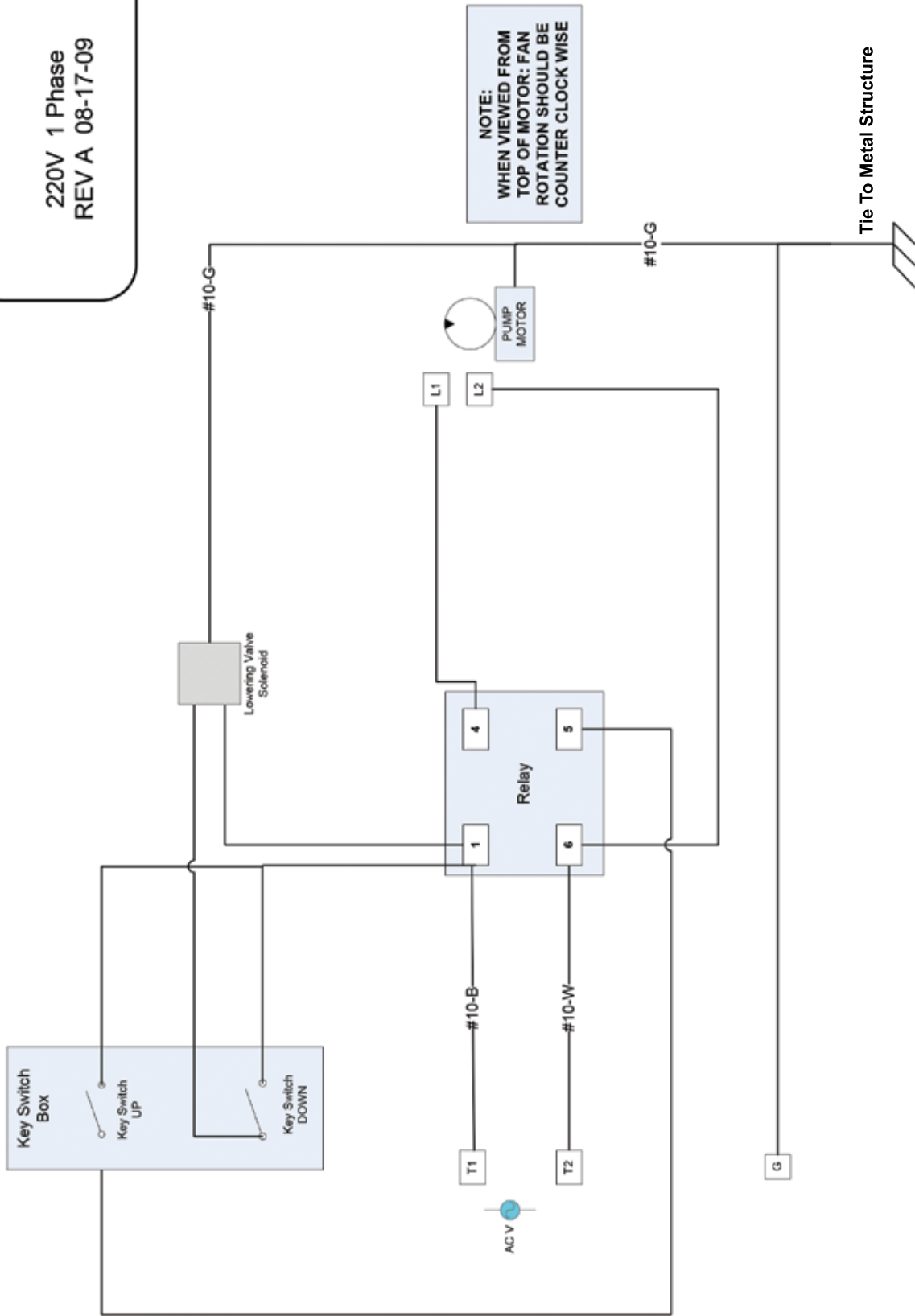



ALL WIRING MUST BE PERFORMED BY A LICENSED ELECTRICIAN.

The standard power unit for your lift is 220 volt, 60 HZ, single phase. All wiring must be performed by a licensed electrician only. SEE WIRING INSTRUCTIONS AFFIXED TO MOTOR FOR PROPER WIRING INSTRUCTIONS.

Have a licensed electrician run 208 - 230 volt single phase 60 HZ power supply to power unit. (If you ordered optional three phase power refer to the data plate found on the motor for proper power supply.) Be sure to size wire for a 25 amp circuit. This lift must be grounded while in use to protect the operator from electric shock. The power unit used on this lift contains high voltage. Disconnect power at the receptacle before performing any electrical repairs.

DO NOT PERFORM ANY MAINTENANCE OR INSTALLATION OF ANY COMPONENTS WITHOUT FIRST ENSURING THAT ELECTRICAL POWER HAS BEEN DISCONNECTED AT THE SOURCE OR PANEL AND CANNOT BE RE-ENERGIZED UNTIL ALL MAINTENANCE AND/OR INSTALLATION PROCEDURES ARE COMPLETED.



DO NOT run power unit with no oil. Damage to pump can occur. The power unit must be kept dry. Damage to power unit caused by water or other liquids such as detergents, acid etc., is not covered under warranty. Operate lift only between temperatures of 41 °- 104° F.

Improper electrical hook-up can damage motor and will not be covered under warranty. Motor can not run on 50HZ without a physical change to the motor.

Use a separate breaker for each power unit.

Protect each circuit with time delay fuse or circuit breaker.

*** For 208-230 volt, single phase, use a 25 amp fuse.**

*** For 208-230 volt, three phase, use a 20 amp fuse.**

*** For 380-440 volt, three phase, use a 15 amp fuse.**

SEE WIRING INSTRUCTIONS AFFIXED TO MOTOR FOR PROPER WIRING INSTRUCTIONS.

STEP 18

(Power Unit Hook Up)

1. Have a certified electrician run the power supply to motor. Refer to the data plate found on the motor for proper power supply and wire size.



RISK OF EXPLOSION!

This equipment has internal arcing or parts that may spark and should not be exposed to flammable vapors.

Motor should not be located in a recessed area or below floor level. NEVER expose motor to rain or other damp environments. **DAMAGE TO MOTOR CAUSED BY WATER IS NOT COVERED UNDER WARRANTY.**

IMPORTANT NOTE:

CAUTION Never operate the motor on line voltage less than 208 V. Motor damage may occur which is not covered under warranty. Have a certified electrician run appropriate power supply to motor. Size wire for 25 amp circuit. See Motor Operating Data Table.

IMPORTANT: Use separate circuit for each power unit.

Protect each circuit with time delay fuse or circuit breaker. For single phase 208-230 V, use 25 amp fuse. Three phase 208-240 V, use 25 amp fuse. For three phase 400 V and above, use 15 amp fuse. All wiring must comply with NECK and all local electrical codes.



During the START-UP procedure, observe all operating components and check for proper installation and adjustment. DO NOT attempt to raise vehicle until a thorough operational check has been completed.

STEP 19

(Final Adjustments)

1. Make sure the Power Unit reservoir is full with 12 quarts of 10-WT hydraulic oil or any approved ATF fluid such as: Dexron III, Dexron VI, Mercon V, Mercon LV or similar grade.
2. Spray the inside of the Columns where the Slide Blocks glide with a light lubricant or WD-40.
3. Test the Power Unit by pressing the push-button switch. If the motor sounds like it is operating properly, raise the lift and check all hose connections for leaks. If the motor gets hot or sounds peculiar, stop and check all electrical connections.

4. Before proceeding, double-check to make sure all Chains are properly positioned within the grooves of **ALL** Sheaves. Make sure all Chain, Sheave retaining pins and/or clips are secure.

5. Check to make sure that all Safety Locks are cleared and free.

6. Continue pressing the raise button until the Chains get taught and the lift starts to move.

7. **KEEP HANDS AND FEET CLEAR.** Remove hands and feet from any moving parts. Keep feet clear of lift when lowering. Avoid pinch points.

8. Check all **MAIN SAFETY LOCKS** to make sure they move freely and spring back to the lock position when released. Lubricate all **SAFETY PIVOT** points with WD-40 or equal.

9. Run the lift up and down a few times to insure that the locks are engaging uniformly and that the safety release mechanisms are functioning. Re-adjust if necessary.

STEP 20

(Lift Start Up)

1. Make sure the Power Unit reservoir is full with 12 quarts of 10-WT hydraulic oil or Dexron-III automatic transmission fluid.

2. Lubricate all friction points on the lift with a 90-WT Gear Oil.

3. Test the Power Unit by depressing the UP switch. If the motor sounds like it is operating properly, raise lift and check all hose connections for leaks. **IF MOTOR GETS HOT OR SOUNDS PECULIAR, STOP IMMEDIATELY AND RE-CHECK ELECTRICAL CONNECTIONS.**

4. Once the lift starts to raise, simultaneously press the Power Unit lowering handle at the same time you are pressing the raise button. This will allow any air trapped in the cylinders and lines to escape and vent into the fluid reservoir.



Because the lift is not raised high enough to reach the first safety lock position, **DO NOT** work on or near lift until support stands are in place to support the platform(s). Always ensure support stands and/or the safeties are engaged before any attempt is made to work on or near the lift / vehicle.

5. Raise the lift until it is approximately 36" off the ground. At this time place support stands under the platform(s) to safely support the lift during the following procedures(s).

STEP 21

(Attaching the Front and Rear Crossbars)



Because the lift is not raised high enough to reach the first safety lock position, **DO NOT** work on or near lift until support stands are in place to support the platform(s). Always ensure support stands and/or the safeties are engaged before any attempt is made to work on or near the lift / vehicle.

1. Attach the Front Crossbar and Tire stops as shown below using four M12 x 1.25 x 140 mm Hex Head Bolts, Spring Lock Washers and M12 x 1.5 Hex Nuts. (See Fig 21.1)

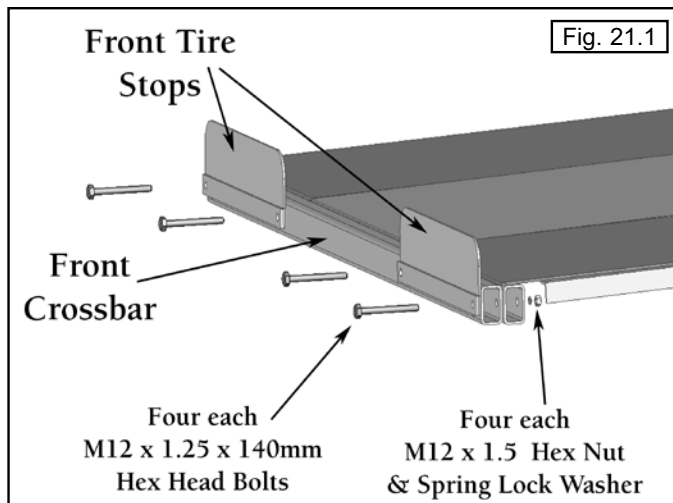

2. Install the Drive On Tire Stop Weldment with four M12 x 1.25 x 130 mm Hex Head Bolts, Spring Lock Washers and M12 x 1.5 Hex Nuts. (See Fig. 21.2)

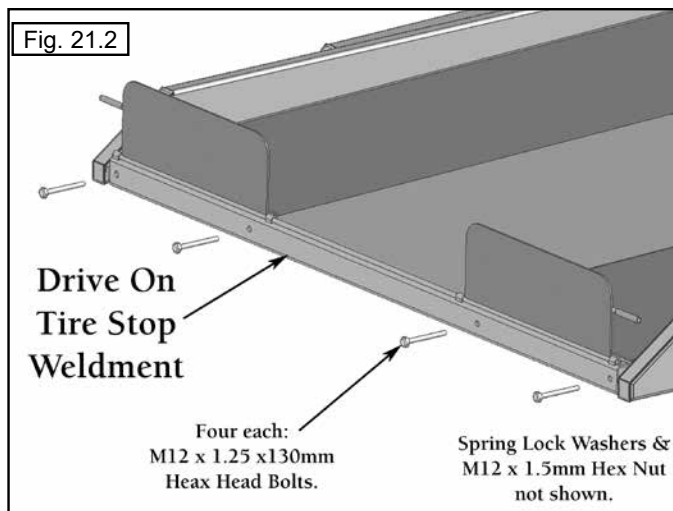

STEP 22

(Final Assembly)

1. Install the remaining M20 x 2.5 x 80 mm Hex Head Bolts to the underside of the lift platforms where the side rails of the decks attach to the lift carriage. (See Fig. 22.1)

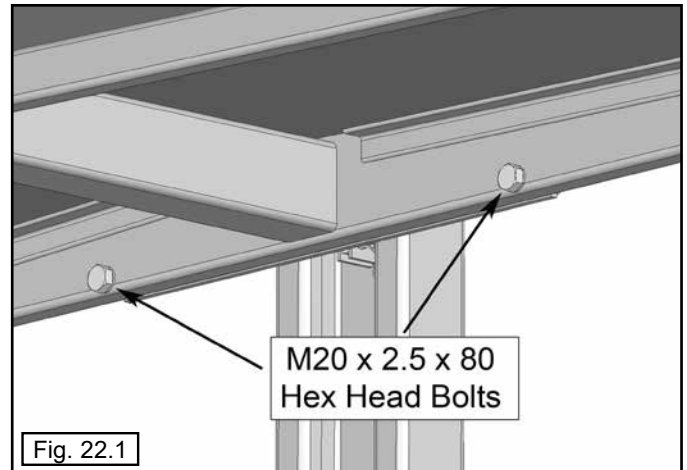

2. Tighten all platform bolts securely.
3. Tighten the Chain Adjusting Nuts on the top of each Column until the Chains are tight and equal tension. The Nyloc Cable Nuts **MUST** be tightened on each end until there is at least 1/4" of threads through the Nylon end of the nut. (See Fig. 22.2)

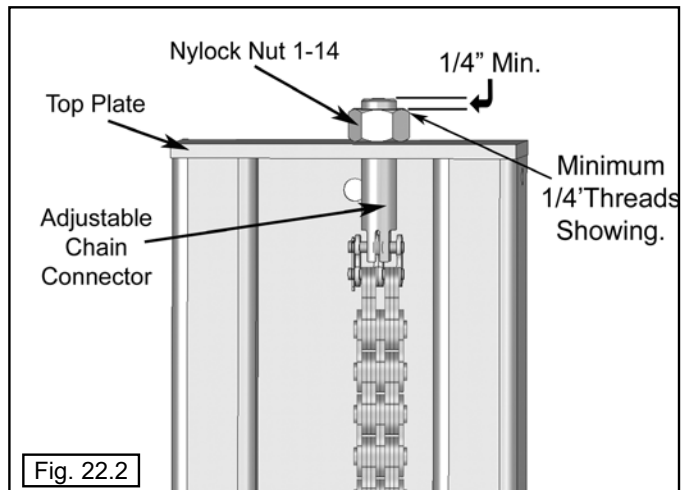

NOTE:

There will be some initial stretching of the chains in the beginning. It will be necessary to re-adjust the chains a week after first use, then every three to six months thereafter.

4. Run the lift up and down a few times to insure that the locks are engaging uniformly and that the safety release mechanisms are functioning properly. Re-adjust if necessary.

5. Install the HPU Cover after checking locks for proper operation. See Step 16, Fig. 16.5.

6. Install caps on end of Both Front Leg Support Tubes after inspecting Hydraulic Hose Connections for leaks. (See Fig. 22.3)

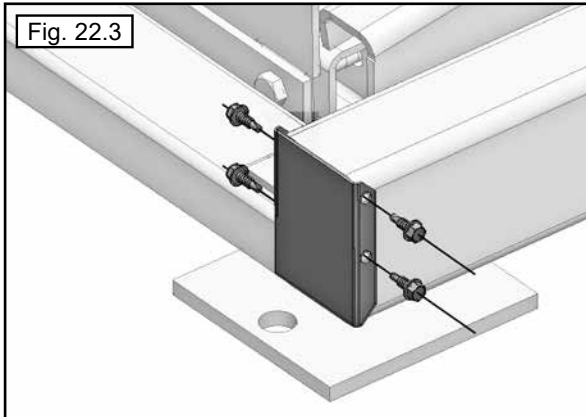

7. If installing multiple units, bolt Powerside and Offside Columns together using hole located at top of Columns. Some shims, washers or spacers may be required to keep Columns level. (See Fig. 22.4)

POST INSTALLATION CHECKLIST:

- ◆ Columns Properly Shimmed And Stable
- ◆ Anchor Bolts Tightened (If anchored)
- ◆ Pivot / Roller Pins Properly Attached
- ◆ Electric Power Supply Confirmed
- ◆ Chains Adjusted Properly
- ◆ Safety Locks Functioning Properly
- ◆ Check For Hydraulic Leaks
- ◆ Oil Level
- ◆ Lubrication of Critical Components
- ◆ Check For Overhead Obstructions
- ◆ Platforms Level
- ◆ All Screws, Bolts, and Pins Secured
- ◆ Surrounding Area Clean
- ◆ Operation, Maintenance and Safety Manuals on Site

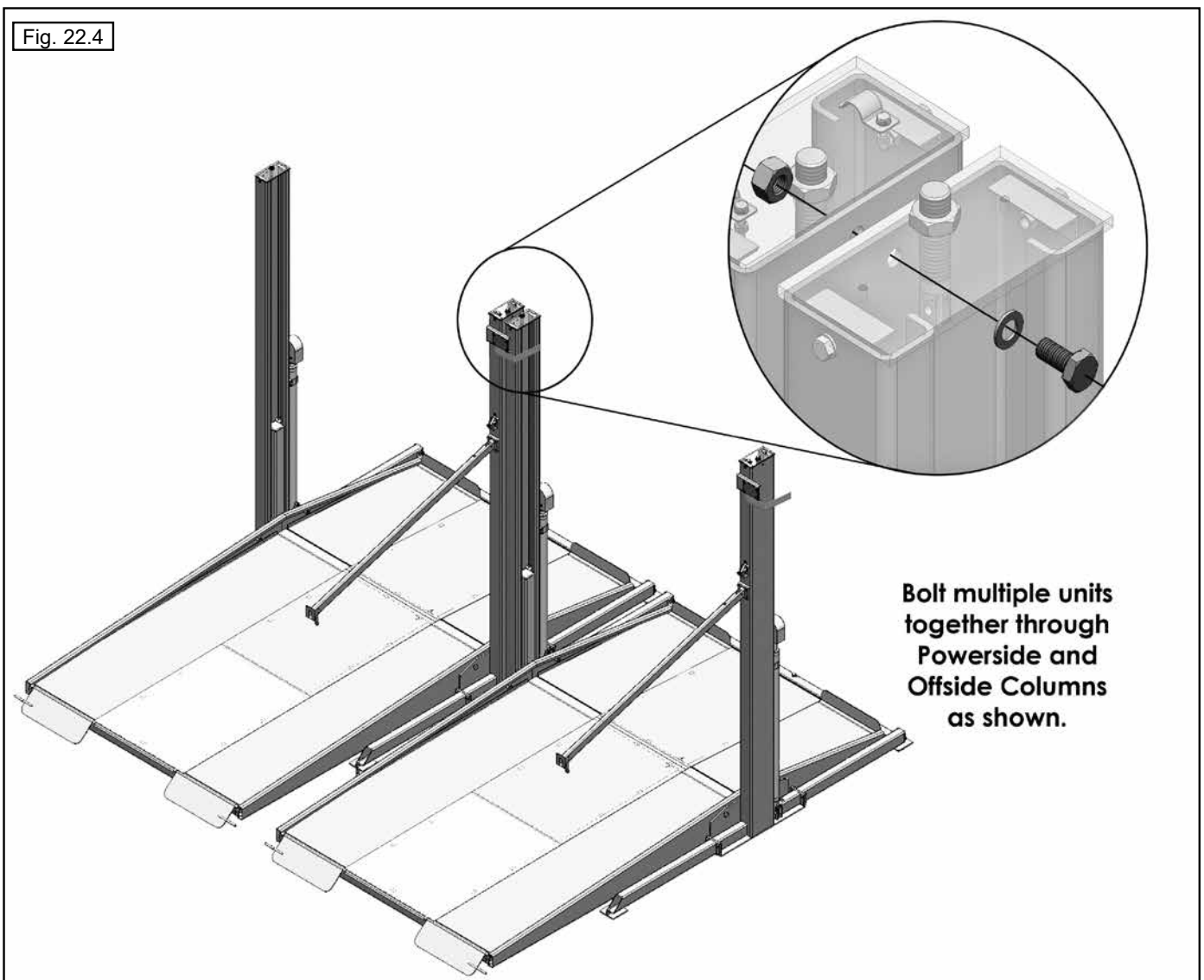

Bolt multiple units together through Powerside and Offside Columns as shown.

STEP 23

(Operation)

To Raise Lift:

1. Load vehicle onto the lift as far forward on the lift as possible.
2. Set parking brake and wheel chock to hold vehicle in position.
3. Before raising vehicle, be sure all personnel are clear of the lift and surrounding area. Pay careful attention to overhead clearances.
4. Raise the lift to the Safety Lock height by pressing the push button on the power unit.



VISUALLY CONFIRM THAT ALL PRIMARY SAFETY LOCKS ARE ENGAGED BEFORE ENTERING WORK AREA.

Suspension components on this lift are intended to raise and lower lift only and are not meant to be load holding devices.

Remain clear of elevated lift unless visual confirmation is made that all primary safety locks are fully engaged and the lift is **LOWERED** onto the safety locks. Refer to installation / operation manual for proper safety lock procedures and /or further instruction.

5. After vehicle is raised to the Safety Lock height, **lower the lift onto the safety lock.** Do not allow lifting chains to become slack. **ALWAYS INSURE ALL SAFETY LOCKS ARE ENGAGED** before entering work area.

To Lower Lift:

1. Before lowering vehicle, be sure all personnel are clear of the lift and surrounding area. Pay careful attention to overhead clearances. Insure all tools and equipment have been cleared from under the lift.



2. Raise the lift off of the safety locks by pressing the push button on the power unit. Make sure you raise the lift by at least two inches to allow adequate clearance for the locks to clear.

3. Press the Safety Release Button and HOLD.
4. Push the DOWN BUTTON on the power unit until the lift has descended completely.

When lowering the lift **PAY CAREFUL ATTENTION** that all personnel and objects are kept clear. **ALWAYS** keep a visual line of site on the lift **AT ALL TIMES. ALWAYS** make sure that **ALL LOCKS** are disengaged. If one of the locks inadvertently locks on descent the lift and/or vehicle may disrupt causing personal injury or death.

WEEKLY MAINTENANCE

1. Lubricate all rollers with general purpose oil or WD-40.
2. Check all chain connections, bolts and pins to insure proper mounting.
3. Lubricate safety lock pivot points with general purpose oil or WD-40.

MONTHLY MAINTENANCE

1. Check safety locks to insure they are in good operating condition.
2. Check all chains for excessive signs of wear.
3. Make a visual inspection of **ALL MOVING PARTS** and check for excessive signs of wear.
4. Replace ALL FAULTY PARTS **before** lift is put back into operation.



- ◆ **NEVER EXCEED THE RATED CAPACITY** of lift.
- ◆ **DO NOT USE LIFT** if any component is found to be defective or worn.
- ◆ **NEVER OPERATE LIFT** with any person or equipment below.
- ◆ **ALWAYS STAND CLEAR** of lift when lowering or raising.
- ◆ **ALWAYS INSURE SAFETY LOCKS ARE ENGAGED** before entering work area.
- ◆ **NEVER LEAVE LIFT IN ELEVATED CONDITION** unless all safety locks are engaged.

TO RAISE LIFT

- ◆ Read operating and Safety manuals before using lift.
- ◆ Always lift a vehicle according to the manufacturer's recommended lifting points.
- ◆ Position vehicle between columns.
- ◆ Raise the vehicle by depressing button until the vehicle just lifts off the ground. Recheck to make sure the vehicle is secure and all locking pins are lock in place.
- ◆ Raise vehicle to desired height. Lower vehicle onto nearest safety.
- ◆ Always ensure safeties are engaged before any attempt is made to work on or near vehicle.

TO LOWER THE LIFT

- ◆ First raise the lift to clear the safeties.
- ◆ Release safeties by pressing the Safety Release Button.
- ◆ Be sure tool trays, stands or personnel are cleared from under the vehicle.
- ◆ Lower vehicle by pressing Down Button on Control Pendant.
- ◆ Before removing vehicle from lift; clear any wheel chocks to provide an unobstructed exit.

- ◆ Check all chains connections, bolts and pins to insure proper mounting and torque.
- ◆ Visually inspect safeties for proper operation.
- ◆ Lubricate columns with grease.
- ◆ Inspect all anchors bolts and retighten if necessary.
- ◆ Check all columns for squareness and plumb.
- ◆ Inspect all electrical wiring for proper routing and clearance and connections.
- ◆ Check equalizer chain tension, and adjust if necessary.
- ◆ If lift is equipped with over head cut-off switch, check for proper operation.



1. **WARNING:** If cement anchor bolts are loose or any component of the lift is found to be defective, **DO NOT USE THE LIFT!!**
2. Never operate the lift with any person or equipment below the vehicle.
3. Never exceed the rated lift capacity.
4. Always insure the safeties are engaged before any attempt is made to work on or near the vehicle.
5. Never leave lift in elevated position unless the safeties are engaged.
6. Do not permit electric motor to get wet! Motor damage caused by dampness is not covered under warranty.

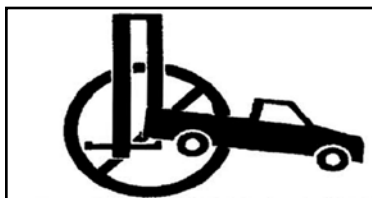

NEVER LIFT ANY VEHICLE IN ANY MANNER WITH LESS THE ALL FOUR WHEELS PROPERLY POSITIONED ON THE RAMPS.

Safe Lift Operation

Automotive and truck lifts are critical to the operation and profitability of your business. The safe use of this and other lifts in your shop is critical in preventing employee injuries and damage to customer's vehicles. By operating lifts safely you can insure that your shop is profitable, productive and safe.

Safe operation of automotive lifts requires that only trained employees should be allowed to use the lift.

TRAINING SHOULD INCLUDE, BUT NOT LIMITED TO:

- ◆ Proper positioning of the vehicle on the runway. (See manufacturer's minimum wheel base loading requirements.)
- ◆ Use of the operating controls.
- ◆ Understanding the lift capacity.
- ◆ Proper use of jack stands or other load supporting devices.
- ◆ Proper use, understanding and visual identification of safety lock devices and their operation.
- ◆ Reviewing the safety rules.
- ◆ Proper housekeeping procedures (lift area should be free of grease, oil, tools, equipment, trash, and other debris)
- ◆ A daily inspection of the lift should be completed prior to its use. Safety devices, operating controls, lift arms and other critical parts should be inspected prior to using the lift.
- ◆ All maintenance and repairs of the lift should be completed by following the manufacturer's requirements. Lift repair parts should meet or exceed OEM specifications. Repairs should only be completed by a qualified lift technician.
- ◆ The vehicle manufacturer's recommendations should be used for spotting and lifting the vehicle.

LIFT OPERATION SAFETY

- ◆ It is important that you know the load limit. Be careful that you do not overload the lift . If you are unsure what the load limit is, check the data plate found on one of the lift columns or contact the manufacturer.
- ◆ The center of gravity should be followed closely to what the manufacturer recommends.
- ◆ Always make sure you have proper overhead clearance. Additionally, check that attachments (vehicle signs, campers antennas, etc.) are not in the way.
- ◆ Be sure that prior to the vehicle being raised, the doors, trunk, and hood are closed securely.
- ◆ Prior to being raised, make sure there is no one standing closer than six feet from the lift.
- ◆ After positioning the vehicle on the lift runways, set the emergency brake, make sure the ignition is off, the doors are closed, overhead obstructions are cleared, and the transmission is in neutral.
- ◆ Double check that the automatic chock devices are in position and then when the lift is raised, observe the chocks.
- ◆ Put pads or adapters in the right position under the contact points that have been recommended.
- ◆ The lift should be raised just until the vehicle's wheels are about one foot off the ground. If contact with the vehicle is uneven or it appears that the vehicle is not sitting secure, carefully lower the lift and readjust.
- ◆ Always consider potential problems that might cause a vehicle to slip, i.e., heavy cargo, undercoating, etc.
- ◆ Pay attention when walking under a vehicle that is up on the hydraulic lift.



- ◆ **DO NOT** leave the controls while the lift is still in motion.
- ◆ **DO NOT** stand directly in front of the vehicle or in the bay when vehicle is being loaded or driven into position.
- ◆ **DO NOT** go near vehicle or attempt to work on the vehicle when being raised or lowered.
- ◆ **REMAIN CLEAR** of lift when raising or lowering vehicle.
- ◆ **DO NOT** rock the vehicle while on the lift or remove any heavy items that may cause excessive weight shift.
- ◆ **DO NOT** lower the vehicle until people, materials, and tools are clear.
- ◆ **ALWAYS INSURE** that the safeties are engaged and lowered on to the safety stops before any attempt is made to work on or near vehicle.
- ◆ Some vehicle maintenance and repair activities may cause the vehicle to shift. Follow the manufacturer's guidelines when performing these operations. The use of jack stands or alternate lift points may be required when completing some repairs.
- ◆ **READ AND UNDERSTAND** all safety warning procedures before operating lift.
- ◆ **KEEP HANDS AND FEET CLEAR.** Remove hands and feet from any moving parts. Keep feet clear of lift when lowering. Avoid pinch points.
- ◆ **ONLY TRAINED OPERATORS** should operate this lift. All non-trained personnel should be kept away from work area. Never let non-trained personnel come in contact with, or operate lift.
- ◆ **USE LIFT CORRECTLY.** Use lift in the proper manner. Never use lifting adapters other than what is approved by the manufacturer.
- ◆ **DO NOT** override self-closing lift controls.
- ◆ **CLEAR AREA** if vehicle is in danger of falling.
- ◆ **STAY ALERT.** Watch what you are doing. Use common sense. Be aware.
- ◆ **CHECK FOR DAMAGED PARTS.** Check for alignment of moving parts, breakage of parts or any condition that may affect its operation. Do not use lift if any component is broken or damaged.
- ◆ **NEVER** remove safety related components from the lift. Do not use lift if safety related components are damaged or missing.
- ◆ When the lift is being lowered, make sure everyone is standing at least 10 feet away.
- ◆ Be sure there are no jacks, tools, equipment, left under the lift before lowering.
- ◆ Always lower the vehicle slowly and smoothly.
- ◆ In secured areas such as valet, the parking lift must only be operated by trained individuals.
- ◆ The boundaries of the lift shall be marked on the ground with contrasting color lines that clearly indicate the areas of operation.

LIFT OPERATION TRAINING

- ◆ All lift operators must receive at least one of the following types of training:
 - LMS online training.
 - Training at the manufacturer's facility.
 - Training by a manufacturer's representative on the customer site.

LIFT OPERATION DURING ABNORMAL CONDITIONS OR EMERGENCIES

- ◆ Due to risk of severe injury or death, in case of power failure or power outage, do not attempt to operate the lift or bring a lifted vehicle back down to the ground. Instead, wait until the power problem is resolved; if there is a problem after power has been restored, contact BendPak Customer Service at (805) 933-9970 and request a qualified service technician visit to repair the lift.
- ◆ Due to the risk of severe injury or death, in case of a broken oil line, broken controls, or missing key, do not attempt to operate the lift. Instead, contact BendPak Customer Service at (805) 933-9970 in order to fix the broken or failed parts and request a qualified service technician visit to repair the lift.

LIFT WILL NOT RAISE

POSSIBLE CAUSE

1. Air in oil, (1,2,8,13)
2. Cylinder binding, (9)
3. Cylinder leaks internally, (9)
4. Motor run backward under pressure, (11)
5. Lowering valve leaks, (3,4,6,10,11)
6. Motor runs backwards, (7,14,11)
7. Pump damaged, (10,11)
8. Pump won't prime, (1,8,13,14,3,12,10,11)
9. Relief valve leaks, (10,11)
10. Voltage to motor incorrect, (7,14,11)

REMEDY

1. Check for proper oil level.
2. Bleed cylinders.
3. Flush- Release valve to get rid of.
possible contamination
4. Dirty oil.
5. Tighten all fasteners.
6. Check for free movement of release.
7. Check motor is wired correctly.

INSTRUCTION

- The oil level should be up to the bleed screw in the reservoir with the lift all the way down.
- See Installation Manual
- Hold release handle down and start unit allowing it to run for 15 seconds.
- Replace oil with clean, approved ATF fluids such as: Dexron III, Dexron VI, Mercon V, Mercon LV or comparable.
- Tighten fasteners to recommended torques.
- If handle does not move freely, replace bracket or handle assembly.
- Compare wiring of motor to electrical diagram on drawing.

- 8. Oil seal damaged or cocked Replace oil seal around pump shaft.
- 9. See Installation Manual Consult Lift Manufacturer.
- 10. Replace with new part Replace with new part.
- 11. Return unit for repair Return unit for repair.
- 12. Check pump-mounting bolts Bolts should be 15 to 18 ft. lbs.
- 13. Inlet screen clogged Clean inlet screen or replace.
- 14. Check wall outlet voltages and wiring Make sure unit and wall outlet are wired properly.

MOTOR WILL NOT RUN

POSSIBLE CAUSE

- 1. Fuse blown, (5,2,1,3,4)
- 2. Limit switch burned out, (1,2,3,4)
- 3. Microswitch burned out, (1,2,3,4)
- 4. Motor burned out, (1,2,3,4,6)
- 5. Voltage to motor incorrect, (2,1,8)

REMEDY

- 1. Check for correct voltage Compare supply voltage with voltage on motor name tag. Check that the wire is sized correctly. N.E.C. table 310-12 requires AWG 10 for 25 Amps.
- 2. Check motor is wired correctly Compare wiring of motor to electrical diagram on drawing.
- 3. Don't use extension cords According to N.E.C. : " The size of the conductors... should be such that the voltage drop would not exceed 3% to the farthest outlet for power..." Do not run motor at 115 VAC – damage to the motor will occur.
- 4. Replace with new part Replace with new part.
- 5. Reset circuit breaker/fuse Reset circuit breaker/fuse.
- 6. Return unit for repair Return unit for repair.
- 7. See Installation Manual See Installation Manual.
- 8. Check wall outlet voltage and wiring Make sure unit and wall outlet is wired properly. Motor must run at 208/230 VAC.

LIFT LOWERS SLOWLY OR NOT AT ALL

POSSIBLE CAUSE

1. Cylinders binding, (1)
2. Release valve clogged, (5,4,2,3)
3. Pressure fitting too long, (6)

REMEDY

INSTRUCTION

- | | |
|---|--|
| 1. See Installation Manual | Consult Lift Manufacturer. |
| 2. Replace with new part | Replace with new part. |
| 3. Return for repair | Return for repair. |
| 4. Check oil. | Use clean 10-WT hydraulic oil or any approved ATF fluid such as: Dexron III, Dexron VI, Mercon V, Mercon LV or comparable. If ATF is contaminated, replace with clean ATF and clean entire system. |
| 5. Clean release valve | Wash release valve in solvent and blow out with air. |
| 6. Replace fitting with short thread lead | Replace fitting with short thread lead. |

WILL NOT RAISE LOADED LIFT

POSSIBLE CAUSE

1. Air in oil, (1,2,3,4)
2. Cylinder binding, (5)
3. Cylinder leaks internally, (5)
4. Lift overloaded, (6,5)
5. Lowering valve leaks, (7,8,1,5,9)
6. Motor runs backwards, (10,12,9)
7. Pump damaged, (5,9)
8. Pump won't prime, (1,2,3,4,5,11,9)
9. Relief valve leaks, (8,5,9)
10. Voltage to motor incorrect, (10,12,5)

REMEDY

INSTRUCTION

- | | |
|---|--|
| 1. Check oil level | The oil level should be up to the bleed screw in the reservoir [with the lift all the way down.] |
| 2. Check/Tighten inlet tubes | Replace inlet hose assembly. |
| 3. Oil seal damaged or cocked | Replace oil seal and install. |
| 4. Bleed cylinders | See Installation Manual. |
| 5. See Installation Manual | Consult Lift Manufacturer. |
| 6. Check vehicle weight | Compare weight of vehicle to weight limit of the lift. |
| 7. Flush release valve | Hold release handle down and start unit allowing it to run for 15 seconds. |
| 8. Replace with new part | Replace with new part. |

- 9. Return unit for repair Return unit for repair.
- 10. Check motor is wired correctly Compare wiring of motor to electrical diagram on power unit drawing.
- 11. Inlet screen clogged Clean inlet screen or replace.
- 12. Check wall outlet voltage and wiring Make sure unit and wall outlet is wired properly.

LIFT WILL NOT STAY UP

POSSIBLE CAUSE

- 1. Air in oil, (1,2,3)
- 2. Check valve leaks, (6)
- 3. Cylinders leak internally, (7)
- 4. Lowering valve leaks, (4,5,1,7,6)
- 5. Leaking fittings, (8)

REMEDY

INSTRUCTION

- 1. Check oil level The oil level should be up to the bleed screw in the reservoir with the lift all the way down.
- 2. Oil seal damaged and cocked Replace oil seal around pump shaft.
- 3. Bleed cylinder Refer to Installation Manual.
- 4. Flush release valve Hold release handle down and start unit allowing it to run for 15 seconds.
- 5. Replace with new valve Replace with new valve.
- 6. Return unit for repair Return unit for repair.
- 7. See Installation Manual Consult Lift Manufacturer.
- 8. Check complete hydraulic system for leaks. Tighten all hydraulics fittings and inspects all hoses.

A

FRONT

PARKING LIFT OPERATION WARNINGS

Read the entire operation manual, and operation instructions shown on the reverse side of this placard before operating this parking lift. If any questions arise as to the safety or operation of this lift contact your property manager, building engineer, local parking lift dealer or call BestPak at 1 (800) 523-4670. Always use caution when operating this lift. Never allow children or persons under the influence of drugs or alcohol to use this lift. Serious injury, property damage, and/or death can occur if this lift is improperly used.

⚠ WARNING

ALWAYS double-check under clearance BEFORE driving vehicle under lift platform.

⚠ WARNING

Never place any object or any part of your body on the legs or any other part of the lift during operation. Serious injury or death can occur.

⚠ WARNING

- Read the entire operation manual before operating this parking lift.
- NEVER leave the lift unattended when it is partially raised or lowered.
- DO NOT raise the lift platform when the lift is empty. The lifts are designed to be lowered with the weight of a vehicle on the platform. Empty lifts will take much longer to lower.
- Always use caution when operating this lift. Never allow children or persons under the influence of drugs or alcohol to use this lift.
- Serious injury, property damage, and/or death can occur if this lift is improperly used.
- Keep hands and feet clear. Remove hands and feet from any moving parts. Keep feet clear of lift when lowering. Avoid pinch points.
- Only trained operators should operate this lift. All non-trained personnel should be kept away from work area. Never let non-trained personnel come in contact with, or operate lift.
- Guard against electric shock. This lift must be grounded while in use to protect the operator from electric shock.
- Risk of explosion. This lift has internal arcing or sparking parts which should not be exposed to flammable vapors.
- Maintain lift with care. Keep lift clean for better and safe performance. Follow manual for proper lubrication and maintenance instructions. Keep control handles and/or buttons dry, clean and free from grease and oil.
- Stay alert - watch what you are doing. Use common sense and always be aware.
- Check for damaged parts. Check for alignment of moving parts, breakage of parts or any condition that may affect safe operation of the lift. Do not use lift if any component is broken or damaged.
- Never remove safety related components from the lift. Do not use lift if safety related components are damaged or missing.

IMPORTANT NOTE

The custom lock-setting of the lift determines the height of the vehicles that can be safely parked underneath the lift. Make sure that you are using only vehicles that are of the proper height for the custom lock-setting. If the setting of your lift needs to be changed, contact your parking lift dealer.

BACK

PARKING LIFT OPERATION INSTRUCTIONS

Read the entire operation manual and warning instructions shown on the reverse side of this placard before operating this parking lift.

PRE-LIFTING STAGE

1. Drive top vehicle onto the elevating platform. Vehicles may be driven in nose first or backed in.
2. Drive until the top vehicle's forward tires rest against the forward wheel stop.
3. Turn off car engine, engage safety brake, and place the vehicle's gear selector in Park. If vehicle is manual transmission, place the transmission in first gear.
4. Walk to the rear of the platform and lift up on the red handle to engage the rear tire stops.
5. Check the front of the lift to make sure that the vehicle's forward tires are securely set against the wheel stop.
6. Walk around the lift to ensure no obstructions will interfere with the vehicle being lifted.
7. Position yourself in front of the lift within reach of the operator control console.

LIFTING STAGE

1. Once all precautions above are followed, check around and above the lift to ensure that no objects are in the platform's way, and that no persons (except the lift operator) are within 10 feet.
2. To raise the lift platform with top vehicle to desired height, turn the operator switch on the control console to the right position and hold.
3. During operation, observe the entire perimeter of the lift as well as overhead to ensure there are no obstructions that may damage vehicle and / or lift.
4. ALWAYS raise the platform until it reaches its top custom-set lock position.
5. If a low ceiling is overhead be careful when lifting. NEVER allow the top vehicle to come in contact with any overhead structure or object.
6. Once top position is reached, release the operator switch to its neutral position then turn and hold the operator switch to the left position to lower the platform with vehicle onto the lift's mechanical locks. Hold the operator switch in the left position until the platform is resting securely on the locks.
7. Walk around, never under the raised platform.

REMOVAL OF LOWER VEHICLE

1. Carefully drive out the lower vehicle after making sure it is clear before lowering the lift platform.

LOWERING THE LIFT

1. Walk around the lift to make sure nothing is below or near the lift platform's entire lower area to prepare for descent.
2. Be certain that no person (except the lift operator) is within 10 feet of the lift area.
3. Turn and hold the operator switch to the right position to elevate the lift approximately two inches or enough to allow release of the mechanical locks and release operator switch to its neutral position.
4. While pulling back and holding the lock release safety lever located below the control console, turn and hold the operator switch to the left position to lower the lift platform with top vehicle.
5. When lowering the lift always be watchful for objects, persons or animals that may wander under the lift platform during operation. Cease operation if area becomes obstructed.
6. KEEP HANDS AND FEET CLEAR OF ALL MOVING PARTS AND PINCH POINTS.
7. Release the lock release safety lever and operator switch upon full descent of platform.
8. Walk to the rear of the lift and lower the wheel stops / ramps.
9. Carefully drive out the lower vehicle after making sure it is clear before lowering the lift platform.



PLACEMENT OF LOWER VEHICLE

1. Once all precautions of the Pre-Lifting and Lifting Stage have been followed, drive the lower vehicle under the lift platform until the forward tires reach the front wheel bar, or, to the location where the car is properly positioned under the lift to allow clearance of the doors and mirrors.
2. Turn off the engine, set the parking brake and place in the gear selector in Park, or place manual transmission in gear.

148 000003

B



**KEEP HANDS AND FEET
CLEAR AT ALL TIMES FROM
MOVING MACHINERY**
GARDEZ LES MAINS ET LES PIEDS
À DISTANCE À TOUT MOMENT DES
MACHINES EN MOUVEMENT



C



D

⚠ DANGER

**THE MAXIMUM LIFTING CAPACITY
FOR THIS LIFT IS DESCRIBED BELOW**

Maximum Lifting Capacity
7,000 lbs. / 3,175 kg
Max. Lifting Cap. / Front of Lift Center
3,500 lbs. / 1,588 kg
Max. Lifting Cap. / Rear of Lift Center
3,500 lbs. / 1,588 kg

Exceeding the weight capacity of this lift can damage lift and/or property and may cause personal harm, injury or death to operators and/or bystanders. All vehicles MUST be positioned on lift with CENTER OF GRAVITY midway between adapters and/or centered on runways. Damage to lift due to overloading or misuse IS NOT covered under warranty.

**LA CAPACITÉ DE LEVAGE MAXIMUM
POUR CE LEVAGE EST DÉCRIT CI-DESSOUS**

Capacité de Levage Maximale
7,000 lbs. / 3,175 kg
Max. Capacité De Levage. / Avant du centre de relèvement
3,500 lbs. / 1,588 kg
Max. Capacité De Levage. / Arrière du centre de levage
3,500 lbs. / 1,588 kg

Le dépassement de la capacité de poids de cet élévateur peut endommager l'ascenseur et / ou les biens et peut causer des dommages corporels, des blessures voire la mort aux opérateurs et / ou aux passants. Tous les véhicules DOIVENT être placés sur l'élèveur avec le CENTRE DE GRAVITÉ à mi-chemin entre les adaptateurs et / ou au centre des pistons. Dommages à

E

BP BendPak. Santa Paula, CA USA www.bendpak.com	
MODEL NUMBER	
DESCRIPTION	
LIFT CAPACITY	DATE CODE
VOLTAGE	SERIAL NUMBER
<input type="checkbox"/> 110-120V, 50-60 Hz, 1 Ph	UPC
<input type="checkbox"/> 208-240V, 50-60 Hz, 1 Ph	
<input type="checkbox"/> 380-415V, 50-60 Hz, 3 Ph	
<input type="checkbox"/> 208-440V, 50-60 Hz, 3 Ph	
DANGER! Disconnect Power Before Servicing	ERC
MADE IN CHINA	WARRANTY VOID IF DATA PLATE IS REMOVED PN 1305261

G



F



USE ON GALVANIZED
OPTION ONLY

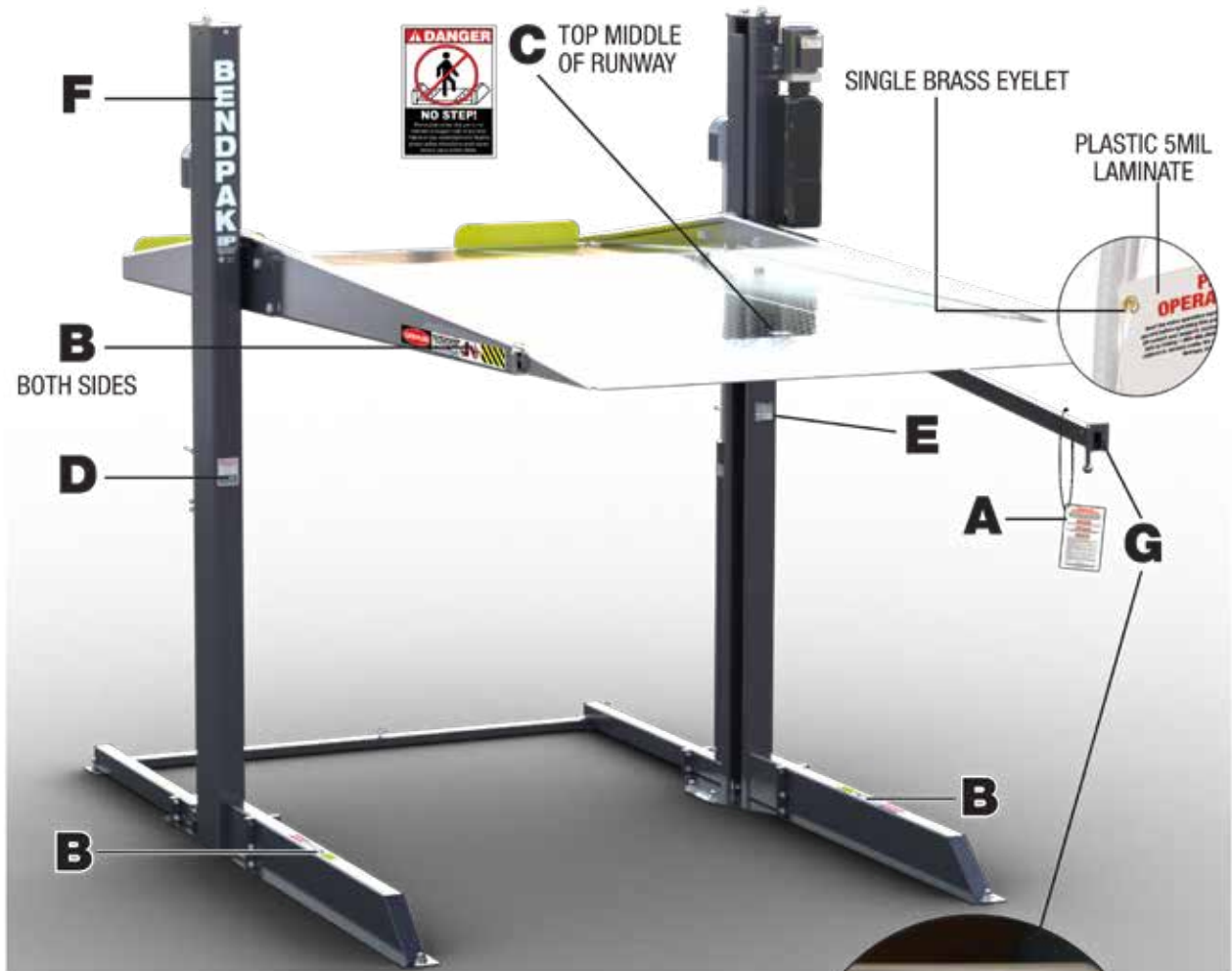

**OPEN/CLOSE PLATE SHOULD BE REMOVED.
Replace with LABEL "G"**

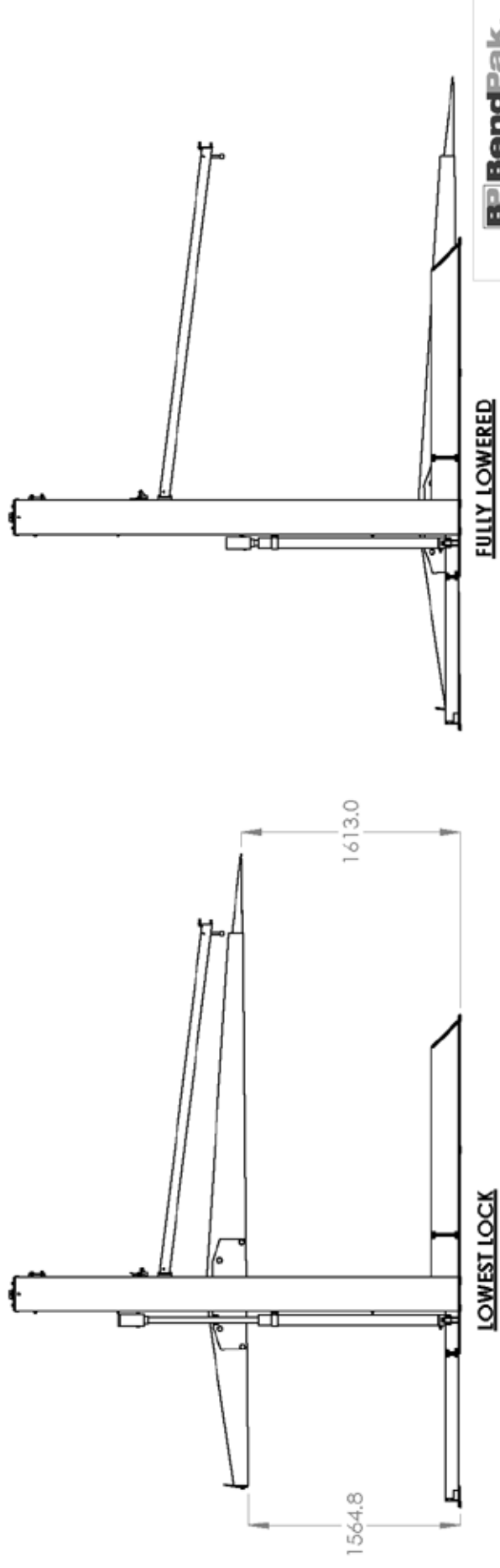
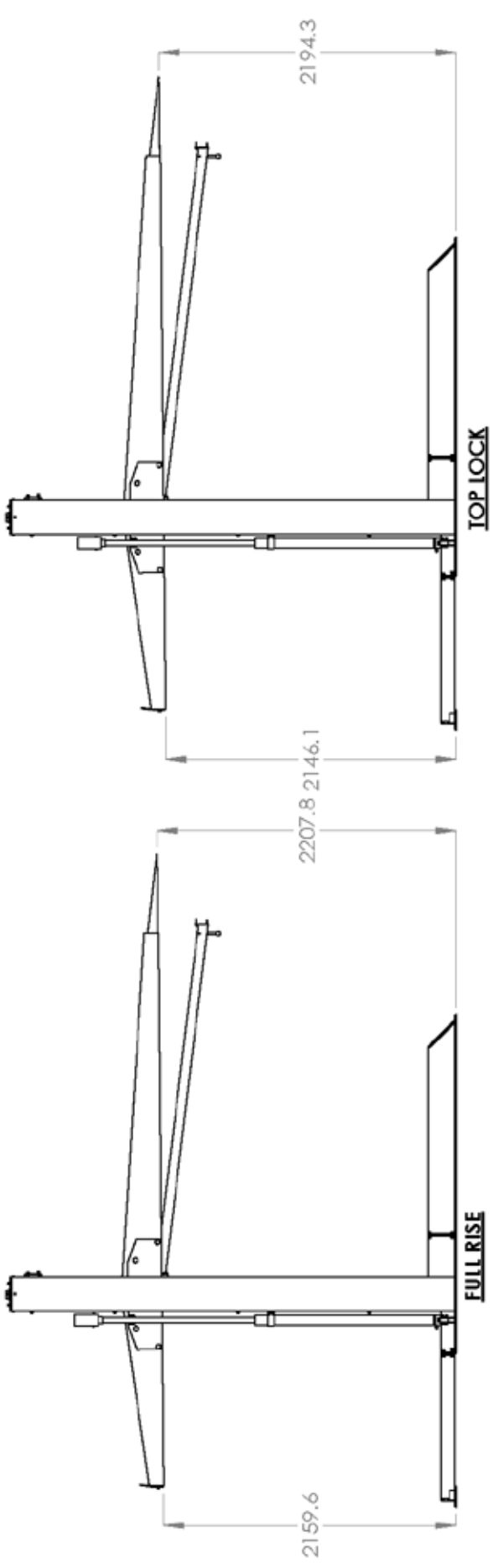

BP BendPak. 1645 LEMONWOOD DR. SANTA PAULA, CA 93060	
TITLE:	PL-7000DLX PRODUCTION LIFT VER B
SEE DWG. NO.	REV
A	A
SCALE: 1:45	
SHEET 3 OF 3	

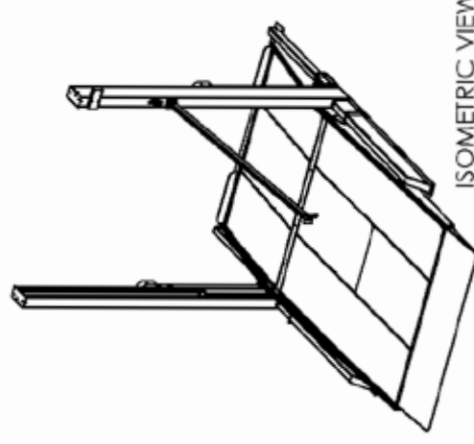
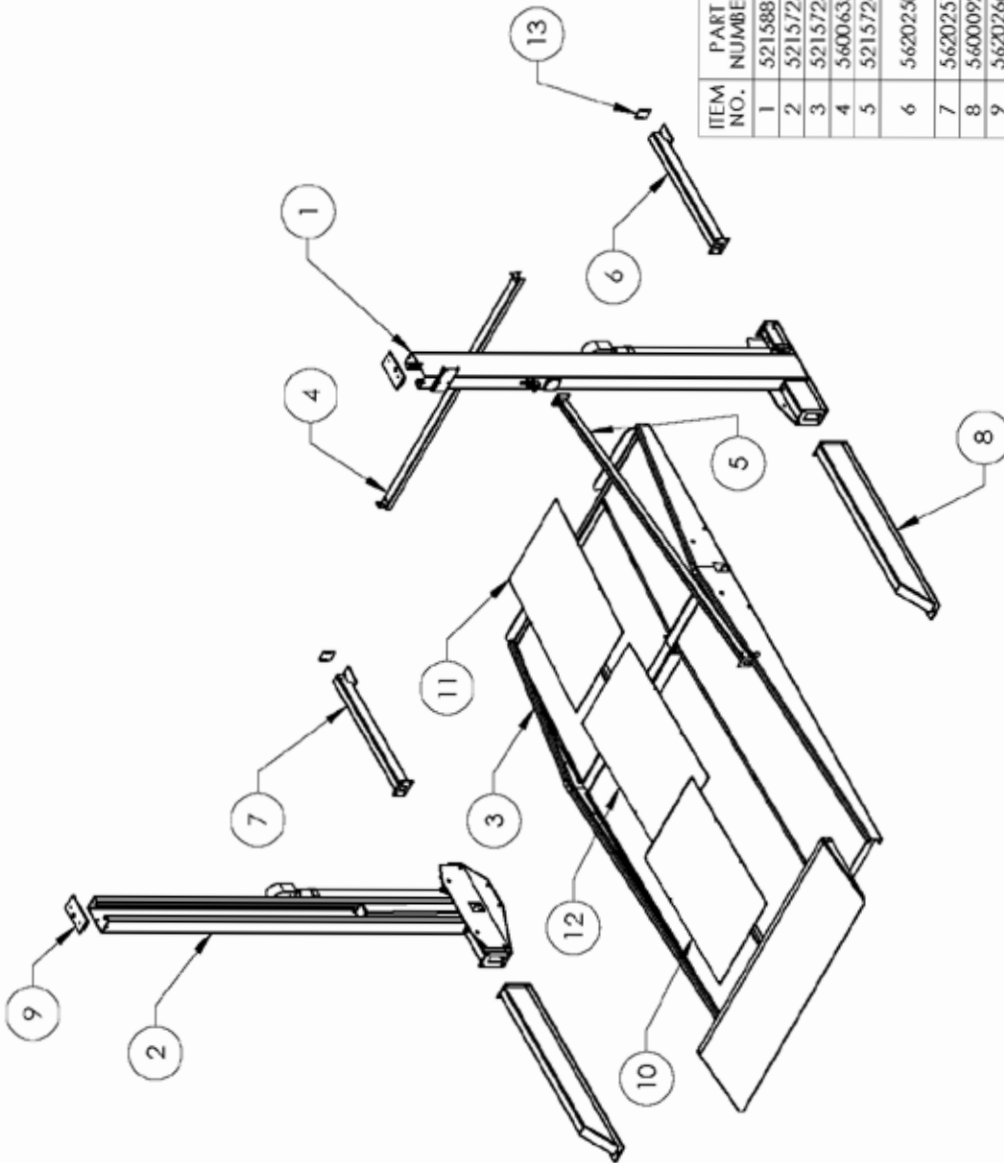

ISOMETRIC VIEW
FOR REFERENCE ONLY
DO NOT SCALE

ITEM NO.	PART NUMBER	DESCRIPTION	QTY	REV
1	5215881	PL-7000DIX CONTROL POST ASSEMBLY	1	A
2	5215727	PL-7000DIX OFF SIDE POST ASSEMBLY	1	G
3	5215725	PL-7000DIX DRIVE UP RAMP ASSEMBLY	1	C
4	5600635	PL-7000DIX FLOOR CROSS TUBE WELDMENT	1	C
5	5215724	PL-7000DIX CONTROL ARM ASSEMBLY	1	A
6	5620250	PL-7000DIX POWER SIDE POST BASE EXTENSION WELDMENT	1	D
7	5620251	PL-7000DIX OFF SIDE POST BASE EXTENSION WELDMENT	1	D
8	5600092	PL-7000DIX TAPERED FOOT WELDMENT	2	D
9	5620266	PL-7000DIX TOP PLATE WELDMENT	2	C
10	5601169	PL-7000DIX REAR DECK WELDMENT	1	A
11	5730679	PL-7000DIX FRONT DECK PLATE	1	A
12	5730678	PL-7000DIX DECK PLATE	1	A
13	5701083	PL-7000DIX TUBE EXTENSION COVER	2	D
14	5600701	PL-7000DIX EXTENDED DRIVE UP RAMP WELDMENT	1	C

DO NOT SCALE DRAWING

DRAWN	NAME	DATE
C.A.		11/08/2019
CHECKED		12/23/2019

THIRD ANGLE PROJECTION

BendPak.
1645 LEMMONWOOD DR.
SANTA PAULA, CA 93060

TITLE: PL-7000DIX LIFT SUPERSTRUCTURE

SEE DWG. NO. **A** 5245077 REV **A**

PROPRIETARY AND CONFIDENTIAL
THE INFORMATION CONTAINED IN THESE DRAWINGS IS THE SOLE PROPERTY OF BENDPAK INC. ANY REPRODUCTION OR TRANSMISSION IN ANY FORM OR BY ANY MEANS WITHOUT THE WRITTEN PERMISSION OF BENDPAK INC. IS PROHIBITED.

DIMENSIONS ARE IN INCH

SCALE: 1:45 SHEET 1 OF 1

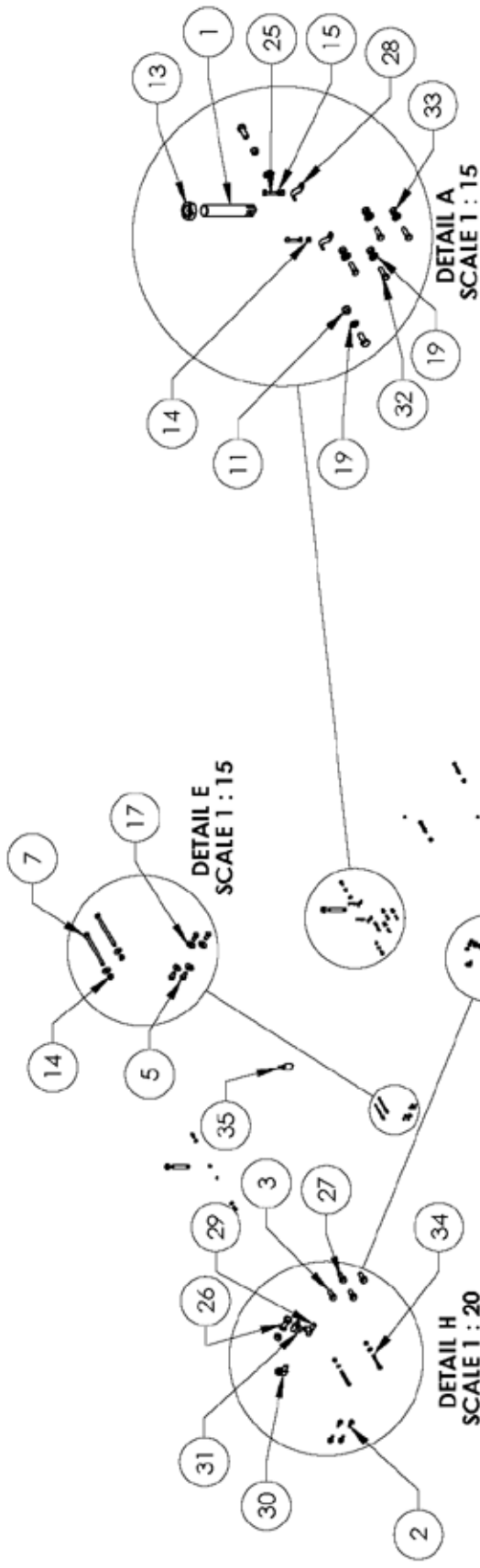

ITEM NO	PART NUMBER	DESCRIPTION	QTY	REV
1	5746024	PL-7000DLX AD-LISTABLE CHAIN CONNECTOR	2	C
2	5507459	HHB M6 X 1.5 X 20	8	-
3	5507458	HHB M10 X 1.5 X 25	8	-
4	5500133	HHB M6 X 1.0 X 5	4	-
5	5500131	HHB M6 X 1 X 12	8	-
6	5530009	HHB M12 X 1.75 X 90 C18.8	8	-
7	5530037	HHB M6 X 1 X 90	4	-
8	5530154	HHB M20 X 2.5 X 45	4	-
9	5530116	HHB M12 X 1.75 X 40	26	-
10	5530112	NUT M12 X 1.75 NL	16	-
11	5535013	NUT M10 X 1.5 NL	4	-
12	5535017	NUT M20 X 2.5 NL	4	-
13	5535018	NUT M24 X 2.0 NL	2	-
14	5535019	NUT M6 X 1.0 NL	2	-
15	5535020	M6 FLAT WASHER	26	-
16	5535021	WASHER M12 SPRING LOCK	26	-
17	5535022	WASHER 6mm X 18mm	12	-
18	5535023	WASHER M20 FLAT	8	-
19	5535024	WASHER M10 X 20 FLAT	8	-
20	5530100	FIG NPT -04 JIC X-06 NPT	20	-
21	5535035	C WASHER SHIM FOR LIFTS	20	-
22	5530563	HHB M12 X 1.75 X 30 C10.9	8	-
23	5535026	WASHER M12 X 2.1 X C10.9	8	-
24	5535024	NUT M12 X 1.75 NL C10.9	8	-
25	5530118	HHB M6 X 1 X 25mm	26	-
26	5530119	HHB M12 X 1.75 X 30mm	26	-
27	5530115	WASHER M10 X 20 18.5	4	-
28	5530026	1/2" PIPE STRAP 200.6mm	2	-
29	5530181	FIG EL-04 JIC X-04 JIC X-04 NPT	1	-
30	5530103	FIG LUB-04 JIC-06 ORB	1	-
31	5530133	FIG ELB-04 NPT X-04 JIC	1	-
32	5530010	HHB M8 X 1.25 X 25	4	-
33	5535000	NUT M8 X 1.25 NL	4	-
34	5530159	SHCS M6 X 1.0 X 50	2	-
35	5580012	LIQUID PTFE THREAD SEALANT 4.0Z	2	-

DO NOT SCALE DRAWING

NAME DATE
TS 04/07/2017

DRAWN OR
CHECKED OR 03/25/2020

THIRD ANGLE PROJECTION

SMILEY FACE

DIMENSIONS ARE IN MM

PROPRIETARY AND CONFIDENTIAL
ALL INFORMATION CONTAINED HEREIN IS THE PROPERTY OF BENDPAK INC. REPRODUCTION IN PART OR AS A WHOLE WITHOUT THE WRITTEN PERMISSION OF BENDPAK INC. IS FORBIDDEN.

BendPak
1645 LEBANWOOD DR.
SANTA PAULA, CA 92060

TITLE: PL-7000DLX PARTS BAG

SEE DWG. NO. A 5174806

SCALE: 1:40

REV C

SHEET 1 OF 1

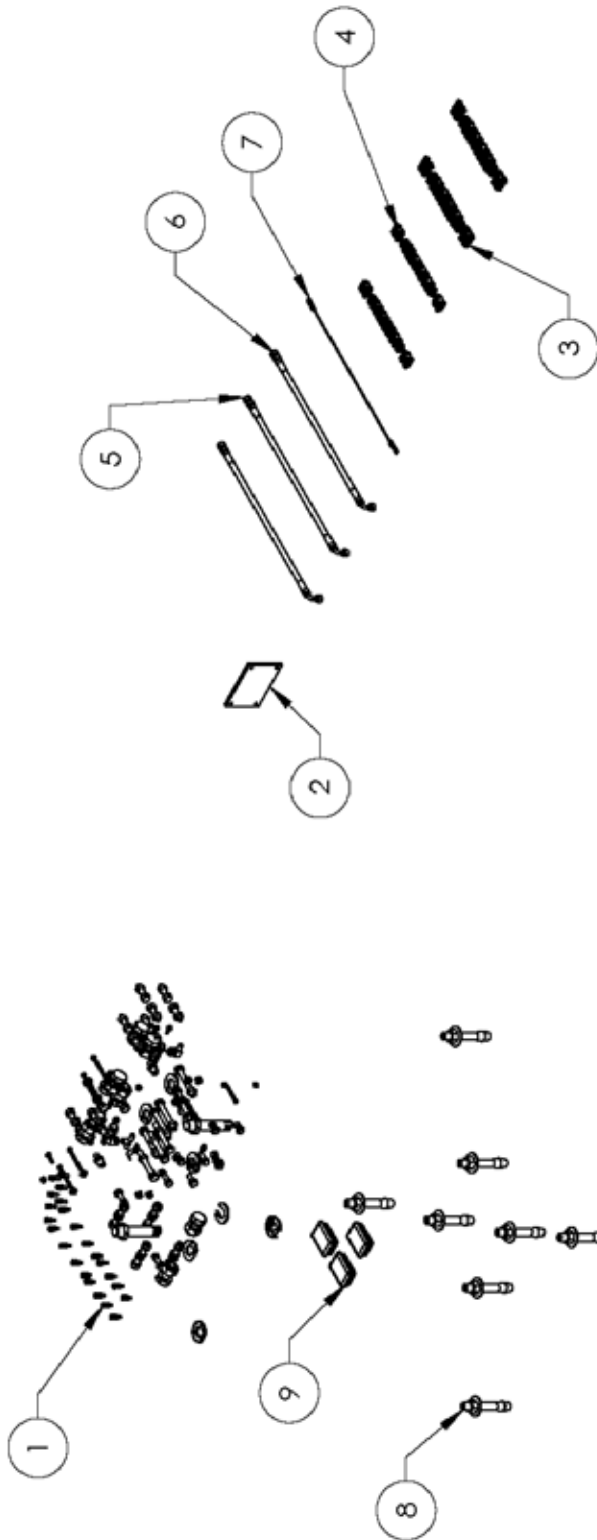

ITEM NO	PART NUMBER	DESCRIPTION	QTY	REV
1	5174806	PARTS BAG PL-7000DLX	1	B
2	5715003	POWER UNIT VIBRATION DAMPENER	1	B
3	5510101	PL-7000XR LIFT HEAD CHAIN	2	B
4	5510115	PL-7000XR EQUALIZER CHAIN	2	A
5	5570183	PL-7000XR HOSE ASSEMBLY Ø6.4 x 631.5mm SB	1	B
6	5570182	PL-7000XR HOSE ASSEMBLY Ø6.4 x 2480mm SB	2	B
7	5595384	PL-7000XR SAFETY CONTROL CABLE ASSEMBLY Ø2.4 x 2650mm	1	B
8	5530456	AB 3/4" x 4 - 3/4"	8	--
9	5715360	POLYETHYLENE TUBE COVER 2.00 x 3.00in	3	--

DO NOT SCALE DRAWING

BP **BendPak.**
 1645 LEMONWOOD DR.
 SANTA PAULA, CA 93060

DATE: 04/07/2017
 TS
 04/05/2019
 CA

TITLE: PL-7000DLX PARTS BOX

THIRD ANGLE PROJECTION

SMILEY FACE

PROPRIETARY AND CONFIDENTIAL
 THIS DRAWING IS THE SOLE PROPERTY OF BENDPAK INC. ANY
 REPRODUCTION IN PART OR AS A WHOLE WITHOUT
 THE WRITTEN PERMISSION OF BENDPAK INC. IS
 PROHIBITED.

SCALE: 1:20

DWG. NO. 5250372

REV C

SHEET 1 OF 1



1645 Lemonwood Dr. ● Santa Paula, CA. 93060, USA
Toll Free: 1(800) 253-2363

FOR TECHNICAL SUPPORT
1-(800) 253-2363 Ext. 196
TO ORDER PARTS
1-(800) 253-2363 Ext. 191