

Low-Rise Pit Lift

Installation and Operation Manual

Manual P/N 5900022 — Manual Revision C — June 2021

Models:

- P-9000LT
- P-9000LTF



Model P-9000LT shown.

Designed and engineered by BendPak Inc. in Southern California, USA. Made in China.

 **DANGER**

Read the *entire contents* of this manual *before* using this product. Failure to follow the instructions and safety precautions in this manual can result in serious injury or death. Make sure all other installers and operators also read this manual. Keep the manual near the product for future reference. *By proceeding with setup and operation, you agree that you fully understand the contents and assume full responsibility for product use.*

Manual. P-9000LT/F Low-Rise Pit Lift, *Installation and Operation Manual*, Manual Part Number 5900022, Manual Revision C, Released June 2021.

Copyright. Copyright © 2021 by BendPak Inc. All rights reserved. You may make copies of this document if you agree that: you will give full attribution to BendPak Inc., you will not make changes to the content, you do not gain any rights to this content, and you will not use the copies for commercial purposes.

Trademarks. BendPak and the BendPak logo are registered trademarks of BendPak Inc. All other company, product, and service names are used for identification only. All trademarks and registered trademarks mentioned in this manual are the property of their respective owners.

Manual Information. Every effort has been made to ensure complete and accurate instructions are included in this manual. However, product updates, revisions, and/or changes may have occurred since this manual was published. BendPak reserves the right to change any information in this manual without incurring any obligation for equipment previously or subsequently sold. BendPak is not responsible for typographical errors in this manual. You can always find the latest version of the **manual for your product on the BendPak website**.

Warranty. The BendPak warranty is more than a commitment to you: it is also a commitment to the value of your new product. Contact your nearest BendPak dealer or visit www.bendpak.com/support/warranty for full warranty details. Go to bendpak.com/support/register-your-product/ to fill out the online form to register your product (be sure to click **Submit**).

Safety. Your product was designed and manufactured with safety in mind. However, your safety also depends on proper training and thoughtful operation. Do not install, operate, maintain, or repair the unit without reading and understanding this manual and the labels on the unit; **do not use your Lift unless you can do so safely!**

Owner Responsibility. In order to ensure operator safety and maintain your product properly, it is the responsibility of the product owner to **read and follow** these instructions:

- Follow all installation, operation, and maintenance instructions.
- Make sure product installation and use conforms to all applicable local, state, and federal codes, rules, and regulations, such as state and federal OSHA regulations and electrical codes.
- Read and follow all safety instructions. Keep them readily available for operators.
- Make sure all operators are properly trained, know how to safely operate the unit, and are properly supervised.
- Do not operate the product until you are certain all parts are in place and operating correctly.
- Carefully inspect the product on a regular basis and perform all maintenance as specified.
- Service and maintain the unit only with approved replacement parts.
- Keep all instructions permanently with the product and make sure all labels are clean and visible.
- **Only use the Lift if it can be used safely!**

Unit Information. Enter the Model Number, Serial Number, and the Date of Manufacture from the label on your unit. This information is required for part or warranty issues.

Model: _____

Serial: _____

Date of Manufacture: _____

BP BendPak		Santa Paula, CA USA www.bendpak.com	
MODEL NUMBER			
DESCRIPTION			
LIFT CAPACITY		DATE OF MFG.	
VOLTAGE		SERIAL NUMBER	
<input type="checkbox"/> 110-240V, 50-60 Hz, 1 Ph			
<input type="checkbox"/> 208-240V, 50-60 Hz, 1 Ph			
<input type="checkbox"/> 380-415V, 50-60 Hz, 3 Ph			
<input type="checkbox"/> 208-440V, 50-60 Hz, 3 Ph			
		UPC	
		DANGER! Disconnect Power Before Servicing	
		WARRANTY VOID IF DATA PLATE IS REMOVED PN 5905951	
			

Table of Contents

Introduction	3	Operation	40
Shipping Information	4	Lift Arm Kit	45
Safety Considerations	4	Maintenance	47
Components	5	Troubleshooting	48
FAQs	7	Wiring Diagrams	49
Specifications	8	Labels	51
Installation Checklist	10	Parts Diagrams	55
Installation	11	Maintenance Logs	62

Introduction

This manual describes the P-9000LT and P-9000LTF, which are low-rise, frame-engaging, pit lifts that are designed and engineered for fast-paced auto shop environments, oil-change facilities, and home garages. They can be installed at ground level or recessed (the **F** in P-9000LTF stands for “flush mount”), generally over a service pit. Flush mount models do not use ramps, but they do require a recessed surface.

Both models raise Vehicles up to 9,000 lbs (4,082 kg). Both models are ALI certified (autolift.org) when used with a 220 VAC Power Unit.

More information about the full line of BendPak products is available at bendpak.com.

This manual is mandatory reading for all P-9000LT/F users, including anyone who installs, operates, maintains, or repairs them. You can always find the latest version of the **manual for your product on the BendPak website**.

⚠ DANGER Be very careful when installing, operating, maintaining, or repairing this equipment; failure to do so could result in property damage, product damage, injury, or (in very rare cases) death. Make sure only authorized personnel operate this equipment. All repairs must be performed by an authorized technician. Do not make modifications to the unit; this voids the warranty and increases the chances of injury or property damage. Make sure to read and follow the instructions on the labels on the unit.

Keep this manual on or near the equipment so that anyone who uses or services it can read it.

If you are having issues, refer to the **Troubleshooting** section of this manual for assistance.

Technical support and service is available from your dealer, on the Web at bendpak.com/support, by email at support@bendpak.com, or by phone at **(800) 253-2363**, extension 196.

You may also contact BendPak for parts replacement information (please have the model and serial number of your unit available) at **(800) 253-2363**, extension 191.

Shipping Information

Your equipment was carefully checked before shipping. Nevertheless, you should thoroughly inspect the shipment **before** you sign to acknowledge that you received it.

When you sign the bill of lading, it tells the carrier that the items on the invoice were received in good condition. **Do not sign the bill of lading until after you have inspected the shipment.** If any of the items listed on the bill of lading are missing or damaged, do not accept the shipment until the carrier makes a notation on the bill of lading that lists the missing and/or damaged goods.

If you discover missing or damaged goods **after** you receive the shipment and have signed the bill of lading, notify the carrier at once and request the carrier to make an inspection. If the carrier will not make an inspection, prepare a signed statement to the effect that you have notified the carrier (on a specific date) and that the carrier has failed to comply with your request.

It is difficult to collect for loss or damage after you have given the carrier a signed bill of lading. If this happens to you, file a claim with the carrier promptly. Support your claim with copies of the bill of lading, freight bill, invoice, and photographs. Our willingness to assist in helping you process your claim does not make us responsible for collection of claims or replacement of lost or damaged materials.

Safety Considerations

Read this manual carefully before using your new product. Do not install or operate the product until you are familiar with all operating instructions and warnings. Do not allow anyone else to operate the product until they are also familiar with all operating instructions and warnings.

General Safety Information

- The product is a low-rise pit Lift. Use it only for its intended purpose. Do not make any modifications to the product; if you do, you void your warranty.
- The product should only be operated by trained, authorized, supervised personnel.
- You **must** wear OSHA-approved (publication 3151) personal protective equipment at all times when installing, using, maintaining, or repairing the Lift: leather gloves, steel-toed work boots, eye protection, back belts, and hearing protection.
- Keep loads centered and balanced on the Platforms.
- When the Lift is in use, keep all body parts away from it. Only the Operator should be within 30 feet when the Lift is in use.
- Make sure all operators read and understand the *Installation and Operation Manual*. Keep the manual near the device at all times.
- Make a visual inspection of the product **every** day. Check for damaged or missing parts. Do not use the product if you find any issues. Instead, take it out of service, then contact your dealer, email support@bendpak.com, visit bendpak.com/support, or call **(800) 253-2363**.
- Make a **thorough** inspection of the product at least once a year. Replace any damaged or severely worn parts, decals, or warning labels.
- BendPak recommends referring to the ANSI/ALI ALIS Standard *Safety Requirements for Installation and Service* for more information about safely installing, using, and servicing your Lift.

Symbols

Following are the symbols used in this manual:



DANGER

Calls attention to an immediate hazard that **will** result in injury or death.



WARNING

Calls attention to a hazard or unsafe practice that **could** result in injury or death.



CAUTION

Calls attention to a hazard or unsafe practice that could result in personal injury, product damage, or property damage.

NOTICE

Calls attention to a situation that, if not avoided, could result in product or property damage.



Tip

Calls attention to information that can help you use the product better.

Liability Information

BendPak Inc. assumes **no** liability for damages resulting from:

- Use of the product for purposes other than those described in this manual.
- Modifications to the equipment without prior, written permission from BendPak Inc.
- Injury or death caused by modifying, disabling, overriding, or removing safety features.
- Damage to the equipment from external influences.
- Incorrect operation of the equipment.

Components

P-9000LT/F components include:

- **Console.** Hosts the controls for the Lift (on top) and the Power Unit (inside).
- **Power Unit.** Provides Hydraulic Fluid to the Hydraulic Cylinders, which they use to raise the Platforms. Housed inside the Console. Connects to an external power source.
- **Long Ramps.** Used to drive onto or off of the Platforms. Not included with the P-9000LTF. Install the Long Ramps on the side **opposite** the Hinged Ramps.
- **Short Ramps.** Used to drive onto or off of the Platforms. Not included with the P-9000LTF. Install the Short Ramps **next to** the Hinged Ramps.
- **Hinged Ramps.** Next to the Short Ramp while the P-9000LT/F is on the ground; hinges up when the Platforms are raised.
- **Platforms.** Flat steel plates that raise and lower. Platforms have openings for the optional Lift Arms. The Lift Blocks on the Platforms make contact with the undercarriage of the Vehicle in order to raise and lower the Vehicle.
- **Bases.** The bottoms of the Lift. They hold the Hydraulic Cylinders, Air Cylinders, Safety Locks, the holes for the Anchor Bolts, and more.
- **Frames.** The combination of the Platforms, the Bases, and the scissor components. Each P-9000LT/F is made up of two Frames, four Ramps (not the P-9000LTF), and one Console.
- **Hydraulic Cylinders.** Push the Platforms up to raise a Vehicle, move the Platforms down to lower a Vehicle.

- **Safety Locks.** Hold the Platforms while they are raised. Each Platform has four Safety Locks.
- **Air Cylinders.** Move the Platforms off the Safety Locks when you want to lower the Lift.
- **Lift Blocks.** Rubber blocks that make contact with the manufacturer's recommended Lifting Points on the underside of the Vehicle being raised. Always use the Lift Blocks to raise a Vehicle.
- **Lift Arms.** An optional accessory that provides additional raising capability for trucks and SUVs.

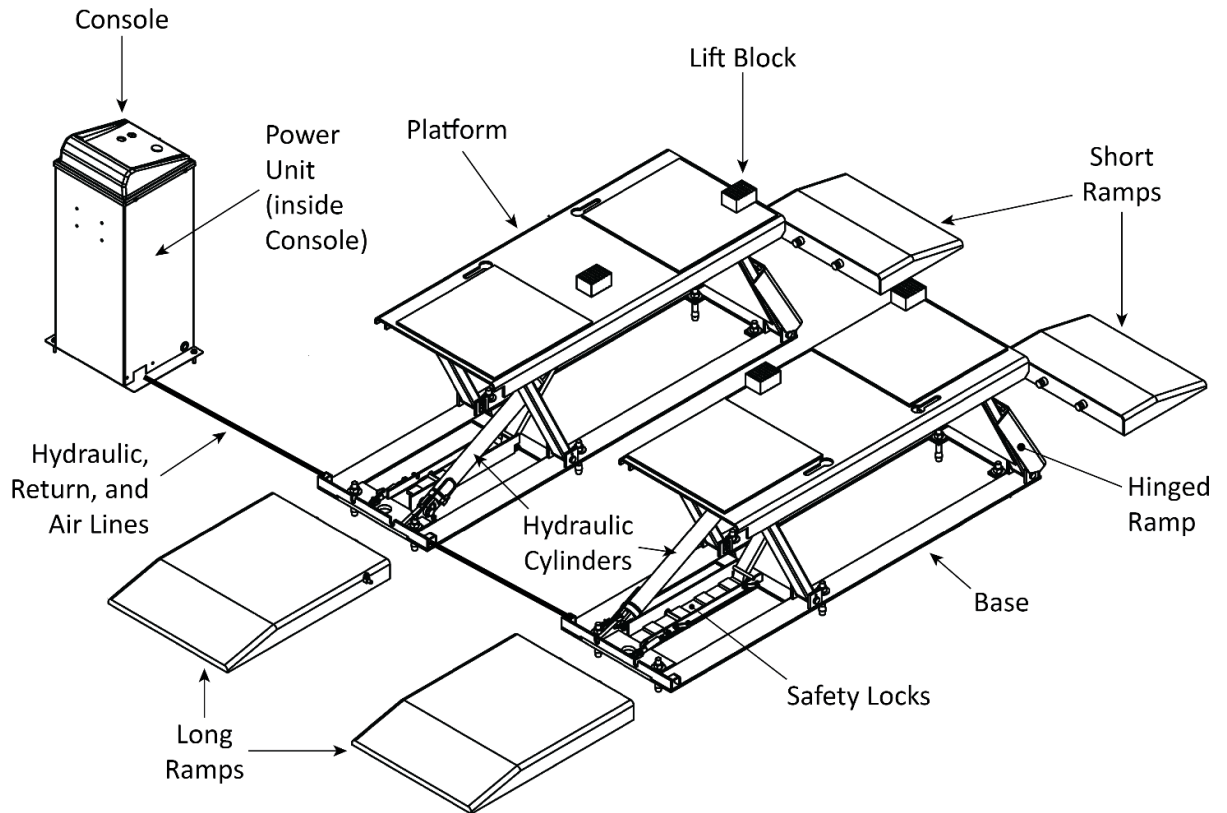

*Covers for Hydraulic, Return, and Air Lines included with Lift. Ramps shown in standard configuration: Short Ramps next to Hinged Ramps, Long Ramps on other side of Base. P-9000LT**F** does not have Long or Short Ramps. Optional Lift Arms not shown.*

Frequently Asked Questions

Question: How much weight can the P-9000LT/F raise?

Answer: The P-9000LT/F can raise Vehicles up to 9,000 pounds (4,082 kg).

Q: The P-9000LT/F is “flush mount”, what does that mean?

A: It means the Bases of the P-9000LT/F are installed below the surface of the Concrete so that no Ramps are needed. Instead, the tops of the Platforms are flush with the Concrete when the Lift is fully lowered, so Vehicles just drive straight on to the Platforms. Note that sufficient Concrete depth is required **under** the Concrete Cutout.

Q: The P-9000LT/F is called a “pit lift”, what does that mean?

A: It means that in addition to working great to raise Vehicles in any environment, the P-9000LT/F is optimized to hold Vehicles over a pit, which you would typically find at an oil-change facility or automotive shop. Adding a pit lift to an oil change facility lets you easily add wheel rotations and brake service to the services you already offer.

Q: Can the P-9000LT/F be installed outside?

A: No. The P-9000LT/F is approved for **indoor** installation and use only. **Outdoor installation is prohibited.**

Q: Can I put the Console on either side of the P-9000LT/F?

A: Yes. The Hydraulic Hoses that come with the P-9000LT/F are long enough to support the Console being up to 30 in / 762 mm away on either side.

Q: What if I want to raise a Vehicle that is slightly over the weight capacity of the Lift?

A: This is not an intended use of the product. Do **not** raise a Vehicle that is heavier than the rated capacity of your Lift.

Q: How many locking positions does my Lift have?

A: Four. This gives you multiple heights to which you can raise the Lift, so it is easy to find the best height for what you are doing.

Q: What do the Safety Locks do?

A: Safety Locks use gravity and intelligent engineering to hold the Platforms up, once they are engaged. Even if the Lift loses power, the Platforms stay where they are if they were left engaged on Safety Locks. **Only leave your Lift either lowered or engaged on Safety Locks.**

Q: Which end of the P-9000LT/F is the “front”?

A: Neither. Vehicles can be driven on to and off of the P-9000LT/F in either direction. The standard configuration is for the Short Ramps to be installed next to the Hinged Ramps and the Long Ramps to be installed on the other end. This configuration creates a flat, extended Platform onto which you drive the Vehicle to be raised. The extended Platform keeps the Vehicle flat and well above the Platforms, making it easy to position the Lift Blocks under the Vehicle’s manufacturer-recommended Lifting Points.

Q: The P-9000LT/F is described as “frame-engaging”, what does that mean?

A: It means the Platforms (actually, the Lift Blocks on the Platforms) contact the frame of the Vehicle to raise it. Put another way, the Vehicle is **not** raised by its wheels (as is the case with 4-post Lifts).

Specifications

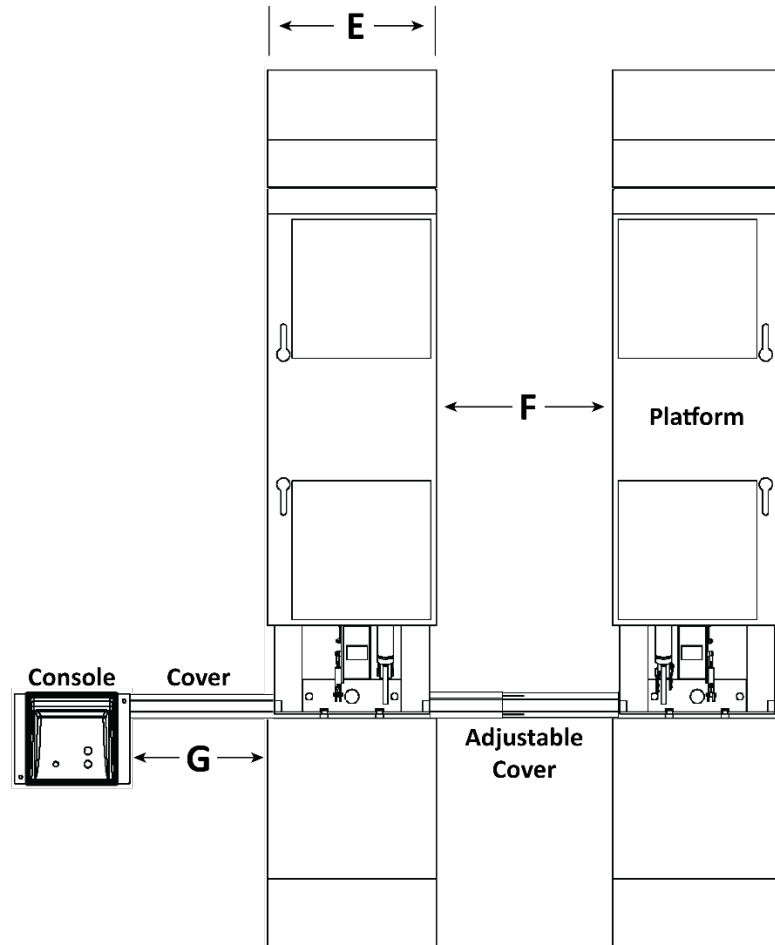
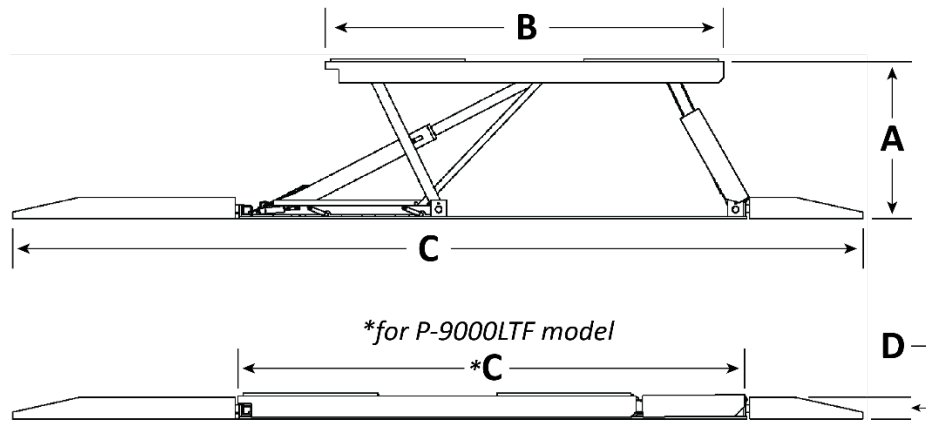

*P-9000LT shown. The P-9000LT**F** does not have Ramps or Covers.*

Model	P-9000LT	P-9000LTF
Style	Surface mount	Flush mount
Lifting capacity	9,000 lbs. / 4,082 kg	
A Lifting height	23.75" / 604 mm	
Lifting height + Block	27" / 685 mm	
B Overall Platform length	58.5" / 1,484 mm	
C Overall length	95" – 140.75" / 2,415 – 3,575 mm (with ramps)	74.5" / 1,890 mm (no ramps)
D Lowered height	4" / 99 mm	
E Platform width	24" / 610 mm	
F Width between Platforms	42" / 1,066 mm	23 to 42" / 584 to 1,066 mm
G Max distance to Console*	Up to 30" / 762 mm	
Maximum hydraulic pressure	2,800 PSI	
Lifting time	~35 seconds	
Motor**	208 – 240 VAC, 50/60 Hz, 1 Ph; 30 amp or greater breaker	
Sound	<70 dB	

* With *supplied* Hydraulic Hoses and Covers.

** 110 VAC units available on request. Lift loses ALI certification if used with a 110 VAC Power Unit.

Specifications subject to change without notice.

Installation Checklist

Following are the steps needed to install a P-9000LT/F Lift. Perform them in the order shown.

- 1. Review the installation Safety Rules.
- 2. Plan for Electrical Work.
- 3. Make sure you have the necessary Tools.
- 4. Select the Installation Location.
- 5. Make sure there is adequate clearance on all sides of the Lift.
- 6. Create the Concrete Cutouts (P-9000LTF only).
- 7. Create Chalk Line Guides (P-9000LT only).
- 8. Lift the Platforms off the Bases.
- 9. Learn about Embedment.
- 10. Anchor the Bases.
- 11. Set up the Console and attach the Power Unit.
- 12. Learn about Hydraulic Fluid Contamination.
- 13. Learn about Thread Sealants.
- 14. Connect the Hydraulic Hoses for a Standard 208-240 VAC Power Unit.
- 15. Connect the Hydraulic Hoses for a 110 VAC Power Unit.
- 16. Learn about Compression Fittings and Tubing.
- 17. Connect the Return Line.
- 18. Connect the Air Line.
- 19. Connect the Buttons.
- 20. Connect to Power. **Requires Electrician.**
- 21. Install a Power Disconnect Switch and Thermal Disconnect Switch. **Requires Electrician.**
- 22. Fill the Hydraulic Fluid Reservoir.
- 23. Test the Lift.
- 24. Add the Ramps (P-9000LT only).
- 25. Review the Final Checklist.

Installation

This section describes how to install your P-9000LT/F. Perform the steps in the order listed.

⚠ WARNING **Only use the factory-supplied parts that came with your Lift.** If you use parts from a different source, you void your warranty and compromise the safety of everyone who installs or uses the Lift. If you are missing parts, visit bendpak.com/support or call **(800) 253-2363**, extension 191.

The P-9000LT/F is supplied with installation instructions and concrete fasteners that meet the criteria set by the most recent version of the American National Standard “Automotive Lifts – Safety Requirements for Construction, Testing, and Validation” ANSI/ALI ALCTV.

Lift buyers are responsible for regional, structural, and/or seismic anchoring requirements specified by any other agencies or codes, such as the Uniform Building Code or International Building Code.

Safety Rules

When installing the Lift, your safety depends on proper training and thoughtful operation.

⚠ WARNING Do not install this equipment unless you have automotive Lift installation training. Always use proper tools, such as a Forklift or Crane, to move heavy components. Do not install this equipment without reading and understanding this manual and the safety labels on the unit.

BendPak recommends referring to the ANSI/ALI ALIS Standard *Safety Requirements for Installation and Service* for more information about safely installing, using, and servicing your Lift.

⚠ WARNING You **must** wear OSHA-approved (publication 3151) personal protective equipment **at all times** during installation: leather gloves, non-skid steel-toed work boots, eye protection, back belts, and hearing protection.

Preparing for Electrical Work

You will need to have a licensed, certified Electrician available at some point during the installation.

⚠ DANGER All wiring **must** be performed by a licensed, certified Electrician.

The Electrician needs to:

- **Connect the Power Unit to a power source.** This is generally done near the end of the installation. Installing the Power Unit and connecting the Power Unit to power are separate procedures; you do not need an Electrician to install the Power Unit. The Electrician needs to bring appropriate components to connect the Power Unit to the power source.

If you have a 110 VAC Power Unit, you do not need an Electrician to connect it.

- **Install a Power Disconnect Switch.** A Power Disconnect Switch gives you a way to shut down the Lift in the event of an electrical circuit fault or emergency situation. Refer to [Install a Power Disconnect Switch](#) for more information.
- **Install a Thermal Disconnect Switch.** A Thermal Disconnect Switch automatically shuts down the Lift in the event of an overload or an overheated motor. Refer to [Install a Thermal Disconnect Switch](#) for more information.

Tools

You may need some or all of the following tools:

- Rotary hammer drill or similar
- 3/4", 3/8", 1 1/4" masonry bits
- Hammer
- Open-end wrench set: 1/2", 15/16" – 1 1/8"
- Socket and ratchet set, 1 1/8"
- Medium crescent wrench
- Chalk line
- Medium slot screwdriver
- Tape measure
- Forklift or Shop Crane

Select a Location

Keep the following in mind when selecting a location for your P-9000LT/F:

- **Enough space.** Make sure there is adequate space on all sides, plus enough space above for the Vehicles you will be raising. See **Clearance Around the Lift** for more information.
- **Radial Shift.** When you raise the Lift, the geometry of the scissor arms moves the Platforms up at an angle, towards the Hinged Ramp end. The amount of radial shift for the P-9000LT/F is approximately 12 in / 305 mm. Note that radial shift is always this direction, towards the Hinged Ramp end of the Lift, no matter which way the Vehicle is facing.
- **Check for overhead obstructions.** The site must be free of overhead obstructions.
- **Concrete specifications.** Do not install the Lift on cracked or defective concrete. Make sure the Concrete is at least 4.25 inches thick, 3,000 psi, and cured for at least 28 days (if newly poured). Make sure the floor is defect-free, dry, and level. For flush-mount models, there must be 4.25 inches of concrete ***below the bottom of the Concrete Cutout.***

 **WARNING** Do not install the Lift on a surface with 3° of slope or more. A 3° slope or greater could lead to property damage, personal injury, or death; the slope makes the Lift less stable, which could lead to Vehicles falling off of it.

- **Power.** You will need either a 208 – 240 VAC or 110 VAC power source.
- **Operating temperature.** The Lift is designed to be used between temperatures of 41° to 104°F (5° to 40°C).
- **Outdoor installation.** The Lift ***cannot*** be installed outside. It is for ***indoor use only.***
- **Second floor installs.** Do not install the Lift on a second floor or elevated floor without first consulting the building architect and getting their permission.
- **Dress properly.** Do ***not*** wear loose clothing or jewelry; contain long hair; keep hair, clothing, and gloves away from moving parts.

 **WARNING** You ***must*** wear OSHA-approved (publication 3151) personal protective equipment at all times when installing, using, maintaining, or repairing the Lift: leather gloves, steel-toed work boots, eye protection, back belts, and hearing protection.

Clearance Around the Lift

For safety purposes, a certain amount of clear space around the Lift is **required**.

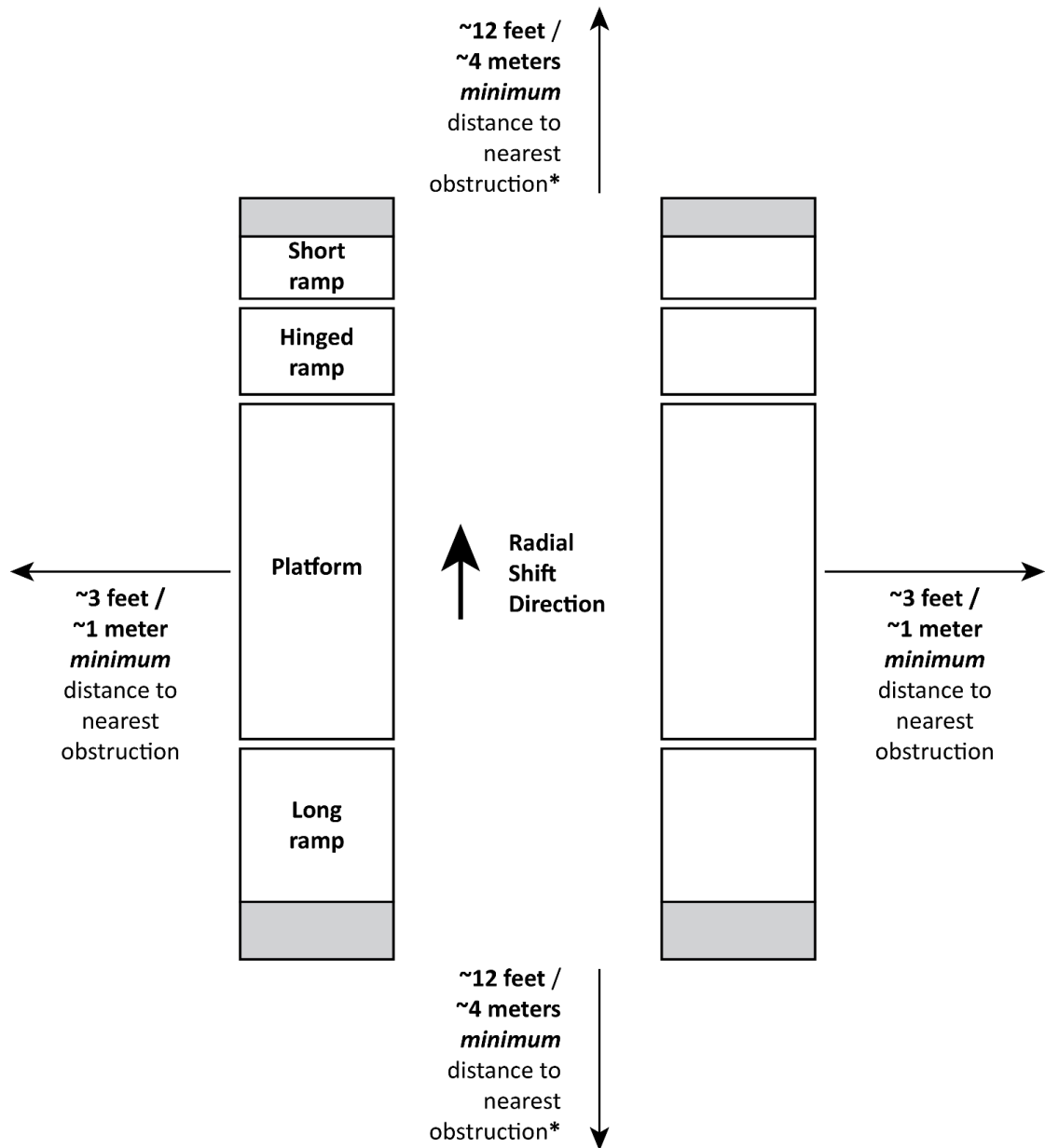

* If one end is **never** going to be used to drive on or off the Lift (there's a wall there, for example), then only ~3 feet / ~1 meter is needed to the nearest obstruction on that end.

P-9000LTF does not have Long or Short ramps. Not necessarily to scale.

P-9000LTF *Only*: Prepare the Concrete Cutouts

It is important to understand the following **before** creating the Concrete Cutouts for your Lift:

- A Flush-Mount Lift is one that sits in a recessed section of the floor, called a Concrete Cutout.
- Consult with your Concrete specialist **before** creating your Concrete Cutouts.
- Concrete Cutouts must be created in a **Concrete** floor; no other surface (asphalt, dirt, anything else) is acceptable.
- You can create one large Concrete Cutout (to hold both Frames) or two smaller Concrete Cutouts, one for each of the Lift's two Frames. This section assumes you are creating two.
- Concrete Cutouts must be a specific depth below the rest of the floor so when the Flush-Mount Lift is put down into the Concrete Cutout, the top of the Lift's Platforms are flush with the floor.
- To install a Flush-Mount Lift, you must create the Concrete Cutouts in advance, unless you already have Concrete Cutouts of the correct dimensions.
- You need to create your Concrete Cutouts at least a month in advance, as the Concrete **must cure for at least 28 days** before it is strong enough to support Anchor Bolts.
- There are three important factors to keep in mind when you are creating Concrete Cutouts: the Concrete depth **below the bottom** of the Concrete Cutouts must be deep enough for the Anchor Bolts, the size of the two rectangles must be big enough to fit the Bases of the Lift, and you need a method of connecting the hoses and lines to the Console.

NOTICE Installing a Flush-Mount Lift requires greater Concrete depth than a standard Lift. The Concrete Cutouts must be recessed the height of the Frame (Base plus Platform) and then have the required 4.25 inches of Concrete depth **below the bottom** of the Concrete Cutouts (for the Anchor Bolts).

- Regarding the Hoses and Lines: because the Lift's Bases are recessed, the Hydraulic Hoses and the Air and Return Lines start out recessed. Your plan for the Concrete Cutouts needs to account for how the hoses and lines will be routed to the Console.

Some people use PVC tubing to create a connection between the two Bases using the Hose Routing Rings on the inside of the Lift when they are creating their Concrete Cutouts. This allows the Hydraulic Hoses and the Air and Return Lines to be routed between the two Bases.

To connect to the Console, some people use PVC tubing to create a connection between the Console and the Hose Routing Ring on the Base closest to the Console. Other customers use the round Access Hole in the Base between the two Hose Routing Rings. The Access Hole is frequently used when the Lift is installed over a pit.

Consult with your Concrete specialist **before** creating your Concrete Cutouts.

- There are certain decisions you have to make **before** you create your Concrete Cutouts: where the Lift is going to go, where the Console will be (and thus how far away from the Lift it will be), and how far apart the two Frames will be.
- Regarding the distance between the two Frames: the P-9000LTF Frames can be from 23 to 42 inches (584 to 1,066 mm) apart. You need to decide how far apart you want your Frames **before** you create your Concrete Cutouts.

Important: BendPak strongly recommends consulting with your Concrete specialist **before** creating your Concrete Cutouts.

- The diagram on the following page provide information you and your Concrete specialist will need to create your Concrete Cutouts.

If you need to prepare a recessed surface for the P-9000LTF, use the following diagram as a guide.

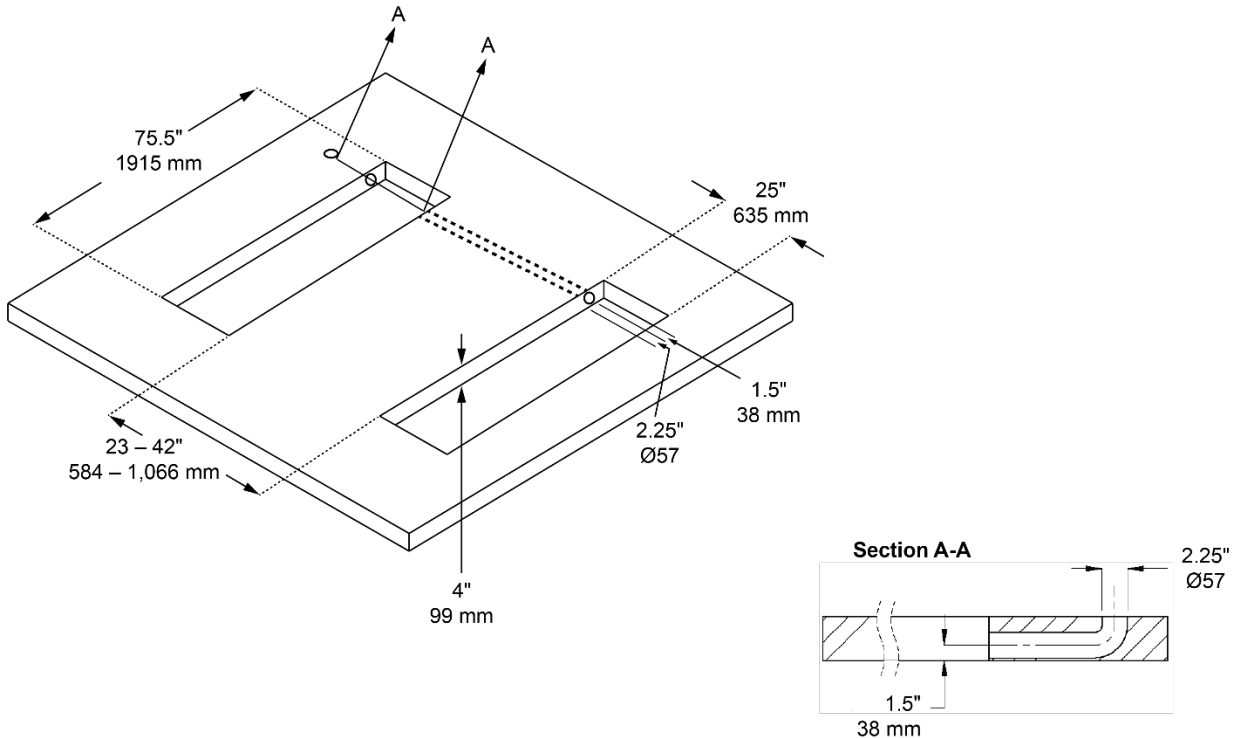

There must be 4.25 inches of concrete **below the bottom** of the Concrete Cutouts (for the Anchor Bolts).

The Concrete Cutout settings for a **P-9000LTF** are:

- **Length.** The Length of each Frame is 74.5 inches / 1,890 mm; add 1 inch / 25 mm to get **~75.5 inches / 1,915 mm.**
- **Width.** The Width of each Frame is 24 inches / 610 mm; add 1 inch / 25 mm to get **~25 inches / 635 mm.**
- **Depth.** The Lowered height of each Frame is **4 inches / 99 mm.** You do **not** add an extra inch to this value.
- **Distance Between.** The two Frames can be from **23 to 42 inches / 584 to 1,066 mm** apart. You do **not** add an extra inch to this value.
- **Distance to Console.** The supplied hydraulic hosing allows the Console to be up to **30 inches / 762 mm** from the nearest Base. You do **not** add an extra inch to this value.

NOTICE

If you create your Concrete Cutouts and then change your mind about the Distance Between or find out you made a mistake with one of the numbers, it is **very difficult to fix.** BendPak recommends you **double check your plan** several times *before* pouring your Concrete Cutouts.

Create Chalk Line Guides

Make sure to plan out, *in advance*, where the P-9000LT/F is going to go:

- **Clearance.** If you are installing the P-9000LT/F over a pit, you are restricted as to where you can put it. Be sure to make sure there is adequate clearance on all sides.
- **Console.** The Console must be positioned near the Lift; the Hydraulic Hoses that come with the P-9000LT/F are optimized for up to 30 inches between the Lift and the Console.
- **Operator.** The Operator at the Console **must** have a full, unobstructed view of the Lift.
- **Power.** The Console must also be positioned near an appropriate power source.
- **Hydraulic Cylinders on the inside.** The two Frames are **not** interchangeable. **The Hydraulic Cylinders must go on the inside** (on the pit side if installing over a pit).
- **Set up Chalk Line Guides.** Create Chalk Line Guides to make sure the Lift gets installed where you want it to get installed.

To create Chalk Line Guides:

1. Decide where you want the Lift.
2. Create an Alignment Chalk Line where you want one end of the P-9000LT/F.

Make the Alignment Chalk Line **longer** than the width of the P-9000LT/F and the Pit.

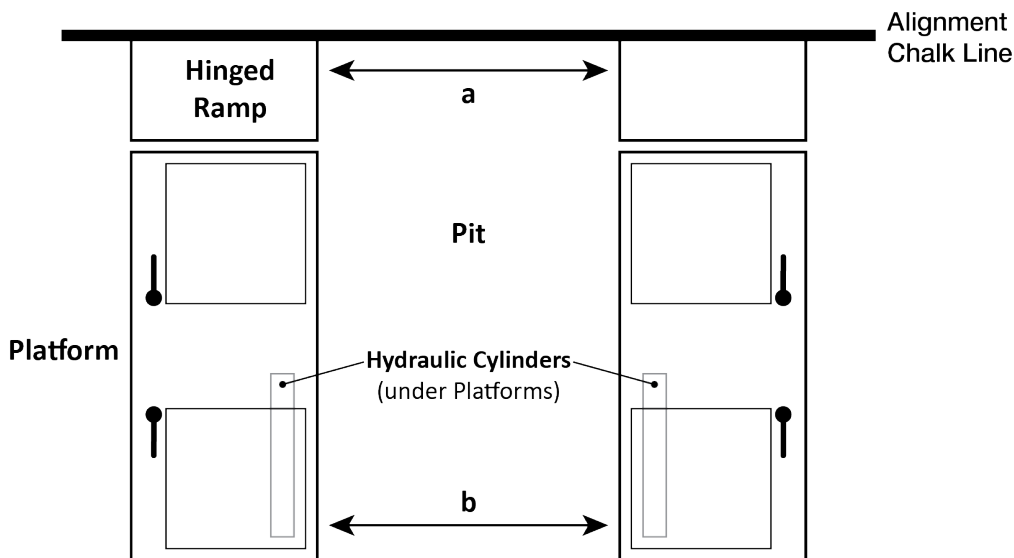

Top view. Not drawn to scale. Not all components shown.

3. Move the two Frames into position: the Hinged Ramp ends just inside the Alignment Chalk Line and the inside edges of the Frames aligned with the Pit.



Tip

This procedure assumes you are installing the Lift over a pit. If not, create two additional Chalk Line Guides: they need to be perpendicular to the Alignment Chalk Line, parallel to each other, and the distance apart you want the two Platforms (in the range of 23" to 42" / 584 mm to 1,066 mm).

4. Measure the distance between the two Platforms at points **a** and **b**; the two Platforms need to be the same distance apart at both ends.

Important: **a** and **b** **must** be the same distance apart and parallel to the Pit.

5. When the Platforms are in the correct location, they can be anchored into place.

Lift the Platforms Off the Bases

You must raise the Platforms off the Bases in order to complete some of following procedures, giving you the space to work.

When you raise the Lift, make sure to engage it on a Safety Lock.

⚠ WARNING BendPak strongly recommends using at least three people to lift the Platforms off the Bases: one person on each end to hold down the Base and one person to operate the Forklift or Shop Crane to raise the Platform. Use **care** when raising the Platforms off their Bases; they are heavy and can be difficult to hold.

To lift the Platforms off the Bases:

1. Position one person at each end of the Platform you want to raise off the Base.

These two people need to hold down the Base while the Platform is raised.

Only raise one Platform at a time.

2. Have the third person use a crowbar or other device to create separation between the Platform and the Base.

Make sure the Base is held down while you create the separation between Platform and Base.

3. Once the Platform and Base are separated by more than .5 inch (~13 mm), put industrial slings (straps) around each end, attach them to a lifting device such as a Forklift or Shop Crane, and then continue raising the Platform off the Base.

The following drawing shows the Platform being lifted off the Base.

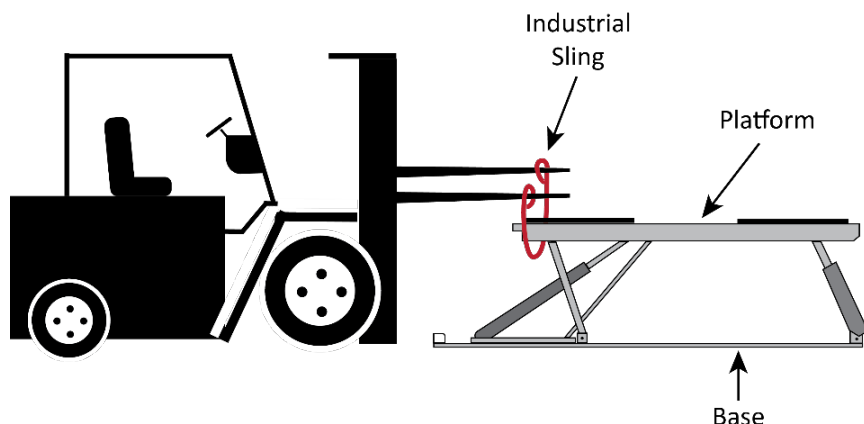

Make sure the Base is held down as the Lifting Device raises the Platform.

Side view. Not drawn to scale. Not all components shown.

4. When the Platform gets above the top Safety Lock, lower it back down onto the top Safety Lock.

⚠ WARNING Do not raise the Platform a random distance; leave it on the top Safety Lock.

5. Perform the same procedure on the second Platform and Base.

About Embedment

Anchor Bolts (also called Wedge Anchors) get their holding strength from how far down into the Hole the Anchor Bolt is installed (called embedment) and how forcefully the Expansion Sleeve presses into the Concrete (based on how much torque is applied).

To get *enough* embedment, you have to understand *Effective* Embedment, which means the location in the Hole where the Expansion Sleeve presses into the Concrete. This is where the Anchor Bolts create holding strength; the further down into the Hole, the greater the holding strength.

(The technical definition of Effective Embedment is the distance from the surface of the base material to the deepest point at which the load is transferred to the base material; the “base material” in our case being the Concrete into which the Anchor Bolts are being installed.)

Some people confuse Effective Embedment with Nominal Embedment, which is how far down into the Hole the bottom of the Anchor Bolt is.

As shown below, the two are not the same. Nominal Embedment is **not** where the load is transferred to the base material, *Effective Embedment* is.

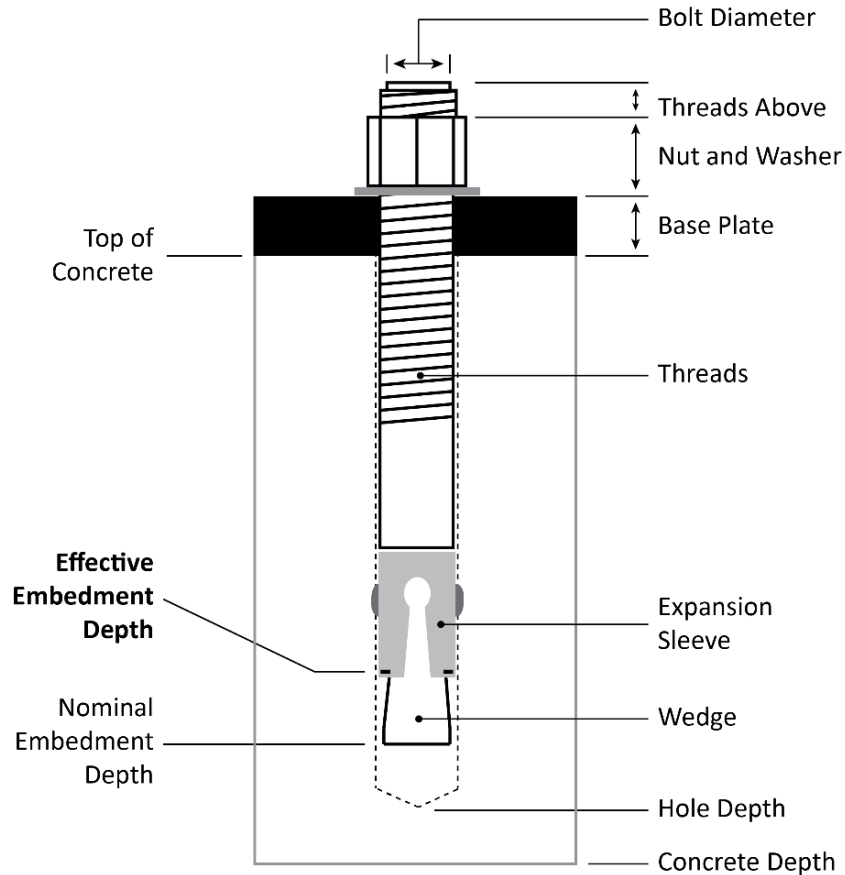

Not necessarily to scale.

The Anchor Bolts shipped with your product have letters stamped into their tops, showing their length.

For example:

- 4.75 in / 120 mm Anchor Bolts are stamped with a **G**.
- 6.3 in / 160 mm Anchor Bolts are stamped with a **J**.

Anchor the Bases

Both Bases have six holes in them for anchoring the Base.

Once the Anchor Bolts are torqued into position, they are not easily removed. BendPak strongly recommends making sure the Bases are in the correct location **before** anchoring them into place.

The following drawing shows the locations of the six Anchor Bolt holes in each P-9000LT Base.

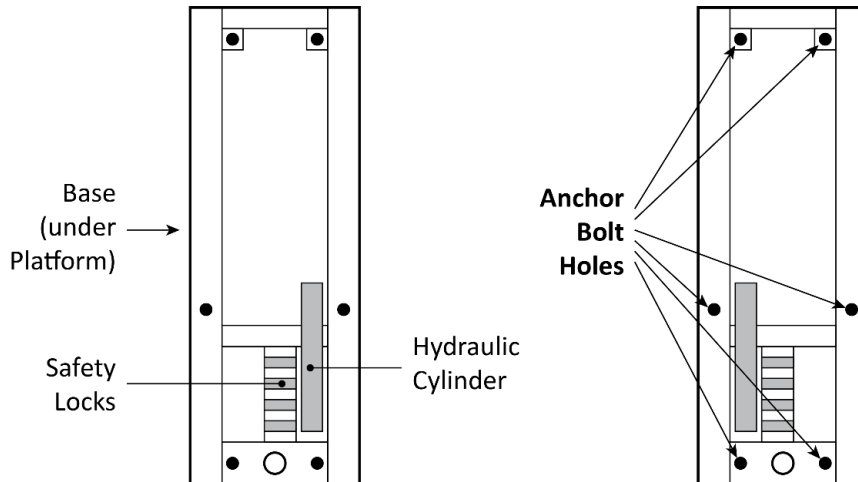

Drawing not necessarily to scale. Not all components shown.

Concrete specifications are:

- **Depth:** 4.25 inches / 108 mm thick, minimum
- **PSI:** 3,000 PSI, minimum
- **Cured:** 28 days, minimum

Anchor Bolt specifications are:

- **Length:** 4.75 inches
- **Diameter:** $\frac{3}{4}$ inch
- **Effective embedment depth:** 2.75 inches, minimum
- **Anchor torque:** 85 – 95 pound feet (not less than 80 or more than 105)

The Concrete floor where you want to install your Lift **must** meet the following requirements:

- The floor must be a flat, Concrete floor. It must be level; **do not install the Lift on a surface with more than 3° slope.**
- Do not install Anchor Bolts into cracked or defective Concrete or on expansion seams. All Anchor Bolts must be at least 6 inches away from expansion seams, control joints, or other inconsistencies in the Concrete.
- Check the floor for the possibility of it being a post-tension slab. In this case, contact the building architect before drilling. Using ground penetrating radar may help you find the tensioned cable.

⚠ WARNING Cutting through a tensioned cable can result in injury or death. Do not drill into a post-tension slab unless the building architect confirms you are **not** going to hit a tensioned cable or you have located it using ground penetrating radar. **If colored sheath comes up during drilling, stop drilling immediately.**

⚠ WARNING **Only use the factory-supplied parts that came with your Lift.** If you use parts from a different source, you void your warranty and compromise the safety of everyone who installs or uses the Lift.

To anchor your Lift:

1. Make sure the Bases are in the correct location.
2. Make sure the Platforms are raised to, and engaged on, the top Safety Lock (this gives you room under the Platform to access the Anchor Bolt holes in the Bases).
3. Using the Anchor Bolt Holes in the Bases as guides, drill each hole **4 in / 101 mm deep**.

Note: If you prefer, you can mark the Anchor Bolt Hole locations, move the Bases out of the way, drill the holes, and then move the Bases back into position.

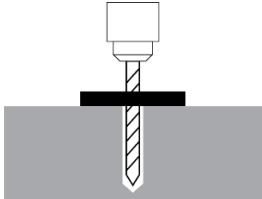

Go in straight; do not let the drill wobble.

Use a carbide bit (conforming to ANSI B212.15).

The diameter of the drill bit **must** be the same as the diameter of the Anchor Bolt. So if you are using a $\frac{3}{4}$ inch diameter Anchor Bolt, for example, use a $\frac{3}{4}$ inch diameter drill bit.

4. Use a vacuum to thoroughly clean each hole.

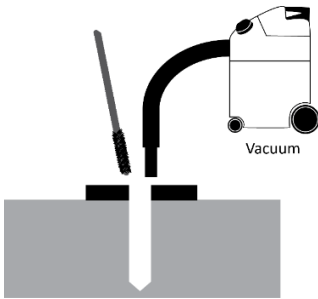

If a vacuum is not available, use a wire brush, hand pump, or compressed air.

Do **not** ream the hole. Do **not** make the hole any wider than the drill bit made it.

Important: You **must** wear OSHA-approved personal protective equipment (such as Safety Glasses) when anchoring the Bases.

5. Make sure the Washer and Nut are in place and flush with the top of the Bolt, then insert the Anchor Bolt into the hole.

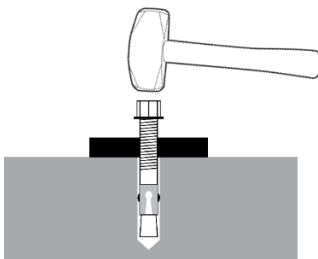

The Expansion Sleeve of the Anchor Bolt may prevent the Anchor Bolt from passing through the hole in the Base; this is normal. Use a hammer or mallet to get the Expansion Sleeve through the Base and down into the hole.

Even using a hammer or mallet, the Anchor Bolt should only go into the hole part of the way; this is normal. If the Anchor Bolt goes all the way in with little or no resistance, the hole is too wide.

6. Hammer or mallet the Anchor Bolt the rest of the way down into the hole.
Stop hammering when the Washer is snug against the Base.
7. Wrench each Nut **clockwise** to the recommended installation torque, **85 – 95 pound feet** (not less than 80 or more than 105), using a Torque Wrench.

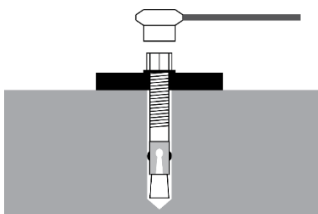

Important: Do **not** use an impact wrench to torque the Anchor Bolts.

Wrenching the Nut forces the wedge up, pushing out the Expansion Sleeve and pressing it tightly against the Concrete.

Set Up the Console and Attach the Power Unit

The Console comes unassembled from the factory.

Note: Some Consoles are occasionally shipped assembled.

The included Hydraulic Hoses require the Console to be within 30 inches of the Lift.



Tip

If you want to set up the Console further than 30 inches from your Lift, you will need to get Hydraulic Hoses that are long enough to reach the Lift from the desired location. You may be able to obtain these lines from the local hydraulics shop, once you know how long you need them. You will also need longer Return and Air Lines.

The following procedure includes instructions for anchoring the Console into place. If you prefer, you can defer anchoring the Console.

Why would you defer anchoring the Console for later? Anchoring the Console is a pretty permanent decision. Delaying the anchoring gives you a chance to evaluate how well you like your first choice for the location of the Console. It is easier to change the Console location later if it is not anchored.

When you want to anchor the Console into place, return to this section and follow the instructions starting with Step 8.

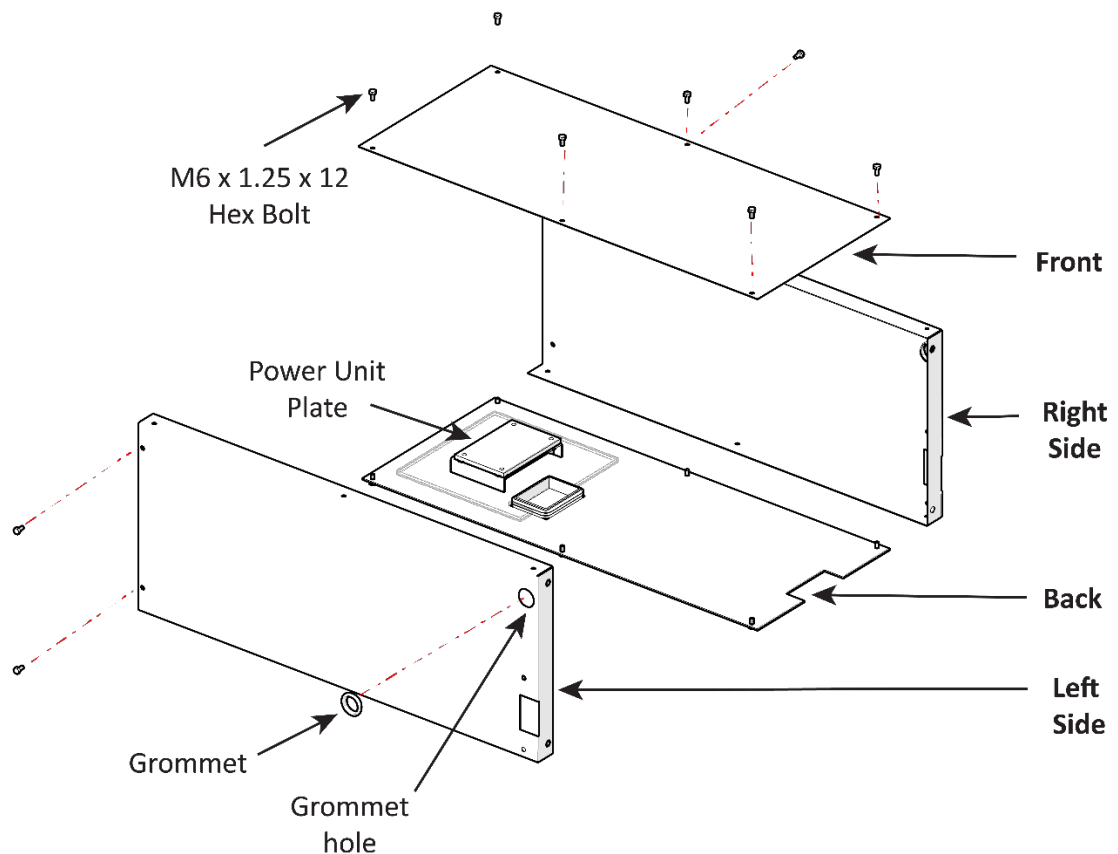

Not to scale. Graphic shows the Power Unit Plate is shown flat on the ground.

To assemble the Console and attach the Power Unit:

1. Select a site for the Console that permits Operators to have a full, unobstructed view of the Lift.
If you are going to use the included Hydraulic Hoses, the Console can go on either side of the Lift (on the end of the Lift with the Hydraulic Cylinders), up to 30 inches away from the closest side.
2. Arrange all of the Console components near where you are going to put it together.
3. Put the Grommets into place in the Grommet Holes on the bottom of the Left and Right Sides.
4. Put the Left Side on the left and the Right Side on the right, then attach both of them to the Back; make sure to orient the Back so that the **Power Unit Plate is on the inside**.

The Back attaches on the *outside* of the two sides.

Do not attach the Nuts at the top of the sides or the Back at this point; these will be attached later when you are ready to attach the cover of the Console.

 **WARNING** When accessing the Power Unit inside the Console for maintenance, do **not** use the Back Panel as the point of entrance; the Power Unit is mounted to the Back Panel. If the Back Panel is removed, the weight of the Power Unit may cause it to fall over and risk product damage and/or personal injury to anyone nearby.

5. Remove the Power Unit from its packing material.
6. Using the supplied Nuts and Bolts, attach the Power Unit to the Power Unit Plate on the inside Back of the Console.

Important: Do **not** make any of the **connections** to the Power Unit at this point.

7. Attach the Front of the Console, then the Cover.

Important: All of the components of the Console are now in place, but they are not all connected. To make connections to the Power Unit, remove both the Console Cover and the Front. Making these connections is described later.

8. If you are ready to anchor the Console, find the holes in the bottoms of the two sides (**on the inside**); the Anchor Bolts go into these holes.

9. Using the holes as a guide, drill two holes 3/8" wide by 2.5" deep into the Concrete.

Go in straight; do not let the drill wobble. Use a carbide bit (conforming to ANSI B212.15).

10. Remove all dust from the holes.

Use a wire brush, vacuum, hand pump, or compressed air. Do **not** ream the hole. Do **not** make the hole any wider than the drill bit made it.

11. Insert an Anchor Bolt with Washer into each hole, then tap it down into the hole.

12. Turn the Anchor Bolt **clockwise** to the recommended installation torque, 50 – 65 pound feet, using a Torque Wrench.

Hydraulic Fluid Contamination

Hydraulic Fluid contamination poses a **serious** issue for your Lift; contaminants such as water, dirt, or other debris can get into the Hydraulic Hoses and Fittings of your Lift, eventually getting into the Hydraulic Fluid. Once debris is in the system, you could experience issues such as one Platform lowering faster than the other, internal and external Hydraulic Fluid leaks, slow operation, and so on.

Your Lift is shipped from the factory with clean components; however, BendPak **strongly** recommends that you give the hydraulic components an extra cleaning. Even a small grain of debris introduced into the Hydraulic System is enough to make the Lift unusable. It is better (and less costly) to take these extra steps now, so that you do not need to take your Lift out of service later to fix issues that could have been prevented.

What you need to do

When you get to the procedure describing how to connect the Hydraulic Hoses, make sure to take a survey of the Hydraulic components that come with your Lift **prior** to making connections. There are several ways to clean the Hydraulic Hoses and Fittings:

- Use an air compressor to blow out contaminants. Clean, dry air is preferred. Keep in mind that the contaminants are going to be coming out the other end, so be prepared for that.
- For Hoses with ends not secured with Fittings, use a projectile cleaning system that shoots expandable cleaning “pellets” through the Hydraulic Hoses to clean them all the way through. HydraCheck, Eaton, and Ultra Clean make these types of systems.
- For Hydraulic Hose ends and Fittings that are not too long, soak part of a rag in the same Hydraulic Fluid, then use the rag to clean out the Fittings and the ends of the Hydraulic Hoses. Do **not** use water or other cleaning fluids, as they should never be mixed with Hydraulic Fluid.

Some additional steps that will help keep your Hydraulic System clean:

- **Always use clean equipment.** If you use a dirty bucket or funnel to transfer the Hydraulic Fluid into the Hydraulic Fluid Reservoir, the contaminants will likely be introduced into the Fluid. When using cleaning rags, use a lint-free rag.
- **Proper Storage.** Keep the Hydraulic Fluid sealed in its container until ready for use; store the fluid in a clean, dry, and cool area.
- **Cover the Hoses and Fittings.** Before installation, do not leave the ends of the Fittings exposed; the same applies for Hydraulic Hoses. As a general rule, keep the Hydraulic Hoses and Fittings capped and kept in a clean area until ready for use.
- **Filter the new Hydraulic Fluid.** Just because it is new does not necessarily mean it is *clean*. Use an offline filtration cart or kidney loop system to make sure the Hydraulic Fluid is clean **before** being transferred into the Hydraulic Fluid Reservoir.
- **Avoid mixing different types of Hydraulic Fluid.** If Hydraulic Fluid needs to be replaced, make sure to flush the Hydraulic System of the old Hydraulic Fluid before you add the replacement fluid; do *not* mix the two together.
- **Remove old thread seal tape.** Some fittings are shipped with temporary plugs secured with thread seal tape, so make sure to thoroughly remove the thread seal tape **before** attaching an NPT Fitting; this prevents pieces of the tape from being pushed into the Hydraulic System. If NPT Fittings on the Hydraulic Cylinders need to be removed or replaced, use a liquid thread sealant.
- **Flush out the Hydraulic System.** Drain the Hydraulic System of the current Hydraulic Fluid, then cycle the Lift a few times using low-viscosity flushing liquid to push out debris trapped in the system; make sure the flushing liquid is compatible with the working fluid.

About Thread Sealants

Liquid Thread Sealant lubricates and fills the gaps between the Fitting threads, and leaves no residue that could contaminate the Hydraulic Fluid.

Other types of Thread Sealants (like Teflon Tape) can shred during installation or removal and eventually enter the Hydraulic System.

Thread Sealant can be used with most Hydraulic Fittings, although you probably only need to use with NPT connectors.

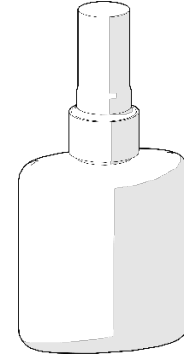

To apply Thread Sealant:

1. Make sure the Fittings and connectors you are going to use are clean and dry.

If you are adding Thread Sealant to a Fitting or connector that has already been used with a different sealant, use a wire brush to thoroughly remove the old sealant before adding more.

2. Apply a small amount of Thread Sealant to the first four threads of the Fitting.

⚠ WARNING Always wear the proper protective equipment when handling Thread Sealant.

You only need a small amount because the sealant spreads to the other threads as it is tightened into place.

If you put too much, the excess liquid will be pushed out when the Fitting is tightened; use a rag to wipe the excess.

3. Tighten the Fitting into the connector; do **not** over tighten the Fitting.
4. Allow the manufacturer-recommended curing time before pressurizing the system.

Connect the Hydraulic Hoses: 208 – 240 VAC only

Hydraulic Hoses route Hydraulic Fluid from the Power Unit to the Hydraulic Cylinders.

Note: Hydraulic Hoses and Fittings are different from Compression Lines and Fittings. ***This section covers Hydraulic Hoses and Fittings only.***

The Lift comes with two Hydraulic Hoses (of the same length), both of which go from a Hydraulic Pressure Port on the Power Unit to one of the Hydraulic Cylinders.

Important: The standard P-9000LT/F Power Unit is 208-240 VAC. These Power Units use two long Hydraulic Hoses to connect to the unit's Hydraulic Cylinders, which is described in this section. 110 VAC Power Units are also available for the P-9000LT/F; these Power Units use a slightly different Hydraulic Hose setup, which is shown and described in **Connect the Hydraulic Hoses: 110 VAC Setup Only**.

The following drawing shows the Hydraulic connections to make to the Frames.

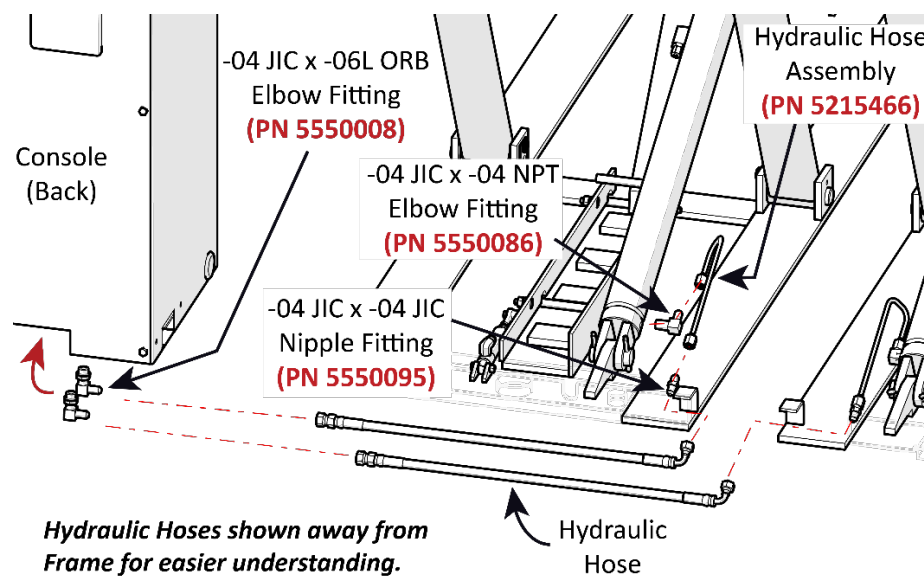

Elbow Fittings (PN 5550008) connect to the Power Unit inside the Console.

Drawing not to scale. Some components not shown for easier understanding.

To connect the Hydraulic Hoses:

1. If the Platforms are not already on their top Safety Locks, raise them now. It is not possible to connect the Hydraulic Hoses if the Platforms are lowered.

Refer to **Lift the Platforms Off the Bases** for additional information.

2. Locate four Hydraulic Elbow Fittings, two Nipple Fittings, two Hydraulic Hoses, and two Hydraulic Hose Assemblies.
3. Prepare the Hydraulic components as described in **Hydraulic Fluid Contamination**.
4. Attach a Hydraulic Elbow Fitting (PN 5550008) to each of the Hydraulic Pressure Ports on the Power Unit.

Depending on your Power Unit, the Port locations may be different. Use the drawing on the following page to identify your layout and then attach your Hydraulic Hoses appropriately.

CAUTION

The Hydraulic Pressure Ports are almost always labeled **P1/P2**; the Hydraulic Return Ports are commonly labeled **T1/T2** or **CV1/CV2**. **Do not accidentally attach a Hydraulic Hose to the Return Line Port.** Your Lift will not work right unless the Hydraulic Hoses and Return Line are attached to the correct Port.

The following drawing shows the possible configurations for your Power Unit.

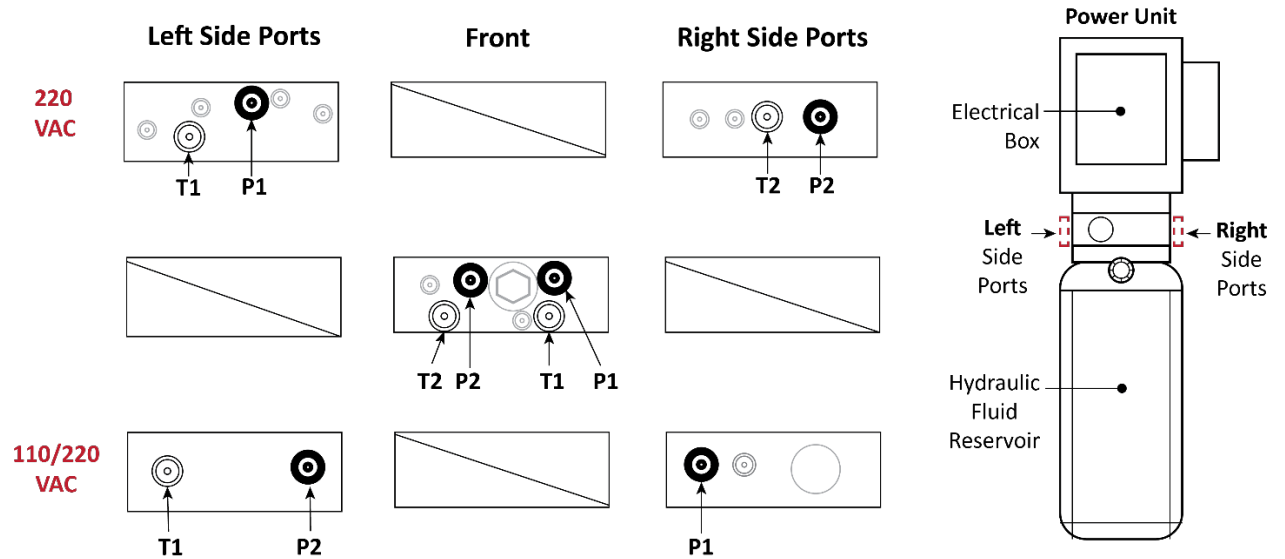

Not drawn to scale. Not all components of the Power Unit shown. Sample Power Unit shown.

- Remove the Shipping Plugs from the Hydraulic Ports near the bottom of each Hydraulic Cylinder, then attach a Hydraulic Elbow Fitting to each Hydraulic Port (as shown below); **use Thread Sealant on the NPT Threads only.**

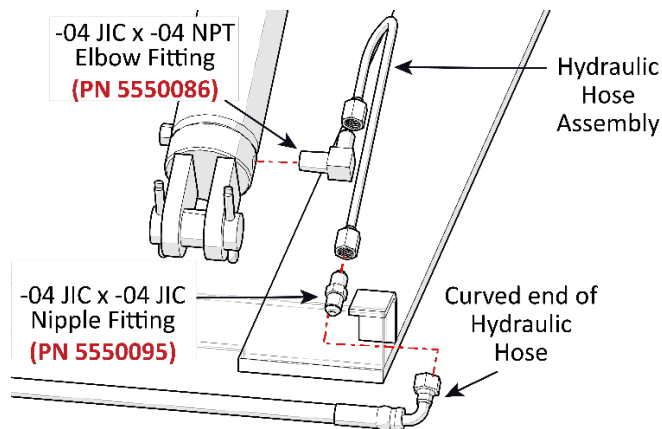

Drawing shows a close up of the Hydraulic Cylinder connections.

Not drawn to scale. Not all components shown.

- Attach the Curved End of the Hydraulic Hose Assembly to the Hydraulic Elbow Fitting you just attached, then attach a Nipple Fitting to the other end of the Hydraulic Hose Assembly.

⚠ CAUTION When installing the Hydraulic Hose Assemblies, make sure they are angled so they end up against or very near to the Hydraulic Cylinders, not standing straight up.

- Attach the Curved end of the Hydraulic Hose to the Nipple Fitting, then route the Hydraulic Hose through the Retaining Rings in the corners of each Base, into an opening in the bottom of the Console, then up to one of the Hydraulic Pressure Ports on the Power Unit.
- When the Hydraulic Hose is correctly routed, connect it at both ends to the appropriate fittings.
- Perform Steps 6 through 9 for the other Hydraulic Hose.
- Make sure both Hydraulic Hoses are correctly routed and do not have any kinks, then use appropriate tools to **securely** tighten the connections.

Connect the Hydraulic Hoses: 110 VAC Setup Only

The 110 VAC Power Units that are available for the P-9000LT/F use a *different Hydraulic Hose setup* than the standard 208-240 VAC Power Units. *This section covers the 110 VAC Power Unit setup.*

The standard 208-240 VAC Power Unit Hydraulic Hose setup is described in [Connect the Hydraulic Hoses](#).

If you ordered a 110 VAC Power Unit with the P-9000LT/F, then the Lift came with one Short Hydraulic Hose and two Long Hydraulic Hoses. These should be configured as shown below.

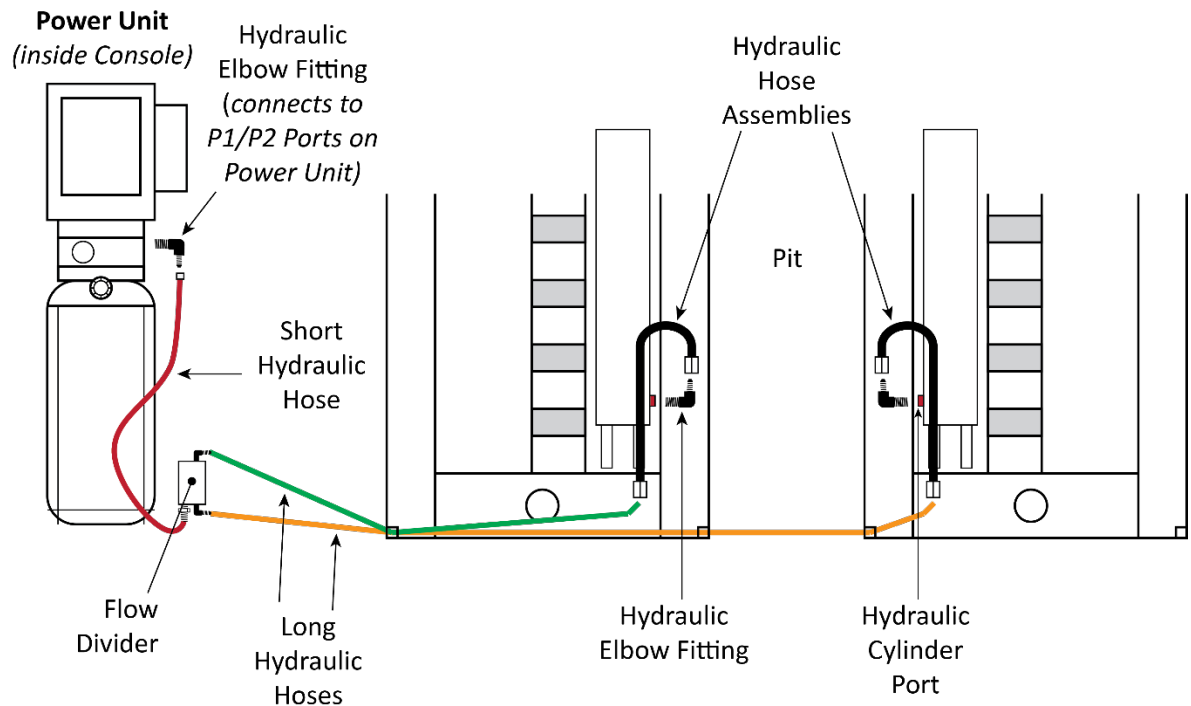

Fittings shown not connected for clarity. Drawing not to scale.

Important: The Hydraulic Hose Assemblies need to be installed up against, or very near to, the Hydraulic Cylinders.

To connect the Hydraulic Hoses:

1. If the Platforms are not already on their top Safety Locks, raise them now and engage them on their top locks. It is not possible to connect the Hydraulic Hoses if the Platforms are lowered.
Refer to [Lift the Platforms Off the Bases](#) for additional information.
2. Locate the Flow Divider, Nipple Fitting, four Hydraulic Elbow Fittings, two Hydraulic Hoses, and two Hydraulic Hose Assemblies.
3. **On the Power Unit**, attach an Hydraulic Elbow Fitting to **one of the two** Hydraulic Pressure Ports on the Power Unit; you can use either one.
Refer to the previous section for more information about the possible Port locations.
4. Connect the Short Hydraulic Hose to the Hydraulic Elbow Fitting you just attached.

5. **Switching to the Flow Divider**, connect the two **Out** Fittings to appropriate Ports (see the drawing below) and then connect the **In** Fitting to its Port.

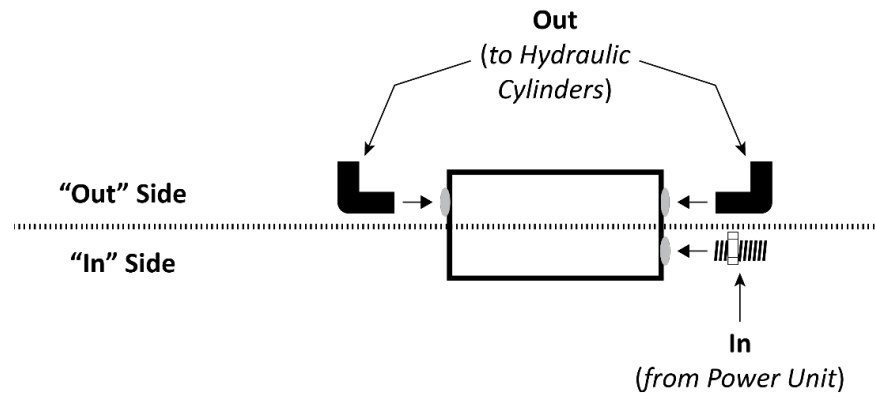

Not drawn to scale. Some components not shown. Fittings shown not connected for clarity.

NOTICE The Ports for the two **Out** Fittings and the **In** Fitting may have colored plugs that need to be removed before you put the Fittings into place.

6. Connect the free end of the Short Hydraulic Hose to the **In** Fitting on the Flow Divider.
7. Connect the two Long Hydraulic Hoses to the two **Out** Fittings on the Flow Divider.
8. **Switching to the Hydraulic Cylinders**, remove the Shipping Plugs from the Hydraulic Ports near the bottom of each Hydraulic Cylinder.
9. Attach a Hydraulic Elbow Fitting to each of the Hydraulic Hose Ports; use Liquid Thread Sealant on the NPT threads **only**.
10. Attach the Curved end of the Hydraulic Hose Assembly to the Elbow Fitting you just attached, then attach a Nipple Fitting to the other end of the Hydraulic Hose Assembly.

CAUTION When installing the Hydraulic Hose Assemblies, make sure they are angled so they end up against or very near to the Hydraulic Cylinders, not standing straight up.

11. Take the free end of the Long Hydraulic Hoses, route them through the Retaining Rings in the corners of each Base, and up to the Nipple Fittings (attached to the Hydraulic Hose Assembly); attach the Hose appropriately.
12. Make sure both Hydraulic Hoses are correctly routed and do not have any kinks, then use appropriate tools to **securely** tighten the finger-tightened connections.

Working with Compression Fittings and Tubing

Your Lift comes with a roll of ¼ inch, black, polyethylene Tubing (also called Poly-Flo® Tubing) that is used with Compression Fittings for the Air Line and the Return Line.

Note: Compression Fittings are different from Hydraulic Fittings. ***This section covers Compression Fittings only.***

The components involved with Compression Fittings include:

- **¼ inch, black, polyethylene Tubing.** The Air and Return Lines require multiple Tubing pieces to make the necessary connections. Create the Tubing pieces by cutting lengths from the long roll of Tubing supplied with your Lift.
- **Straight Compression Fittings.** The Return Line uses two Straight Compression Fittings, one at the top of each Hydraulic Cylinder.
- **Elbow Compression Fittings.** The Air Line uses two Elbow Compression Fittings, one on each Air Cylinder.
- **Tee Compression Fittings.** The Air Line requires one Tee Compression Fitting.
- **Nuts, Ferrules, Rods, and Threads.** Each connector on Straight, Elbow, and Tee Compression Fittings have a Nut, Ferrule, Rod, and Threads (see drawing below). The Nut holds the Tubing and Fitting together. The Ferrule compresses when you tighten the Nut on the Threads to make a secure connection. The Rod goes inside the Tubing so that nothing leaks out.

The following drawing shows the components of a connector on a Tee Compression Fitting.



Important: ***Ferrules can only be tightened once.*** When you tighten the Nut on the Threads, the Ferrule gets compressed; it literally changes shape and ***cannot*** be used again.

To connect Tubing to a Compression Fitting:

1. Push the Tubing through the Nut and over the Rod.
Do not push hard; you only need the Tubing to go a little way over the Rod. You cannot see the Ferrule at this point, but the Tubing must go through the Ferrule and over the Rod.
2. Slide the Nut on the Tubing ***away from the Fitting***, if the Nut is still on the Threads, unscrew it from the Threads and then slide it away from the Fitting. See the drawing above.
3. Slide the Ferrule over the Tubing, away from the Fitting and towards the Nut.
4. With the Nut and the Ferrule out of the way, push the Tubing further over the Rod until it stops.
5. Slide the Ferrule and the Nut back to the Threads on the Fitting.
The Ferrule goes around the Rod and under the Threads. The Nut goes onto the Threads.
6. Tighten the Nut.
Remember that the Ferrule can only be used once; do not tighten the Nut until everything is ready.

Connect the Return Line

The Return Line takes extra Hydraulic Fluid from the Hydraulic Cylinders and returns it to the Power Unit's Hydraulic Fluid Reservoir; it also allows air to move in and out of the Hydraulic Cylinders.

One end of the Return Line connects to the Power Unit. There are two other ends; they attach to Return Line connectors, which are near the top of each Hydraulic Cylinder.

Create the Return Line using the ¼ inch black plastic Tubing that came with the Lift; you need to cut it into sections of the appropriate length.

Important: The Air Line and the Return Line use the same ¼ inch, black, polyethylene Tubing. Be sure not to confuse the two; the Air Line and the Return Line do completely different things and **must** be kept separate from each other.

The following drawing shows how the Return Line can be arranged.

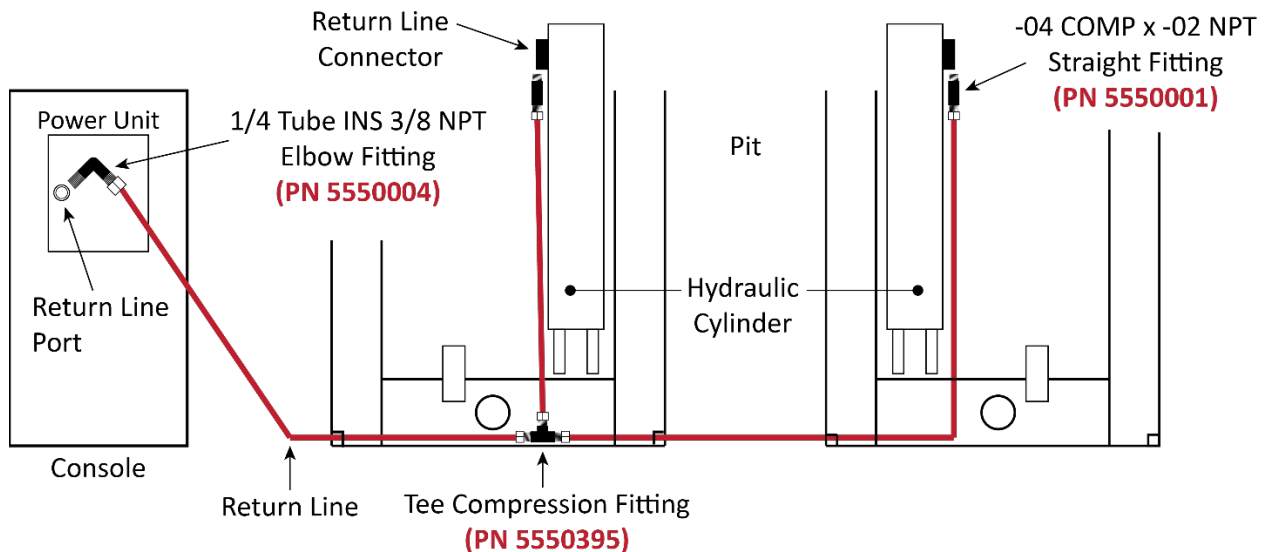

Tip

You can use zip ties (also called cable ties, not supplied) to hold the Return Line in place once the Return Line sections are connected.

To connect the Return Line:

1. Attach an Elbow Compression Fitting (PN 5550004) to *one of the two* Return Line Ports on the Power Unit; **use Liquid Thread Sealant on NPT threads only**.

There are two Return Line Ports on the Power Unit; they work the same, so choose the one that is best for you. **You only need to use one, not both.**

See [Connect the Hydraulic Hoses](#) for the possible Port locations on your Power Unit.

2. Attach a Straight Fitting (PN 5550001) to both Return Line Connectors near the top of each Hydraulic Cylinder.
3. Locate a Tee Compression Fitting (PN 5550395) and put it near the bottom of the Hydraulic Cylinder closest to the Console.
4. Locate the Return Line Tubing, then cut tubing sections of the appropriate length for each of the three Return Line segments.
5. Connect the three Tubing sections between the Fittings.

Connect the Air Line

The Air Line uses air pressure to disengage the Safety Locks so you can lower the Platforms.

Important: It is the responsibility of the Lift owner/operator to provide an air supply (minimum 30 psi at 3 CFM, regulated to a maximum of 125 psi).

CAUTION The Lift uses pneumatic energy. If your organization has Lockout/Tagout policies, make sure to implement them after connecting the Air Line to the air supply.

The air supply is distributed to the Air Cylinders using ¼ inch black plastic Tubing, which is supplied with the Lift. You need to cut the Tubing into appropriate lengths based on the distance between the components you are connecting.

Important: The Air Line and the Return Line use the same ¼ inch, black, polyethylene Tubing. Be sure not to confuse the two; the Air Line and the Return Line do completely different things and **must** be kept separate from each other.

The following drawing shows how to route the Air Line from the Console to the Air Cylinders.

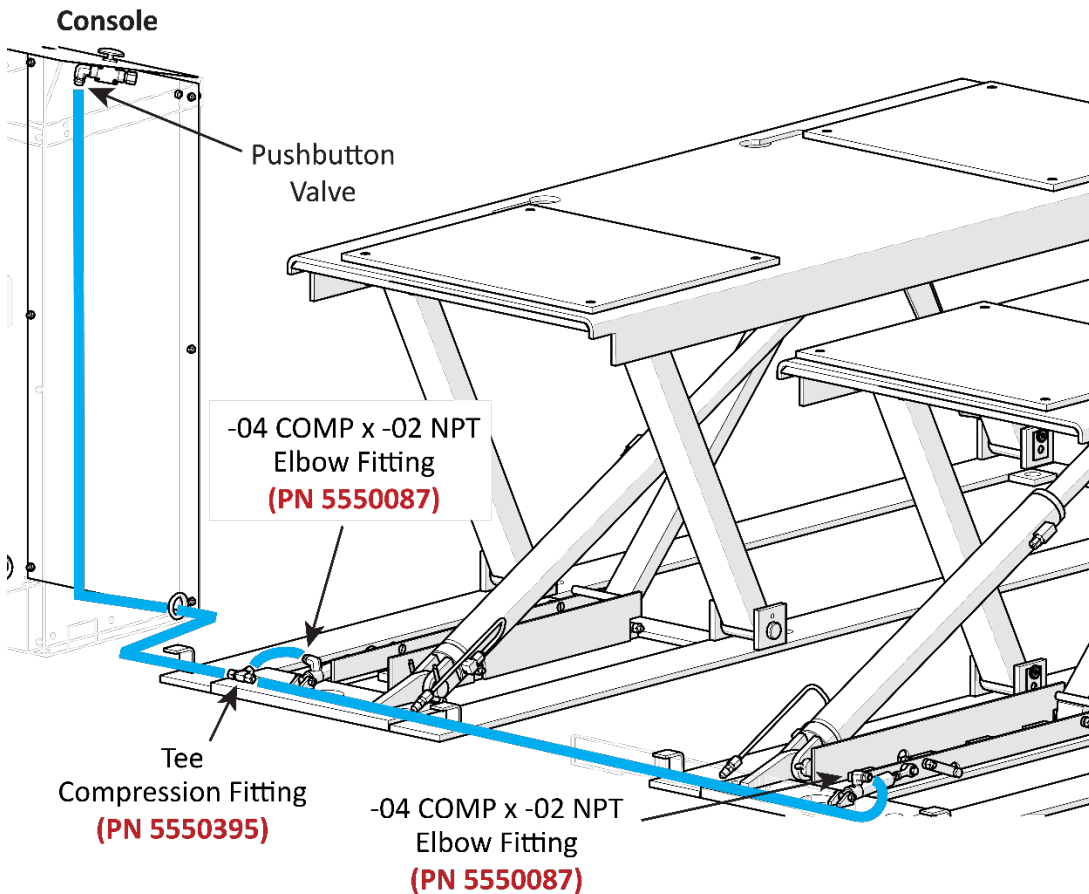

Drawing not to scale. Some components not shown, other components exaggerated for clarity. Console only partially shown.

To connect the Air Line:

1. Locate two Elbow Compression Fittings and connect them on the top of the Air Cylinders.

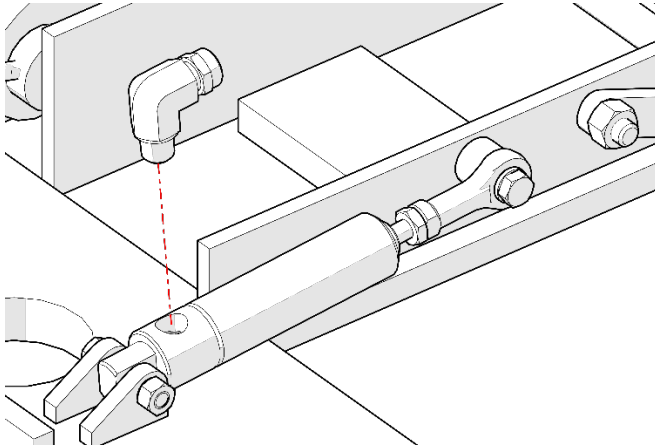

2. Locate the black plastic Tubing and one Tee Compression Fitting and cut the tubing into appropriate lengths for your installation.



Tip

BendPak recommends planning out the path of the Air Line **before** you start cutting the Tubing.

3. Connect the Tubing lengths and the Tee Compression Fitting to the Compression Fittings on the Air Cylinders.
4. On the underside of the Console Cover, attach the male end of a Compression Elbow Fitting to the CYL connector on the Pushbutton Air Valve, then connect the final Tubing length to the compression end of the Elbow Compression Fitting.
5. Also on the underside of the Console Cover, attach the male end of an Air Line Pipe Fitting to the IN connector on the underside of the Pushbutton Air Valve, then connect the customer-supplied air supply to the other end of the Air Line Pipe Fitting.

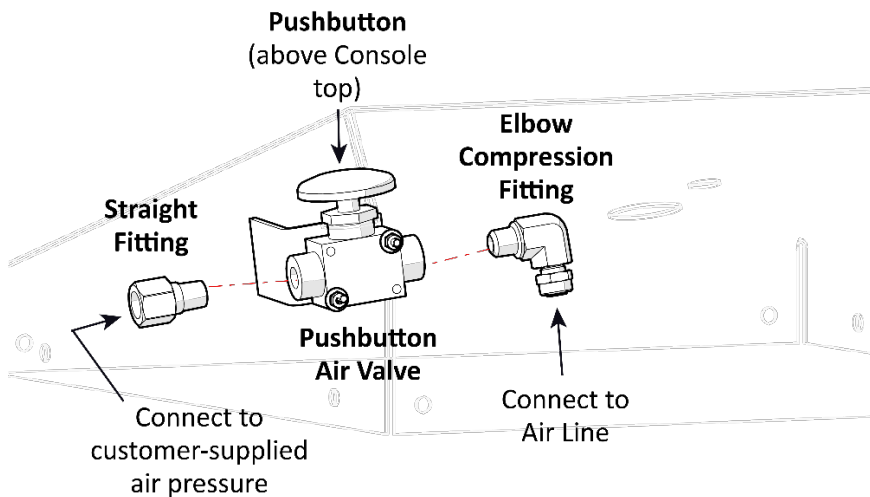

Pushbutton is above the Console Cover, all other components are under the Console Cover. Drawing not necessarily to scale. Not all components shown.

Connect the Buttons

The three Controls for the Lift are located on the Console cover. They do **not** come installed; you must install them.

The three Controls are:

- **Raise button.** Not yet connected, described in this section. Used to raise the Platforms.
- **Lower button.** Not yet connected, described in this section. Used to lower the Platforms.
- **Safety Lock Release button.** Already connected, covered in **Connect the Air Line**. Uses air pressure to push the Platforms off of their Safety Locks so that they can be lowered.

Because the Console and the Power Unit are shipped separately, you connect the Raise and Lower buttons to the underside of the Console cover **after** the Console is assembled and the Power Unit is put in place.

The wiring for the Mini Switch (Lower button) and Microswitch (Raise button) comes connected to the Power Unit from the factory, as shown below.

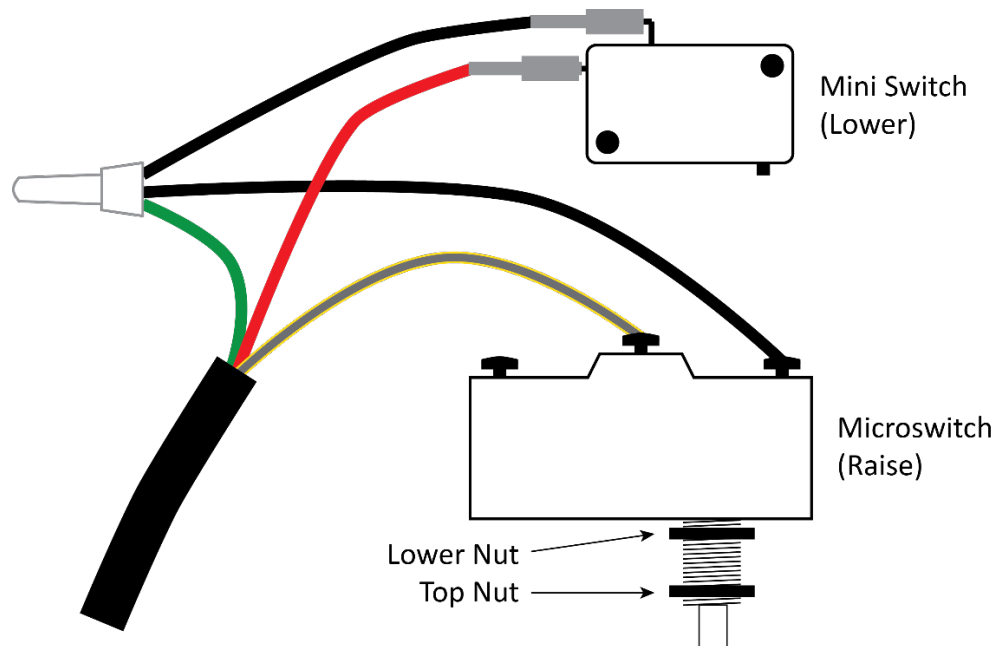

Not necessarily to scale.

If any of the wires are disconnected or missing, refer to **Troubleshooting**.

Do **not** perform the following procedure until the Console is assembled and the Power Unit is installed inside it, covered in **Set Up the Console and Attach the Power Unit**.

To connect the Controls:

1. Remove the front of the Console if it is currently in place.
2. On the Console Cover, note the locations of the Raise and Lower controls, then turn the Console Cover upside down. Use care, the Air Line and the incoming air supply are connected.
3. Locate the Microswitch (connected to the wiring on the Power Unit) and the Button Guard.
4. Take the Top Nut off of the threads on the Microswitch.
5. Put the Microswitch and Lower Nut into place through the Console Cover.

The Microswitch is the Raise button.

6. Holding the Microswitch and the Lower Nut in place, turn the Console Cover right side up.
7. Put the Button Guard into position around the button portion of the Microswitch (through the hole in the bottom of the Button Guard).
8. Put the Top Nut back into position on the threads on the Microswitch, then tighten it.

The following drawing shows how the Button Guard and the Microswitch go together.

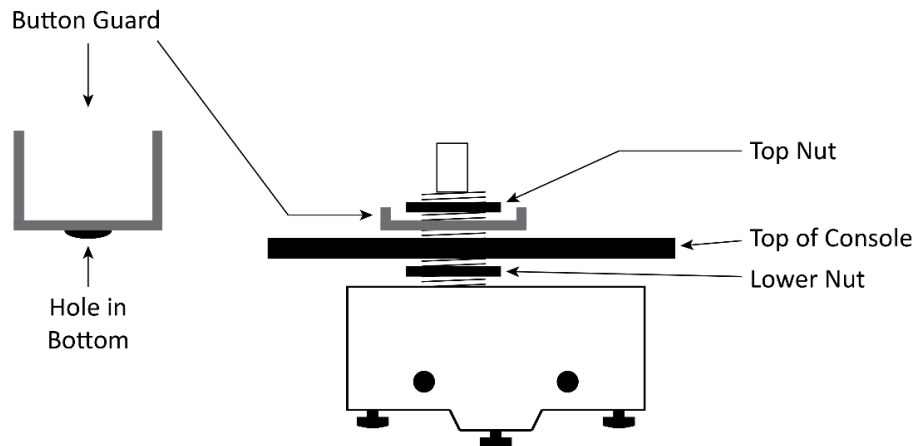

9. With the Console Cover still right side up, locate the Black Button, then remove the black plastic Nut and Washer from the Black Button.
10. Put the Black Button into the hole for the Lower button in the Console Cover.
11. Holding the Black Button in place, turn the Console Cover upside down again, put the black plastic Nut and Washer back into place on the threads of the Black Button, then tighten them.
12. Take the Mini Switch and carefully push it into place at the bottom of the Black Button.

Make sure the protruding pieces on the bottom of the Black Button go into the holes in the Mini Switch; the Mini Switch will **not** work correctly until the protruding pieces are in the holes. You **may** need to bend back the section holding the protruding pieces to seat the Mini Switch.

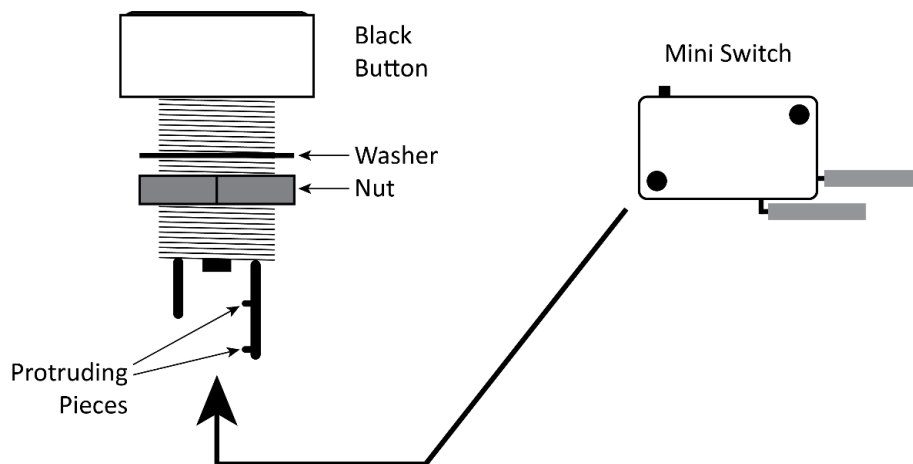

13. Turn the Console Cover right side up, then secure it in place.

Connect to Power

This section describes how to connect your 208-240 VAC Power Unit to a power source.

If you have the optional 110 VAC Power Unit, plug it in to an appropriate 110 VAC outlet.

Do not connect the Power Unit to a power source unless the Raise and Lower buttons are already connected to the Power Unit.

⚠ DANGER If you connect the Power Unit to its power source *before* connecting the Raise and Lower Buttons, there is a small chance you could be electrocuted! To avoid even this small chance, make sure to connect the Raise and Lower Buttons to the Console *before* connecting the Power Unit to its power source. **Failure to follow this instruction could result in serious injury or death.**

BendPak recommends a 30 amp or greater breaker for the standard Power Unit; check with your Electrician to confirm this is appropriate for *your* installation and is consistent with all applicable electrical codes.

⚠ DANGER All wiring *must* be performed by a licensed, certified Electrician.

Most customers have their Electrician:

- Wire the Lift directly into the facility's electrical system, *or*
- Add a power cord with appropriate plug, which is then plugged in to an appropriate power source.

The Electrician will need to provide the necessary components; they are *not* supplied with the Lift.

All Power Units come with a 'pigtail' coming out of the Electrical Box. When connecting to the power source, **remove the pigtail** from inside the Electrical Box, then connect directly from inside the Electrical Box to the electrical system at your location or to an appropriate power cord with plug.

Refer to **Wiring Diagrams** for Power Unit wiring information.

Important electrical information:

- Improper electrical installation can damage the Power Unit motor; this damage is *not* covered under warranty.
- **All** electrical work *must* conform to applicable local, state, and federal codes, rules, and regulations, such as state and federal OSHA regulations and electrical codes.
- All wiring must be done in accordance with National Electric Code and local codes and standards covering electrical apparatus and wiring.
- The Lift uses electrical energy. If your organization has Lockout/Tagout policies, make sure to implement them after connecting the Power Unit to a power source.
- Use a separate circuit breaker for each Power Unit.
- Protect each circuit with a time-delay fuse or circuit breaker

⚠ DANGER Risk of explosion: The Power Unit has internal arcing or parts that may spark and should not be exposed to flammable vapors. The Power Unit's motor should not be located in a recessed area or below floor level. Never expose the motor to rain or dampness; damage to the motor caused by water is *not* covered by the warranty.

To connect to a 208-240 VAC power source:

1. Remove the front of the Console if it is currently in place. You need to access the Power Unit.
2. Locate the Pigtail coming out of the Electrical Box on the Power Unit.
3. Open the Electrical Box, note where each wire is connected, remove the Pigtail, and then either:
 - Wire the Power Unit directly into the facility's electrical system, **or**
 - Wire a power cord with appropriate plug starting inside the Electrical box where the Pigtail was wired.

You can find the Wiring Diagram for your Power Unit in [Wiring Diagrams](#).

4. Close the Electrical Box.
5. If you wired a power cord with plug, plug it in to an appropriate power outlet.

Install a Power Disconnect Switch

 **WARNING** A Power Disconnect Switch is **not** provided with this equipment.

A Power Disconnect Switch is a National Electrical Code (NEC) requirement. They are designed to interrupt main electrical power in the event of an electrical circuit fault, emergency situation, or when equipment is undergoing service or maintenance.

Make sure to install a Power Disconnect Switch that is properly rated for the incoming power source.

Your Power Disconnect Switch must be installed so that it is in **easy reach of the Operator** or in their line of sight. The Power Disconnect Switch must be **clearly marked** to indicate its purpose.

If you are not clear where to put the Power Disconnect Switch, consult with your Electrician.

 **DANGER** Installing a Thermal Disconnect Switch **must** be performed by a licensed, certified Electrician.

Have the Electrician select a **UL-listed** Power Disconnect Switch.

Install a Thermal Disconnect Switch

 **WARNING** The motor on the Power Unit has **no thermal overload protection**.

Have the Electrician connect a motor Thermal Disconnect Switch or overload device that will make sure the equipment shuts down in the event of an overload or an overheated motor.

 **DANGER** Installing a Thermal Disconnect Switch **must** be performed by a licensed, certified Electrician. Do not perform **any** maintenance or installation on the Lift without first making sure that main electrical power has been disconnected from the Lift and **cannot** be re-energized until all procedures are complete.

High running amps that exceed the motor's full load amps (FLA) rating may result in permanent damage to the motor. **Do not exceed the rated duty cycle of the motor.**

Adding Hydraulic Fluid

The Hydraulic Fluid reservoir on the Power Unit must be filled with Hydraulic Fluid or automatic transmission fluid **before** you begin normal operation of the Lift. ***When you receive the Lift, the fluid reservoir is empty.***

The Power Unit will not work correctly until the reservoir is filled with approved Hydraulic Fluid.

Approved fluids are any general purpose ISO-32, ISO-46, or ISO-68 Hydraulic Fluid, approved automatic transmission fluids such as Dexron III, Dexron VI, Mercon V, Mercon LV, or any synthetic multi-Vehicle automatic transmission fluid.

⚠ WARNING Do not run your Power Unit without Hydraulic Fluid; you will damage it.

To fill the Hydraulic Fluid Reservoir:

1. Remove the Reservoir Cap from the top of the Hydraulic Fluid Reservoir.

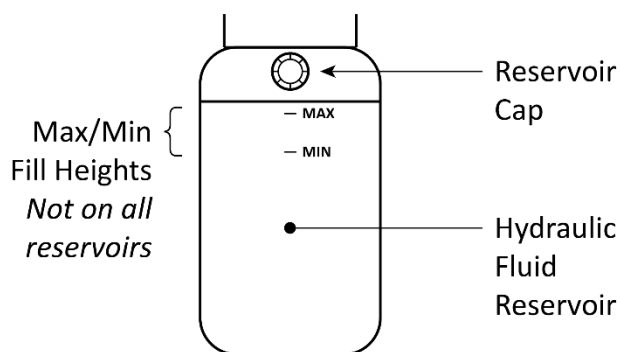

Not necessarily to scale. Not all components shown.

2. If the Hydraulic Fluid Reservoir is **not** full, fill it with approved fluid.

The Reservoir holds approximately 1.5 gallons / 5.5 liters. Use care to keep the fluid clean when filling the Reservoir.

Important: The Power Units currently shipping with the P-9000LT/F hold approximately 1.5 gallons / 5.5 liters of Hydraulic Fluid. If different Power Units are substituted in the future, which occasionally happens, you could end up with a Power Unit with a different sized Hydraulic Fluid Reservoir. If 1.5 gallons / 5.5 liters does not seem like an appropriate amount of Hydraulic Fluid for the Reservoir on your Power Unit, fill the Reservoir up to the MAX line on the Reservoir or to .5 in / 12.5 mm under the Reservoir Cap instead.

Approved fluids are any general purpose ISO-32, ISO-46, or ISO-68 hydraulic fluid or approved automatic transmission fluids such as Dexron III, Dexron VI, Mercon V, Mercon LV, or any synthetic multi-Vehicle automatic transmission fluid.

3. If the Reservoir is low, add approved fluid until the fluid level is at least at the minimum level; maximum level is best.

If your Reservoir does not have MAX/MIN markings, full is approximately .5 in / 12.5 mm under the Reservoir Cap.

4. When the Reservoir is filled, put the Reservoir Cap back on.

Final Checklist Before Operation

Make sure these things have been done **before** using your Lift:

- Review the **Installation Checklist** to make sure all steps have been performed.
- Make sure the Power Unit is getting power from the power source.
- Check the Hydraulic Fluid Reservoir; it must be full of approved Hydraulic Fluid or automatic transmission fluid. **You can harm the motor by running it without enough fluid.**
- Check the Hydraulic System for leaks. Check for any loose Hydraulic Fittings and Auxiliary Port Plugs. Inspect for pinched or damaged Hydraulic Hoses and replace them **before** operation.
- Check to see that all Anchor Bolts are appropriately shimmed and correctly torqued.
- Make sure nothing is interfering with the Safety Locks; they must **not** be blocked in any way.
- Leave the *Installation and Operation Manual* with the owner/operator. It needs to be available to anyone who operates, maintains, or troubleshoots the Lift.

Test the Lift

Before putting your Lift into normal operation, we recommend raising and lowering it two or three times. This will test the Lift's functionality, help you get a feel for how to operate the controls, and help get any residual air out of the Hydraulic System.



Tip

Residual air in the Hydraulic System can cause the Lift to shake, move erratically, or squeak; this is normal when you first start using the Lift. It will soon stop doing this, as the Hydraulic System is self-bleeding.

The Ramps do not need to be installed to test the Lift, nor do you need a Vehicle on it.

To test your Lift:

1. Check the area around and above the Lift for obstructions; move them away if you find any.
2. Place the Lift Blocks under the manufacturer's recommended Lifting Points of the Vehicle.
3. Press and hold **Raise**; the Platforms begin raising.
4. When the Platforms move past the first Safety Lock, release **Raise**; the Platforms stop rising.

You do not need to engage the Platforms on the Safety Lock.

5. Press and hold **Safety Lock Release** and **Lower**; the Platforms start lowering.

Note: Without the weight of a Vehicle, the Lift may raise or lower slower than it will when it does have the weight of a Vehicle on it.

6. When the Platforms get to the ground, they will stop; release **Safety Lock Release** and **Lower**.
7. Wait for one minute.

 **WARNING** The Power Unit is not a constant duty motor; **it cannot be run continuously.**

8. Repeat the process, this time raising the Lift to the top Safety Lock and then lowering it back down to the ground.
9. If the Lift is working without shaking, moving erratically, or squeaking, there is no need to repeat the procedure.

If the Lift is shaking, moving erratically, or squeaking, repeat the procedure one more time, this time with a Vehicle on the Lift.

If you continue to have issues, refer to [Troubleshooting](#) for assistance.

Add the Ramps

The Lift comes with four Ramps: two Long Ramps and two Short Ramps. The P-9000LT**F** does not come with any Ramps, as it is a flush mount.

The standard configuration is for the Short Ramps to be installed next to the Hinged Ramps and the Long Ramps to be installed on the other end of the Base.

This configuration creates a flat, *extended* Platform onto which you drive the Vehicle to be raised. The extended Platform keeps the Vehicle flat and well above the Platforms, making it easy to position the Lift Blocks under the manufacturer-recommended Lifting Points.

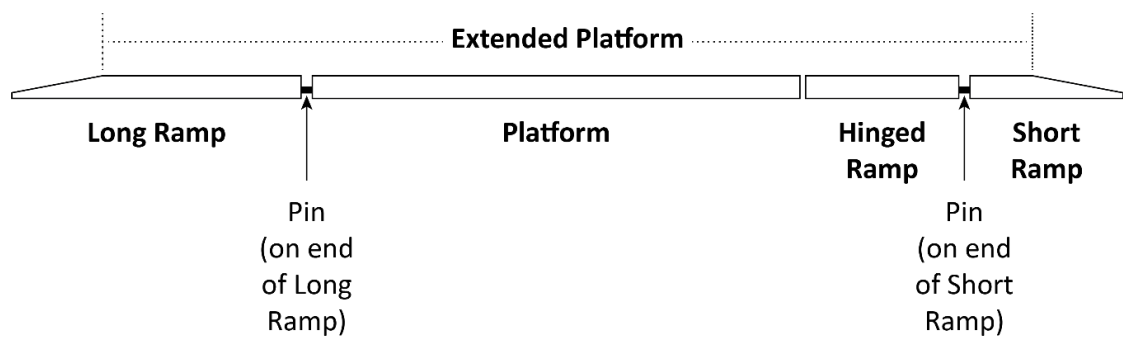

Not necessarily to scale. Not all components shown. Side view.

All four Ramps come with pins that fit into holes in the Base. To put a Ramp into position, put the pins into the holes in the Base and make sure they are correctly seated.

Operation

This section describes how to operate your Lift.

⚠ DANGER When you even hear the words “automotive lift,” you need to remember that being in close proximity to one is a serious endeavor with potentially life-threatening risks. Only allow trained, authorized, supervised personnel near the Lift. **Do not assume you are going to be safe this time just because nothing happened last time.**

Safety First

BendPak strongly recommends referring to the ANSI/ALI ALIS Standard *Safety Requirements for Installation and Service* for more information about safely using your Lift.

Before you raise or lower a Vehicle using your Lift, do the following:

- **Check the Lift.** Check the Lift for any missing, heavily worn, or damaged parts. Do not operate the Lift if you find any issues. Instead, take it out of service, then contact your dealer, email support@bendpak.com, visit bendpak.com/support, or call **(800) 253-2363**, x196.
- **Check the area.** Check the area around the Lift for obstructions; anything that might block the Lift. Do not forget to check **above** the Lift. If you find an obstruction, move it out of the way. Do not allow anyone within 30 feet of the Lift while it is being used.
- **Check the operators.** Make sure everyone who is going to operate the Lift has been trained in its use, has read the labels on the unit, has read the manual, and is properly supervised. Only the Operator at the Console should be within 30 feet of the Lift when it is being used.
- **Check for safety.** Make sure everyone who is going to be walking near the Lift is aware of its presence and takes appropriate safety measures. Only put Vehicles on the Lift. **When raising the Lift, do not leave it until it is engaged on Safety Locks.** When lowering the Lift, do not leave it until it is fully lowered. Do not allow children to operate the Lift. Do not allow anyone under the influence of drugs or alcohol to operate the Lift.
- **Check the Vehicle.** Never exceed the Lift’s rated capacity. Do not allow people inside a Vehicle you are raising. Make sure Vehicles are not overbalanced on either end. Make sure you know and use the manufacturer-recommended Lifting Points for the Vehicle. Never raise just one side, one corner, or one end of a Vehicle. Make sure the weight of the Vehicle is evenly distributed, both between front and back and side to side.

Anything that could impact the safe use of the Lift **must** be fully resolved before you use the Lift. Only use the Lift if it can be used **safely**.

The Console

Operation of the Lift is controlled via the Controls on the Console.



The Controls on the Console are:

- **Safety Lock Release** button. Uses air pressure to push up the Safety Release Bar, which allows the Platforms to lower.
- **Raise** button. Moves the Platforms up.
- **Lower** button. Moves the Platforms down, either all of the way down to the ground or onto a Safety Lock.

About Safety Locks

Your Lift comes with multiple Safety Lock positions; they serve two important functions:

- **Safety.** Safety Locks hold the P-9000LT/F Platforms in place. Once the P-9000LT platforms are engaged on Safety Locks, the weight of the Vehicle holds the Platforms in place. If the power goes out or the Hydraulic Hoses are cut or start to leak, the Safety Lock holds the P-9000LT Platforms, and anything on them, in place.

⚠ WARNING Always leave your P-9000LT/F Platforms engaged on the Safety Locks or lowered to the ground. Although rare, it is possible for Hydraulic Fluid in the Hydraulic Cylinders to leak, causing the Platforms to slowly come down. **Always leave it your Lift either fully lowered or engaged on Safety Locks.**

- **Adjustable height.** Having multiple Safety Locks means you can raise the Vehicle to just the right height for the work you are performing.

The following drawing shows the Safety Lock mechanism on one P-9000LT/F Platform.

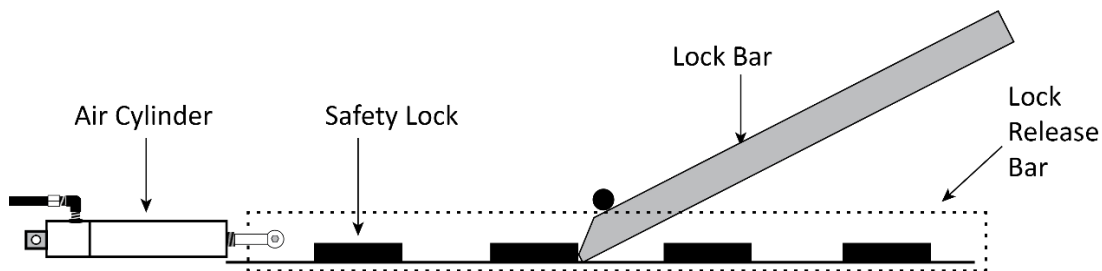

Not necessarily to scale. Not all components shown. Lock Release Bar is shown by a dashed line so the Safety Locks can be seen.

The following drawing shows the positions the Lock Bar can be during normal operation.

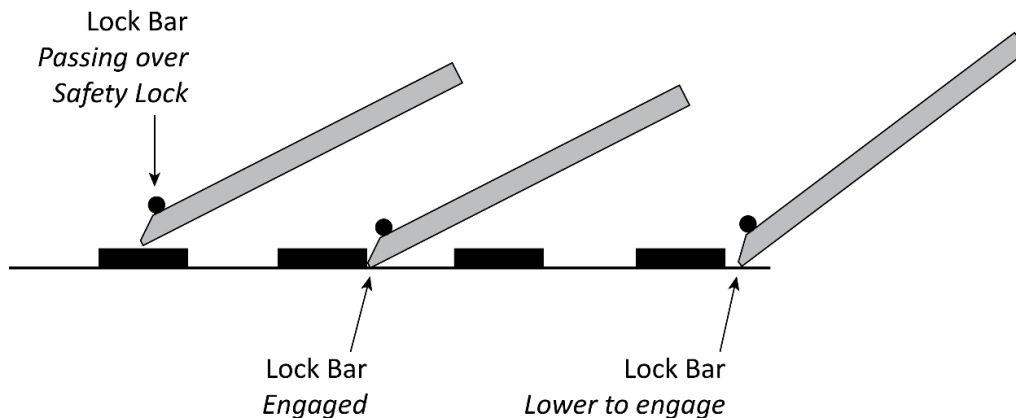

The three positions are:

- **Passing over a Safety Lock.** The Platforms are not engaged on Safety Locks when they are passing over a Safety Lock. You will know when the Lock Bar has passed a Safety Lock by the loud clank sound it makes.
- **Engaged on a Safety Lock.** When engaged on Safety Locks, the Lift's Platforms are secure and will be held in place by the weight of the Vehicle on the Lift.
- **Past a Safety Lock.** When the Lock Bar passes a Safety Lock, it is in the right position to be lowered back down into an engaged position.

Raising a Vehicle

This section describes how to position a Vehicle on the Lift and raise it.

Important Do not remove a Vehicle's tires and then lower the Vehicle all the way to the ground. The Lift requires some space between the ground and the underside of your Vehicle to build up enough force to raise the Vehicle.

⚠ WARNING Never raise a Vehicle whose weight exceeds the rated capacity of the Lift. Do not leave the Controls until the Lift is engaged on Safety Locks or fully lowered. Only trained personnel should raise and lower the Lift. Only the Operator should be within 30 feet of the Lift when it is in use.

To raise a Vehicle:

1. Check the items listed in **Safety First**.

If you find any issues, resolve them **before** attempting to raise a Vehicle.

2. Make sure both Platforms are fully lowered.
3. Drive the Vehicle onto the Platforms—the wheels should be centered on the Extended Platform.

⚠ CAUTION Make sure to situate the Vehicle so that neither the front nor the rear wheels are over the Platforms. If you raise the Platforms with the wheels over the Platforms, you could damage the wheels.

4. Put the Vehicle in park, put on the parking brake, and turn off the Vehicle.

If the Vehicle is a manual transmission, put it into first gear before turning it off.

5. Walk around the Vehicle to make sure there are no obstructions or any other issues that will interfere with the raising or lowering of the Platforms.
6. Place the Lift Blocks under the factory-recommended Lifting Points of the Vehicle.

⚠ WARNING Do not 'eyeball' the best location for the Lift Blocks. **You must use the manufacturer-recommended Lifting Points.** If you do not know the factory-recommended Lifting Points for the Vehicle, use *Vehicle Lifting Points for Frame-Engaging Lift* and SAE Standard J2184, *Vehicle Lift Points for Service Garage Lifting*, as resources to assist you in the proper positioning of a Vehicle for raising. If the Vehicle has an additional or uniquely positioned payload, have a qualified person calculate the Vehicle's center of gravity or have the Vehicle's center of gravity determined at a Vehicle scale.

7. At the Console, press and hold the **Raise** button; the Platforms start rising.
8. Just **before** the Lift Blocks make contact with the Lifting Points on the Vehicle, release **Raise**; the Platforms stop.

Check the locations where the Lift Blocks will hit the factory-recommended Lifting Points on the Vehicle. If necessary, adjust the Lift Blocks so they are properly positioned under the Lifting Points (you may need to lower the Vehicle some to adjust the Lift Blocks).

9. After confirming the Lift Blocks are properly positioned, press **Raise**; the Platforms start going up again and the Lift Blocks contact the Vehicle's Lifting Points.

⚠ WARNING If the Lift becomes unstable, release the **Raise** button and immediately evacuate the area. If safe to do so, carefully lower the Platforms back down to the ground.

-
10. Release **Raise** when the Vehicle's wheels are about 6 in / 152 mm off the ground; the Platforms stop.
 11. Make sure all four Lift Blocks are in firm contact with the factory-recommended Lifting Points.
If the Lift Blocks **are** in the right positions, do not move them.
If the Lift Blocks are **not** in the right positions, press and hold **Lower** and **carefully** return the Vehicle to the ground, then restart the process from the beginning.
 12. If the Lift Blocks are in the right positions, rock the Vehicle gently to test for stability.
If the Vehicle is stable, press and hold **Raise** to continue raising Vehicle.
If the Vehicle is **not** stable, press **Lower** and **carefully** return the Vehicle to the ground, then start the raising process from the beginning.
 13. To engage both Platforms on Safety Locks, raise the Vehicle just past the desired Safety Lock (you will hear a clank when it passes), release **Raise**, then press **Lower**.
The Platforms will stop moving down when they engage on the Safety Locks; release **Lower**.
-  **WARNING** Before doing anything else (like working on the Vehicle or leaving the area), **visually confirm** that **both** Platforms are engaged on the same Safety Locks and all Lift Blocks are in stable contact with the Vehicle's factory-recommended Lifting Points.
14. Confirm that both Platforms are engaged on the same Safety Locks and that all Lift Blocks are in stable contact with the Vehicle's factory-recommended Lifting Points.

Lowering a Vehicle

This section describes how to lower a Vehicle from a raised position.

-  **WARNING** **Never** lower a Vehicle all the way to the floor with the wheels removed. Failure to comply with these instructions will void the product warranty. BendPak assumes no liability for loss of damage of any kind resulting from improper installation or use of this product.

To lower a Vehicle:

1. Check the items listed in **Safety First**.
If you find any issues, resolve them **before** attempting to lower a Vehicle.
 2. At the Console, press and hold the **Raise** button for a couple of seconds.
This moves the Platforms off the Safety Locks, which is required for them to lower.
 3. Press and hold the **Safety Lock Release** button, then press and hold the **Lower** button.
Pressing and holding the **Safety Lock Release** button causes the Air Cylinder to push up and hold up the Lock Release Bar, preventing the Lock Bar from engaging on Safety Locks as the Platforms lower. If you do not press and hold the **Safety Lock Release** button, the Platforms will engage on the closest Safety Lock instead of lowering.
-  **WARNING** If the Lift becomes unstable at any point before it is fully lowered to the ground, release the **Lower** button and immediately evacuate the area. If safe to do so, return to the Console and carefully lower the Platforms back down to the ground.
4. When the Platforms are fully lowered, release both buttons.

Lift Arm Kit

The P-9000LT/F has an optional Lift Arm Kit available.

The Lift Arms increase the capabilities of your Lift. The pads and extenders let you quickly and easily hit the lifting points of cars, light trucks, and SUVs. If you are using your P-9000LT/F in a pit environment, the Lift Arms install over your pit without interfering with your lube bay opening.

The Lift Arm Kit includes:

- Four telescoping Lift Arms
- Four round rubber pads
- Four extensions
- Four Safety Stop Bushings

Together, the Lift Arms can raise up to 9,000 pounds (4,082 kilograms). The Lift Arms are designed to be used together to raise a Vehicle; **do not use the Lift Arms separately.**

If you extend the Lift Arms (using their telescoping ability) past four inches from the edge of the Platform, the rated capacity of the Lift Arms is reduced:

- **Up to four inches:** 2,250 lbs per Lift Arm, 9,000 lbs total. *No reduction in rated capacity.*
- **At six inches:** 1,500 lbs per Lift Arm, 6,000 lbs total.
- **At 10 inches:** 900 lbs per Lift Arm, 3,600 lbs total.
- **At 18 inches (fully extended):** 500 lbs per Lift Arm, 2,000 lbs total.

⚠ WARNING Do not overload the Lift Arms. If you try to raise a Vehicle that is over the rated capacity, you could damage the Lift or the Lift Arms. Also, the Vehicle could fall, possibly damaging the Vehicle or causing serious bodily injury, even death.

To install the Lift Arms:

1. Move the first Lift Arm into place on top of the Platform, with the non-telescoping end above the hole on the Platform you want to install it into.

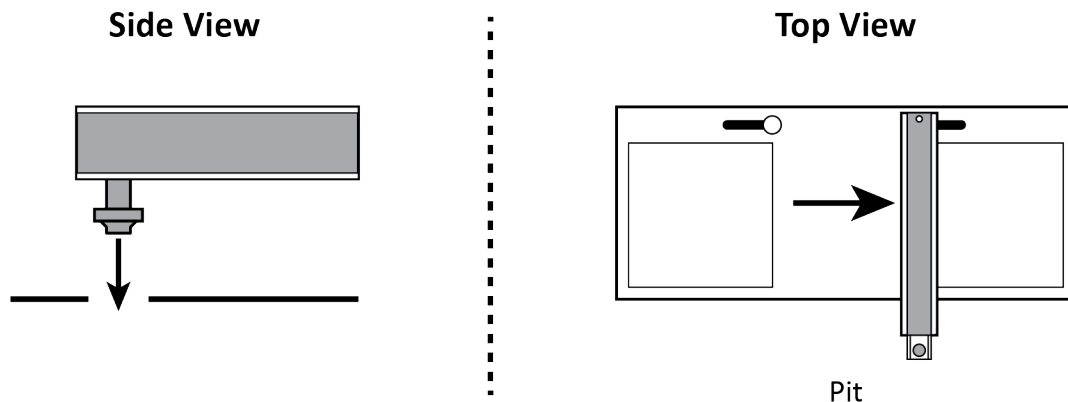

⚠ CAUTION Be careful with the Lift Arms; they are heavy and you can pinch your fingers. BendPak recommends wearing gloves when installing or moving the Lift Arms.

2. Put the flange on the bottom of the Lift Arm into the hole, then move the Lift Arm over into the narrower section of the hole.

- Put the Safety Stop Bushing into the hole and firmly press it into place.

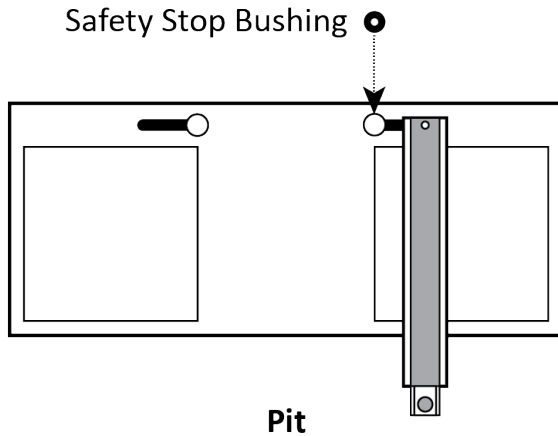

Important: Do not use any of the Lift Arms unless **all four** of the Safety Stop bushings are in place.

- Repeat Steps 1 through 3 for the other Lift Arms.

⚠ WARNING Never move the inside edges of the Lift Arms past the corners of the Platform. They are not designed to hold weight past the inside edges; you could damage the Lift or the Lift Arms.

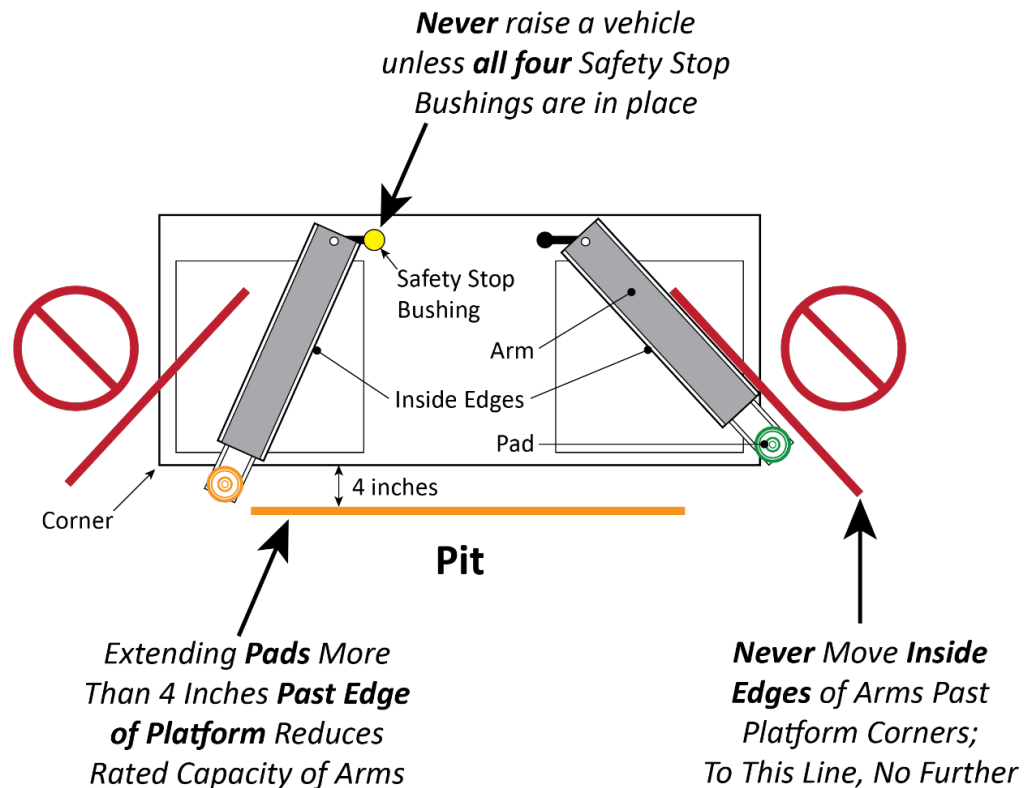

Maintenance

 **DANGER** Before performing any maintenance, make sure the Lift is completely disconnected from power and **cannot** be re-energized until all maintenance is complete. BendPak strongly recommends using your Power Disconnect Switch during maintenance. The Lift uses electrical and pneumatic energy; if your organization has Lockout/Tagout policies, implement them **before** performing any maintenance.

To maintain your Lift:

- **Daily:** Keep the Lift clean. Wipe up any oil spills, clean any dirt.
- **Daily:** Make a visual inspection of all moving parts and check for damage or excessive wear. If you find any damaged or worn parts, take the Lift out of service until they are replaced.
- **Daily:** Make sure the Safety Locks are in good operating condition. If you find that the Safety Locks are damaged or excessively worn, take the Lift out of service until they are replaced. **Do not use your Lift if the Safety Locks are damaged or excessively worn.**
- **Weekly:** Check all controls to make sure they are functioning normally.
- **Weekly:** Check all labels on the unit. Replace them if they are illegible or missing.
- **Monthly:** Lubricate the grease fittings. We recommend using white lithium grease or similar.
- **Monthly:** Check the Power Unit's Hydraulic Fluid levels. Refill if low.

 **WARNING** When accessing the Power Unit inside the Console for maintenance, do **not** use the Back Panel as the point of entrance; the Power Unit is mounted to the Back Panel. If the Back Panel is removed, the weight of the Power Unit may cause it to fall over and risk product damage and/or personal injury to anyone nearby.

- **Every two months:** Check all Anchor Bolts to make sure they are tight. If not, tighten them.
- **Twice yearly:** Have an Electrician come out and check all of the electrical components and electrical connections.

 **WARNING** Do not operate your Lift if you find issues; instead, take the lift out of service, then contact your dealer, email support@bendpak.com, visit bendpak.com/support, or call **(800) 253-2363**, extension 196.

Troubleshooting

This section describes how to troubleshoot your Lift.

The Lift uses electrical and pneumatic energy; if your organization has Lockout/Tagout policies, implement them before performing any troubleshooting.

Note: If your Lift is not functioning correctly, you must take it out of service until it is fixed.

Important: All repair work *must* be done by qualified personnel.

Issue	Action to Take
Platforms move erratically or squeak when in use.	Move the Platforms up and down a few times, with a break between each; there could be residual air in the Hydraulic System.
Platforms do not go up or down.	Make sure the Power Unit is connected to an appropriate power source. Make sure none of the Hydraulic Hoses are pinched or leaking. Make sure there is sufficient Hydraulic Fluid in the reservoir on the Power Unit.
Hydraulic Fluid is old or dirty.	Replace the dirty fluid with clean, approved Hydraulic Fluids, such as Dexron III, Dexron VI, Mercon V, Mercon LV, Shell Tellus S4 / S3 / S2, or comparable.
Platforms do not rise from a zero net rise position.	Platforms cannot raise the weight of a Vehicle from a completely flat position; that is, the wheels are removed and the Lift is fully lowered. The Platforms need some space to get upward force started. Refer to Fully Lowered Vehicle with No Wheels below.
Platforms make odd noises when in use.	Lubricate hinge points using white lithium grease.
Platforms are slowly lowering on their own.	Make sure both Platforms are on Safety Locks (if not, Hydraulic Fluid could be leaking out, lowering the Platforms). Only leave the Lift either fully lowered or engaged on a Safety Lock.

If you continue to have problems with your Lift, contact your dealer, visit bendpak.com/support, email support@bendpak.com, or call **(800) 253-2363**, extension 196.

Fully Lowered Vehicle with No Wheels

The issue is that there is too much weight on the Platforms with no room to get upward force started. To fix this issue, you need to reduce the weight on the Platforms by at least half or raise the Vehicle off the Platforms some other way.

Methods that have fixed this issue include:

- Use floor jacks to raise the Vehicle up four inches or higher.
- Use a lifting device to raise the Vehicle up four inches or higher.

If you are still unable to raise your Vehicle, contact BendPak Technical Support for assistance.

Wiring Diagrams

These wiring diagrams (on the following page) use the United States color codes for the three power source wires in the pigtail that comes out of the electrical box on the Power Unit:

- **Black:** Live
- **White:** Live
- **Green:** Ground

If you are using the unit in a European country, the Black – White – Green colors correspond to:

- **Brown:** Live
- **Blue:** Neutral
- **Green/Yellow:** Ground

Information about color code conventions in other regions and countries is available online.

⚠ WARNING All electrical work, such as hard-wiring the unit or attaching a Plug to the Power Cord, **must be done by a licensed, certified Electrician** in accordance with all applicable local electrical codes. Damage caused by improper electrical installation may void your warranty.

5585020

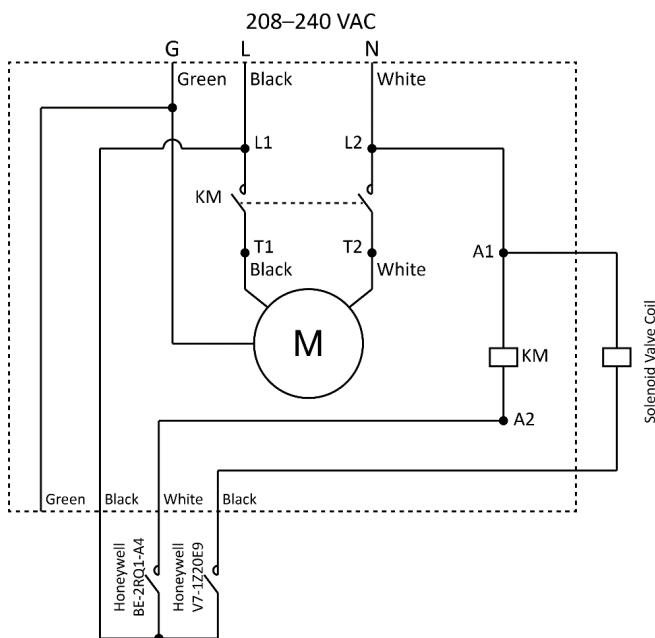

5585015

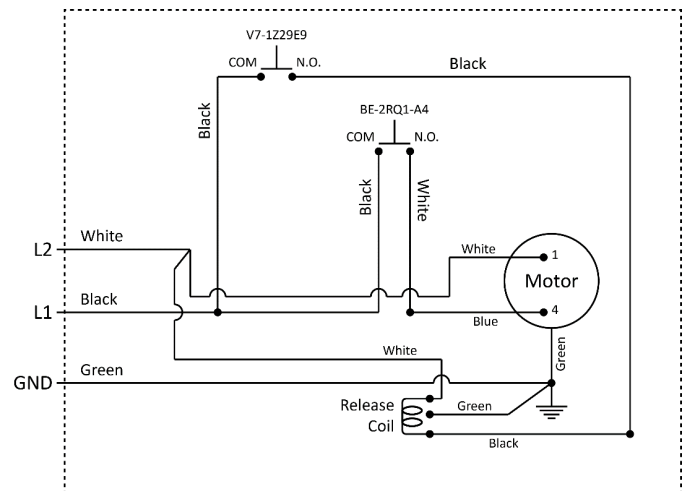

5585239

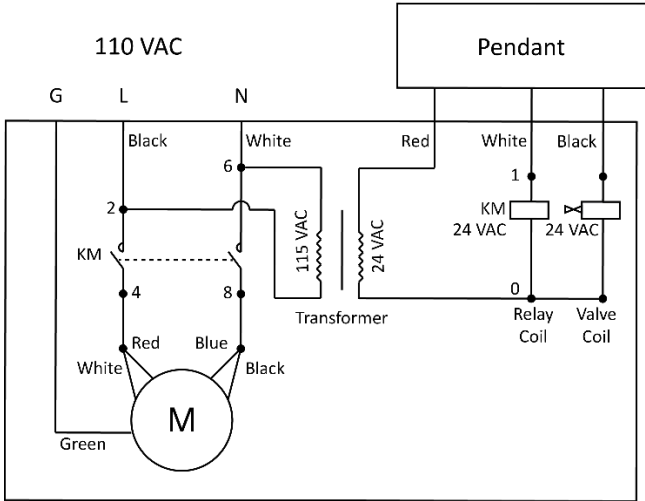

Wiring for 110 VAC

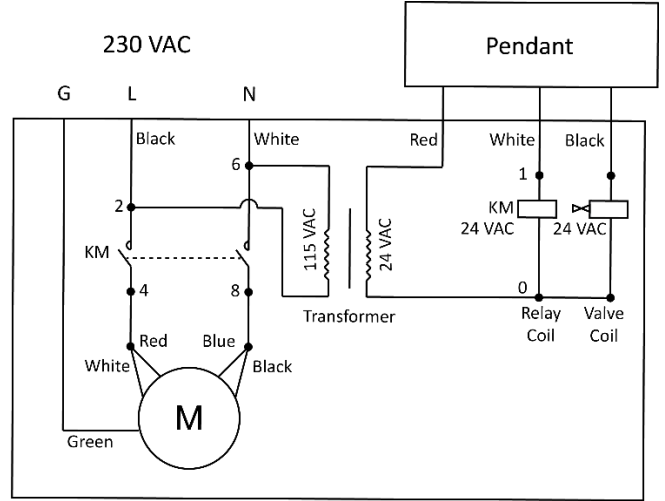

Wiring for 230 VAC

Labels

P9000 Series Product Label Positioning

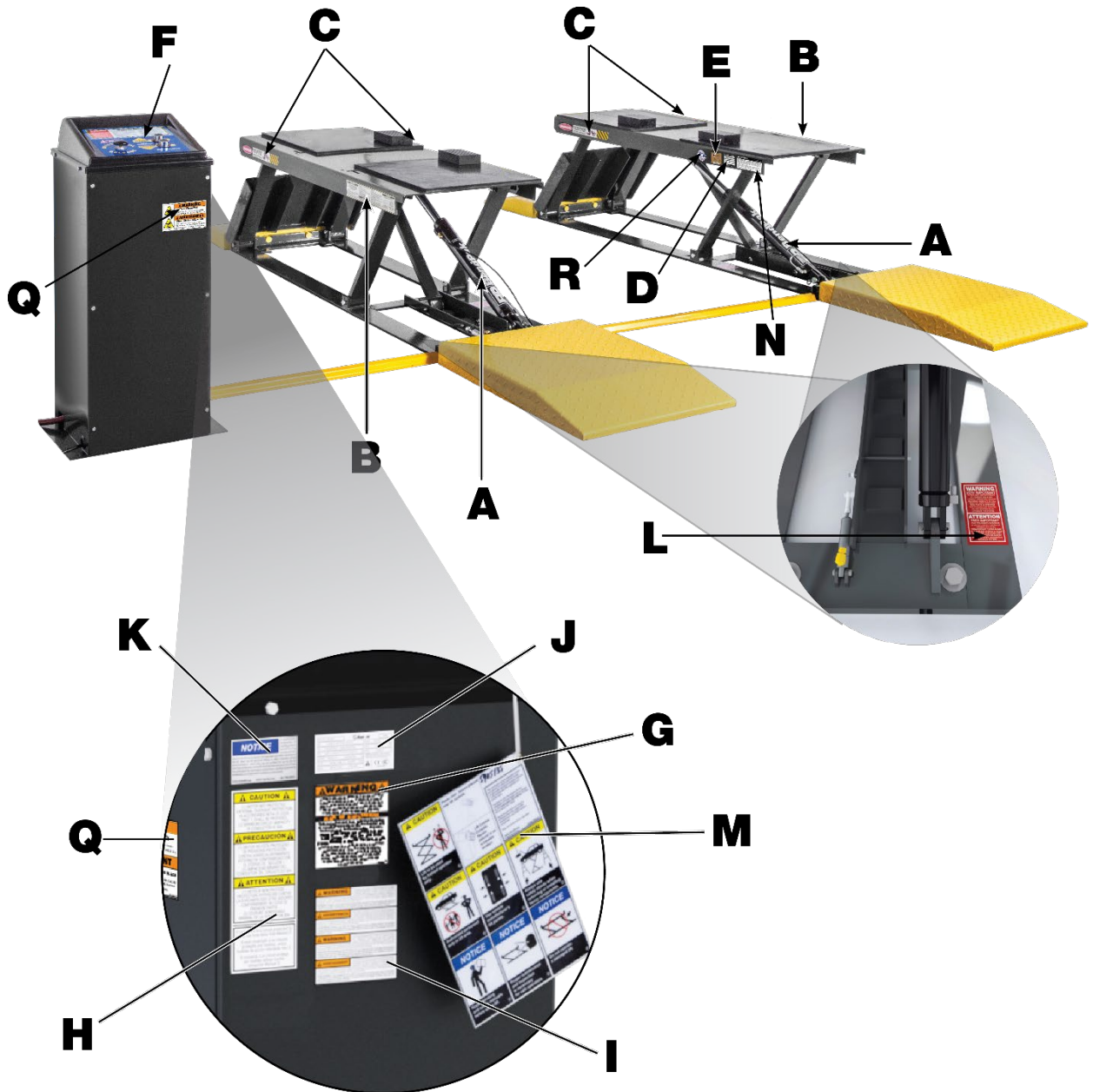

RIGHT SIDE OF CONSOLE

A

BendPak®
PROVIDING AUTOMOTIVE SERVICE SOLUTIONS
1645 Lemonwood Dr., Santa Paula, CA 93060 • TEL: 805-633-9970 • www.bendpak.com • ENGINEERED BY BENDPAK USA • MADE IN CHINA

B

WARNING
Read and understand all safety warnings and operation procedures before using lift. Keep hands and feet clear from moving parts.

OPERATION INSTRUCTIONS

TO RAISE LIFT:

- Check area of operation and make sure lift is in full lowered position.
- Make sure all safety chains are attached to the lift and that they are properly secured.
- Do not use lift unless the vehicle is properly secured to the lift.
- Do not use lift unless the vehicle is properly secured to the lift.
- Do not use lift unless the vehicle is properly secured to the lift.
- Do not use lift unless the vehicle is properly secured to the lift.
- Do not use lift unless the vehicle is properly secured to the lift.
- Do not use lift unless the vehicle is properly secured to the lift.
- Do not use lift unless the vehicle is properly secured to the lift.
- Do not use lift unless the vehicle is properly secured to the lift.

TO LOWER LIFT:

- Do not use lift unless lift is fully lowered.
- Do not use lift unless lift is fully lowered.
- Do not use lift unless lift is fully lowered.
- Do not use lift unless lift is fully lowered.
- Do not use lift unless lift is fully lowered.
- Do not use lift unless lift is fully lowered.
- Do not use lift unless lift is fully lowered.
- Do not use lift unless lift is fully lowered.
- Do not use lift unless lift is fully lowered.
- Do not use lift unless lift is fully lowered.

WARNING
DRIVE CAR COMPLETELY OVER LIFT
CONDUITE LA VÉHICULE COMPLÈTEMENT SUR L'ASCENSEUR

ATTENTION
Lisez et comprenez tous les avvertissements de sécurité et les procédures d'utilisation avant d'utiliser l'ascenseur. Gardez les mains et les pieds à l'écart des pièces mobiles.

ATTENTION
POUR SURÉLEVER L'ASCENSEUR

NEVER OVERLOAD LIFT
CHECK THE LIFT'S RATED CAPACITY.
NE JAMAIS SURÉLEVER L'ASCENSEUR
VÉRIFIER LA CAPACITÉ MAXIMALE DE CHARGE.

DO NOT OPERATE ON A SLIP LIFT
NE PAS OPERER SUR UN SOL GLISSANT.

POUR DESCENDRE L'ASCENSEUR:

- Vérifier l'état de la zone de travail et s'assurer que le véhicule est correctement positionné sur le pont de levage.
- Ne pas utiliser l'ascenseur à moins que le véhicule soit correctement sécurisé à l'ascenseur.
- Ne pas utiliser l'ascenseur à moins que le véhicule soit correctement sécurisé à l'ascenseur.
- Ne pas utiliser l'ascenseur à moins que le véhicule soit correctement sécurisé à l'ascenseur.
- Ne pas utiliser l'ascenseur à moins que le véhicule soit correctement sécurisé à l'ascenseur.
- Ne pas utiliser l'ascenseur à moins que le véhicule soit correctement sécurisé à l'ascenseur.
- Ne pas utiliser l'ascenseur à moins que le véhicule soit correctement sécurisé à l'ascenseur.
- Ne pas utiliser l'ascenseur à moins que le véhicule soit correctement sécurisé à l'ascenseur.
- Ne pas utiliser l'ascenseur à moins que le véhicule soit correctement sécurisé à l'ascenseur.

C

DANGER

KEEP HANDS AND FEET CLEAR AT ALL TIMES FROM MOVING MACHINERY
GARDEZ LES MAINS ET LES PIEDS À DISTANCE À TOUT MOMENT DES MACHINES EN MOUVEMENT

D

BP BendPak Santa Paula, CA USA
www.bendpak.com

MODEL NUMBER

DESCRIPTION

LIFT CAPACITY **DATE OF MFG.**

VOLTAGE **SERIAL NUMBER**

- 110-240V, 50-60 Hz, 1 Ph
- 208-240V, 50-60 Hz, 1 Ph
- 380-415V, 50-60 Hz, 3 Ph
- 208-140V, 50-60 Hz, 3 Ph

UPC

DANGER!
Disconnect Power Before Servicing
WARRANTY VOID IF DATA PLATE IS REMOVED

EATC
PN 5909021

F

WARNING
FAILURE TO READ, UNDERSTAND, AND FOLLOW INSTRUCTIONS AND WARNINGS MAY RESULT IN SERIOUS PERSONAL INJURY AND/OR PROPERTY DAMAGE.

✓ Never exceed rated capacity of lift.
✓ DO NOT operate lift if any component is found to be defective or worn.
✓ Never operate lift with any person or equipment below.
✓ Always secure load in centered and stable prior to operating controls.

✓ Always verify safety locks are engaged before working on or near vehicle.
✓ Never leave lift in an elevated position unless all safety locks are engaged.
✓ Do not permit electric motor to get wet! Motor damage caused by dampness is not covered under warranty.

OPERATING INSTRUCTIONS

TO RAISE LIFT

- Position vehicle's center of gravity over center of lifting platform.
- Set parking brake and use wheel chocks to hold vehicle in position.
- Before raising vehicle, be sure all personnel are clear of lift and surrounding area. Pay careful attention to overhead clearances.
- Raise lift to desired height by pressing RAISE button.
- Monitor visual contact with vehicle and surrounding area at all times while raising or lowering lift.
- Monitor visual contact with vehicle and surrounding area at all times while raising or lowering lift.
- After vehicle is raised to desired height, lower lift onto the nearest safety locks.
- STOP IMMEDIATELY if load shifts or becomes unstable.

TO LOWER LIFT

- Before lowering vehicle, be sure all personnel, tools and equipment are clear of lift and surrounding area.
- Raise lift by pressing RAISE button. Elevate lift at least two inches to allow adequate clearance for locks to clear.
- Press and HOLD SAFETY LOCK RELEASE button.
- Lower vehicle by pressing LOWER button until lift has descended completely.
- When lowering lift, MAKE SURE that all personnel and objects are kept clear of lift and surrounding area.
- ALWAYS keep a visual line of sight on lift AT ALL TIMES.
- ALWAYS make sure that ALL LOCKS are disengaged. If one of the locks inadvertently engages on descent, lift and/or vehicle may drop causing serious injury or death.

SAFETY FIRST

SAFETY LOCK RELEASE

RAISE LIFT OPERATION LOWER

BP BendPak
TEL: 805-633-9970 • www.bendpak.com
1645 Lemonwood Dr., Santa Paula, CA 93060
ENGINEERED BY BENDPAK USA • MADE IN CHINA
PN 5909022

E

CERTIFIED AUTOMOTIVE LIFT

ALI CERTIFIED
To the provisions of ANSI/ALI ALCVTY-2011 SAFETY REQUIREMENTS FOR CONSTRUCTION, TESTING AND VALIDATION

Automotive Lift Institute, Inc. | Cortland, NY 13045

MET LISTED
Conforms to ANSI/UL 201 SAFETY STANDARD FOR GARAGE EQUIPMENT

UL LISTED
MET US

MET Laboratories, Inc. | BALTIMORE, MD 21220

Certification Label Serial Number
AL00617000J

G

WARNING
Always allow a minimum 2-second delay between motor starts. Failure to comply may cause switch and/or motor burnout. This could cause serious damage to the equipment and/or personal property.

RISK OF EXPLOSION
This equipment has internal arcing or sparking parts which should not be exposed to flammable vapors. THIS EQUIPMENT SHOULD BE LOCATED AT LEAST 460 MM (18 INCHES) ABOVE THE FLOOR.

All wiring must be performed by a certified electrician only. It is the responsibility of the electrician to ensure that all field wiring systems comply with both NEC recommendations and all additional electrical codes.

ATTENTION
Prévoyez toujours un délai minimum de 2 secondes entre les démarrages du moteur. Le non-respect de cette consigne peut entraîner l'épuisement des commutateurs et/ou du moteur. Cela pourrait causer de graves dommages à l'équipement et/ou aux biens personnels.

RISQUE D'EXPLOSION
Cet équipement comporte des pièces internes produisant des arcs électriques ou des étincelles qui ne doivent pas être exposées à des vapeurs inflammables. CET EQUIPEMENT DOIT ÊTRE SITUÉ AU MOINS 460 MM (18 POUÇES) AU-DESSUS DU SOL.

Tout le câblage doit être effectué par un électricien certifié. Il incombe à l'électricien de s'assurer que tous les systèmes de câblage sur site sont conformes aux recommandations NEC et à tous les codes électriques supplémentaires.

H

⚠ CAUTION ⚠

- Motor not protected - external overheat protection in accordance with CE code, Part 1, shall be provided.
- Minimum circuit ampacity of conductor is 30A.

⚠ PRECAUCIÓN ⚠

- Motor no está protegido - se proveerá protección contra sobrecalentamiento externo de conformidad con el código CE, Sección 1.
- Ampacidad mínimo del conductor del circuito es 30A.

⚠ ATTENTION ⚠

- Moteur non protégé - une protection externe contre la surchauffe conforme au code CE, Partie 1, doit être fournie.
- L'ampacité minimale du circuit du conducteur est de 30A.

If connected to a circuit protected by fuses use time-delay fuse Marked D
Si está conectado a un circuito protegido por fusibles, utilice fusibles de acción retardada, tipo D
Si connecté à un circuit protégé par fusibles utilisez fusible temporisé Marqué D

REV. 1119 PN 5905478

I

⚠ WARNING ⚠

This power unit contains a hydraulic pump that is capable of developing pressure in excess of 5,000 psi (345 BAR). A pressure relief valve is used to set the pressure at the desired level. Tampering with, adjusting, modifying, or removing the relief valve is extremely dangerous and is not recommended. Only a trained hydraulics technician, using a calibrated hydraulic pressure gauge to assure the proper pressure setting is achieved, should make adjustments to the relief valve.

WARNING: Changes to the output pressure may render the power unit incompatible with pressure limitations of other components in the hydraulic circuit. This may cause catastrophic failure of those components, and could result in property damage, serious personal injury, or death.

⚠ ADVERTENCIA ⚠

Esta central hidráulica contiene una bomba capaz de desarrollar una presión en exceso de 5,000 psi (345 BAR). La presión está establecida por la válvula de descarga al nivel de presión deseada. Es extremadamente peligroso y no está recomendado, descomponerla, modificarla, ajustarla o removerla. Solo un técnico cualificado, utilizando un manómetro hidráulico calibrado para asegurar que la propia presión es alcanzada, podrá hacer modificaciones a la válvula de descarga.

ADVERTENCIA: Cambios a la salida de presión, podrían hacer la central hidráulica incompatible con las limitaciones de presión de otros componentes en el circuito hidráulico. Esos componentes podrían funcionar mal causando una catástrofe y podría resultar en daño a la propiedad, serio daño personal o muerte.

⚠ WARNING ⚠

Dieses Hydraulikaggregat beinhaltet eine Pumpe, welche einen Betriebsdruck bis zu 345 bar aufbauen kann. Ein integriertes Druckbegrenzungsventil begrenzt diesen Betriebsdruck. Missbrauch, verändern der Druckeinstellung, technische Veränderungen oder entfernen des Ventils, sind extrem gefährlich und daher nicht zu empfehlen. Nur qualifiziertes Personal mit Hydraulikerfahrung, sollte unter Verwendung eines kalibrierten Manometers den Druck dieses Sicherheitsventils einstellen.

WARNUNG: Eine Veränderung des Betriebsdruckes am Aggregat, kann zu Problemen bei anderen angeschlossenen Komponenten führen, welche nur über einen geringeren zulässigen Betriebsdruck verfügen. Dies kann zur vollständigen Zerstörung dieser Geräte führen und zusätzlich zu schweren Verletzungen oder sogar zu Lebensgefahr beim Bedienpersonal führen.

⚠ AVERTISSEMENT ⚠

Cet équipement utilise une pompe hydraulique capable de fournir une pression de 345 bar. Une soupape de sûreté est utilisée pour régler la pression à la valeur souhaitée. Alterations, réglages, modifications ou suppression de cette soupape de sûreté peuvent se révéler très dangereux et ne sont absolument pas recommandés. Uniquement un hydraulicien qualifié, utilisant un manomètre pour permettre l'affichage précis de la pression, pourra assurer les réglages de la soupape de sûreté.

AVERTISSEMENT: Tout changement de la valeur de la pression de sortie peut rendre incompatible l'utilisation de cet équipement avec les autres composants du circuit hydraulique. Ceux-ci peuvent être endommagés de manière définitive et peuvent causer des dégâts matériels, ainsi que des risques de blessures sérieuses ou la mort.

J

SKU NO:	Ranger	PRV:	TENV
HP:	I.D. NO:	VOLTS:	
Hz:	RPM:	PHASE:	
PH:	NOT THE PROPERLY PROTECTED	FR:	
TANK:	DRY OIL	WARNING: Failure to connect the motor leads to equipment grounding conductor by using the grounding cord, green wire, or green wire braid, may result in serious electric shock.	
TYPE:	MOTOR	CE	CCC
DATE:	CLASS:	CODE:	

BENDPAK RANGER www.rangerproducts.com
Ranger Products is a registered trademark of BendPak Inc.

ENGINEERED BY RANGER PRODUCTS USA

L

WARNING
VERY IMPORTANT

TO PROLONG LIFE EXPECTANCY OF CYLINDER SEALS AND PREVENT PREMATURE LEAKAGE AND WEAR, RAISE LIFT TO FULL HEIGHT AT LEAST ONCE A DAY. ALSO, THIS IS AN EFFECTIVE WAY TO BLEED ANY TRAPPED AIR AND MAINTAIN EQUAL LIFTING OF THE SYSTEM.

ATTENTION
TRÈS IMPORTANT

POUR PROLONGER L'ESPÉRANCE DE VIE DES JOINTS CYLINDRES ET PRÉVENIR LES FUITES PRÉMATURÉES ET PORTEZ, ÉLEVEZ LE PLEIN ÉLEVÉ HAUTEUR AU MOINS UNE FOIS PAR JOUR. AUSSI, C'EST UN EFFICACE FAÇON DE SAIGNER TOUT PIÉGÉ AIR ET MAINTIEN ÉGAL LEVAGE DU SYSTÈME.

PN 5905729

K

NOTICE

If attachments, accessories, or configuration modifying components used on this lift are located in the load path and affect operation of the lift, affect the lift electrical listing, or affect intended vehicle accommodation; and if they are not certified for use on this lift, then the certification of this lift shall become null and void. Contact the participant for information pertaining to certified attachments, accessories, or configuration modifying components.

www.autolift.org ©2011 by ALI, Inc. ALI / WLSIA01

M

<p>CAUTION</p> <p>Lift to be used by trained operator only.</p>	<p>Power Unit: Secure placard near lift controls.</p> <p>Lift Control Console: Secure placard in an accessible location.</p>	<p>5905135</p> <p>The messages and pictographs shown are generic in nature and are meant to generally represent hazards common to all automotive lifts regardless of specific style.</p> <p>Funding for the development and validation of these labels was provided by the Automotive Lift Institute, PO Box 85 Cortland, NY 13045.</p> <p>Replacement label sets may be obtained from the original lift manufacturer and ALI's member companies.</p> <p>They are protected by copyright.</p> <p>www.autolift.org © 2012 by ALI, Inc. ALIWL300caw</p>
<p>CAUTION</p> <p>Authorized personnel only in lift area.</p>	<p>CAUTION</p> <p>Use vehicle manufacturer's lift points.</p>	<p>CAUTION</p> <p>Always use safety stands when removing or installing heavy components.</p>
<p>NOTICE</p> <p>Read operating and safety manuals before using lift.</p>	<p>NOTICE</p> <p>Proper maintenance and inspection is necessary for safe operation.</p>	<p>NOTICE</p> <p>Do not operate a damaged lift.</p>

N

BendPak
PROVIDING AUTOMOTIVE SERVICE SOLUTIONS

SANTA PAULA, CA USA
WWW.BENDPAK.COM
PH 5905040

LIFT TYPE: SURFACE MOUNT GAP: MED/HVY DTY MFG. BPK SEE DATA PLATE FOR PRODUCT DETAILS
POWER: ELECTRIC/HYDRAULIC INSTALLATION - SEE OWNERS GUIDE OR CONTACT FACTORY

SAFETY INSTRUCTIONS: IF ATTACHMENTS, ACCESSORIES OR CONFIGURATION MODIFYING COMPONENTS THAT ARE LOCATED IN THE LOAD PATH, AFFECT OPERATION OF THE LIFT, AFFECT THE LIFT ELECTRICAL LISTING OR AFFECT INTENDED VEHICLE ACCOMMODATION ARE USED ON THIS LIFT AND, IF THEY ARE NOT CERTIFIED FOR USE ON THIS LIFT, THEN THE CERTIFICATION OF THIS LIFT SHALL BECOME NULL AND VOID. CONTACT THE PARTICIPANT FOR INFORMATION PERTAINING TO CERTIFIED ATTACHMENTS, ACCESSORIES OR CONFIGURATION MODIFYING COMPONENTS.

BENDPAK LIFTS ARE SUPPLIED WITH CONCRETE FASTENERS MEETING THE CRITERIA AS PRESCRIBED BY ASTM E489 - 96(2009). LIFT BUYERS ARE RESPONSIBLE FOR ANY SPECIAL REGIONAL STRUCTURAL AND/OR SEISMIC ANCHORING REQUIREMENTS SPECIFIED BY ANY OTHER AGENCIES AND/OR CODES SUCH AS THE UNIFORM BUILDING CODE (UBC) AND/OR INTERNATIONAL BUILDING CODE (IBC).

THE MANUFACTURE, USE, SALE OR IMPORT OF THIS PRODUCT MAY BE SUBJECT TO ONE OR MORE UNITED STATES PATENTS, OR PENDING APPLICATIONS, OWNED BY BENDPAK, INC.
DO NOT REMOVE ENGINEERED BY BENDPAK INC. USA MADE IN CHINA

Q

WARNING

SLIPPERY WHEN WET OR ICY

Use caution when driving onto wet or icy drive-up ramps and platforms. **DO NOT** walk on lift surfaces that are wet or icy.

AVERTISSEMENT

GLISSANT LORSQU'IL EST MOUILLÉ OU GLACÉ

Soyez prudent lorsque vous conduisez sur des rampes d'accès mouillées ou verglacées et les plateformes. **NE PAS** marcher sur des surfaces de levage humides ou glacées.

PH 5905138

R



O

<p>WARNING</p> <p>Maximum load capacity for the Lift Arms is 2,250 pounds (1,021 kg) each or 9,000 pounds (4,082 kg) per set of four when the Lift Arms are extended less than four inches past the edge of the Platform. Rated capacity is reduced past four inches; see manual for details. Overloading the Lift Arms can damage equipment and/or result in serious bodily injury or death and voids the product warranty.</p> <p>PH 5905148</p>	<p>ATTENTION</p> <p>La capacité de charge maximale des bras de levage est de 2250 livres (1021 kg) chacun ou de 9000 livres (4082 kg) par jeu de quatre lorsque les bras de levage sont étendus à moins de quatre pouces au-delà du bord de la plate-forme. La capacité nominale est réduite au-delà de quatre pouces; voir le manuel pour plus de détails. Une surcharge des bras de levage peut endommager l'équipement et / ou entraîner des blessures corporelles graves ou la mort et annule la garantie du produit.</p>
--	---

For optional Arm Kit

P

<p>WARNING</p> <p>NEVER rotate inside edges of Lift Arms beyond corners of lift platforms as shown. Extending pads more than 4 inches past edge of platform reduces rated capacity of arms. See manual for details.</p> <p>NEVER attempt to lift a vehicle using Lift Arms unless the Safety Stop Bushings are securely in place. DO NOT use any vehicle Lift Arm if any Safety Stop Bushing is missing.</p>		<p>ATTENTION</p> <p>NE JAMAIS faire tourner les bords intérieurs des bras de levage au-delà des coins des plates-formes de levage, comme illustré. L'extension des coussinets de plus de 101 mm au-delà du bord de la plate-forme réduit la capacité nominale des bras. Voir le manuel pour plus de détails.</p> <p>N'essayez JAMAIS de soulever un véhicule à l'aide des bras de levage à moins que les bagues d'arrêt de sécurité ne soient bien en place. NE PAS utiliser de bras de levage de véhicule s'il manque une bague d'arrêt de sécurité.</p> <p>PH 5918002</p>
--	--	--

Parts Diagrams

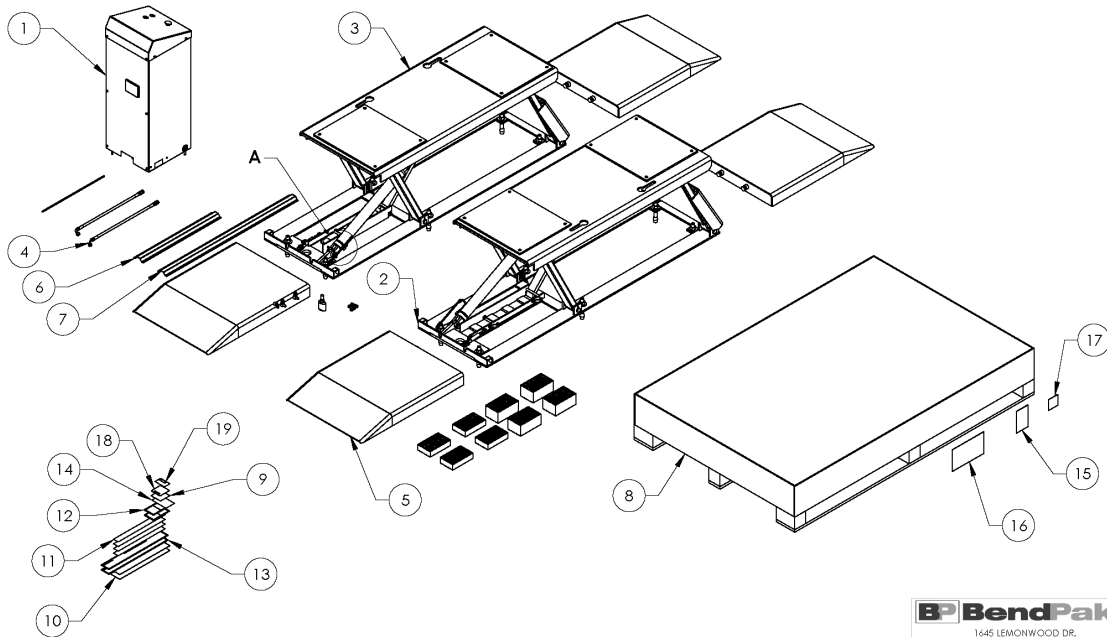

BendPak
 1645 LEMONWOOD DR.
 SANTA PAULA, CA 93060

TITLE:
P9000LT PRODUCTION LIFT

SIZE	DWG. NO.	REV
A	5260196	P

SCALE: 1:20 SHEET 2 OF 5

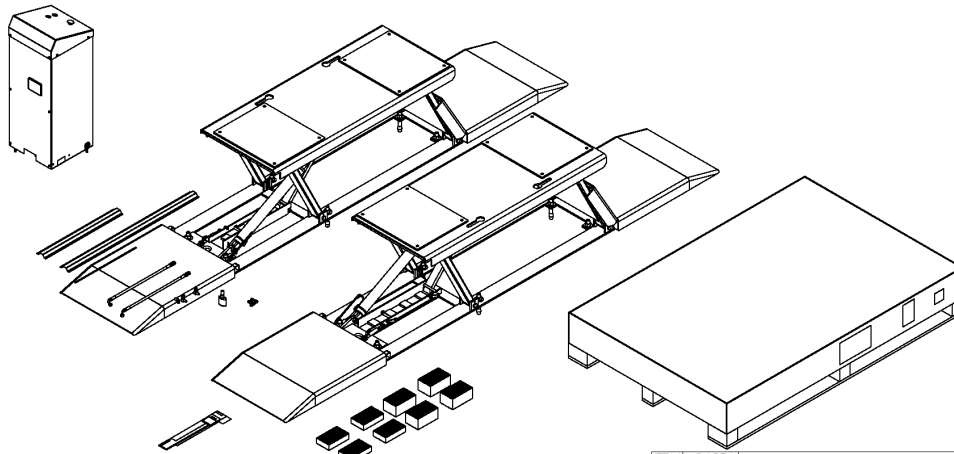

ITEM NO	PART NUMBER	DESCRIPTION	QTY	REV
1	5215280	SHORT POWER UNIT CONSOLE ASSEMBLY	1	D
2	5215498	P9000LT RH RAMP ASSEMBLY	1	H
3	5215500	P9000LT LH RAMP ASSEMBLY	1	H
4	5250034	P9000LT PARTS BOX	1	N
5	5215916	P9000LT APPROACH RAMP ASSEMBLY	4	A
6	5201544	P9000 HYDRAULIC HOSE COVER SHORT	1	A
7	5201325	HYDRAULIC HOSE COVER	1	A
8	5940057	P9000LT WOODEN CRATE ASSEMBLY	1	A
9	5905951	SERIAL TAG B	1	--
10	5905204	BENDPAK LABEL	2	--
11	5905350	WARNING PINCH POINTS SMALL ENGLISH-FRENCH	4	--
12	5905176	WARNING TO PROLONG LIFE ENG-FRE	2	--
13	5930638	P9000 OPERATION INSTRUCTIONS DECAL ENG-FRE	2	--
14	5905940	PRODUCT DATA LABEL	1	--
15	5905465	MANUFACTURER LABEL	1	--
16	5905006	P9000LT PACKAGING LABEL	1	--
17	5905285	SERIAL TAG EXTERIOR PEEL OFF INVENTORY LABEL	1	--
18	5905653	LABEL: ALL-ALC1V-2017 GOLD LABEL, US: MET LABS	1	--
19	5905377	NOTICE LABEL: ALL/MSIA01	1	--

DO NOT SCALE DRAWING

DRAWN	TS	01/09/2018
CHECKED	OR	09/04/2020

DIMENSIONS ARE IN MM

THIRD ANGLE PROJECTION

BendPak
 1645 LEMONWOOD DR.
 SANTA PAULA, CA 93060

TITLE:
P9000LT PRODUCTION LIFT

SIZE	DWG. NO.	REV
A	5260196	P

SCALE: 1:26 SHEET 1 OF 5

PROPRIETARY AND CONFIDENTIAL
 THE INFORMATION CONTAINED IN THIS DRAWING IS THE SOLE PROPERTY OF BENDPAK INC. (2017)
 NO PART OF THIS DRAWING IS TO BE REPRODUCED OR TRANSMITTED IN ANY FORM OR BY ANY MEANS WITHOUT THE WRITTEN PERMISSION OF BENDPAK INC. (2017)

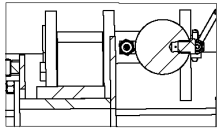
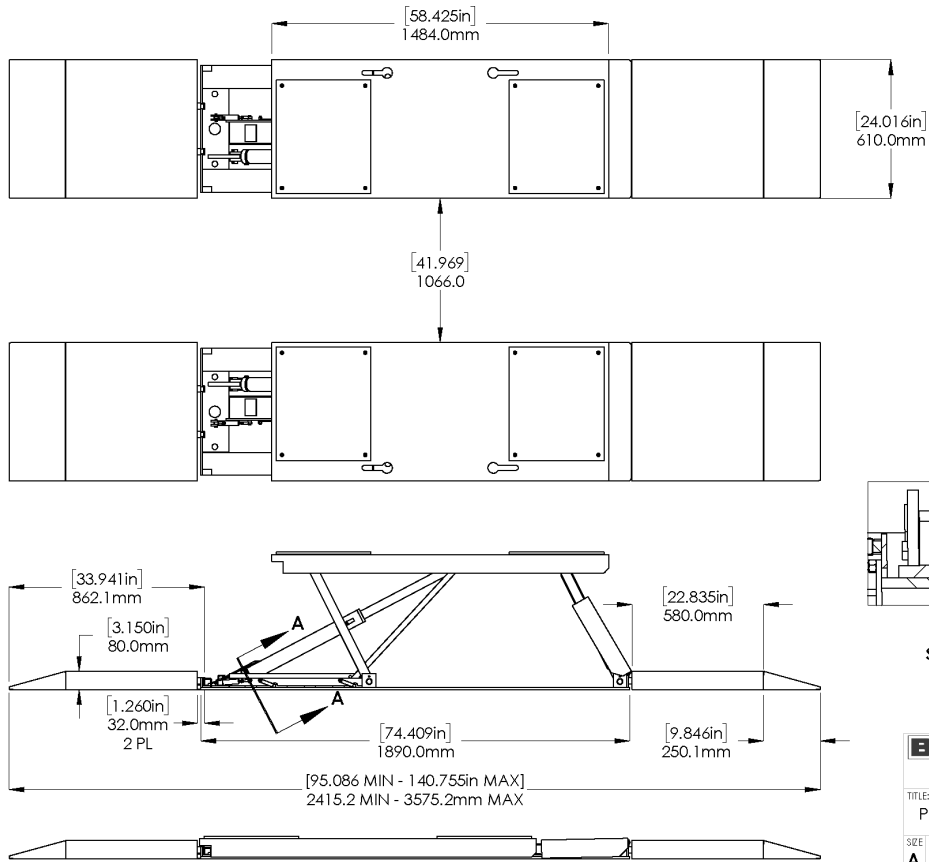

SECTION A-A
SCALE 1 : 5

BendPak.
1645 LEMONWOOD DR.
SANTA PAULA, CA 93060

TITLE:
P9000LT PRODUCTION LIFT

SIZE	DWG. NO.	REV
A	5260196	P

SCALE: 1:20 SHEET 4 OF 5

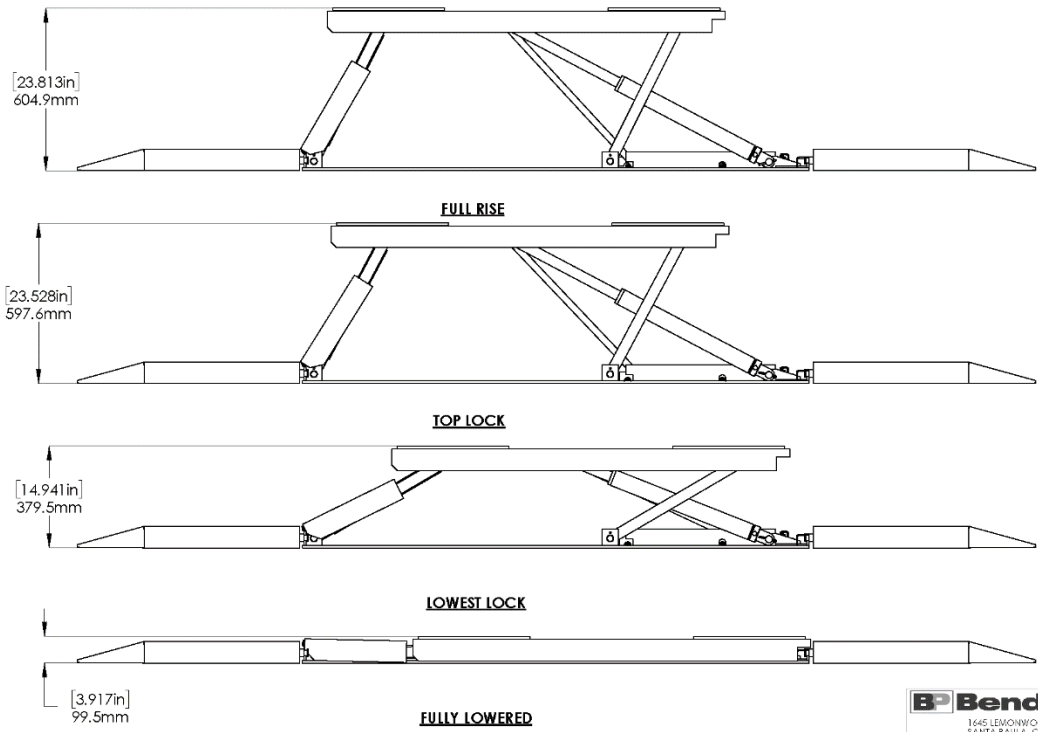

BendPak.
1645 LEMONWOOD DR.
SANTA PAULA, CA 93060

TITLE:
P9000LT PRODUCTION LIFT

SEE	DWG. NO.	REV
A	5260196	P

SCALE: 1:16 SHEET 3 OF 5

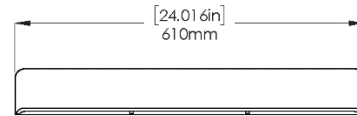
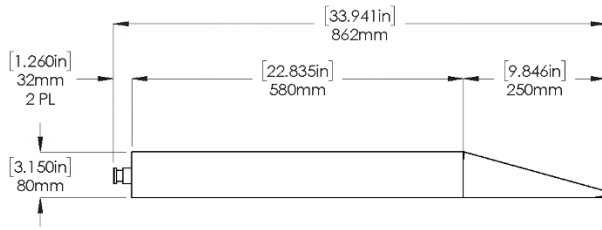

BendPak
 1445 LEMONWOOD DR.
 SANTA PAULA, CA 92060

TITLE: **P9000LT APPROACH RAMP ASSEMBLY**

SEE DWG. NO. **5215916** REV **A**

SCALE: 1:8 SHEET 2 OF 2

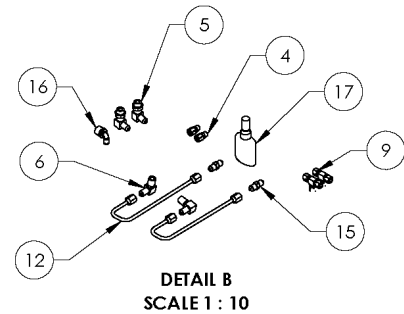
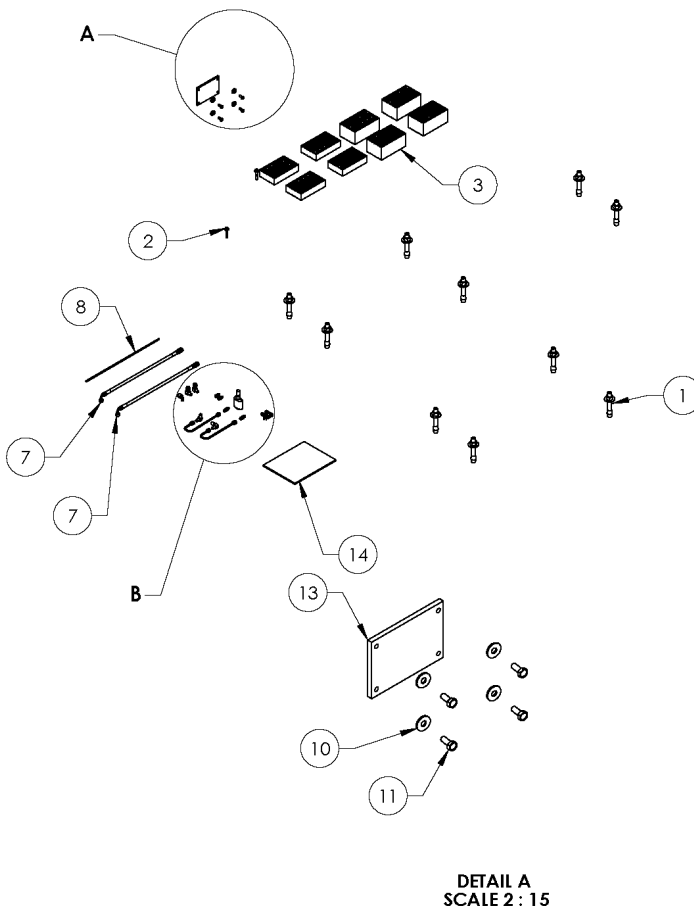

ITEM NO	PART NUMBER	DESCRIPTION	QTY	REV
1	5530456	AB 3/4" x 4 - 3/4"	12	--
2	5530326	AB Ø3/8" x 2-1/4"	2	--
3	5210232	LOW RISE SCISSOR LIFT RUBBER PAD KIT, SET OF 8	1	A
4	5550001	FTG NPL -04 COMP x-02 NPT	2	--
5	5550008	FTG ELB -04 JIC -06L ORB	2	--
6	5550086	FTG ELB -04 NPT x -04 JIC	2	--
7	5570040	P9000/SP-7XL HYDRAULIC HOSE ASSY Ø6.35 x 4270mm SB	2	D
8	5570795	1/4" POLY-FLO TUBING	5182mm	--
9	5550395	FTG TEE -04 COMP x-04 COMP x-04 COMP	2	--
10	5545340	WASHER M8 x24 FLAT	4	--
11	5530304	HHB M8 x 1.25 x 20	4	--
12	5215466	P9000 HYDRAULIC LINE ASSEMBLY	2	C
13	5715003	POWER UNIT VIBRATION DAMPENER	1	B
14	5900022	P9000LT INSTALLATION AND OPERATION MANUAL	1	--
15	5550095	FTG NPL -04 JIC x -04 JIC	2	--
16	5550004	FTG ELB 1/4 TUBE INS 3/8 NPT	1	--
17	5580012	LIQUID PTFE THREAD SEALANT 50ml	1	--

DO NOT SCALE DRAWING

DRAWN: JM 08/05/2015
 CHECKED: OR 9/10/2020

THIRD ANGLE PROJECTION

BendPak
 1445 LEMONWOOD DR.
 SANTA PAULA, CA 92060

TITLE: **P9000LT PARTS BOX**

SEE DWG. NO. **5250034** REV **N**

SCALE: 1:25 SHEET 1 OF 1

PROPRIETARY AND CONFIDENTIAL
 THE INFORMATION CONTAINED IN THIS DRAWING IS THE SOLE PROPERTY OF BENDPAK INC. ANY REPRODUCTION IN PART OR AS A WHOLE WITHOUT THE WRITTEN PERMISSION OF BENDPAK INC. IS PROHIBITED.

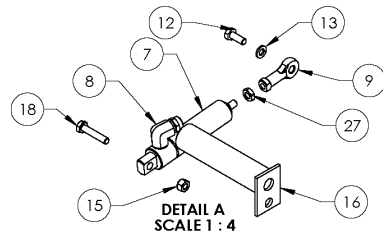
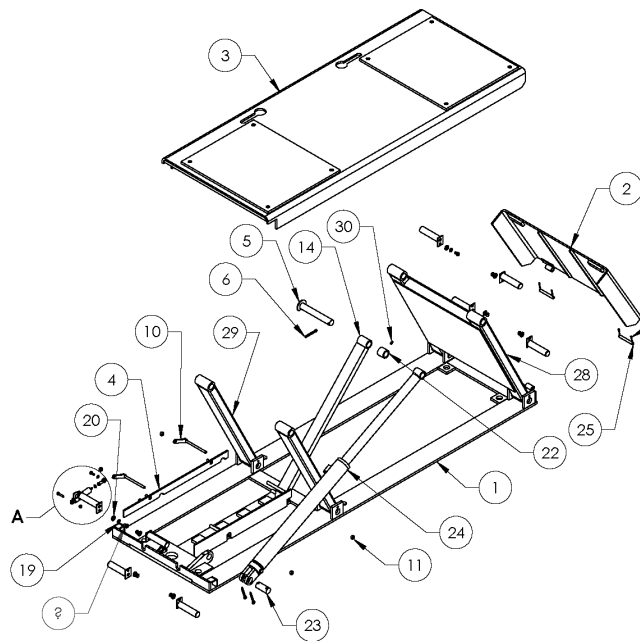

ITEM NO.	PART NUMBER	DESCRIPTION	QTY	REV
1	5601219	P9000LT SERIES L.H. BASE WELDMENT	1	A
2	5601222	P-9000LT HINGED RAMP WELDMENT	1	B
3	5215443	P9000LT R.H. TOP DECK ASSEMBLY	1	B
4	5601051	P9000 SERIES SAFETY LOCKOUT BAR WELDMENT, LH	1	C
5	5600969	P-9000/P-9000F UPPER HINGE PIN WELDMENT	1	A
6	5502400	Ø6 x 30mm COILER PIN	3	--
7	5502195	AIR CYLINDER, Ø19mm x 25 STROKE	1	--
8	5530087	FIG ELB-04 COMP x-02 NPT	1	--
9	5503625	FEMALE ROD END M6 x 33mm	1	--
10	5601124	P-9000 SERIES FORWARD PIVOT ARM WELDMENT	2	A
11	5535001	NUT M6 x 1.25 NI	4	--
12	5530019	HBB M6 x 1 x 15 SL	1	--
13	5545026	WASHER M6 x Ø12 SL	1	--
14	5600887	P-9000/P-9000F L.H. SAFETY BAR WELDMENT	1	B
15	5535357	NUT M6 x 1.0 NI	1	--
16	5601221	P9000 LT SERIES RAMP HINGE ARM PIVOT PIN WELDMENT	4	A
17	5601244	P9000 LT SERIES BASE HINGE ARM PIVOT PIN WELDMENT	4	A
18	5530047	HBB M6 x 1 x 30mm	8	--
19	5545202	WASHER M8 x Ø15.5 SL	8	--
20	5545341	WASHER M10 x Ø20 FLAT	8	--
21	5530025	HBB M8 x 1.25 x 12	8	--
22	5545035	P-9000/P-9000F SAFETY BAR SPACER	1	A
23	5502030	P-9000/P-9000F CLEVIS PIN	1	B
24	5502030	CYLINDER ASSEMBLY Ø2.0 x 17.75	1	F
25	5545425	P9000 HINGED RAMP PIN	2	A
26	5503006	COILER PIN Ø5.2 x 20mm	2	A
27	5535230	NUT 1/4-28 IN	1	--
28	5620613	P9000LT SERIES ASYMMETRIC HINGE DOUBLE ARM WELDMENT	1	A
29	5620612	P9000LT SERIES ASYMMETRIC HINGE ARM WELDMENT	2	A
30	5550025	FIG GRS M6 x 1.0	1	--

DO NOT SCALE DRAWING

NAME DATE
DRAWN TS 01/09/2018
CHECKED OR 4/29/2020

DIMENSIONS ARE IN MM

THIRD ANGLE PROJECTION

PROPRIETARY AND CONFIDENTIAL
THE INFORMATION CONTAINED IN THIS DRAWING IS THE SOLE PROPERTY OF BENDPAK, INC. ANY REPRODUCTION IN PART OR AS A WHOLE WITHOUT THE WRITTEN PERMISSION OF BENDPAK, INC. IS PROHIBITED.

SCALE: 1:18 SHEET 1 OF 1

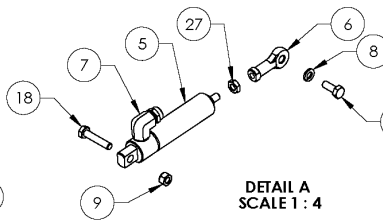
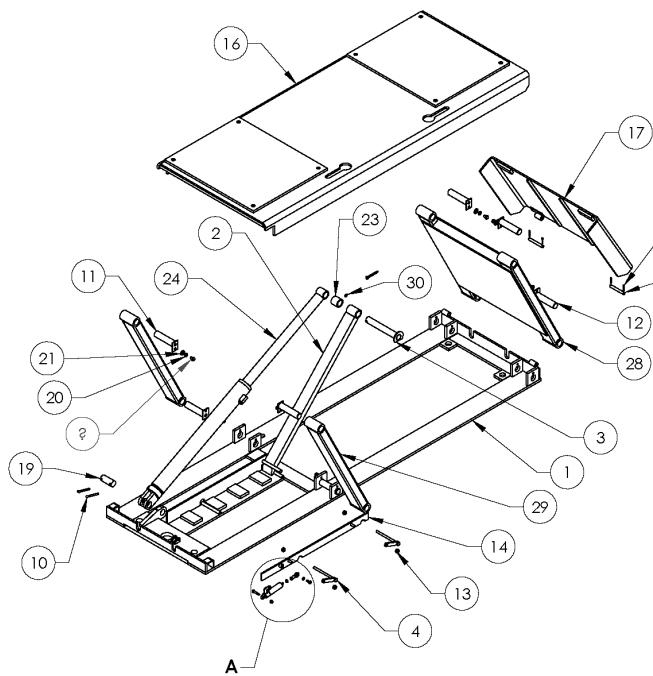

ITEM NO.	PART NUMBER	DESCRIPTION	QTY	REV
1	5601220	P9000LT SERIES R.H. BASE WELDMENT	1	A
2	5600886	P-9000/P-9000F R.H. SAFETY BAR WELDMENT	1	B
3	5600969	P-9000/P-9000F UPPER HINGE PIN WELDMENT	1	A
4	5601194	P-9000 SERIES FORWARD PIVOT ARM WELDMENT	2	A
5	5502195	AIR CYLINDER, Ø19mm x 25 STROKE	1	--
6	5503625	FEMALE ROD END M6 x 33mm	1	--
7	5530087	FIG ELB-04 COMP x-02 NPT	1	--
8	5545026	WASHER M6 x Ø12 SL	1	--
9	5535357	NUT M6 x 1.0 NI	1	--
10	5503400	Ø6 x 30mm COILER PIN	3	--
11	5601221	P9000 LT SERIES RAMP HINGE ARM PIVOT PIN WELDMENT	4	A
12	5601244	P9000 LT SERIES BASE HINGE ARM PIVOT PIN WELDMENT	4	A
13	5535001	NUT M6 x 1.25 NI	4	--
14	5601052	P9000 SERIES SAFETY LOCKOUT BAR WELDMENT, RH	1	C
15	5530019	HBB M6 x 1 x 16	1	--
16	5215499	P9000LT R.H. TOP DECK ASSEMBLY	1	B
17	5601222	P-9000LT HINGED RAMP WELDMENT	1	B
18	5530047	HBB M6 x 1 x 30mm	8	--
19	5545202	WASHER M8 x Ø15.5 SL	8	--
20	5545341	WASHER M10 x Ø20 FLAT	8	--
21	5530025	HBB M8 x 1.25 x 12	8	--
22	5545035	P-9000/P-9000F SAFETY BAR SPACER	1	A
23	5502030	P-9000/P-9000F CLEVIS PIN	1	B
24	5502030	CYLINDER ASSEMBLY Ø2.0 x 17.75	1	F
25	5545425	P9000 HINGED RAMP PIN	2	A
26	5503006	COILER PIN Ø5.2 x 20mm	2	A
27	5535230	NUT 1/4-28 IN	1	--
28	5620613	P9000LT SERIES ASYMMETRIC HINGE DOUBLE ARM WELDMENT	1	A
29	5620612	P9000LT SERIES ASYMMETRIC HINGE ARM WELDMENT	2	A
30	5550025	FIG GRS M6 x 1.0	1	--

DO NOT SCALE DRAWING

NAME DATE
DRAWN TS 01/09/2018
CHECKED OR 4/29/2020

DIMENSIONS ARE IN MM

THIRD ANGLE PROJECTION

PROPRIETARY AND CONFIDENTIAL
THE INFORMATION CONTAINED IN THIS DRAWING IS THE SOLE PROPERTY OF BENDPAK, INC. ANY REPRODUCTION IN PART OR AS A WHOLE WITHOUT THE WRITTEN PERMISSION OF BENDPAK, INC. IS PROHIBITED.

SCALE: 1:18 SHEET 1 OF 1

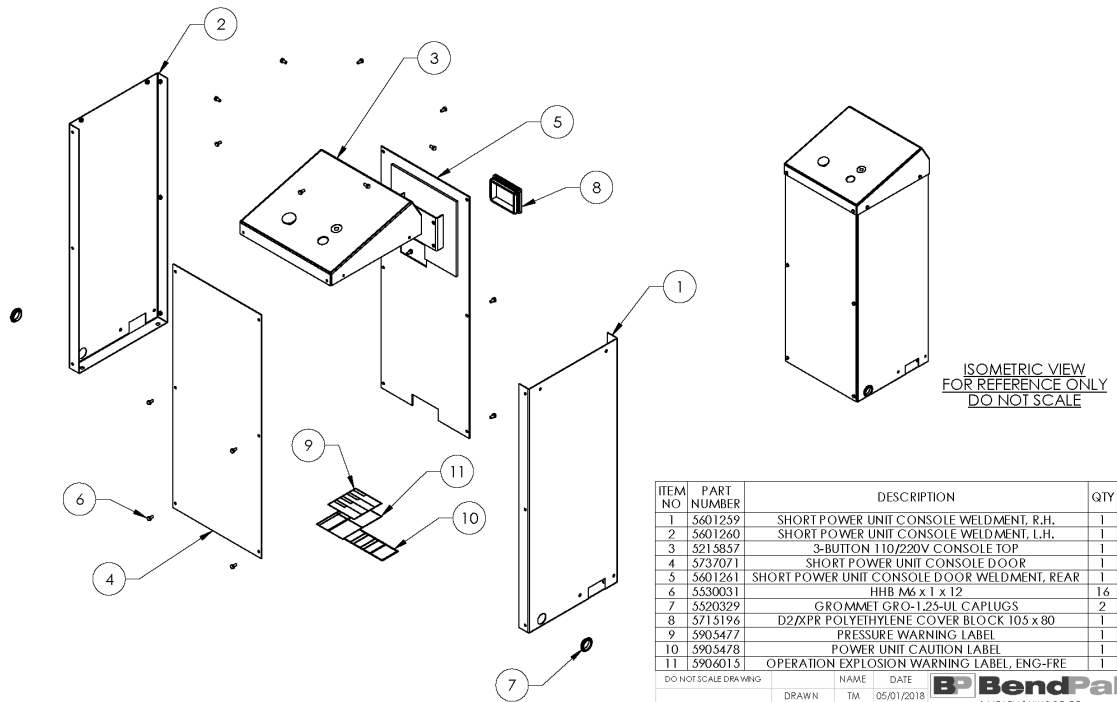

ITEM NO	PART NUMBER	DESCRIPTION	QTY	REV
1	5601259	SHORT POWER UNIT CONSOLE WELDMENT, R.H.	1	A
2	5601260	SHORT POWER UNIT CONSOLE WELDMENT, L.H.	1	A
3	5215857	3-BUTTON 110/220V CONSOLE TOP	1	B
4	5737071	SHORT POWER UNIT CONSOLE DOOR	1	A
5	5601261	SHORT POWER UNIT CONSOLE DOOR WELDMENT, REAR	1	A
6	5530031	HHB M6 x 1 x 12	16	--
7	5520329	GROMMET GRO-1.25-UL CAPPLUGS	2	--
8	5715196	D2/XPR POLYETHYLENE COVER BLOCK 105 x 80	1	D
9	5905477	PRESSURE WARNING LABEL	1	--
10	5905478	POWER UNIT CAUTION LABEL	1	--
11	5906015	OPERATION EXPLOSION WARNING LABEL, ENG-FRE	1	--

DO NOT SCALE DRAWING

NAME	DATE	BendPak 1645 LEMONWOOD DR. SANTA PAULA, CA 93060
DRAWN TM	05/01/2018	
CHECKED OR	4/14/2020	

DIMENSIONS ARE IN MM

THIRD ANGLE PROJECTION

TITLE: SHORT POWER UNIT CONSOLE ASSEMBLY

SIZE DWG. NO. REV

A 5215780 D

SCALE: 1:12 SHEET 1 OF 1

PROPRIETARY AND CONFIDENTIAL
THE INFORMATION CONTAINED IN THIS DRAWING IS THE SOLE PROPERTY OF BENDPAK INC. ANY REPRODUCTION IN PART OR AS A WHOLE WITHOUT THE WRITTEN PERMISSION OF BENDPAK INC. IS PROHIBITED.

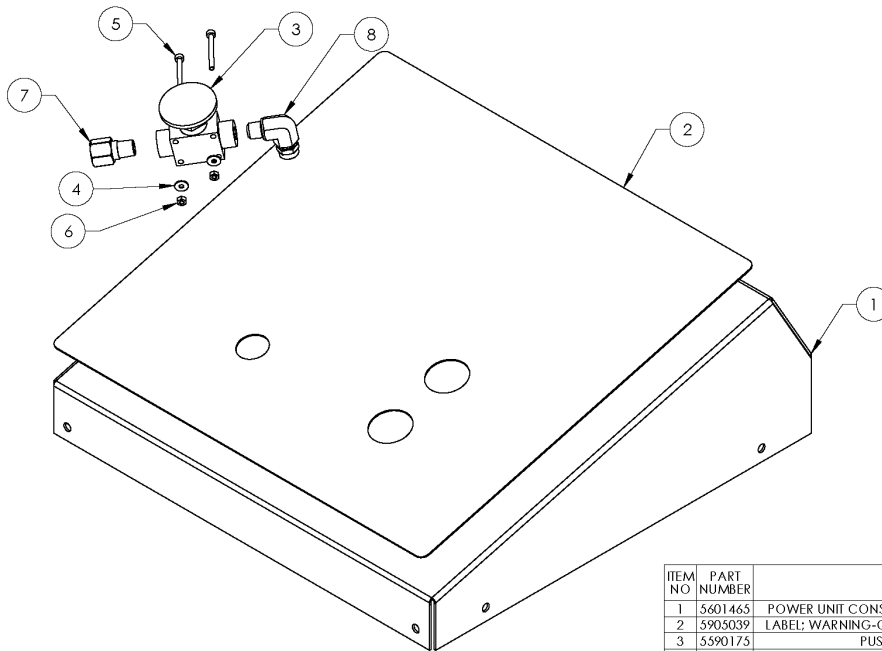

ITEM NO	PART NUMBER	DESCRIPTION	QTY	REV
1	5601465	POWER UNIT CONSOLE COVER WELDMENT (3 BUTTON)	1	A
2	5905039	LABEL: WARNING-OPERATING INSTRUCTIONS CONSOLE	1	--
3	5590175	PUSH BUTTON AIR VALVE	1	--
4	5545024	WASHER M3 x 9mm	2	--
5	5530043	SHCS M3 x 0.5 x 30	2	--
6	5535020	NUT M3 x 0.5 NL	2	--
7	5550486	FIG NPL -02 NPT x -04 F NPT	1	--
8	5550087	FIG ELB -04 COMP x -02 NPT	1	--

DO NOT SCALE DRAWING

NAME	DATE	BendPak 1645 LEMONWOOD DR. SANTA PAULA, CA 93060
DRAWN TM	05/24/2019	
CHECKED OR	4/14/2020	

DIMENSIONS ARE IN MM

THIRD ANGLE PROJECTION

TITLE: 3-BUTTON 110/220V CONSOLE TOP

SIZE DWG. NO. REV

A 5215857 B

SCALE: 1:3 SHEET 1 OF 1

PROPRIETARY AND CONFIDENTIAL
THE INFORMATION CONTAINED IN THIS DRAWING IS THE SOLE PROPERTY OF BENDPAK INC. ANY REPRODUCTION IN PART OR AS A WHOLE WITHOUT THE WRITTEN PERMISSION OF BENDPAK INC. IS PROHIBITED.

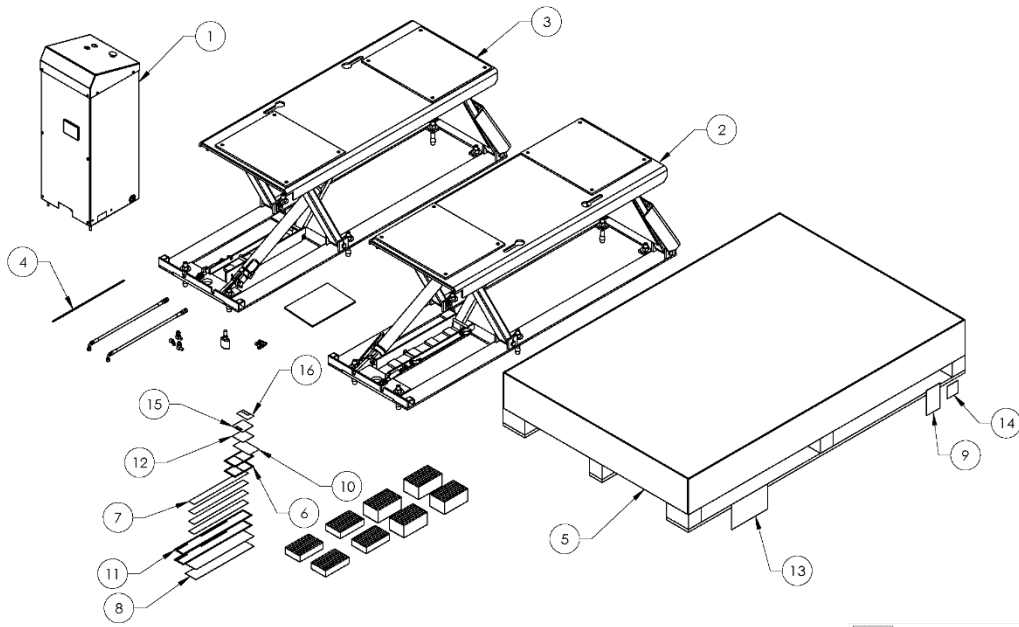

BP BendPak.
 1645 LEMONWOOD DR.
 SANTA PAULA, GA 30090

TITLE:
P9000LTF PRODUCTION LIFT

SEE DWG. NO.	REV
A 5260197	P

SCALE: 1:20 SHEET 2 OF 5

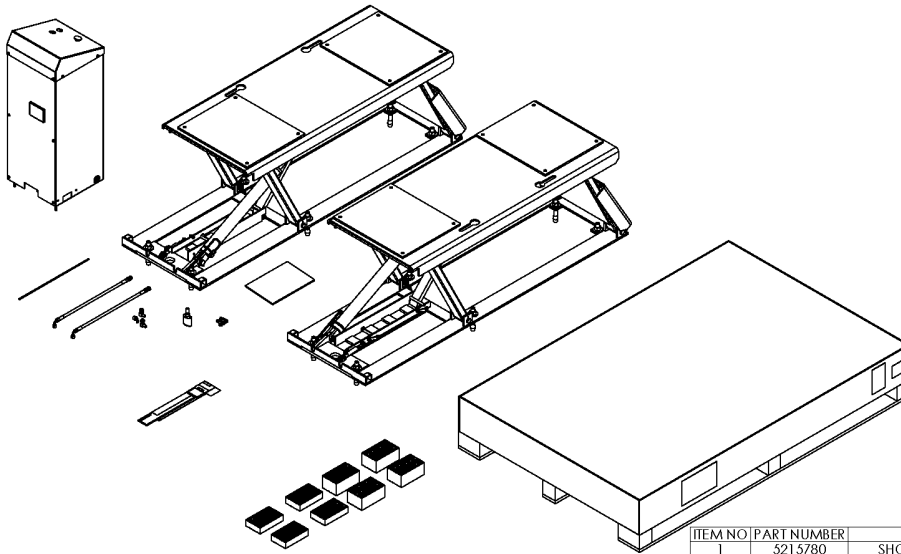

ITEM NO	PART NUMBER	DESCRIPTION	QTY	REV
1	521 5780	SHORT POWER UNIT CONSOLE ASSEMBLY	1	D
2	521 5498	P9000 LT SERIES R.H. RAMP ASSEMBLY	1	H
3	521 5500	P9000LT L.H. RAMP ASSEMBLY	1	H
4	5250034	P9000LT PARTS BOX	1	N
5	5940057	P9000LT WOODEN CRATE ASSEMBLY	1	A
6	5905376	WARNING TO PROLONG LIFE, ENG-FRE	2	--
7	5905350	WARNING- PINCH POINTS SMALL, ENGLISH-FRENCH	4	--
8	5905204	BENDPAK LABEL	2	--
9	5905465	MANUFACTURER LABEL	1	--
10	5905940	PRODUCT DATA LABEL	1	--
11	5930638	P9000 OPERATION INSTRUCTIONS DECAL, ENG-FRE	2	--
12	5905951	SERIAL TAG B	1	--
13	5905037	P9000LTF PACKAGING LABEL	1	--
14	5905285	SERIALTAG EXTERIOR PEEL OFF INVENTORY LABEL	1	--
15	5905653	LABEL: ALF-ALCTV-2017 GOLD LABEL, US: MET LABS	1	--
16	5905377	NOTICE LABEL, ALF/WLSIADI	1	--

DO NOT SCALE DRAWING

NAME	DATE
JM	01/10/2018
CHECKED OR	9/10/2020

DIMENSIONS ARE IN MM

THIRD ANGLE PROJECTION

BP BendPak.
 1645 LEMONWOOD DR.
 SANTA PAULA, GA 30090

TITLE:
P9000LTF PRODUCTION LIFT

SEE DWG. NO.	REV
A 5260197	P

SCALE: 1:25 SHEET 1 OF 5

PROPRIETARY AND CONFIDENTIAL
 THE INFORMATION CONTAINED IN THIS DRAWING IS THE SOLE PROPERTY OF BENDPAK, INC. ANY REPRODUCTION IN PART OR AS A WHOLE WITHOUT THE WRITTEN PERMISSION OF BENDPAK, INC. IS PROHIBITED.

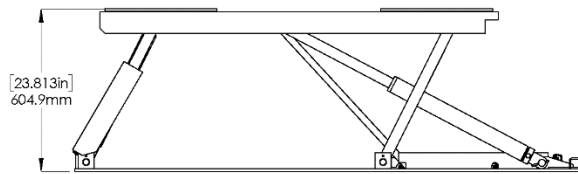

FULL RISE

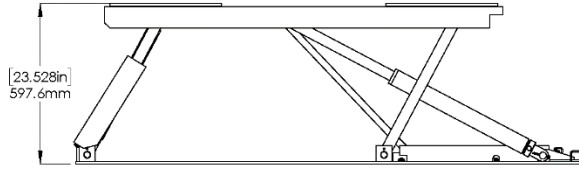

TOP LOCK

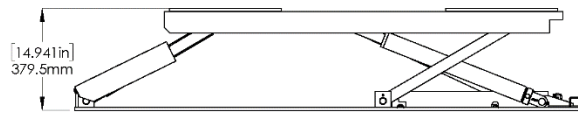

LOWEST LOCK

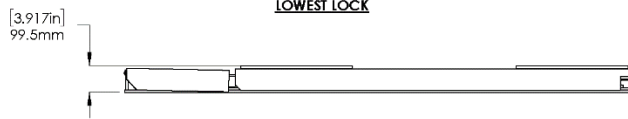

FULLY LOWERED

BP BendPak.	
1445 LEMONWOOD DR. SANTA PAULA, CA 93060	
TITLE: P9000LTF PRODUCTION LIFT	
SIZE / DWG. NO.	REV
A 5260197	P
SCALE: 1:15	SHEET 3 OF 5

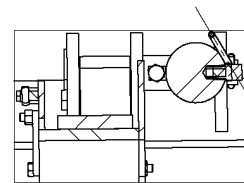
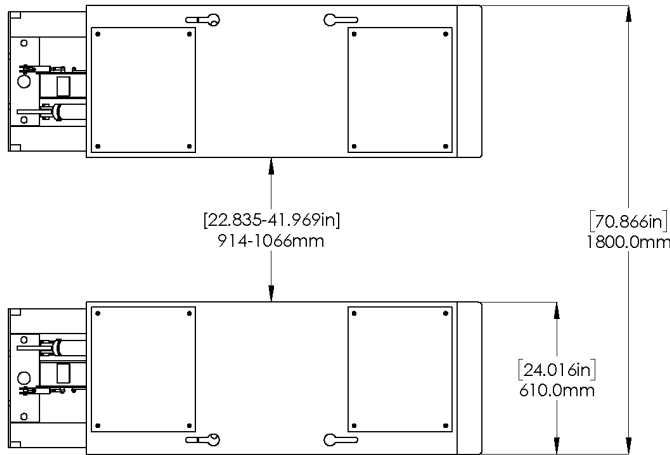

SECTION A-A
SCALE 1 : 5

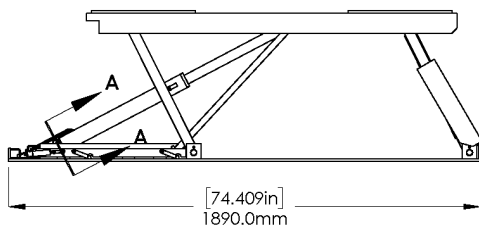

BP BendPak.	
1445 LEMONWOOD DR. SANTA PAULA, CA 93060	
TITLE: P9000LTF PRODUCTION LIFT	
SIZE / DWG. NO.	REV
A 5260197	P
SCALE: 1:20	SHEET 4 OF 5



1645 Lemonwood Drive
Santa Paula, CA 93060 USA