



Questions or Concerns

 support@meowanhome.com

MANUFACTURER

Shenzhen Guiyang Network Technology Co., Ltd

ADDRESS

1404K3, East Block, Shengtang Commercial Building,
Futian District, Shenzhen, China



Made In China

Rev_1.2_EN

meowant PET MONITOR

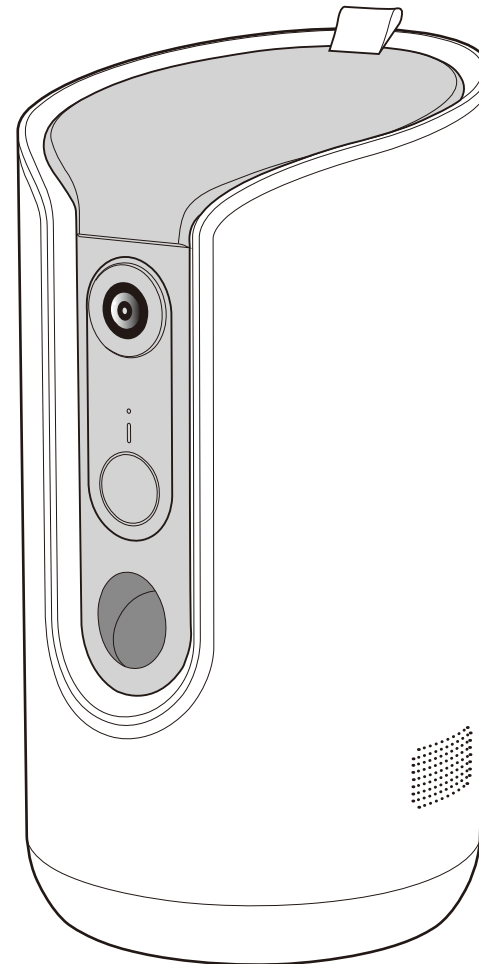

Model: MW-PM01
User Manual

CONTENTS

01 IMPORTANT SAFETY INSTRUCTIONS

03 EXPLORING PET MONITOR

05 USING PET MONITOR

10 CARE AND CLEANING

11 TROUBLESHOOTING GUIDE

13 WARRANTY AND SERVICE

IMPORTANT SAFETY INSTRUCTIONS



READ ALL INSTRUCTIONS BEFORE USE AND SAVE FOR FUTURE REFERENCE

When using an electrical appliance, especially when children are present, basic safety precautions should always be followed, including the following:

- This appliance is not intended for use by persons (including children) with reduced physical, sensory or mental capabilities, or lack of experience and knowledge, unless they have been given supervision or instruction concerning the use of the appliance by person responsible for their safety.
- Close attention is necessary when used by or near children. Children should be supervised to ensure that they do not play with the appliance.
- **DO NOT** operate the appliance if it has a damaged power cord or plug, or if it is malfunctioning or has been damaged in any manner.
- **DO NOT** immerse the cord, plug, or the appliance in water or other liquid or allow moisture to come into contact with these parts.
- **DO NOT** attempt to disassemble, repair, modify or replace any part of the appliance. No user serviceable parts inside. All servicing should be performed by qualified personnel only.
- **DO NOT** drop, hit, shake, or tumble the appliance.
- **DO NOT** use to dispense medication to your pets.
- **DO NOT** expose to liquid, moisture, dust, excessive heat, naked flame or direct sunlight.
- Protect the power cord from being walked on, pinched or chewed on by pets.
- Always unplug when not in use, and before cleaning, maintenance or servicing.
- Use **ONLY** the provided power adapter and charging cable.
- For indoor use only. Use the appliance only for intended household purposes as described in this User Manual.
- Dispose of all packaging materials properly. Keep away from children and pets.

FOR HOUSEHOLD USE ONLY

SAVE THESE INSTRUCTIONS

Specifications

Input	DC 5V --- 2A
Rated Power	4.5W Max
Treat Container	0.13gal / 0.5L
Treat Size	< 0.6in / 15mm, not sticky & not easily crumbled
Tossing Distance	1.6~3.3ft / 0.5~1m horizontal
Rotation Angle	0~355°
Active Pixels	2048(H) x 1536(V)
Field of View (H/V/D)	68° / 110° / 147°
IR Distance	Up to 33ft / 10m night vision
Audio	2-way audio (mic & speaker)
Wi-Fi	2.4GHz & 5GHz
Storage	Cloud storage, micro SD card (128GB Max, not included)
Operation Temperature	-4°F~122°F / -20°C~50°C

Exploring Your Litter Box



Check if all accessories are included. Contact us via email: support@meowanthome.com if there is any part missing or damaged.

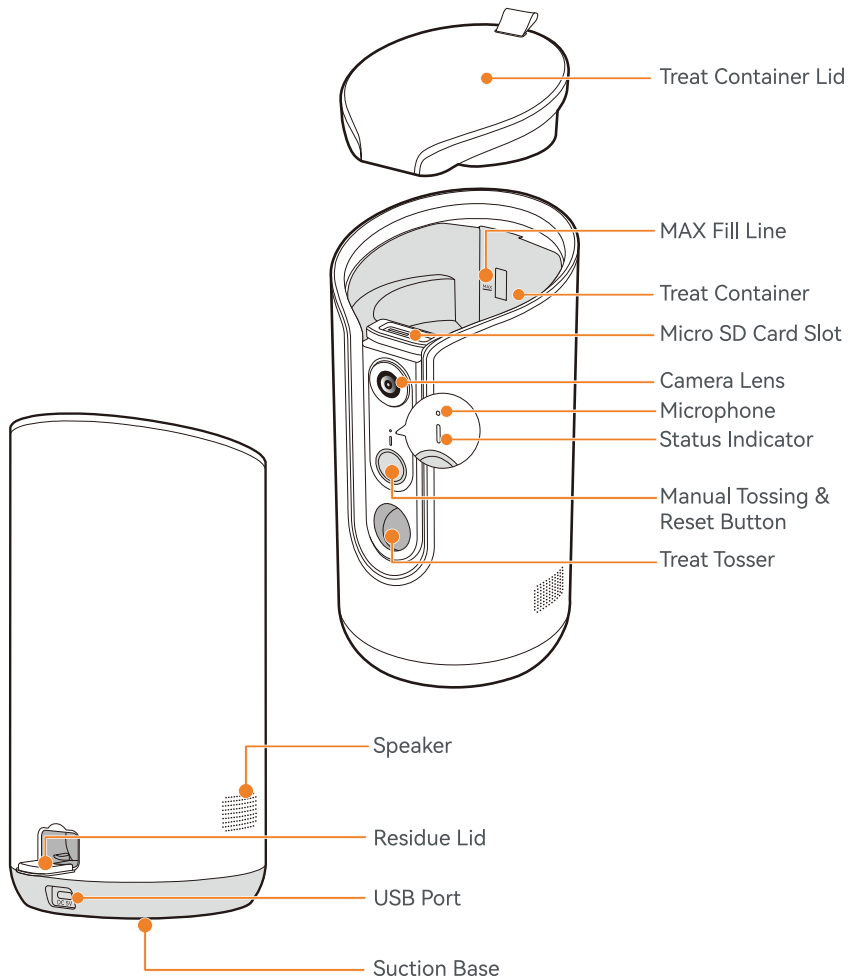

Status Indicator



Solid Blue
Online & in use



Flashing Red Slowly
Waiting for connection



Flashing Red Quickly
Setting up Wi-Fi



Solid Red
Boot up or offline



Reset Button

- Press once to toss manually.
- Hold for 5s to bring the monitor into pairing mode or reset.

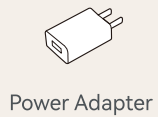
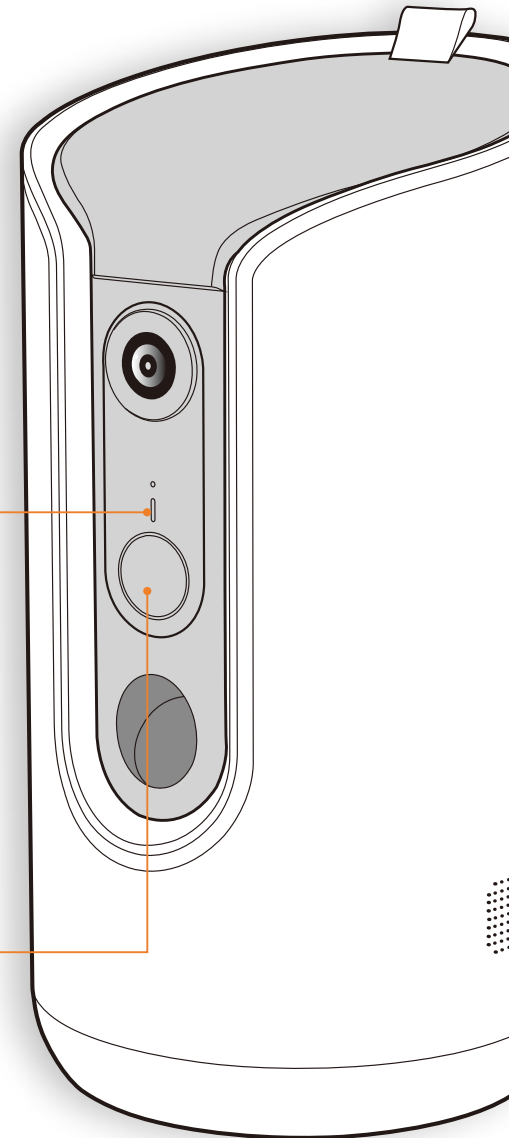

Power Adapter



USB-C Cable



Cleaning Brush



User Manual & Quick Start Guide

USING PET MONITOR

Wi-Fi Setup



- Make sure that your smart device is connected to a secure 2.4GHz or 5GHz network.
- DO NOT direct the camera lens to the sun.



For iOS

For Android



1

Download and install **Safeview** app, then sign up for an account.



2

- (1) Open the lid, add treats that are not sticky and not easily crumbled below the Max fill line.
- (2) If desired, insert a Micro SD card (128GB Max, not included) into the card slot.

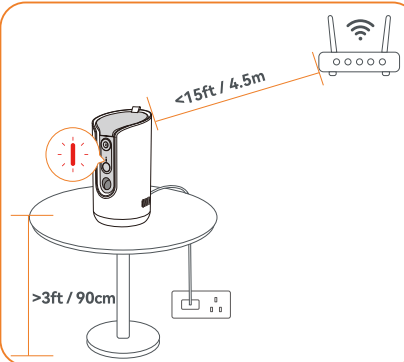

3

Pick a spot with strong Wi-Fi signal and plug in the monitor. Wait for the indicator to flash red.

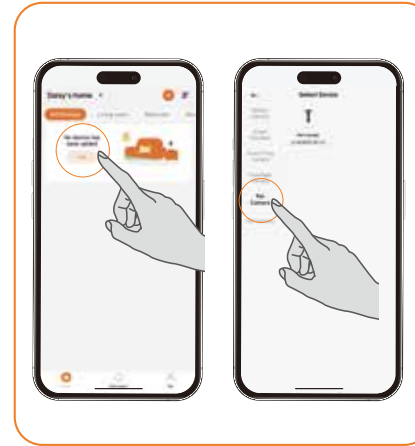

4

Open app, tap **Add Device**, then select **Pet Camera** from the list of options.

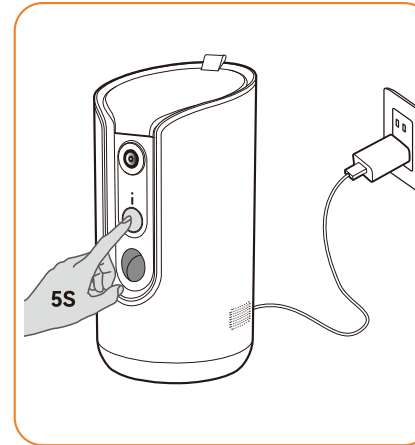

5

Hold **Reset** button for 5s to bring the monitor into pairing mode. Tap **Next** to continue.

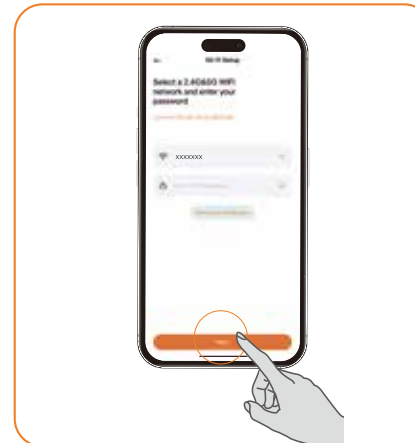

6

Select a 2.4GHz or 5GHz Wi-Fi and enter password. Tap **Next** to continue.



7

Tap **Next**, a QR code will be generated. Hold your phone at the 5-8in distance with the QR code facing the lens. Tap **Next**.

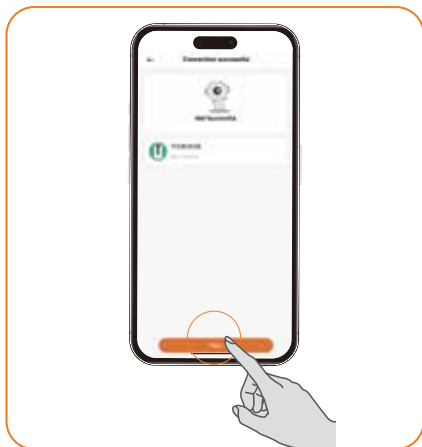

8

Wait until it connects and the indicator turns solid blue. Tap **Next**.



9

Select the family and location. Tap **Done** to complete setup.

Using with APP

Homepage

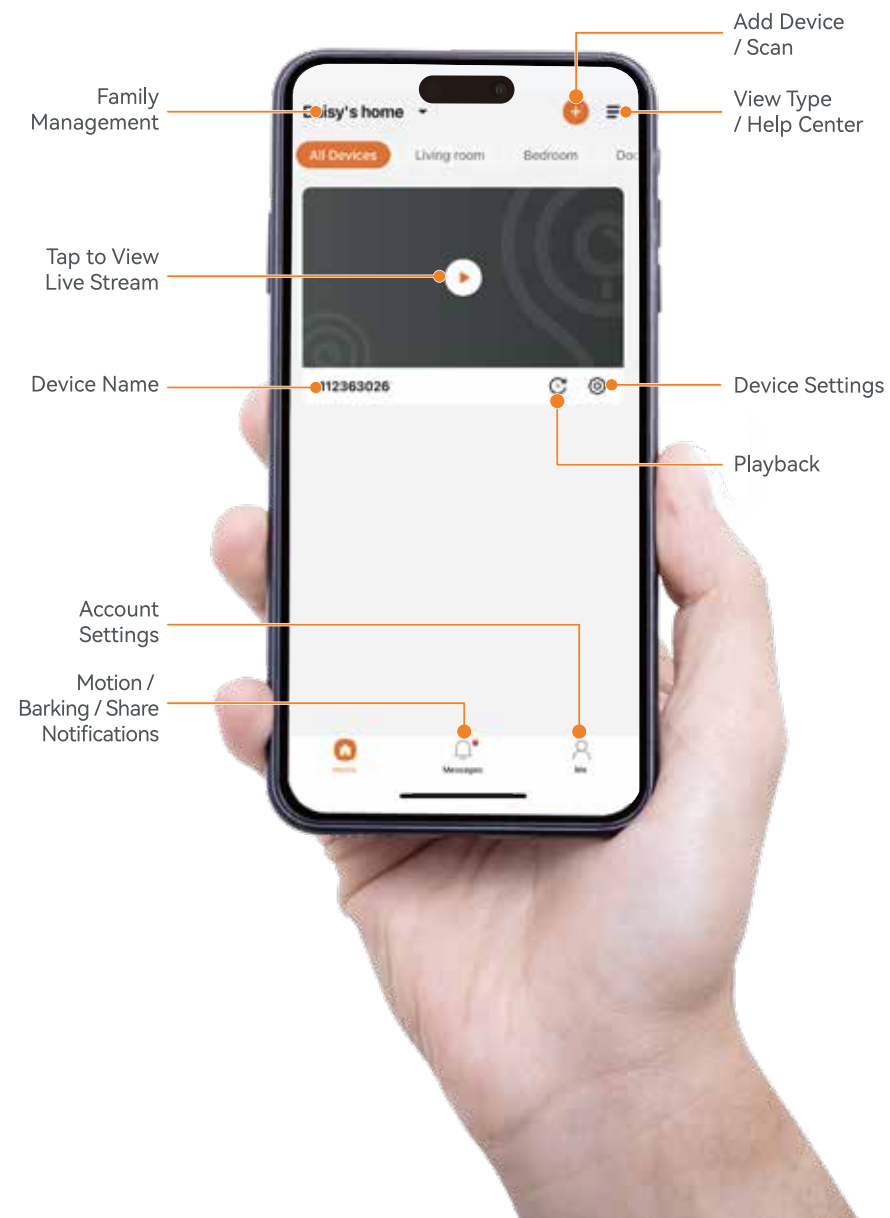

Add Device / Scan

View Type / Help Center

Family Management

Tap to View Live Stream

Device Name

Device Settings

Playback

Account Settings

Motion / Barking / Share Notifications

Live Stream

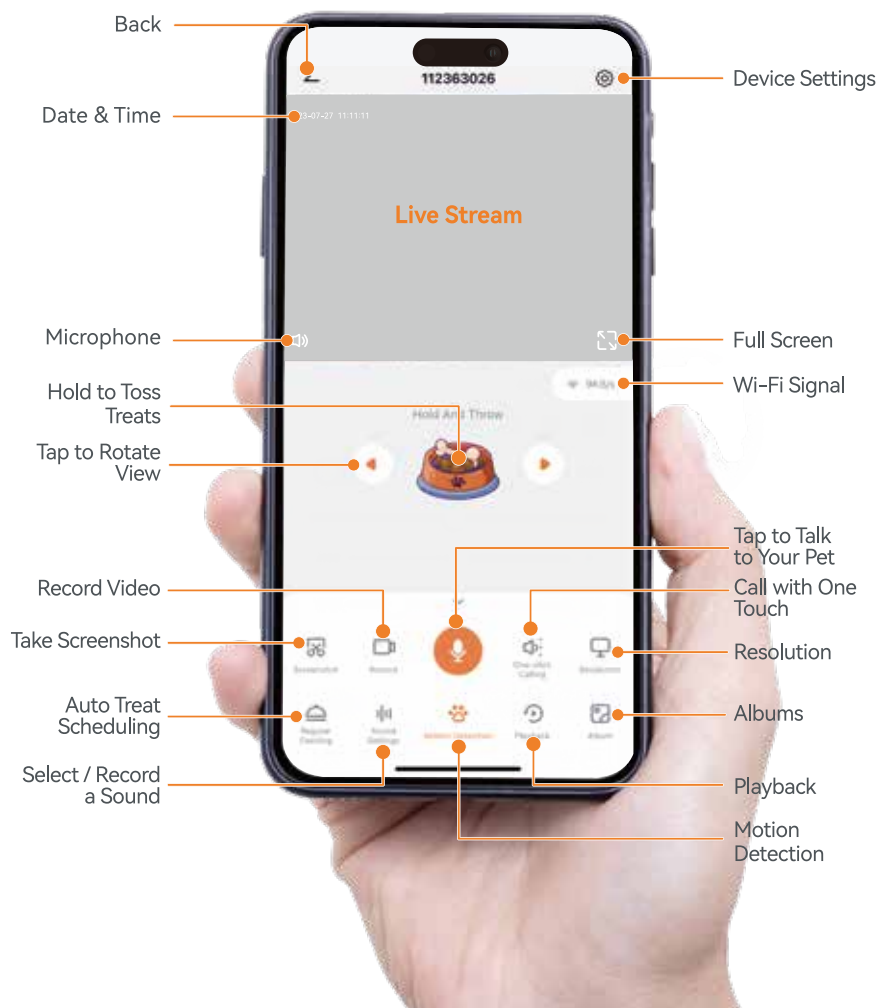

CARE AND CLEANING



- Always make sure the pet monitor is unplugged before cleaning.
- DO NOT rinse the container with water directly.
- To prevent clogging, we recommend that you clean the treat container regularly.



Treat Container

Open the container lid and empty out all the treats. Wipe clean the container with a soft, slightly damp cloth or clean with the included brush.

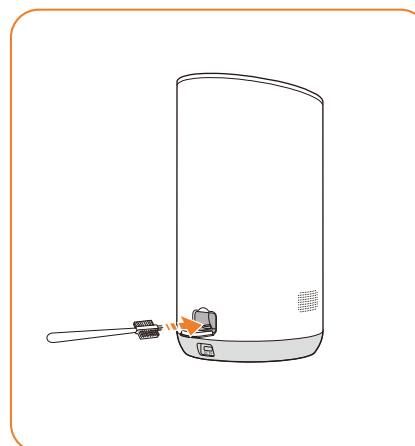

Food Residue

Open the residue lid, pour out or brush off the leftover scraps.

Introducing Monitor to Your Pet

- **Step 1 - Start with location.** Place the monitor where your pet tends to spend most of their time.
- **Step 2 - Toss treats manually.** Manually toss a treat in front of the monitor. Repeat until your pet eats the treats you tossed.
- **Step 3 - Toss treats with app.** Kneel beside the monitor and toss a treat through the app. Repeat until your pet eats the treat.
- **Step 4 - Toss treats remotely.** Toss a treat through the app remotely. Repeat until your pet eats the treat.

TROUBLESHOOTING GUIDE



The troubleshooting guide addresses the most common problems. If problems persist, feel free to contact the Customer Support via email: support@meowanthome.com

Q: Indicator does not light up.

- A:**
- Unplug and plug it back in to try again.
 - Make sure that you are using the original power adapter and that the cable is undamaged. If you no longer have the original power adapter, make sure to use the one that provides 5V/2A power only.
 - Try to reset by holding the Reset button for 5s.

Q: Fail to connect monitor.

- A:**
- Make sure that your mobile is connected to a secure 2.4GHz or 5GHz Wi-Fi network.
 - Make sure that your mobile and monitor are connected to the same Wi-Fi network.
 - Make sure that you have entered a correct Wi-Fi password and the monitor is under strong Wi-Fi signal.
 - Check if the monitor is linked to another device. Have the device unbound or hold the Reset button for 5s to reset.

Q: Can my family members and I connect to the monitor at the same time?

- A:** Yes, you can. But to protect your privacy, the monitor can only be linked to one account. If there are multiple users, it is recommended to share with a family group account.

Q: Fail to toss treats.

- A:**
- Make sure that the monitor is properly connected to power and network.
 - Make sure that the treats are of the right size (< 0.6in).
 - Check if the inner launcher is stuck. Empty out all the treats and clean out any leftover scraps. Shake to loosen the treats jammed inside and dump them out.

Q: Live stream screen flickering.

- A:** When there are multiple light sources around your monitor, it may cause the live stream screen flickering. Flickering is especially obvious in the presence of fluorescent lamps.

Q: Fail to detect SD card.

- A:**
- Insert the SD card (not included) before connecting to power.
 - Make sure that you are using a standard FAT32 SD card.
 - Check if the monitor is under strong Wi-Fi signal.

Q: Do I need an SD card?

- A:** The SD card is not necessary, you can use the monitor without an SD card. Motion detection events are automatically saved in the cloud. If you want to keep your videos for a longer time, we recommend getting an SD card so that the videos are stored locally and can be accessed anytime you want.

Q: Treats to use.

- A:** The best treats for use with the monitor are not sticky and not easily crumbled with a diameter of less than 0.6 inch. Avoid cutting the treats.

WARRANTY AND SERVICE



Thank you for choosing MeoWant Pet Monitor. This product is covered with MeoWant product and labor warranty for 12 months from the date of its original purchase.

The warranty will not apply in cases of:

- Accident, misuse, or repairs performed by unauthorized personnel.
- Any unit that has been tampered with or used for commercial purpose.
- Normal wear and tear of wearable parts.
- Use of force, damage caused by external influences.
- Damage caused by non-observance of the User Manual, e.g. connection to an unsuitable mains supply or non-compliance with the instructions.
- Partially or completely dismantled appliances.
- Defects caused by or resulting from damages from repairs, service, or alteration to the product or any of its parts that have been performed by a repair person not authorized.

We can only provide after sales service for products that are sold by MeoWant or MeoWant authorized retailers and distributors. If you have purchased your unit from a different place, please contact your seller for return and warranty issues.

*** Please have your order ID ready before contacting Customer**

Support via [email: support@meowanthome.com](mailto:support@meowanthome.com)

FCC Compliance

This device complies with Part 15 of the FCC Rules. Operation is subject to the following two conditions:

- (1) this device may not cause harmful interference, and
- (2) this device must accept any interference received, including interference that may cause undesired operation.

Warning: Changes or modifications not expressly approved by the party responsible for compliance could void the user's authority to operate the equipment.

NOTE: This equipment has been tested and found to comply with the limits for a Class B digital device, pursuant to Part 15 of the FCC Rules. These limits are designed to provide reasonable protection against harmful interference in a residential installation. This equipment generates uses and can radiate radio frequency energy and, if not installed and used in accordance with the instructions, may cause harmful interference to radio communications. However, there is no guarantee that interference will not occur in a particular installation. If this equipment does cause harmful interference to radio or television reception, which can be determined by turning the equipment off and on, the user is encouraged to try to correct the interference by one or more of the following measures:

- Reorient or relocate the receiving antenna.
- Increase the separation between the equipment and receiver.
- Connect the equipment into an outlet on a circuit different from that to which the receiver is connected.
- Consult the dealer or an experienced radio/TV technician for help.

FCC Radiation Exposure Statement

This equipment complies with FCC radiation exposure limits set forth for an uncontrolled environment. This equipment should be installed and operated with minimum distance 20cm between the radiator & your body.

