

CWT 1640 Premium

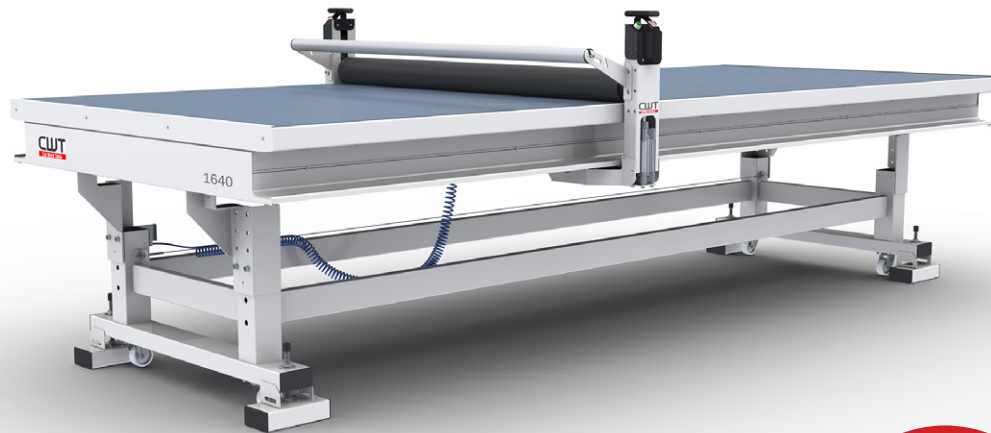

FACTS

| | |
|---|---|
| PART NO | CWT 164010 |
| DESCRIPTION | CWT 1640 Regular |
| TABLE LENGTH | 4000mm (13ft.in.) |
| TABLE WIDTH | 1600mm (5ft. 3in.) |
| LENGTH OF WORKING AREA | 3560mm (11ft. 8in.) |
| WIDTH OF WORKING AREA/ROLLER WIDTH | 1560mm (5ft. 1.5in.) |
| OVERALL WIDTH | 1925mm (6ft. 4in.) |
| OVERALL HEIGHT | 1620mm (5ft. 4in.) |
| MAX. THICKNESS OF SUBSTRATE | 0-70mm (0-2.8in.) |
| WORK HEIGHT | 744-950mm (2ft. 5in. - 3ft. 1in.) |
| WORK HEIGHT ADJUSTEMENT* | Manual |
| BED SURFACE | Tempered safety glass |
| POWER SUPPLY** | 230V/50Hz (10A) or 120V/60Hz (15A) |
| REQUIRED AIR SUPPLY | 6-8bar (87-116psi) |
| NET WEIGHT | 485kg (1069lbs) |
| GROSS WEIGHT | 640kg (1411lbs) |
| PACKING DIMENSIONS | 4150 x 550 x 2100mm (13ft. 8in. x 22in. x 6ft. 10in.) |
| WARRANTY | 3 years |

FEATURES

| | |
|------------------------------------|--------|
| CUTTING MAT, SELF HEALING | Yes |
| LED ILLUMINATED LIGHT TABLE | Yes |
| ROLL HOLDER FOR GLIDE BEAM | Yes |
| EXTRA LOWER ROLL HOLDER | Yes |
| TABLE TOP ROLL HOLDER | Yes |
| SIDE POCKETS | Yes |
| SILENT COMPRESSOR | Yes |
| CASTERS | Yes |
| LEVELING FEET | Yes |
| ELO PREMIUM LIFT KIT*** | Option |

* Select 1 of 4 fixed heights at installation
 ** Only when including Premium upgrade kit
 *** ELO premium lift kit: upgrade to a fully electrical height adjustable worktable

CWT 1630 Regular



FACTS

| | |
|---|--|
| PART NO | CWT 163010 |
| DESCRIPTION | CWT 1630 Regular |
| TABLE LENGTH | 3000mm (9ft. 10in.) |
| TABLE WIDTH | 1600mm (5ft. 3in.) |
| LENGTH OF WORKING AREA | 2560mm (8ft. 5in.) |
| WIDTH OF WORKING AREA/ROLLER WIDTH | 1560mm (5ft. 1.5in.) |
| OVERALL WIDTH | 1925mm (6ft. 4in.) |
| OVERALL HEIGHT | 1620mm (5ft. 4in.) |
| MAX. THICKNESS OF SUBSTRATE | 0-70mm (0-2.8in.) |
| WORK HEIGHT | 744-950mm (2ft. 5in. - 3ft. 1in.) |
| WORK HEIGHT ADJUSTEMENT* | Manual |
| BED SURFACE | Tempered safety glass |
| POWER SUPPLY** | 230V/50Hz (10A) or 120V/60Hz (15A) |
| REQUIRED AIR SUPPLY | 6-8bar (87-116psi) |
| NET WEIGHT | 395kg (871lbs) |
| GROSS WEIGHT | 540kg (1191lbs) |
| PACKING DIMENSIONS | 3360 x 550 x 2100mm (11ft. x 22in. x 6ft. 10in.) |
| WARRANTY | 3 years |

FEATURES

| | |
|------------------------------------|--------|
| CUTTING MAT, SELF HEALING | Yes |
| LED ILLUMINATED LIGHT TABLE | Option |
| ROLL HOLDER FOR GLIDE BEAM | Yes |
| EXTRA LOWER ROLL HOLDER | Option |
| TABLE TOP ROLL HOLDER | Option |
| SIDE POCKETS | Yes |
| SILENT COMPRESSOR | Yes |
| CASTERS | Yes |
| LEVELING FEET | Yes |
| PREMIUM UPGRADE KIT**** | Option |
| ELO PREMIUM LIFT KIT**** | Option |

* Select 1 of 4 fixed heights at installation

** Only when including Premium upgrade kit

*** Premium upgrade kit includes: LED illuminated light table, extra lower roll holder and roll holder for table top

**** ELO premium lift kit: upgrade to a fully electrical height adjustable worktable

CWT 1640 Regular

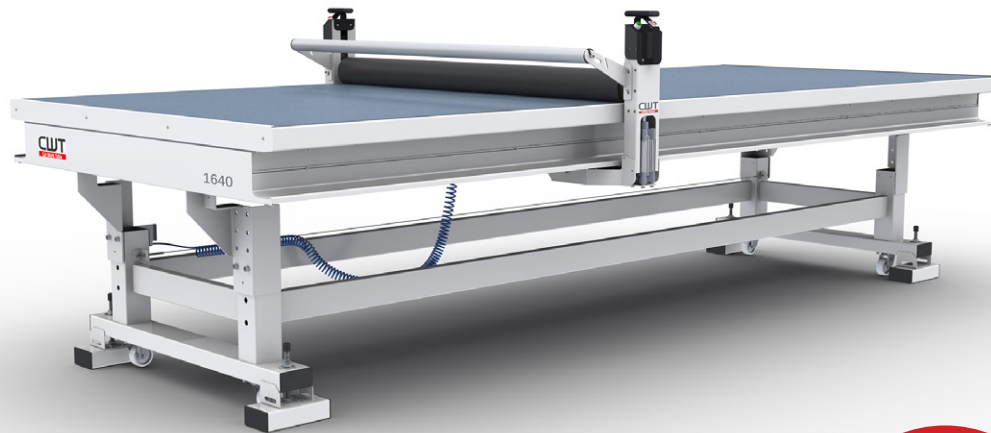

FACTS

| | |
|---|--|
| PART NO | CWT 164010 |
| DESCRIPTION | CWT 1640 Regular |
| TABLE LENGTH | 4000mm (13ft.in.) |
| TABLE WIDTH | 1600mm (5ft. 3in.) |
| LENGTH OF WORKING AREA | 3560mm (11ft. 8in.) |
| WIDTH OF WORKING AREA/ROLLER WIDTH | 1560mm (5ft. 1.5in.) |
| OVERALL WIDTH | 1925mm (6ft. 4in.) |
| OVERALL HEIGHT | 1620mm (5ft. 4in.) |
| MAX. THICKNESS OF SUBSTRATE | 0-70mm (0-2.8in.) |
| WORK HEIGHT | 744-950mm (2ft. 5in. - 3ft. 1in.) |
| WORK HEIGHT ADJUSTEMENT* | Manual |
| BED SURFACE | Tempered safety glass |
| POWER SUPPLY** | 230V/50Hz (10A) or 120V/60Hz (15A) |
| REQUIRED AIR SUPPLY | 6-8bar (87-116psi) |
| NET WEIGHT | 485kg (1069lbs) |
| GROSS WEIGHT | 640kg (1411lbs) |
| PACKING DIMENSIONS | 4150 x 550 x 2100mm (13ft. 8in. x 22in. x 6ft. 10in.) |
| WARRANTY | 3 years |

FEATURES

| | |
|------------------------------------|--------|
| CUTTING MAT, SELF HEALING | Yes |
| LED ILLUMINATED LIGHT TABLE | No |
| ROLL HOLDER FOR GLIDE BEAM | Yes |
| EXTRA LOWER ROLL HOLDER | Yes |
| TABLE TOP ROLL HOLDER | No |
| SIDE POCKETS | Yes |
| SILENT COMPRESSOR | Yes |
| CASTERS | Yes |
| LEVELING FEET | Yes |
| ELO PREMIUM LIFT KIT*** | Option |

* Select 1 of 4 fixed heights at installation

** Only when including Premium upgrade kit

*** ELO premium lift kit: upgrade to a fully electrical height adjustable worktable

CWT 1630 Premium



FACTS

| | |
|---|--|
| PART NO | CWT 163010 |
| DESCRIPTION | CWT 1630 Regular |
| TABLE LENGTH | 3000mm (9ft. 10in.) |
| TABLE WIDTH | 1600mm (5ft. 3in.) |
| LENGTH OF WORKING AREA | 2560mm (8ft. 5in.) |
| WIDTH OF WORKING AREA/ROLLER WIDTH | 1560mm (5ft. 1.5in.) |
| OVERALL WIDTH | 1925mm (6ft. 4in.) |
| OVERALL HEIGHT | 1620mm (5ft. 4in.) |
| MAX. THICKNESS OF SUBSTRATE | 0-70mm (0-2.8in.) |
| WORK HEIGHT | 744-950mm (2ft. 5in. - 3ft. 1in.) |
| WORK HEIGHT ADJUSTEMENT* | Manual |
| BED SURFACE | Tempered safety glass |
| POWER SUPPLY** | 230V/50Hz (10A) or 120V/60Hz (15A) |
| REQUIRED AIR SUPPLY | 6-8bar (87-116psi) |
| NET WEIGHT | 395kg (871lbs) |
| GROSS WEIGHT | 540kg (1191lbs) |
| PACKING DIMENSIONS | 3360 x 550 x 2100mm (11ft. x 22in. x 6ft. 10in.) |
| WARRANTY | 3 years |

FEATURES

| | |
|------------------------------------|--------|
| CUTTING MAT, SELF HEALING | Yes |
| LED ILLUMINATED LIGHT TABLE | Yes |
| ROLL HOLDER FOR GLIDE BEAM | Yes |
| EXTRA LOWER ROLL HOLDER | Yes |
| TABLE TOP ROLL HOLDER | Yes |
| SIDE POCKETS | Yes |
| SILENT COMPRESSOR | Yes |
| CASTERS | Yes |
| LEVELING FEET | Yes |
| ELO PREMIUM LIFT KIT*** | Option |

* Select 1 of 4 fixed heights at installation

** Only when including Premium upgrade kit

*** ELO premium lift kit: upgrade to a fully electrical height adjustable worktable

CWT 1428 Advantage



FACTS

| | |
|---|--|
| PART NO | CWT142810 |
| DESCRIPTION | CWT 1428 Advantage |
| TABLE LENGTH | 2850mm (9ft. 4in.) |
| TABLE WIDTH | 1450mm (4ft. 9in.) |
| LENGTH OF WORKING AREA | 2570mm (8ft. 5in.) |
| WIDTH OF WORKING AREA/ROLLER WIDTH | 1400mm (4ft. 7in.) |
| OVERALL WIDTH | 1815mm (5ft. 11in.) |
| OVERALL HEIGHT | 1050mm (3ft. 5in.) |
| MAX. THICKNESS OF SUBSTRATE | 0-70mm (0-2.8in.) |
| WORK HEIGHT | 830 – 1010mm (2ft. 9in. – 3ft. 4in.) |
| WORK HEIGHT ADJUSTEMENT * | Manual |
| BED SURFACE | Tempered safety glass |
| POWER SUPPLY | 230V/50Hz (10A) or 120V/60Hz (15A) |
| REQUIRED AIR SUPPLY | 6-8bar (87-116psi) |
| NET WEIGHT | |
| GROSS WEIGHT | 400kg (880lbs) |
| PACKING DIMENSIONS | 3000 x 380 x 2100mm (9ft. 10in. x 1ft. 3in. x 7ft.) |
| WARRANTY | 3 years |

FEATURES

| | |
|------------------------------------|--------|
| CUTTING MAT, SELF HEALING | Yes |
| LED ILLUMINATED LIGHT TABLE | Yes |
| ROLL HOLDER FOR GLIDE BEAM | Yes |
| TABLE TOP ROLL HOLDER | Option |
| SILENT COMPRESSOR | Option |
| CASTERS | Yes |

* Select 1 of 4 fixed heights at installation

CWT 1016 Advantage



FACTS

| | |
|---|---|
| PART NO | CWT 101610 |
| DESCRIPTION | CWT 1016 Advantage |
| TABLE LENGTH | 1640mm (5ft. 4in.) |
| TABLE WIDTH | 990mm (3ft. 3in.) |
| LENGTH OF WORKING AREA | 1340mm (4ft. 5in.) |
| WIDTH OF WORKING AREA/ROLLER WIDTH | 950mm (3ft. 1in.) |
| OVERALL WIDTH | 1195mm (3ft. 11in.) |
| OVERALL HEIGHT | 1090mm (3ft. 7in.) |
| MAX. THICKNESS OF SUBSTRATE | 0-70mm (0-2.8in.) |
| WORK HEIGHT | 830 – 1010mm (2ft. 5in. – 3ft. 1in.) |
| WORK HEIGHT ADJUSTEMENT * | Manual |
| BED SURFACE | Tempered safety glass |
| POWER SUPPLY | 230V/50Hz (10A) or 120V/60Hz (15A) |
| REQUIRED AIR SUPPLY | 6-8bar (87-116psi) |
| NET WEIGHT | |
| GROSS WEIGHT | 240kg (529lbs) |
| PACKING DIMENSIONS | 1400 x 550 x 1900mm (4ft. 7in. x 1ft. 10in. x 6ft. 4in.) |
| WARRANTY | 3 years |

FEATURES

| | |
|------------------------------------|--------|
| CUTTING MAT, SELF HEALING | Yes |
| LED ILLUMINATED LIGHT TABLE | Yes |
| ROLL HOLDER FOR GLIDE BEAM | Yes |
| TABLE TOP ROLL HOLDER | Option |
| SILENT COMPRESSOR | Option |
| WHEELS | Yes |
| TOOL SHELF | Yes |

* Select 1 of 4 fixed heights at installation