



RACING PORTFOLIO 2024

# INDEX

## COMPANY PROFILE

OVER 20 YEARS OF TECHNOLOGICAL EXCELLENCE IN MOTORSPORT	3
SCHUBERTH	4
ONE LEGENDARY SHAPE	6

## HELMETS

<b>SF3</b> (FIA 8860-2018 ABP)	8
STANDARD INNER LINING SPARE PARTS	10
INTERIOR COLOR OPTIONS	11
<b>SF4</b> (FIA 8860-2018)	12
GT SETUPS	13
STANDARD INNER LINING AND NOISE REDUCTION SPARE PARTS	15
INTERIOR COLOR OPTIONS	16
<b>SP1 CARBON</b> (FIA 8859-2015 SNELL SA2020)	18
GT SETUPS	19
STANDARD INNER LINING AND NOISE REDUCTION SPARE PARTS	21
<b>SK1</b> (SNELL FIA CMR 2016)	23
STANDARD INNER LINING AND NOISE REDUCTION SPARE PARTS	25

## ACCESSORIES RANGE

VISORS	29
HIGH CONTRAST VISORS TECHNOLOGY	30
VISOR FITTINGS	31
SCOOPS	32
SPOILERS	33
EXTRA ITEMS	34
RADIO HELMET KITS	36
EARPLUGS	37

# OVER 20 YEARS OF TECHNOLOGICAL EXCELLENCE IN MOTORSPORT

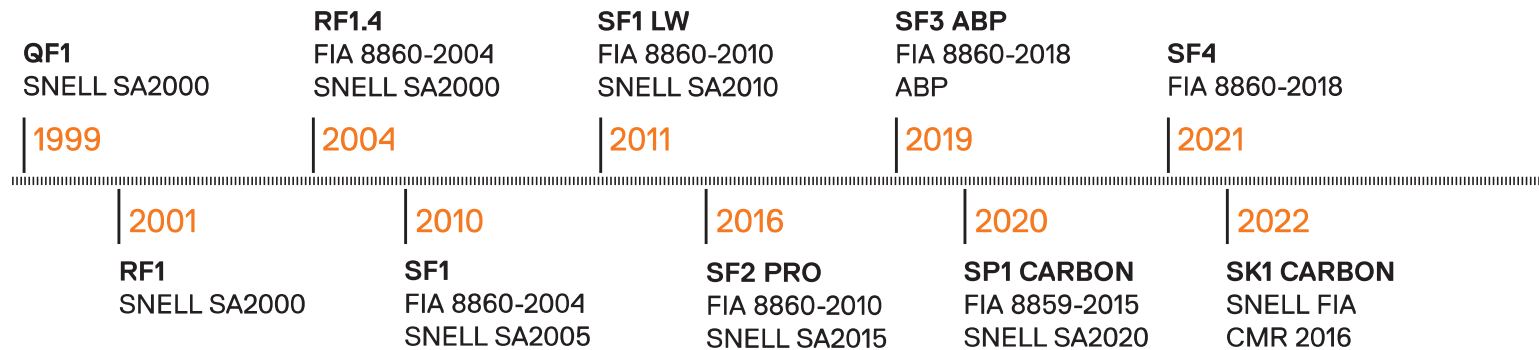

Michele Alboreto | Fernando Alonso | Luca Badoer | Rubens Barrichello | Timo Bernhard | Jules Bianchi | Frank Biela | Mattias Ekström | Simone Faggioli | Giancarlo Fisichella | Denny Hamlin | Kevin Harvick | Nick Heidfeld | Jay Howard | Nico Hülkenberg | Jimmie Johnson | Charlie Kimball | Tom Kristensen | Johan Kristoffersson | Daniil Kvyat | Cooper MacNeil | Felipe Massa | Danica Patrick | Sergio Perez | Emanuele Pirro | Kimi Räikkönen | René Rast | Daniel Ricciardo | Nico Rosberg | Carlos Sainz jr | Michael Schumacher | Mick Schumacher | Ralf Schumacher | Bruno Spengler | Max Verstappen | Bubba Wallace | Mark Webber | Pascal Wehrlein | Marco Wittmann

# SCHUBERTH

Almost 100 years dedicated to the development of head protection solutions and 20 years of providing top drivers in F1, IndyCar and other top series, with the safest and most technologically advanced helmets.

Utilizing our in house carbon, wind tunnel, and io, and load test labs, the R&D department has brought together unparalleled experience to produce state of the art helmets. Safety, comfort, aerodynamic tuning, noise reduction and optional integrated electronics have all been combined to make the **SF3 ABP**, **SF4**, **SP1 CARBON**, and **SK1 CARBON** the ultimate carbon helmets available.



Each **SF3 ABP**, **SF4**, **SP1 CARBON**, and **SK1 CARBON** starts with our exclusive, masterfully handcrafted, autoclave cured, carbon fiber shells. This provides a unique helmet combining light weight, solid construction and superior safety in the iconic **SCHUBERTH** design.



Every **SCHUBERTH** helmet is produced in our own factory in Italy, by the same hands that produce the masterpiece **SF3 FIA 8860 - 2018 ABP** helmets used by F1 drivers.



The entire range of **SCHUBERTH** helmets and accessories derive from Schubert's twenty years of experience in Formula 1®.





# ONE LEGENDARY SHAPE 20 YEARS OF EVOLUTION

## FULL CARBON SHELL

Lightweight, hand laid carbon, autoclave cured shell.

## 16 VENTILATION CHANNELS ON THE SHELL

Optimum circulation is achieved through aerodynamic design and air flow channels built into the EPS, providing the ideal flow for intake of cool air and exhaust for hot air.

In open air, the helmet feeds 14 liters of fresh air per second at 100 km/h.

## 3 MM THICK 3D INJECTED VISOR

Injected visor directly derived from F1 expertise eliminates typical distortion.

19 different visors available from transparent to dark with several mirroring multi-layer mirroring coating options and the new High Contrast options.

All standard visors are Pinlock® 120 lens equipped providing optimal fog resistant performance. Tear-off buttons are also installed.

## VISOR LOCK SYSTEM

Two-stage visor lock ensures the visor always closes symmetrically and therefore securely. Stage One lets in a small amount of air while the visor is still securely locked. Stage Two creates a firm visor seal that will keep out fine dust or water.



SF3  
8860-2018 ABP



SF4  
8860-2018



SP1 Carbon  
8859-2015 SA2020



SK1 Carbon  
SNELL FIA CMR 2016

# HELMETS

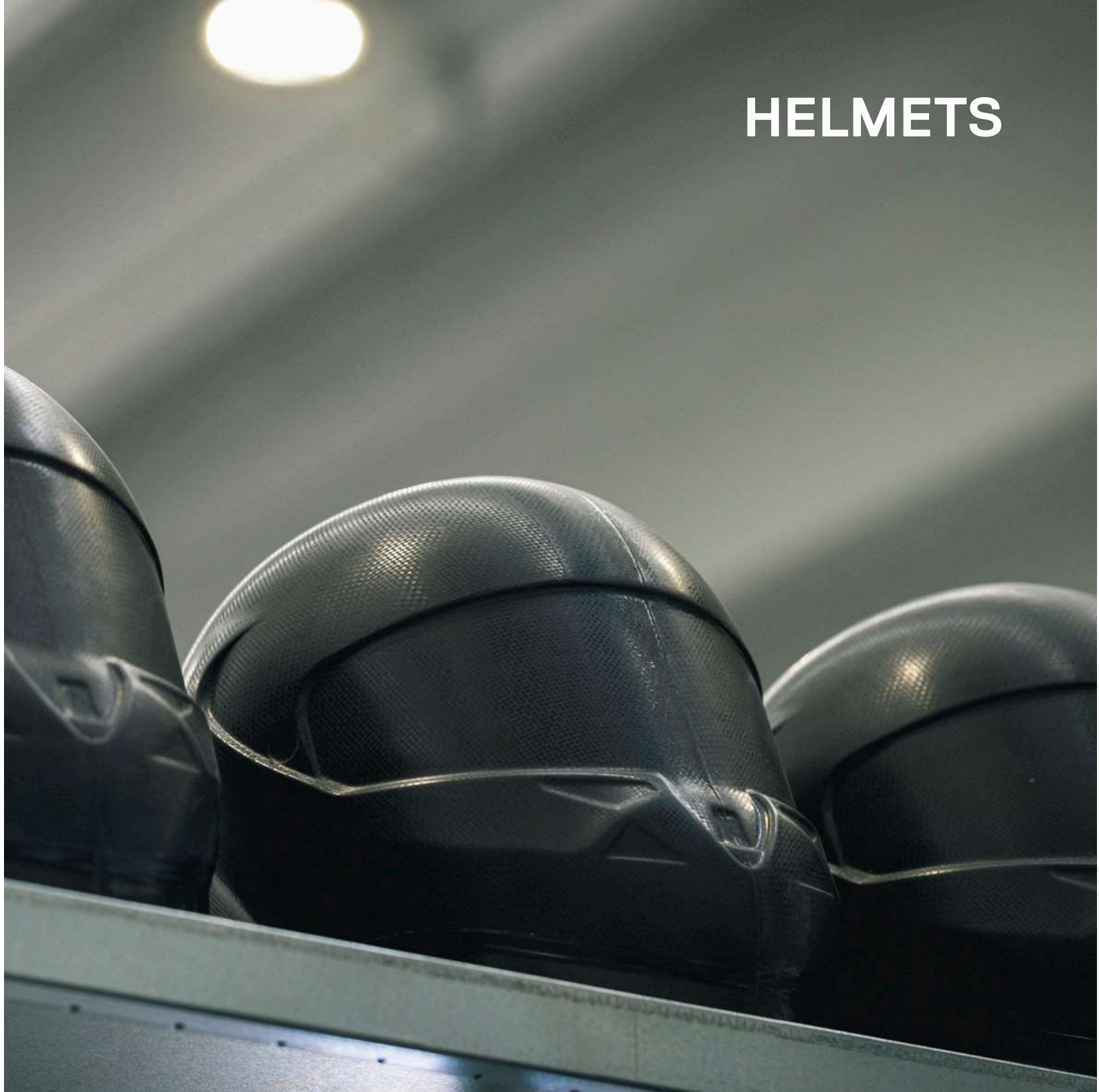

# SF3

FIA 8860-2018 ABP



**SF3 ABP** is offered as a tailor made program, which allows drivers to build a helmet around their comfort and functional needs. Basic customizations may be chosen from the catalog. Optimal customization is realized by working with expert Schubert technicians experienced in working with the needs of top drivers.

Please contact your Schubert Premium dealer to customize your fitting.

Medium shell	M\57 - L\58	weight 1.420 g +/- 30 g 3.13 lb +/- 1.05 oz
--------------	-------------	--



**SF3 ABP** represents the pinnacle of SCHUBERTH racing helmet technology. A handcrafted masterpiece created to respond to the new FIA top-end helmet standard 8860-2018 ABP: the most demanding standard in the racing industry, established to guarantee the highest safety level in the world.



With **SF3 ABP**, SCHUBERTH introduces a number of safety benefits unthinkable just few years ago, including advanced ballistic protection and increased energy absorption.



**SF3 ABP** adapts to the specific needs of the driver, in a personalized construction process, offering unparalleled comfort and exclusive fine tuning.



STANDARD INNER LINING

Helmet Shell	MEDIUM		
Helmet size (cm)	57	58	SPARE PARTS
Cheekpad size (mm)	35	25	20
Top crown pad (mm)	6		10

Cheek pads



- 10100012242 20 mm
- 10100012241 25 mm
- 10100012240 35 mm

Top crown pad

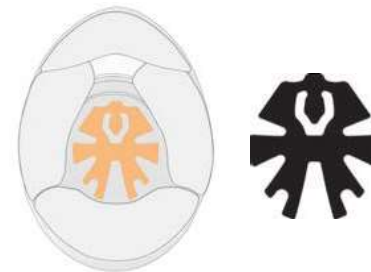

- 10100012243 6 mm
- 10100012244 10 mm

Wind deflector

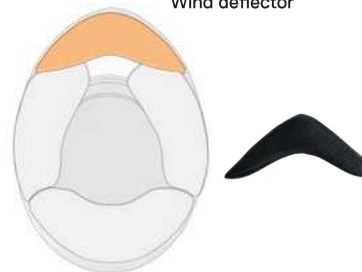

- 10100011951

STANDARD INTERIOR COLOR



Standard Black



INDIVIDUAL PROGRAM COLORS



White



Platino Grey



Foca Grey



Royal Blue



Bandiera Green

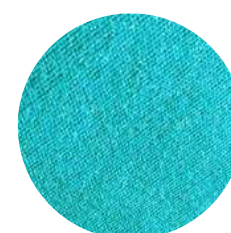

Turquoise



Geranio Red



Sole Yellow

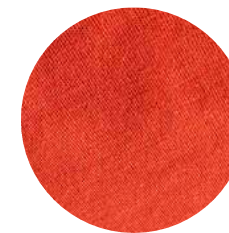

Clementina Orange

\*Colors may differ from what is shown in this catalog

# SF4

FIA 8860-2018



SHELL	SIZES	WEIGHT
medium shell	XS\54 - S\55 - M\57 - L\58-59	1.260 g +/- 30 g 2.78 lb +/- 1.05 oz
large shell	L+\60-61 - XL\61+	1.370 g +/- 30 g 2.99 lb +/- 1.05 oz

# NEW GT SETUPS



SF4 helmet is available with **GT VISOR** and **SUN SCREEN** optional accessories

## GT VISOR SETUP



GT VISOR  
+  
LOCKING CAM COVER  
(all colors available at pag 29)

## SUN SCREEN SETUP



SUN SCREEN  
+  
LOCKING CAM COVER  
(see pag 31)



### **8860-2018 HELMET**

Highest standards available complying with the latest FIA specifications.

### **TOP LEVEL**

Developed for perfect fitment and comfort, the SF4 is ideal for long run with Prototype and GT cars or on single seater open cockpit where ABP homologation is not requested.

### **CUSTOMIZATION**

With a wide range of accessories, the SF4 can adapt to meet driver's communication, comfort, aerodynamics, and aesthetic needs.



**STANDARD INNER LINING**

Helmet Shell	MEDIUM				LARGE		SPARE PARTS
Helmet size (cm)	54	55	57	58	60/61	61+	
Cheekpad size (mm)	35	30	25	20	30	25	
Top crown pad (mm)	15		7		9	7	

Cheek pads



Cheek pads std in black - available also in BLUE, RED and WHITE

Top crown pad

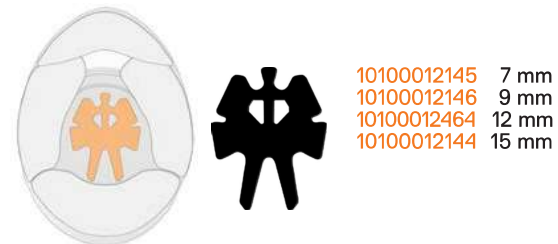

Wind deflector



Wind deflector std in black - available also in BLUE, RED and WHITE





STANDARD INTERIOR COLOR



Standard Black

INDIVIDUAL PROGRAM COLORS



Royal Blue



Geranio Red



White

Please contact your Schubert Premium dealer to customize your fitting.

\*Colors may differ from what is shown in this catalog





# SP1 CARBON

FIA 8859-2015 SNELL SA2020



SHELL	SIZES	WEIGHT
medium shell	XS\54 - S\55 - M\57 - L\58-59	1.370g +/- 30 g 3,02 lb +/- 1.05 oz
large shell	L+\60-61 - XL\62 - XXL\63	1.400 g +/- 30 g 3.08 lb +/- 1.05 oz



# NEW GT SETUPS



**SP1 CARBON** helmet is available with **GT VISOR** and **SUN SCREEN** optional accessories

## GT VISOR SETUP

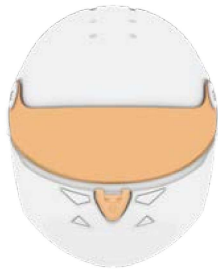

GT VISOR  
+  
LOCKING CAM COVER  
(all colors available at pag 29)

## SUN SCREEN SETUP



SUN SCREEN  
+  
LOCKING CAM COVER  
(see pag 31)

### COMMUNICATION SYSTEM READY

Radio communications systems are seamlessly integrated using proven techniques such as cable ducts in the cheek pads and recessed indents that provide a comfortable spot for ears.

A full selection of plug&play integrated electronics are available as an option.

### EXCEPTIONAL COMFORT

Comfort has been carefully studied thanks to Schubert's great experience within the racing industry. The result is a high-level, truly high-end experience.

### ACCESSORIES

SP1 CARBON has a large accessories catalog full of solutions to adapt the helmet to the needs of all racers, from amateur to professional.



# SP1 CARBON

FIA 8859-2015 SNELL SA2020

## STANDARD INNER LINING AND NOISE REDUCTION SPARE PARTS

### STANDARD INNER LINING

Helmet Shell	MEDIUM				LARGE			SPARE PARTS
Helmet size (cm)	54	55	57	58-59	60/61	62	63	
Cheekpad size (mm)	35	30	25	20	30	25	20	15
Top crown pad (mm)	15		7		9	7		12

Cheek pads

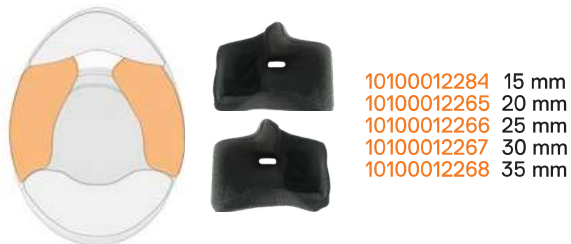

Cheek pads std in black - available also in BLUE, RED and WHITE

Top crown pad

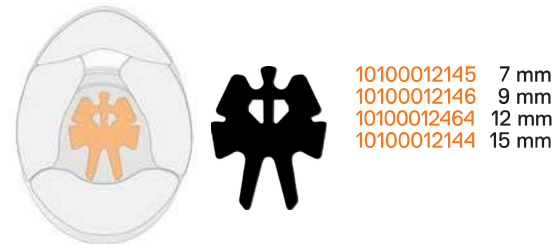

Wind deflector



Wind deflector std in black - available also in BLUE, RED and WHITE







# SK1 CARBON

SNELL FIA CMR 2016



SHELL	SIZES	WEIGHT
Small shell	XXS/52-53 - XS/54-55 - S/56	1.090 g +/- 30 g* 2.4 lb +/- 1.05 oz*
Medium shell	M/57 - L/58-59 - L+/59+	1.190 g +/- 30 g* 2.62 lb +/- 1.05 oz*

\*weight including 3 mm thick visor with pinlock and 4 small scoops



### SNELL FIA CMR 2016

SK1 CARBON is the first Schuberth CMR helmet. Carbon helmet is finished in a matte clear coat, and includes top air scoops as standard.

### OUR EXPERIENCE AT YOUR SUPPORT

The lightweight, hand laid carbon, and autoclave cured shell, is derived from our experience gained in Formula 1, and is specifically developed for the CMR homologation. The SK1 helmet is produced with the same technologies used for the FIA 8860-2018 models, included injection-molded 3mm FIA homologated visor with symmetrical opening and Pinlock® 120 mechanical anti-fog, ventilation system, and aramid chinstrap.

### EXCEPTIONAL COMFORT

SK1 benefits from all Schuberth experience in making safe and comfortable helmets.

SK1 has dedicated interiors designed specifically to meet the needs of all future champions.



# SK1 CARBON

SNELL FIA CMR 2016

## STANDARD INNER LINING AND NOISE REDUCTION SPARE PARTS

### STANDARD INNER LINING

Helmet Shell	SMALL			MEDIUM		
Helmet size (cm)	52/53	54/55	56	57	58/59	59+
Cheekpad size (mm)*	35	25	20	25	20	15
Top crown pad (mm)	15	9		9		

\*Cheek pads not interchangeable between shell sizes

Cheek pads



small shell  
 10100012401 20 mm  
 10100012400 25 mm  
 10100012399 35 mm  
 medium shell  
 10100012404 15 mm  
 10100012403 20 mm  
 10100012402 25 mm

Top crown pad



10100012146 9 mm  
 10100012144 15 mm

Wind deflector



10100012415

DGESTONE









# ACCESSORIES RANGE



# VISORS

All standard visors are 3mm injected, equipped with a Pinlock® 120 fog resistant lens, clear tear-off buttons, and clear locking lever. Rain visors are equipped with adhesive fog resistant lens, rubber trim, clear tear-off buttons, and clear locking lever. All visors for GT SETUP are 3mm thermoformed supplied with locking cam cover.

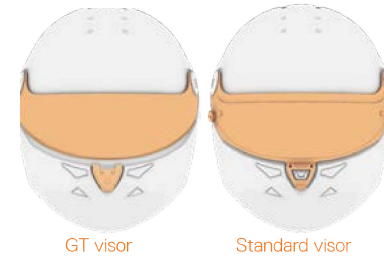

Clear  
1010008102  
Clear High Contrast  
1010008203



**NEW** GT Light smoked  
1010008227      Light smoked  
1010008104



Dark smoked  
1010008105



Clear mirrored multilayer  
RED  
1010008111  
Clear mirrored multilayer  
RED High Contrast  
1010008204



**NEW** GT Light smoked mirrored  
multilayer RED  
1010008229      Light smoked mirrored  
multilayer RED  
1010008106  
Light smoked mirrored multi-  
layer RED High Contrast  
1010008159



Dark smoked mirrored  
multilayer RED  
1010008107  
Clear mirrored multilayer  
RED High Contrast  
1010008202



Clear mirrored multilayer  
BLUE  
1010008112  
Clear mirrored multilayer  
BLUE High Contrast  
1010008205



**NEW** GT Light smoked mirrored  
multilayer BLUE  
1010008228      Light smoked mirrored  
multilayer BLUE  
1010008108  
Light smoked mirrored multi-  
layer BLUE High Contrast  
1010008160



Dark smoked mirrored  
multilayer BLUE  
1010008109



Clear mirrored  
SILVER  
1010008113



**NEW** GT Light smoked mirrored  
SILVER  
1010008230      Light smoked mirrored  
SILVER  
1010008110



Clear for RAIN  
Adhesive fog resistant lens  
(no pins)  
1010008103  
Clear for RAIN  
Adhesive fog resistant lens  
(no pins) High Contrast  
1010008157

# HIGH CONTRAST VISORS TECHNOLOGY

Our eyes work like an RGB sensor, and struggle to recognize the difference between: **blue/green** light and **red/green** light.

This new filter works by better isolating the three colors, increasing the sharpness. By blocking color wave intersections as they pass through the lens, “high contrast” (HC) technology is able to eliminate color confusion, so your brain recognizes true color, faster. HC technology optimizes color and increases clarity, enabling you to see the track with an unparalleled level of vibrancy.

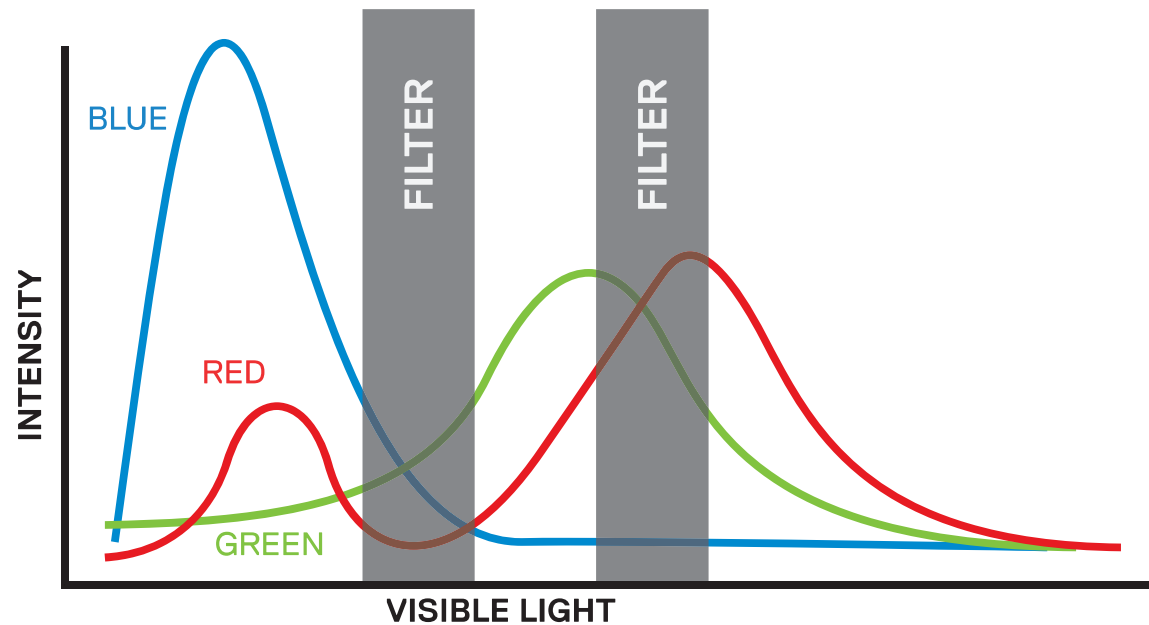
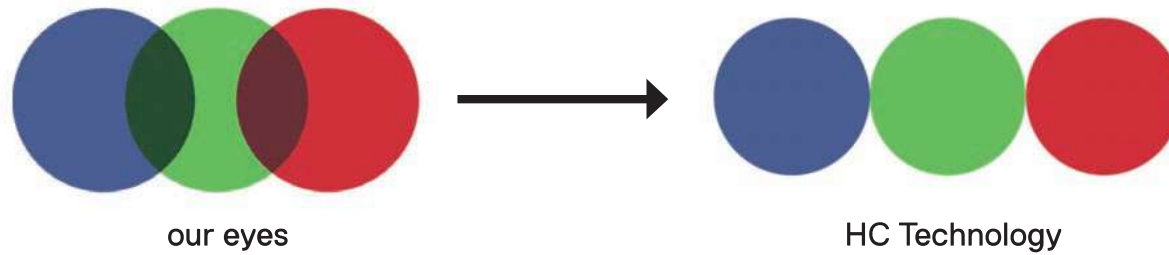

# VISOR FITTINGS



Pinlock® 120 fog resistant  
1010008086  
Adhesive fog resistant lens for  
1010008044



"Black only" visor kit  
(tear-off buttons + visor lever)  
1010003383  
"Clear only" visor kit  
(tear-off buttons + visor lever)  
1010003376

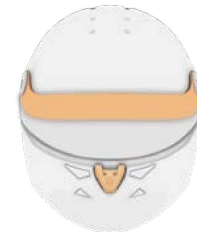

**NEW**

GT Sun Screen  
Supplied with locking cam cover  
1010008231



Locking cam - black  
1010003387  
Locking cam - clear  
1010003386



X-Stack Tear-off visors 4x3 4 mil  
1010003318  
X-Stack Tear-off visors 3x10 2 mil  
1010003319  
Speed-tabs for Tear-off 60 pcs  
1010003366



Visor mechanism + black screws  
1010008054

# SCOOPS



Scoop standard clear  
1010008093



Scoop flat clear  
1010008094



Head ventilation scoops  
(6 pcs)  
1010008100



TOP & SIDE forced air scoop clear  
1010008234 small connector Ø 23mm  
1010008153 large connector Ø 31mm



Forced air scoop clear  
1010008097 small connector Ø 23mm  
1010008096 large connector Ø 31mm



Flat forced air scoop clear  
1010008099 small connector Ø 23mm  
1010008098 large connector Ø 31mm

# SPOILERS



Top spoiler flat clear  
1010008164



Top spoiler clear  
1010008091



Chin ventilation scoops clear  
(2 pcs)  
1010008095



Chin spoiler clear  
1010008092



# EXTRA ITEMS



Helmet Skirt SFI 3.3  
10100011767



Top crown pad for eject system  
10100012418 7 mm  
10100012419 9 mm  
10100012420 15 mm



Eject system  
10100012417

# EXTRA ITEMS



Helmet racing bag  
1040004014



Helmet pouch  
1040001089



Visor pouch  
1040002017



Microfiber cloth  
1050001092



SCHUBERTH FHR CLIPS  
1010008133 Black



Schubert cheek pad logos  
1010003340

Flag cheek pad logos  
(available countries)  
1010008041



Schubert stickers  
1010008075



Schubert visor sticker  
1010008074



Rubber ring helmet holder  
1050001100

# RADIO HELMET KITS

Different radio helmet kit configurations are available upon request

Noise Reduction Earcup Speakers are not permitted for use in official FIA sanctioned events.



## INTEGRATED MIC

MALE PELTOR STD 4 PINS	RCA CONNECTOR	1010008136
	3.5 mm CONNECTOR	1010008139
	LEMO CONNECTOR	1010008147
MALE IMSA 4 PINS	RCA CONNECTOR	1010008196
	3.5 mm CONNECTOR	1010008197
	LEMO CONNECTOR	1010008198
MALE MRTC 5 PINS	RCA CONNECTOR	1010008138



## UNIVERSAL MIC

MALE PELTOR STD 4 PINS	RCA CONNECTOR	1010008144
	3.5 mm CONNECTOR	1010008145
	LEMO CONNECTOR	1010008146
MALE IMSA 4 PINS	RCA CONNECTOR	1010008199
	3.5 mm CONNECTOR	1010008200
	LEMO CONNECTOR	1010008201



## BOOM MIC

MALE PELTOR STD 4 PINS	RCA CONNECTOR	1010008137
	3.5 mm CONNECTOR	1010008140
	LEMO CONNECTOR	1010008233
MALE MRTC 5 PINS	3.5 mmCONNECTOR	1010008138

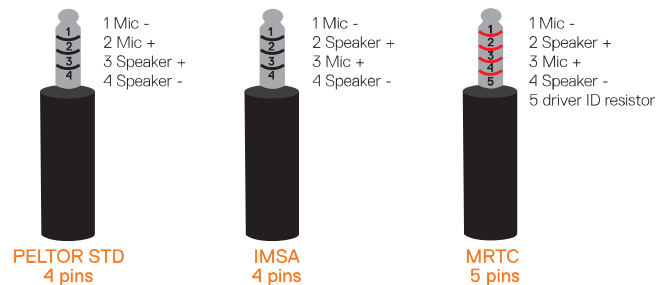

# EARPLUGS

Designed and manufactured by a leading hearing aid company in Italy, Ermes offer a comfortable alternative to custom earbuds. The different sized silicone tips ensure a tight fit and they even incorporate a cleanable wax filter guard just like hearing aids.

Utilizing micro audio components, the soft silicon shape positions the speaker at the end of the ear canal. The low profile design allows the earbuds to fit in line with the ear, reducing helmet contact. The optimization of space and components delivers professional quality sound for drivers who need the best possible communication.

## Include:

- Carry case,
- 3 sizes of silicone tips
- 6 replacement wax filters



MADE IN ITALY

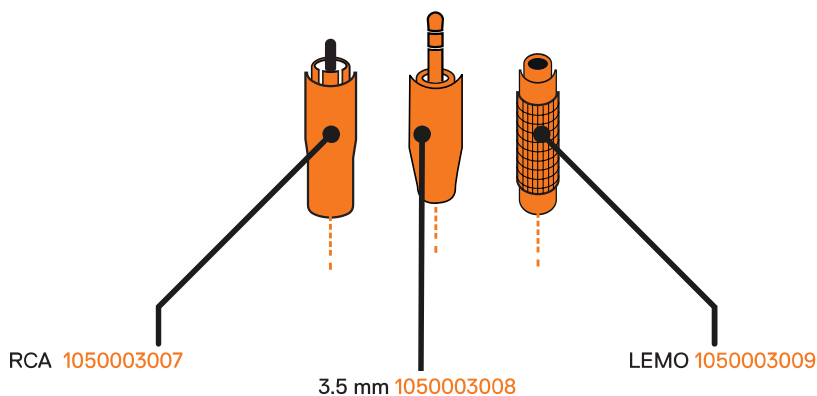

## TECHNOLOGY

The Ermes technology is the result of years of studies and tests that have made possible to apply the best receivers on the market.



## CLEAR COMMUNICATION

Constructed using the industries most advance technology and materials, Ermes offers a crystal clear communication.



## PROTECTION

Its ergonomic shape has been studied to guarantee incredible sound insulation and an excellent protection of the ear canal.



## COMFORT

Ermes are very small earbuds, designed specifically to be worn comfortably under the helmet without causing discomfort or pain.

**FOR RIDERS AND RACERS. FOR FIGHTERS, PROTECTORS AND WORKERS. FOR EVERY CHALLENGE. FOR EVERY GROUND. A PASSION AND A PROFESSION. A DAILY ADVENTURE. AND NO EXCUSES. WE SWEAT EVERY DETAIL, BECAUSE WE LOVE WHAT WE DO. THIS IS OUR THING. THIS IS SCHUBERTH. YOUR HEAD PROTECTION.**





**MAX VERSTAPPEN**  
F1 WORLD CHAMPION



**PROUD  
TO PROTECT YOU!**



**SCHUBERTH**  
PERFORMANCE



[WWW.SCHUBERTH.COM](http://WWW.SCHUBERTH.COM)



**SCHUBERTH**