



iWM5 Series Wall-Mount

Cooling capacity: 18 – 36 kBTU/h



Contents:

1 NOMENCLATURE.....	2
2 SPECIFICATIONS.....	3
3 DIMENSIONS.....	5
4 AIRFLOW DATA.....	6
5 WIRING DIAGRAMS.....	8



Features:

- Direct-drive, multi-speed motors allow air volume variation for heating / cooling.
 - Multi-speed ECM motor: M14 series
 - Multi-speed PSC motor: M13 series
- Thermoplastic drain pan with bottom primary and secondary drain connections.
- Built-in filter rack.
- Wall-hanging bracket provided.
- Front or bottom return available.
- Optional heating elements of 5kW, 8kW, and 10kW.
- All aluminum coil

1 Nomenclature

i	W	M	5	A	1	8	1				
1	2	3	4	5	6	7	8	9	10	11	

Legend		
No.	Code	Remarks
1	i	Brand: iAir
2	W	Discharge type: V: Vertical Air Handler W: Wall Mounted/ Vertical P: Pancake
3	M	Installation type: B: Multiple Position Installation M: Vertical Position Installation C: Cased (pancake) U: Uncased (pancake)
4	5	Motor type: 4: PSC Motor 5: ECM Motor
5	A	Future Use
6-7	18	Capacity: 18: 18 kBtu/h; 24: 24 kBtu/h; 30: 30 kBtu/h; 36: 36 kBtu/h; 42: 42 kBtu/h; 48: 48 kBtu/h; 60/61: 60 kBtu/h; Cabinet Size
8	1	Cabinet Version Number
9	Not used	
10	Not used	
11	Not used	
12	Not used	

2 Specifications

	iWM4A181	iWM4A241	iWM4A311	iWM4A361
NOMINAL RATING				
Cooling (BTU/h)	18,000	24,000	30,000	36,000
External Static Pressure(in.w.c)	0.8	0.8	0.8	0.8
ELECTRICAL DATA				
Voltage / Phase(60Hz)	208/230/1	208/230/1	208/230/1	208/230/1
Min. / Max. Voltage	187/253	187/253	187/253	187/253
Min. Circuit Amps	2.4	2.4	3.4	3.4
Max. Overcurrent Protection	15	15	15	15
FAN MOTOR				
Motor Type	ECM	ECM	ECM	ECM
Capacitor (uF)	\	\	\	\
Horsepower (HP)	1/3	1/3	1/2	1/2
Rated RPM	1050	1050	1050	1050
Full Load Amps (FLA)	1.9	1.9	2.6	2.6
FAN BLOWER				
Material	Metal	Metal	Metal	Metal
Type	Centrifugal	Centrifugal	Centrifugal	Centrifugal
Diameter(in.)	10-3/4	10-3/4	10-3/4	10-3/4
Height(in.)	6	6	8	8
EVAPORATOR COIL				
Type	Tube & Fin	Tube & Fin	Tube & Fin	Tube & Fin
Tube Material	Aluminum	Aluminum	Aluminum	Aluminum
Tube Size(in.)	9/32	9/32	9/32	9/32
SOUND POWER (dB)	50	54	54	54
REFRIGERANT CONNECTION SIZE				
Liquid Line Size (O.D.)	3/8	3/8	3/8	3/8
Suction Line Size (O.D.)	3/4	3/4	3/4	3/4

3 Dimensions

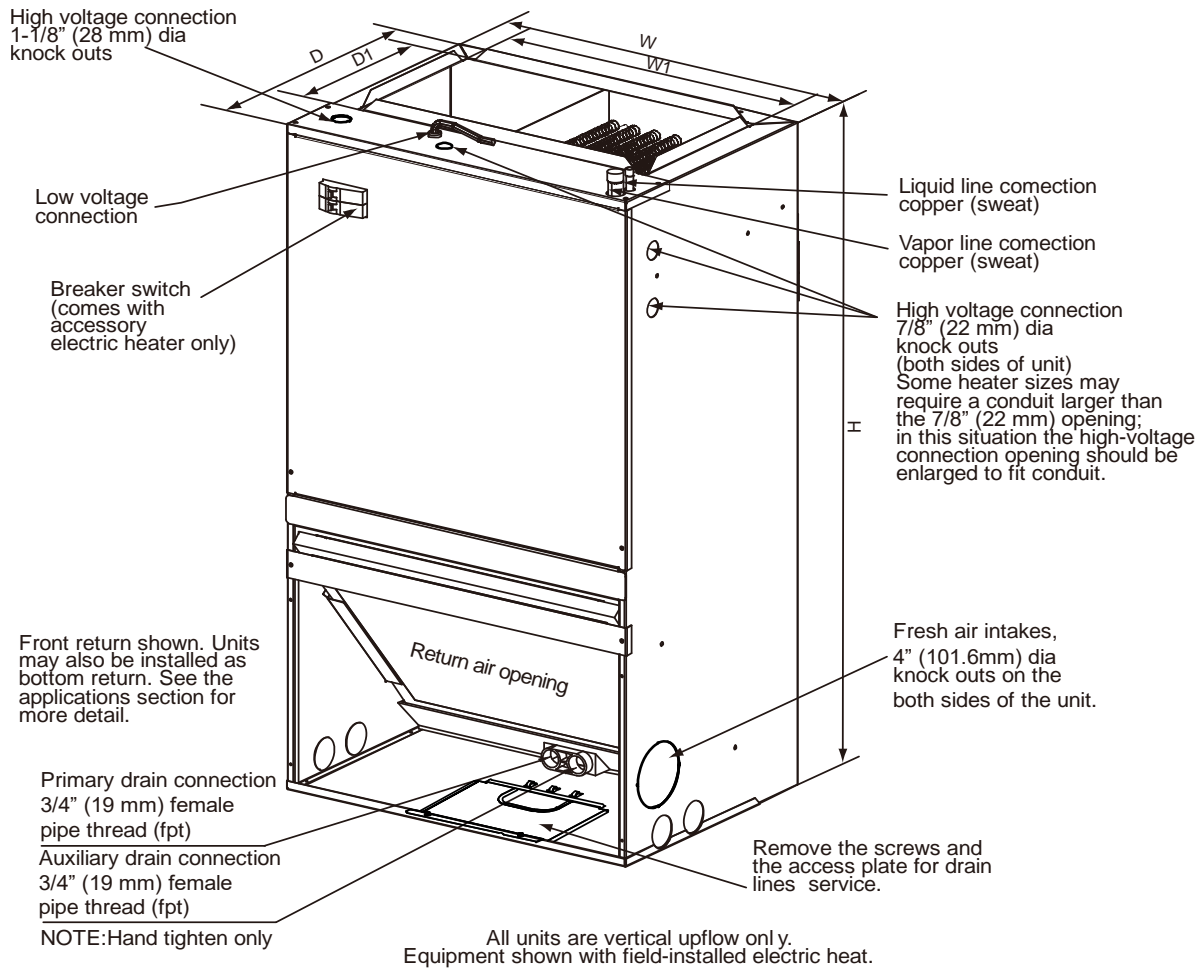

Model Size	Dimensions- In.					Unit Weight / Shipping Weight Lbs.
	Unit Height H	Unit Width W	Unit Width W1	Unit Depth D	Unit Depth D1	
ECM 18K/24K	36-1/2	20-1/2	17-2/5	15	9-1/2	79/ 95
ECM 30K/36K	39-1/2	22	18-4/5	19	9-1/2	97/ 119

4 Airflow Data

ECM Model	BLOW ER SPEEDS	EXTERNAL STATIC PRESSURE (in.w.c.)									
		0	0.1	0.18	0.2	0.3	0.4	0.5	0.6	0.7	0.8
18	Tap(5)	913	881	848	848	818	792	763	731	691	650
	Tap(4)	825	787	756	753	717	682	650	617	580	540
	Tap(3)	737	700	666	663	630	589	550	511	474	436
	Tap(2)-Factory	675	632	598	596	555	521	480	440	399	366
	Tap(1)	590	548	512	499	455	430	368	338	309	263
24	Tap(5)	913	881	848	848	818	792	763	731	691	650
	Tap(4)-Factory	825	787	756	753	717	682	650	617	580	540
	Tap(3)	737	700	666	663	630	589	550	511	474	436
	Tap(2)	675	632	598	596	555	521	480	440	399	366
	Tap(1)	590	548	512	499	455	430	368	338	309	263
30	Tap(5)	1362	1325	1280	1266	1238	1197	1159	1119	1080	1040
	Tap(4)	1282	1242	1195	1176	1151	1111	1071	1028	975	936
	Tap(3)	1267	1225	1178	1143	1120	1078	1036	993	942	897
	Tap(2)-Factory	1157	1111	1061	1052	1016	971	929	884	842	802
	Tap(1)	1077	1028	978	965	932	886	850	804	768	732
36	Tap(5)	1362	1325	1280	1266	1238	1197	1159	1119	1080	1040
	Tap(4)-Factory	1282	1242	1195	1176	1151	1111	1071	1028	975	936
	Tap(3)	1267	1225	1178	1143	1120	1078	1036	993	942	897
	Tap(2)	1157	1111	1061	1052	1016	971	929	884	842	802
	Tap(1)	1077	1028	978	965	932	886	850	804	768	732

--- Shaded boxes represent airflow outside the required 300-450 cfm/ton.

NOTES:

1. Airflow based upon dry coil at 230V with no electric heat and factory---approved filter. For MHVE airflow at 208V is approximately the same as 230V because the multi---tap ECM motor is a constant torque motor. The torque doesn't drop off at the speeds in which the motor operates.
2. Airflow is equivalent for front or bottom return configurations.

Filter Sizes	
Unit Size	Filter Size In.
18, 24	16x20x1
30, 36	20x20x1

5 Wiring Diagrams

SCHEMATIC DIAGRAM

SEE RATING PLATE FOR VOLTS&HERTZ
FIELD POWER WIRING

CAUTION:
 NOT SUITABLE FOR USE ON SYSTEMS EXCEEDING 150V TO GROUND
ATTENTION:
 NE CONVIENT PAS AUX INSTALLATIONS DE PLUS DE 150V ALA TERRE

W1 WHITE
 R RED
 C BROWN
 G GREEN

CAP AND SEAL THE UNUSED WIRE

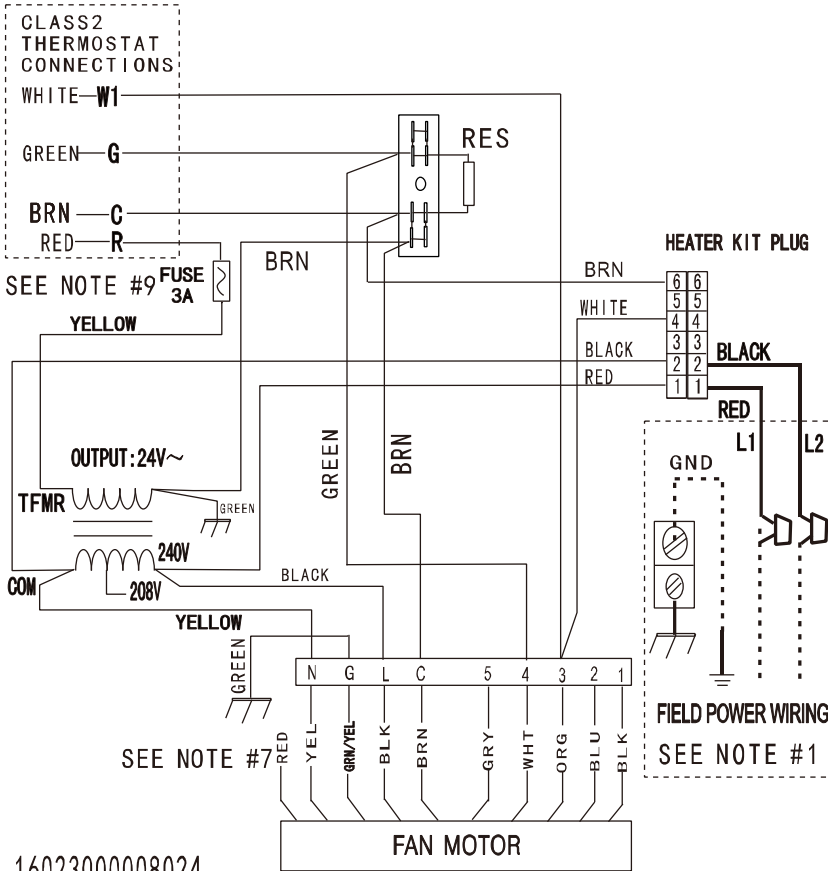

COMPONENT ARRANGEMENT

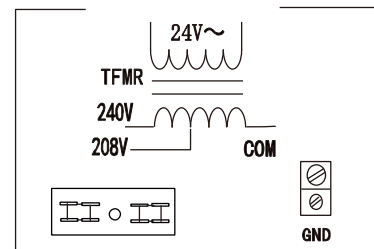

SPEED TAP SELECTION

- 1 LOW
- 2 MEDIUM LOW
- 3 MEDIUM
- 4 MEDIUM HIGH
- 5 HIGH

SEE NOTE #5, #6 & #8.

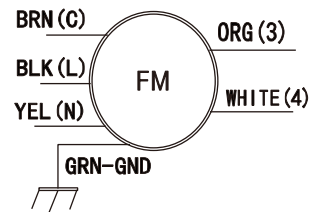

TFMR TRANSFORMER
 FM FAN MOTOR
 GND GROUND
 RES RESISTOR
 - - - - FIELD POWER WIRING

16023000008024

NOTES:

- 1: Use Copper Wire (75 Min) Only Between Disconnect Swith And Unit .
- 2: To Be Wired In Accordance With NEC And Local Codes.
- 3: If Any Of The Original Wire ,As Supplied, Must Be Replaced. Use The Same Or Equivalent Type Wire.
- 4: Connect R To R, G To G, Etc. See Outdoor Instruction For Details.
- 5: To Change Speed Tap, Move Green Wire To Desired Terminal 1 Through 5.
- 6: See Airflow Tables For Tap Usage.
- 7: Do Not Use Red Wire From Motor.
- 8: Taps 2 & 4 Have a 90s Delay Off, Taps 1, 3 & 5 are 30s.
- 9: The Fuse Model Is 32V/3A.

Fuse Manufacturer: Littelfuse, fuse part number: 0257003.



Add.: 8105 Anderson Road, Tampa Florida 33634

833-305-4247

iAir-USa.com

Note: Product specifications change from time to time as product improvements and developments are released and may vary from those in this document.

