



i4AH5 Series Indoor Unit/Air Handlers

Cooling capacity: 24 – 60 kBtu/h



Contents:

1 NOMENCLATURE.....	2
2 SPECIFICATIONS.....	3
3 DIMENSIONS.....	4
4 AIRFLOW DATA.....	5
5 WIRING DIAGRAMS.....	9
6 HEAT KIT DATA.....	11



Features:

- Available for cooling and heat pump applications.
- Multi-speed ECM blower motor.
- All-aluminum tubes & fins.
- Common Factory-sealed cabinet certified to achieve 2% or less leakage rate at 1.0 inch water column.
- Multi-position Installation.
- Horizontal and vertical condensate drain pans standard;
- Blower and coil easy slide out for ease of maintenance.
- Field Installed heater kits are optional: 5/7.5/10/15/20kW.
- AHRI Listed & ETL Certified.

1 Nomenclature

i	4	A	H	5	E	2	4	E		
1	2	3	4	5	6	7	8	9	10-	14

Legend		
No.	Code	Remarks
1	i	Brand: iAir
2	4	Type: 4: Air Handler 5: Wall Mounted 6: Pancake
3	A	Installation type: A: Multiple Position Installation V: Vertical Position Installation C: Cased (pancake) U: Uncased (pancake)
4	H	Refrigerant Type: H: r-410a
5	5	Motor Type 4: PSC 5: ECM
6	Not used	Future Use
7-8	18	Capacity: 18: 18 kBtu/h; 24: 24 kBtu/h; 30: 30 kBtu/h; 36: 36 kBtu/h; 42: 42 kBtu/h; 48: 48 kBtu/h; 60/61: 60 kBtu/h; Cabinet Size
9	E	Power supply type: E: 1-Phase; F: 3- Phase
10-14	Not used	Future Use

2 Specifications

	i4AH5E24E1B00A	i4AH5E36E1B00A	i4AH5E60E1B00A	i4AH5E61E1B00A
NOMINAL RATING				
Cooling (BTU/h)	24,000	36,000	60,000	60,000
External Static Pressure(in.w.c)	0.8	0.7	0.8	0.8
ELECTRICAL DATA				
Voltage / Phase(60Hz)	208/230/1	208/230/1	208/230/1	208/230/1
Min. / Max. Voltage	187/253	187/253	187/253	187/253
Min. Circuit Amps	3.3	3.8	5.7	5.7
Max. Overcurrent Protection	15	15	15	15
FAN MOTOR				
Motor Type	ECM	ECM	ECM	ECM
Capacitor (uF)	/	/	/	/
Horsepower (HP)	1/3	1/2	3/4	3/4
Rated RPM	1050	1050	1050	1050
Full Load Amps (FLA)	2.6	3.0	4.5	4.5
FAN BLOWER				
Material	Metal	Metal	Metal	Metal
Type	Centrifugal	Centrifugal	Centrifugal	Centrifugal
Diameter(in.)	10-5/8	13	13	13
Height(in.)	8-1/8	10-5/8	10-5/8	10-5/8
EVAPORATOR COIL				
Type	Tube & Fin	Tube & Fin	Tube & Fin	Tube & Fin
Tube Material	Aluminum	Aluminum	Aluminum	Aluminum
Tube Size(in.)	9/32	9/32	9/32	9/32
REFRIGERANT CONNECTION SIZE				
Liquid Line Size (O.D.)	3/8	3/8	3/8	3/8
Suction Line Size (O.D.)	3/4	3/4	7/8	7/8

3 Dimensions

NOTE: 25" CLEARANCE IS REQUIRED IN THE FRONT OF THE UNIT FOR FILTER AND COIL MAINTENANCE.

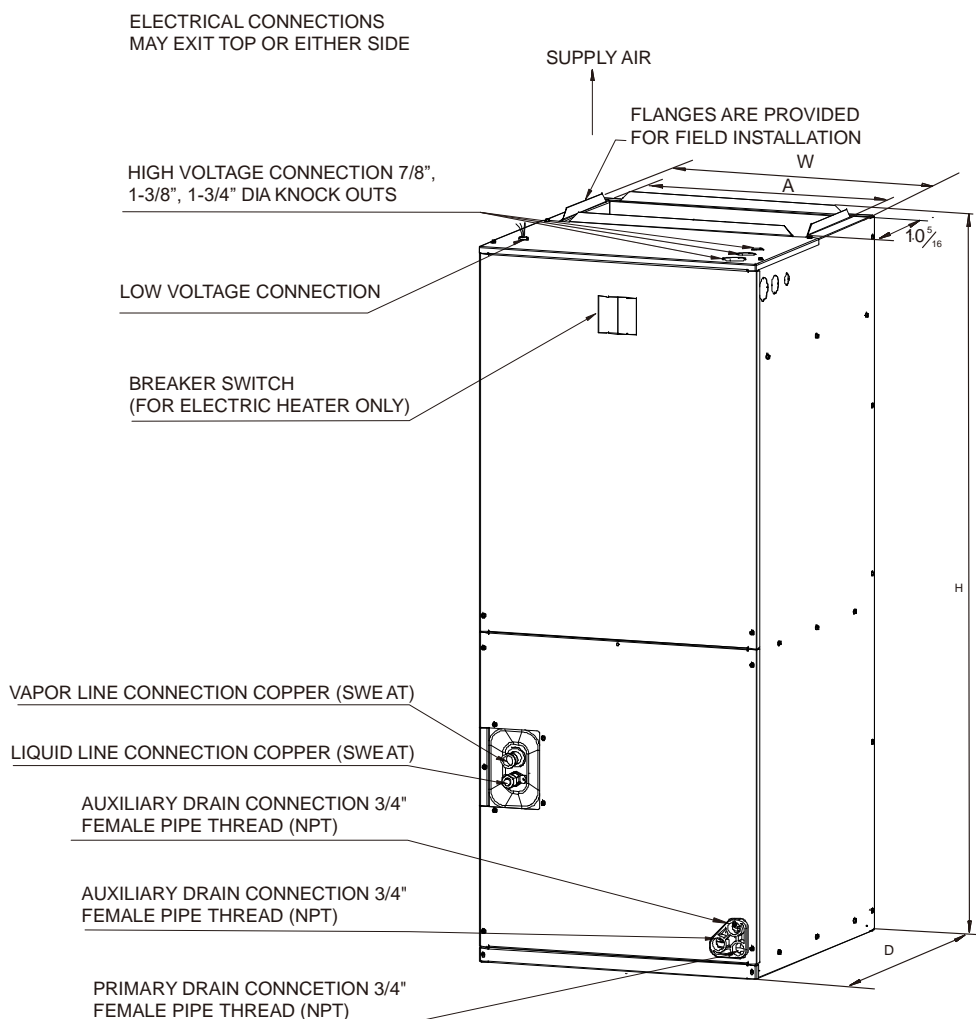

UPFLOW UNIT SHOWN;
UNIT MAY BE INSTALLED UPFLOW, DOWNFLOW,
HORIZONTAL RIGHT OR LEFT AIR SUPPLY.

	i4AH5E24E1B00A	i4AH5E36E1B00A	i4AH5E60E1B00A	i4AH5E61E1B00A
UNIT DIMENSION AND WEIGHTS				
Height(in.)	41-3/8	46-1/2	54-1/2	54-1/2
Width(in.)	18-1/8	19-5/8	22	22
Depth(in.)	20-1/2	21-5/8	24	24
Weight(lbs.)	101	125	159	161

4 Airflow Data

Air Handler Model	Outdoor Unit Size(Tons)	Motor Speed		CFM Wet Coil without filter and Electric Heat									
				External Static Pressure-Inches W.C.[kPa]									
				0[0]	0.1[.025]	0.2[.050]	0.3[.075]	0.4[0.100]	0.5[0.125]	0.6[0.150]	0.7[0.175]	0.8[0.200]	
24	1.5	1	SCFM	590	544	511	447	404	345	311	273	239	
			Power/W	49	57	64	70	75	82	91	97	102	
			Current/A	0.77	0.81	0.84	0.87	0.91	0.94	0.99	1.02	1.11	
		2	SCFM	681	633	591	535	490	446	388	354	313	
			Power/W	63	69	77	83	90	96	103	111	118	
			Current/A	0.84	0.87	0.93	0.96	0.99	1.03	1.07	1.13	1.16	
		3 (Recom mended)	SCFM	788	736	687	648	597	558	511	473	429	
			Power/W	86	91	100	108	114	121	128	133	142	
			Current/A	0.95	0.99	1.11	1.14	1.18	1.21	1.26	1.31	1.37	
		4 (Factory Default)	SCFM	883	842	796	758	717	681	642	599	524	
			Power/W	121	128	135	144	151	159	165	173	181	
			Current/A	1.21	1.28	1.32	1.38	1.43	1.47	1.54	1.59	1.64	
		5	SCFM	1103	1073	1036	998	967	934	896	855	814	
			Power/W	233	241	249	258	265	275	281	286	291	
			Current/A	1.97	2.03	2.09	2.16	2.22	2.29	2.34	2.37	2.41	
24	2	1	SCFM	590	544	511	447	404	345	311	273	239	
			Power/W	49	57	64	70	75	82	91	97	102	
			Current/A	0.77	0.81	0.84	0.87	0.91	0.94	0.99	1.02	1.11	
		2	SCFM	681	633	591	535	490	446	388	354	313	
			Power/W	63	69	77	83	90	96	103	111	118	
			Current/A	0.84	0.87	0.93	0.96	0.99	1.03	1.07	1.13	1.16	
		3	SCFM	788	736	687	648	597	558	511	473	429	
			Power/W	86	91	100	108	114	121	128	133	142	
			Current/A	0.95	0.99	1.11	1.14	1.18	1.21	1.26	1.31	1.37	
		4 (Factory Default)	SCFM	883	842	796	758	717	681	642	599	524	
			Power/W	121	128	135	144	151	159	165	173	181	
			Current/A	1.21	1.28	1.32	1.38	1.43	1.47	1.54	1.59	1.64	
		5	SCFM	1103	1073	1036	998	967	934	896	855	814	
			Power/W	233	241	249	258	265	275	281	286	291	
			Current/A	1.97	2.03	2.09	2.16	2.22	2.29	2.34	2.37	2.41	
36	2.5	1	SCFM	898	752	603	511	405	360	301	259	203	
			Power/W	78	72	65	60	54	48	41	38	36	
			Current/A	0.68	0.64	0.59	0.52	0.46	0.42	0.36	0.29	0.28	
		2	SCFM	1026	902	810	694	630	544	490	409	366	
			Power/W	109	99	106	111	120	126	135	140	148	
			Current/A	0.94	0.86	0.91	0.95	1.03	1.07	1.14	1.18	1.24	
		3	SCFM	1161	1114	1052	992	893	825	768	694	646	
			Power/W	148	158	164	175	187	193	203	209	219	
			Current/A	1.26	1.34	1.39	1.48	1.57	1.61	1.69	1.73	1.81	

36	2.5	4 (Recom mended)	SCFM	1287	1244	1186	1142	1078	969	914	892	893		
			Power/W	194	205	211	221	233	241	252	253	253		
			Current/A	1.62	1.69	1.75	1.83	1.93	1.98	2.07	2.08	2.11		
		5 (Factory Default)	SCFM	1491	1442	1396	1348	1302	1243	1150	1088	1029		
			Power/W	290	298	307	318	325	337	351	362	367		
			Current/A	2.35	2.42	2.49	2.58	2.64	2.73	2.83	2.92	2.96		
36	3	1	SCFM	898	752	603	511	405	360	301	259	203		
			Power/W	78	72	65	60	54	48	41	38	36		
			Current/A	0.68	0.64	0.59	0.52	0.46	0.42	0.36	0.29	0.28		
		2	SCFM	1026	902	810	694	630	544	490	409	366		
			Power/W	109	99	106	111	120	126	135	140	148		
			Current/A	0.94	0.86	0.91	0.95	1.03	1.07	1.14	1.18	1.24		
		3	SCFM	1161	1114	1052	992	893	825	768	694	646		
			Power/W	148	158	164	175	187	193	203	209	219		
			Current/A	1.26	1.34	1.39	1.48	1.57	1.61	1.69	1.73	1.81		
		4	SCFM	1287	1244	1186	1142	1078	969	914	892	893		
			Power/W	194	205	211	221	233	241	252	253	253		
			Current/A	1.62	1.69	1.75	1.83	1.93	1.98	2.07	2.08	2.11		
		5 (Factory Default)	SCFM	1491	1442	1396	1348	1302	1243	1150	1088	1029		
			Power/W	290	298	307	318	325	337	351	362	367		
			Current/A	2.35	2.42	2.49	2.58	2.64	2.73	2.83	2.92	2.96		
		60	3.5	1	SCFM	1344	1284	1226	1151	1076	946	904	893	869
					Power/W	143	151	159	168	177	191	197	195	194
					Current/A	1.23	1.26	1.33	1.41	1.5	1.61	1.63	1.61	1.62
2	SCFM			1531	1477	1418	1366	1299	1239	1138	1064	1001		
	Power/W			200	211	222	231	239	250	266	277	291		
	Current/A			1.73	1.74	1.81	1.89	2.02	2.14	2.22	2.31	2.38		
3 (Recom mended)	SCFM			1647	1592	1538	1490	1436	1378	1315	1215	1140		
	Power/W			244	254	263	273	283	300	305	325	336		
	Current/A			2.03	2.11	2.14	2.19	2.31	2.38	2.53	2.64	2.72		
4 (Factory Default)	SCFM			1875	1822	1774	1729	1677	1629	1581	1533	1473		
	Power/W			340	353	365	375	388	399	412	423	437		
	Current/A			2.73	2.79	2.86	3.02	3.12	3.21	3.29	2.38	3.51		
5	SCFM			2021	1967	1924	1879	1828	1785	1742	1694	1641		
	Power/W			409	416	429	447	461	471	487	500	513		
	Current/A			3.21	3.29	3.38	3.52	3.61	3.73	3.76	3.86	4.04		

60	4	1	SCFM	1344	1284	1226	1151	1076	946	904	893	869
			Power/W	143	151	159	168	177	191	197	195	194
			Current/A	1.23	1.26	1.33	1.41	1.5	1.61	1.63	1.61	1.62
		2	SCFM	1531	1477	1418	1366	1299	1239	1138	1064	1001
			Power/W	200	211	222	231	239	250	266	277	291
			Current/A	1.73	1.74	1.81	1.89	2.02	2.14	2.22	2.31	2.38
		3 (Recommended)	SCFM	1647	1592	1538	1490	1436	1378	1315	1215	1140
			Power/W	244	254	263	273	283	300	305	325	336
			Current/A	2.03	2.11	2.14	2.19	2.31	2.38	2.53	2.64	2.72
		4 (Factory Default)	SCFM	1875	1822	1774	1729	1677	1629	1581	1533	1473
			Power/W	340	353	365	375	388	399	412	423	437
			Current/A	2.73	2.79	2.86	3.02	3.12	3.21	3.29	2.38	3.51
5	SCFM	2021	1967	1924	1879	1828	1785	1742	1694	1641		
	Power/W	409	416	429	447	461	471	487	500	513		
	Current/A	3.21	3.29	3.38	3.52	3.61	3.73	3.76	3.86	4.04		
60	5	1	SCFM	1344	1284	1226	1151	1076	946	904	893	869
			Power/W	143	151	159	168	177	191	197	195	194
			Current/A	1.23	1.26	1.33	1.41	1.5	1.61	1.63	1.61	1.62
		2	SCFM	1531	1477	1418	1366	1299	1239	1138	1064	1001
			Power/W	200	211	222	231	239	250	266	277	291
			Current/A	1.73	1.74	1.81	1.89	2.02	2.14	2.22	2.31	2.38
		3	SCFM	1647	1592	1538	1490	1436	1378	1315	1215	1140
			Power/W	244	254	263	273	283	300	305	325	336
			Current/A	2.03	2.11	2.14	2.19	2.31	2.38	2.53	2.64	2.72
		4 (Factory Default)	SCFM	1875	1822	1774	1729	1677	1629	1581	1533	1473
			Power/W	340	353	365	375	388	399	412	423	437
			Current/A	2.73	2.79	2.86	3	3.12	3.21	3.29	2.38	3.51
5	SCFM	2021	1967	1924	1879	1828	1785	1742	1694	1641		
	Power/W	409	416	429	447	461	471	487	500	513		
	Current/A	3.21	3.29	3.38	3.52	3.61	3.73	3.76	3.86	4.04		
61	6	1	SCFM	1348	1280	1227	1180	1130	1042	933	871	825
			Power/W	157	165	176	187	196	206	225	233	245
			Current/A	1.34	1.4	1.49	1.58	1.64	1.73	1.88	1.94	2.03
		2	SCFM	1491	1439	1380	1334	1285	1246	1180	1047	988
			Power/W	205	217	226	238	250	259	269	292	300
			Current/A	1.71	1.81	1.88	1.97	2.06	2.14	2.21	2.39	2.45
		3	SCFM	1677	1633	1586	1543	1499	1449	1409	1370	1281
			Power/W	281	297	311	325	338	346	358	370	386
			Current/A	2.3	2.41	2.52	2.63	2.73	2.79	2.88	2.98	3.09
		4 (Factory Default)	SCFM	1881	1843	1800	1754	1708	1666	1626	1590	1558
			Power/W	391	407	423	438	449	462	474	487	498
			Current/A	3.12	3.25	3.36	3.47	3.56	3.66	3.75	2.84	3.93
5	SCFM	2029	1988	1947	1900	1858	1815	1771	1716	1671		
	Power/W	426	482	498	514	528	541	553	565	572		

i4AH5 Series



			Current/A	3.67	3.8	3.92	4.03	4.13	4.24	4.33	4.41	4.47
--	--	--	-----------	------	-----	------	------	------	------	------	------	------

--- Shaded boxes represent airflow outside the required 300-450 cfm/ton, which are not recommended.

NOTES: Airflow based upon cooling performance at 230V with no electric heat and no filter. Airflow at 208V is approximately the same as 230V because the multi-tap ECM motor is a constant torque motor. The torque doesn't drop off at the speeds in which the motor operates.

The air distribution system has the greatest effect on airflow. The duct system is totally controlled by the contractor. For this reason, the contractor should use only industry-recognized procedures.

Heat pump systems require a specified airflow for electric heat operating. Each ton of cooling requires between 350 and 450 cubic feet of air per minute (CFM), or 400 CFM nominally.

Duct design and construction should be carefully done. System performance can be lowered dramatically through bad planning or workmanship.

Air supply diffusers must be selected and located carefully. They must be sized and positioned to deliver treated air along the perimeter of the space. If they are too small for their intended airflow, they become noisy. If they are not located properly, they cause drafts. Return air grilles must be properly sized to carry air back to the blower. If they are too small, they also cause noise. The installers should balance the air distribution system to ensure proper quiet airflow to all rooms in the home.

This ensures a comfortable living space.

An air velocity meter or airflow hood can be used to balance and verify branch and system airflow (CFM).

5 Wiring Diagrams

i4AH5E24E1B00A; i4AH5E36E1B00A; i4AH5E60E1B00A

SCHEMATIC DIAGRAM

SEE RATING PLATE FOR VOLTS&HERTZ

FIELD POWER WIRING

CAUTION:
NOT SUITABLE FOR USE ON SYSTEMS EXCEEDING 150V TO GROUND

ATTENTION:
NE CONVIENT PAS AUX INSTALLATIONS DE PLUS DE 150V ALA TERRE

HEATER KIT PLUG

SW1
ON 123
ON 123
ON 123
ACCORDING TO SETTING TABLE

OUTPUT: 24V~

TFMR
RED
RED

PLUG LIATE

FAN MOTOR

DIP SWITCH SW1 SETTINGS

MODEL	DIAL CODE	SPEED
/		3 MEDIUM
24K/60K		4 MEDIUM HIGH
36K		5 HIGH

SPEED TAPS

- 1 LOW
- 2 MEDIUM LOW
- 3 MEDIUM
- 4 MEDIUM HIGH
- 5 HIGH

SEE NOTE 6

	N	GND	L	C	5	4	3	2	1
FM WIRE CONFIG 1	YELLOW	Y/G	BLACK	BROWN	GRAY	WHITE	ORANGE	BLUE	BLACK
FM WIRE CONFIG 2	BLUE	GREEN	RED	WHITE	PINK	GRAY	BROWN	YELLOW	BLACK

NOTES:

- Use copper wire (75°C Min) only between disconnect switch and unit.
- To be wired in accordance with NEC and local codes.
- If any of the original wire, as supplied, must be replaced. Use the same or equivalent type wire.
- Connect R to R, G to G, etc. See outdoor instruction for details.
- To change speed tap, adjust dip switches (SW1).
- See airflow tables for airflow settings.

FM FAN MOTOR
TFMR TRANSFORMER
GND GROUND
----- OPTIONAL
..... FIELD POWER WIRING

Factory code	Date	Revision
16023000013093	Jul. 26, 2022	A

THE WIRING DIAGRAM SHOWN IS FOR REFERENCE ONLY, ACTUAL PRODUCT MAY VARY.

5 Wiring Diagrams

i4AH5E61E1B00A

SCHEMATIC DIAGRAM

SEE RATING PLATE FOR VOLT&HERTZ FIELD POWER WIRING

CAUTION
NOT SUITABLE FOR USE ON SYSTEMS EXCEEDING 150V TO GROUND.

ATTENTION:
NE CONVIENT PAS AUX INSTALLATIONS DE PLUS DE 150V A LA TERRE.

DeTAILED REFERENCE MANUAL INSTRUCTIONS

INDOOR MAIN BOARD

***THE FACTORY DEFAULT**

BLACK BLOCK IS BUTTON	Y1 OR G	Y1+Y2 OR W
ON 1 2	1	2
ON 1 2	1	3
* ON 1 2 61K	2	4
ON 1 2	3	5
ON 3	RESERVED	
* ON 3	Heat: Fan start	
ON 4	RESERVED	
* ON 4	NORMAL	

Switch ON Position: Color upper half to show switch position is UP. ON 1

Switch OFF Position: Color upper half to show switch position is DOWN. OFF 1

SPEED TAPS

LED4 indication description

POWER ON

NORMAL

T1: RETURN AIR TEMPERATURE SENSOR
T2: INDOOR COIL TEMPERATURE SENSOR

Factory code	Date	Revision
16023000013092	Jul. 26, 2022	A

THE WIRING DIAGRAM SHOWN IS FOR REFERENCE ONLY, ACTUAL PRODUCT MAY VARY.

NOTES:

- 1: If connected to the 1-Stage controller, please short the signals Y1 and Y2.
- 2: Use copper wire (75°C min) only between disconnect switch and unit .
- 3: To be wired in accordance with NEC and local codes.
- 4: If any of the original wire, as supplied, must be replaced. Use the same or equivalent type wire.
- 5: Connect R to R, G to G, Y1 to Y, etc. See outdoor instruction for details.
- 6: If some signal lines of CN4 and CN5 are not used, please Wrap them up separately with cap.
- 7: See airflow tables for airflow settings.
- 8: When need to change the transformer stage, remove the lead from "240V" terminal and then connect the lead to "208V" terminal.

6 Heater Kits

Model	Air Handler Capacity (kBTU/h)	Electric Heat(kW)	Min. Circuit Ampacity		Max. Fuse or Breaker (HACR) Ampacity		Minimum Heating Blower Speed					
			240V	208V	240V	208V	1	2	3	4	5	
i4AH5E24E1B00A	24											
EHK-05A(UL)		5	29	25.5	30	30	•	•	•	•	•	
EHK-08A(UL)		7.5	42	36.8	45	40	x	x	•	•	•	
EHK-10A(UL)		10	55	48.1	60	50	x	x	•	•	•	
i4AH5E36E1B00A	36											
EHK-05A(UL)		5	29.4	25.9	30	30	•	•	•	•	•	
EHK-08A(UL)		7.5	42.4	37.2	45	40	x	•	•	•	•	
EHK-10A(UL)		10	55.4	48.5	60	50	x	x	•	•	•	
EHK-15B(UL)		15	55.4/26.1	48.5/22.6	60/30	50/25	x	x	•	•	•	
EHK-20B(UL)	20	55.4/52.1	48.5/45.2	60/60	60/50	x	x	x	•	•		
i4AH5E60E1B00A / i4AH5E61E1B00A	60/61											
EHK-05A(UL)		5	31.8	28.3	35	30	x	x	•	•	•	
EHK-08A(UL)		7.5	44.8	39.6	45	40	x	x	•	•	•	
EHK-10A(UL)		10	57.8	50.9	60	60	x	x	•	•	•	
EHK-15B(UL)		15	57.8/26.1	50.9/22.6	60/30	60/25	x	x	•	•	•	
EHK-20B(UL)	20	57.8/52.1	50.9/45.2	60/60	60/50	x	x	x	•	•		

NOTE: HEATER MODEL NUMBER DIGITS "***" : A,B

Heat kit suitable for AHU 4-way position installation.

Ampacities for MCA and Fuse/breaker including the blower motor.

Heat pump systems require a specified airflow. Each ton of cooling requires between 350 and 450 cubic feet of air per minute (CFM), or 400 CFM nominally.

Electric Heater Kits

NO.	Kit	Description	Ref. Air Handler Use
1	EHK-05A(UL)	5kW Heat Strip	18/24//30/36/42/48/60
2	EHK-08A(UL)	7.5kW Heat Strip	18/24//30/36/42/48/60
3	EHK-10A(UL)	10kW Heat Strip	18/24//30/36/42/48/60
4	EHK-15B(UL)	15kW Heat Strip, double Breaker panel	30/36/42/48/60
5	EHK-20B(UL)	20kW Heat Strip, double Breaker panel	36/42/48/60

NOTE: HEATER MODEL NUMBER DIGITS "***" : A,B

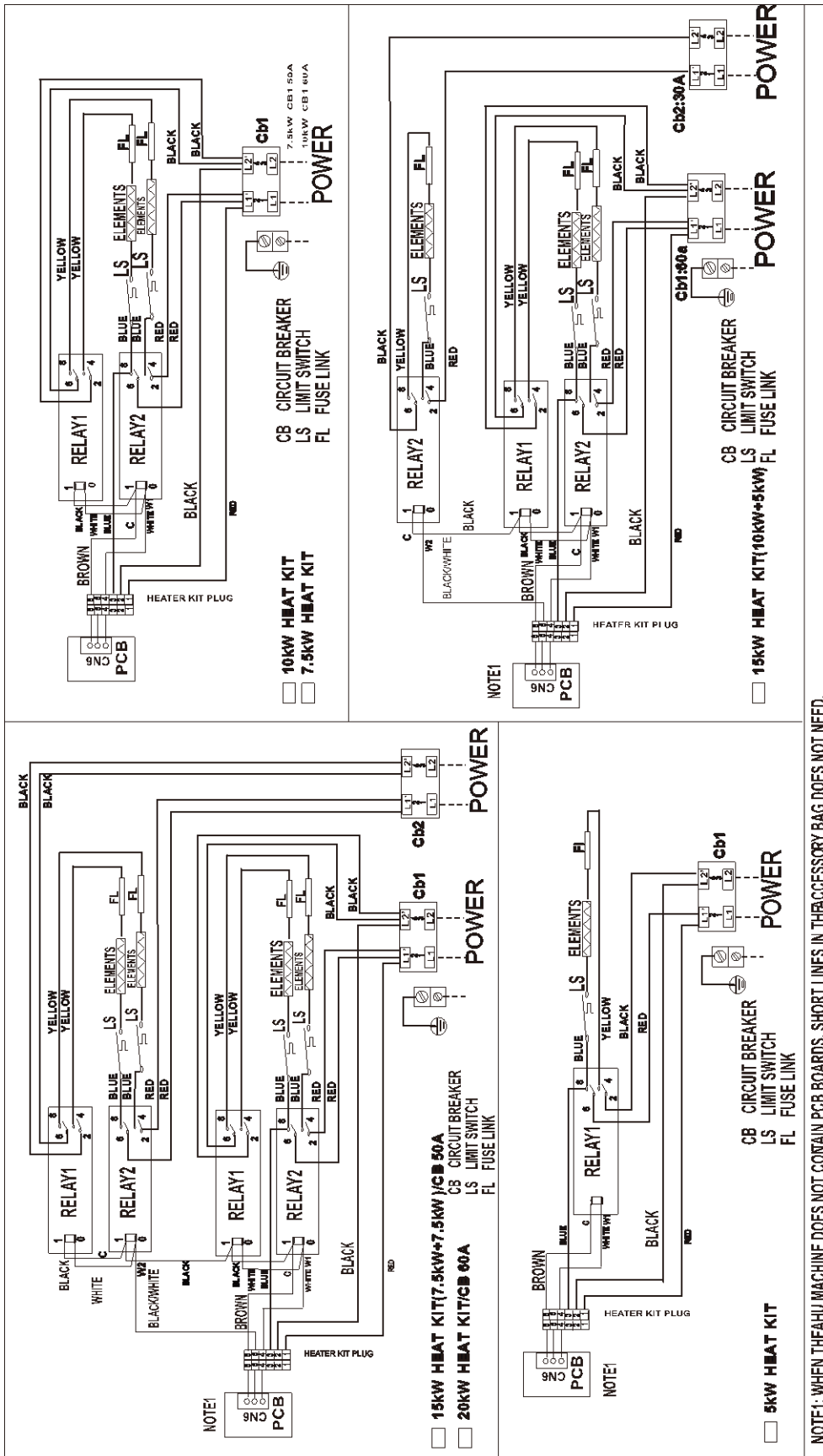

Address: 8105 Anderson Rd, Tampa, FL 33634

833-305-4247

iAir-USA.com

Note: Product specifications change from time to time as product improvements and developments are released and may vary from those in this document.

