

JOHN DEERE 600/700 SERIES 12 Row Folding Head G4 TOOLBAR MOUNT STALK STOMPER

 **CAUTION**

PLEASE REFER TO YOUR EQUIPMENT MANUFACTURER'S
OPERATORS MANUAL FOR PERTINENT SAFETY PRECAUTIONS

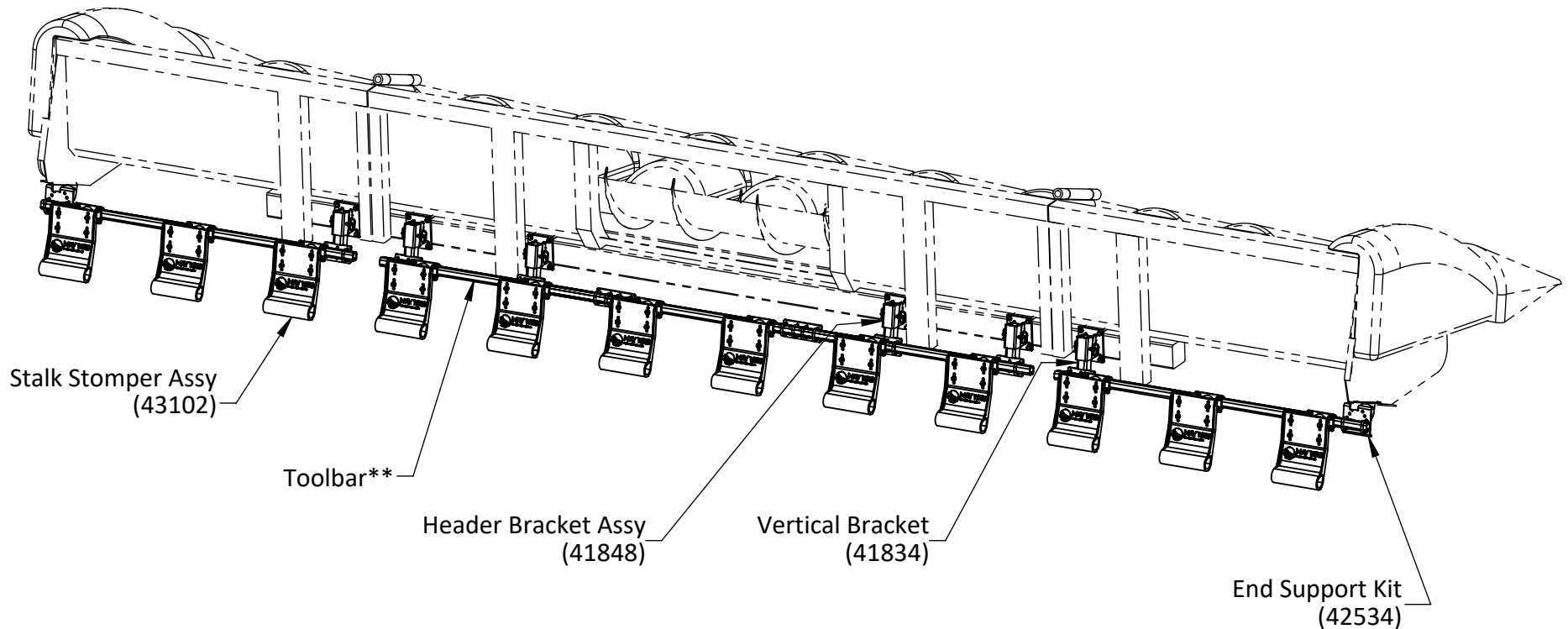

Notes:

- Illustration shown is for reference purposes only, locations of items may vary. Please refer to individual component parts listings for specific information.
 - Due to variation of implement configurations, row coverage under the feeder house may not be applicable.
- ** Toolbar is not included in all kits. If a kit without Toolbar was ordered, the customer is responsible for providing required Toolbar.



120 Eastgate Drive SE
Hutchinson, MN 55350

1-800-788-6483
1-320-587-2322
1-320-587-6112 (Fax)

WWW.MAYWES.COM

JOHN DEERE 600/700 SERIES 12 Row Folding Head G4 TOOLBAR MOUNT STALK STOMPER

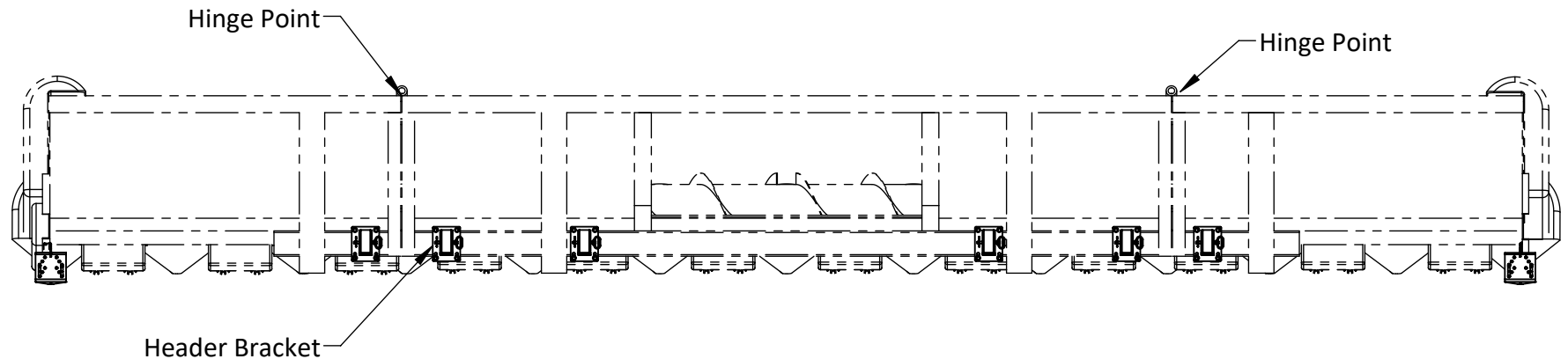

Installation Procedure:

- Park combine on level ground and lock the brakes.
- Raise the head and lock in the upright position.
- Mount the Header Brackets to the 5" x 5" (2011 and older) or 6" x 6" (2012 and newer) frame beam on the rear of the corn head using the straps, washers, bolts and nuts supplied. Mount two Header Brackets on each side of the head, positioning the brackets where needed while keeping as much distance between them as possible.

NOTE: Clearance holes may need to be drilled for the bolts at the top of the frame beam if sheet metal is present at determined mounting locations

- Mount a Header Bracket on each side of the Split.



120 Eastgate Drive SE
Hutchinson, MN 55350

1-800-788-6483
1-320-587-2322
1-320-587-6112 (Fax)

WWW.MAYWES.COM

JOHN DEERE 600/700 SERIES 12 Row Folding Head G4 TOOLBAR MOUNT STALK STOMPER

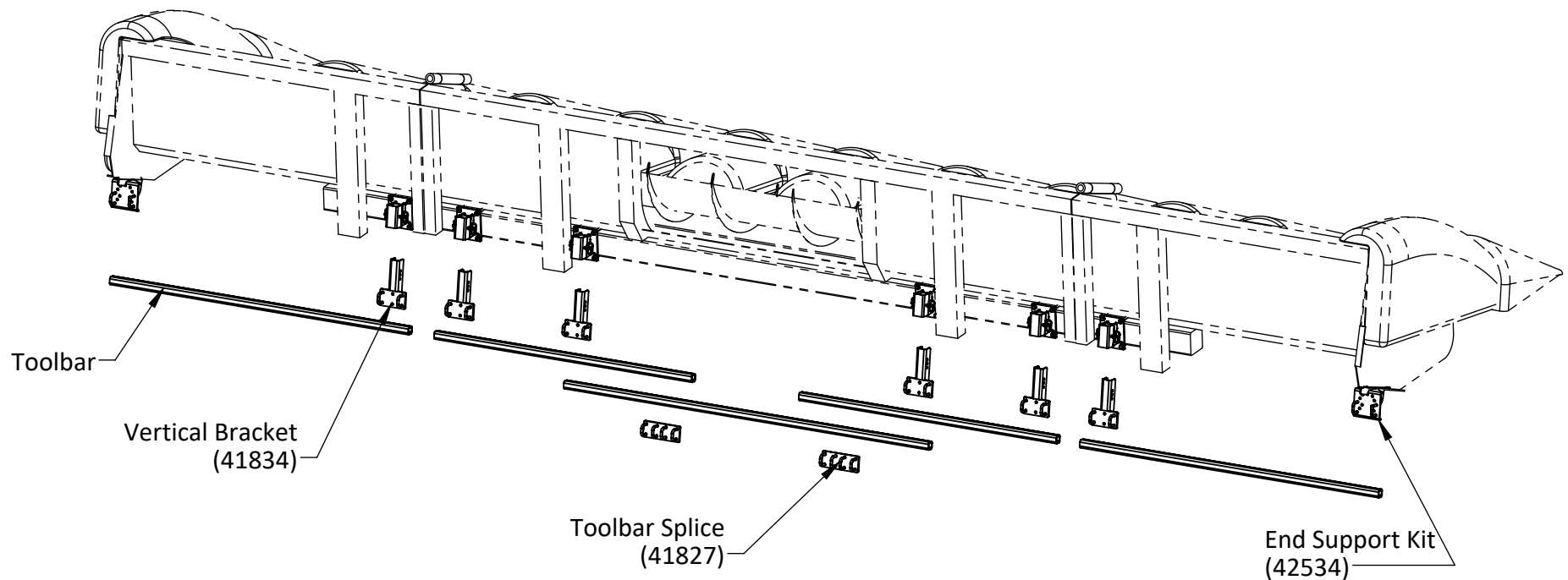

Installation Procedure:

- Install Vertical Brackets into Header Brackets and secure in place with Hitch Pins.
- Install toolbars to the Vertical Brackets using the 2" U-bolts provided with the kit.

Note: Toolbar is not included in all kits. If a kit without Toolbar was ordered, the customer is responsible for providing required Toolbar.

- Toolbars may need to be trimmed and connected with Splice Plates, depending on number of rows and row spacing.



120 Eastgate Drive SE
Hutchinson, MN 55350

1-800-788-6483
1-320-587-2322
1-320-587-6112 (Fax)

WWW.MAYWES.COM

JOHN DEERE 600/700 SERIES 12 Row Folding Head G4 TOOLBAR MOUNT STALK STOMPER

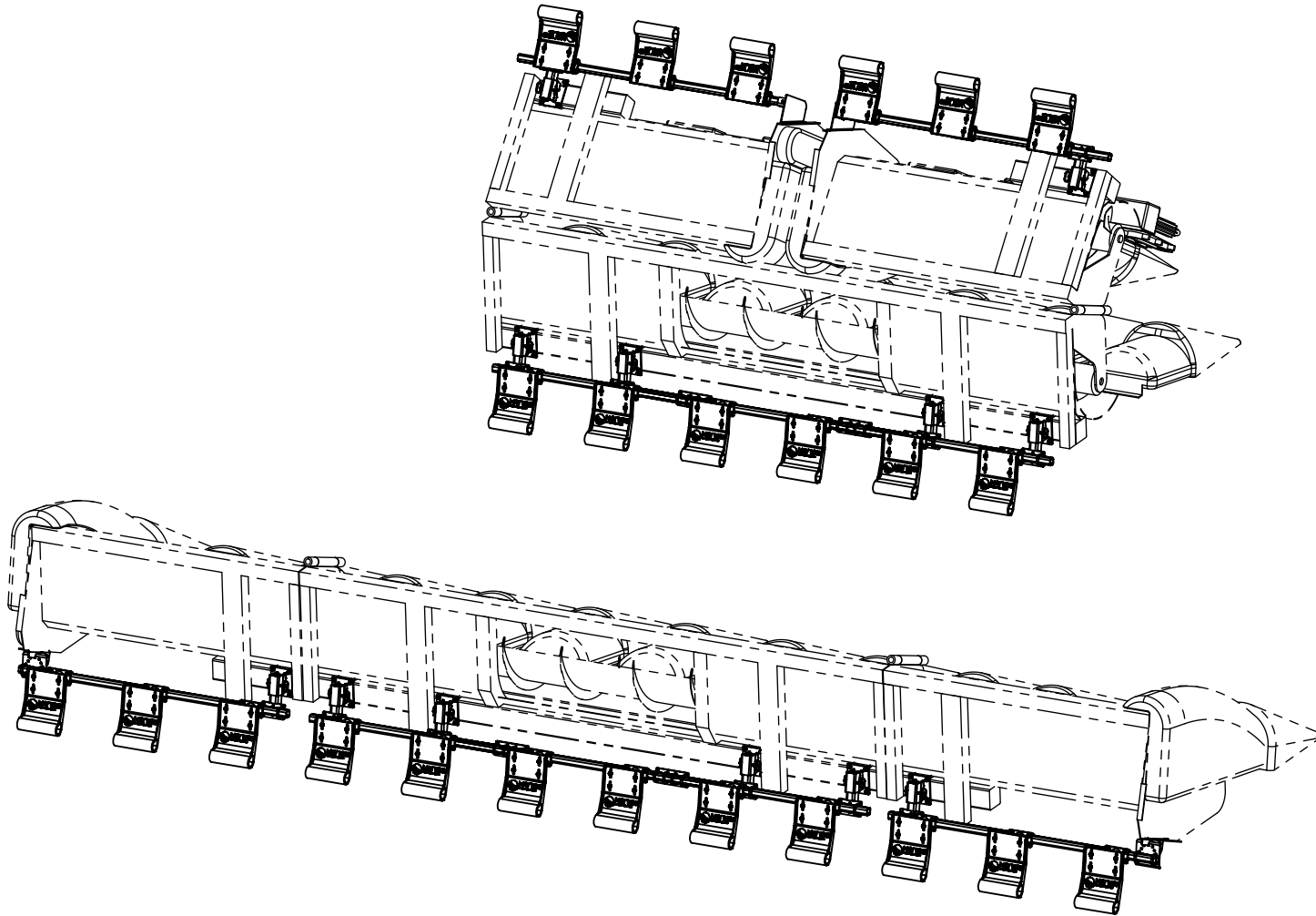

120 Eastgate Drive SE
Hutchinson, MN 55350

1-800-788-6483
1-320-587-2322
1-320-587-6112 (Fax)

WWW.MAYWES.COM

42534 END SUPPORT KIT Installation Instructions

Installation Procedure :

- Install the Left Outside Support Bracket (#43191) using supplied hardware to frame of the header as shown (See Figure 1).
- Secure toolbar to bracket using included u-bolts.
- position the tube flush or over hang the end support up to 1"
- Repeat steps to mount Right Outside Support Bracket (#43192) .

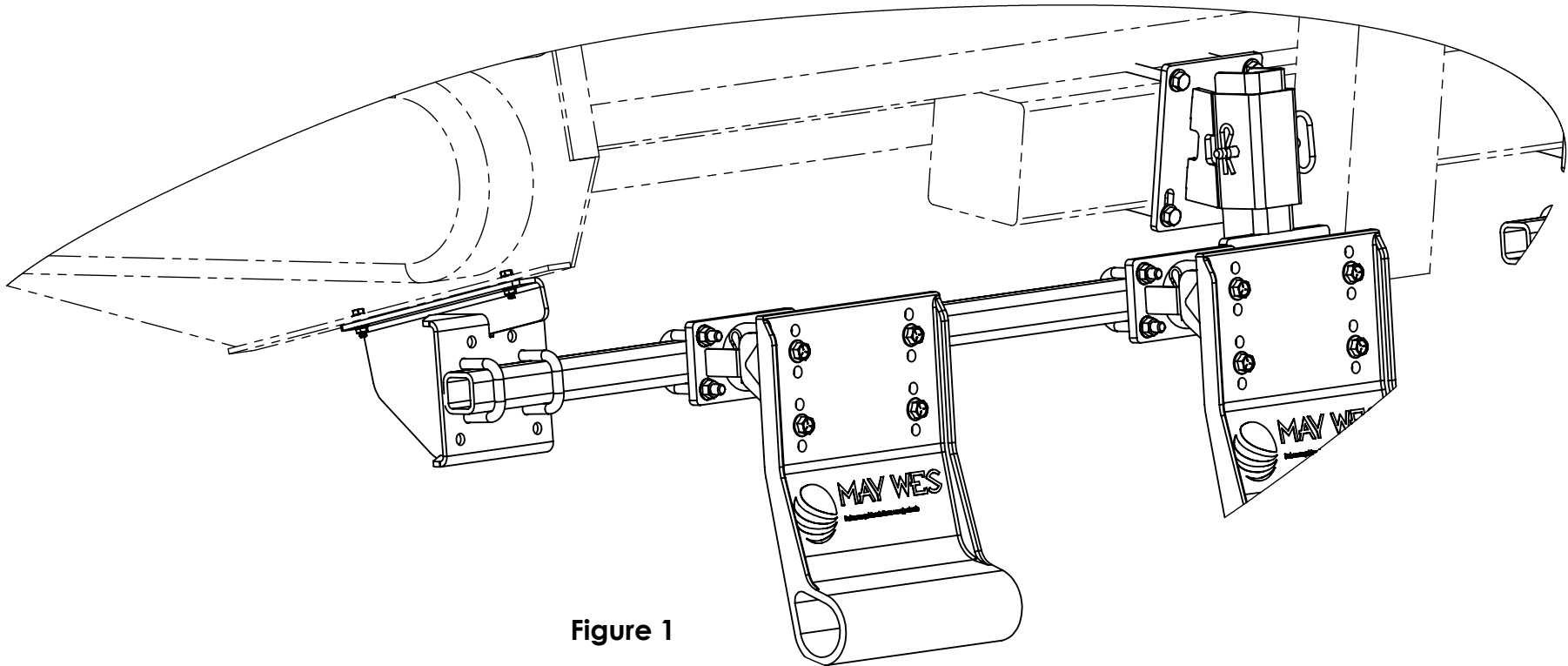
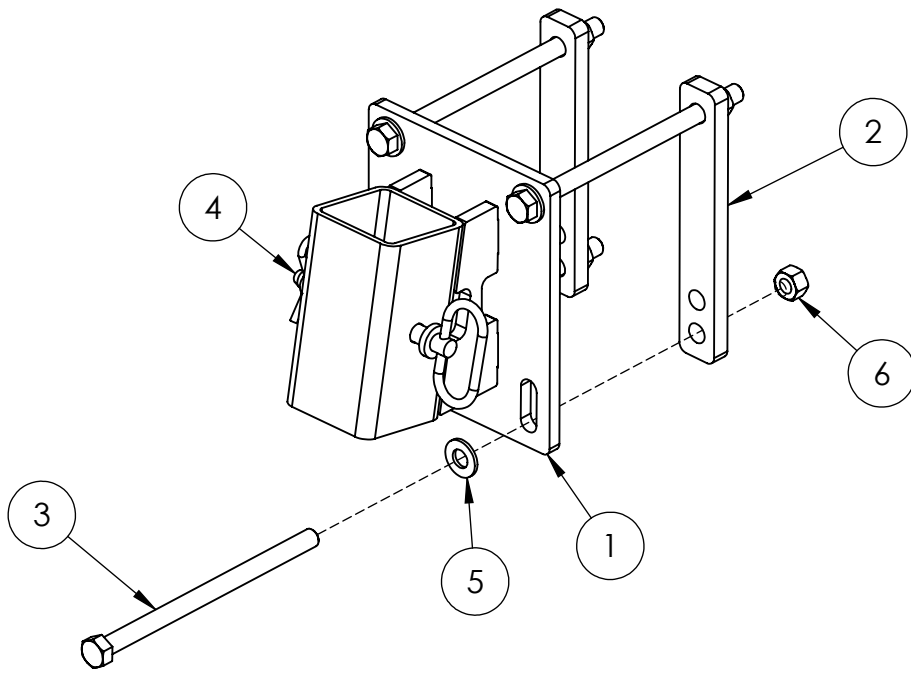

Figure 1

JOHN DEERE 600 SERIES TOOLBAR MOUNT STALK STOMPER ASSEMBLY INSTRUCTIONS / PARTS LISTING



41848
HEADER BRACKET ASSEMBLY

ITEM#	PART#	DESCRIPTION	QTY
1	41849	HEADER BRACKET	1
2	22362	STRAP, HEADER BRACKET	2
3	01000	BOLT, 1/2"-13 X 8" HEX	4
4	20433	HITCH PIN	1
5	00253	WASHER, 1/2" SAE FLAT	4
6	00216	NUT, 1/2" NC TOP LOCK	4

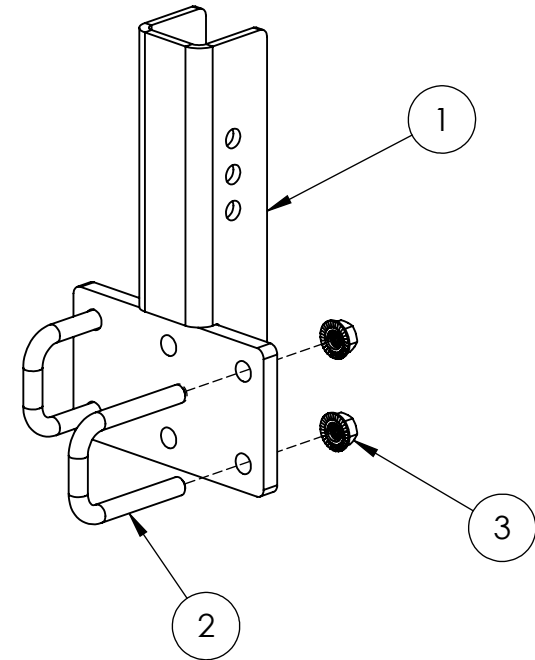

41834
Vertical Header Bracket

ITEM #	PART #	DESCRIPTION	QTY.
1	41783	VERTICAL BRACKET	1
2	00986	U-BOLT 1/2"-13	2
3	00730	Nut 1/2"-13 Serrated Flange	4

**JOHN DEERE 600/700 SERIES
TOOLBAR MOUNT STALK STOMPER
ASSEMBLY INSTRUCTIONS / PARTS LISTING**

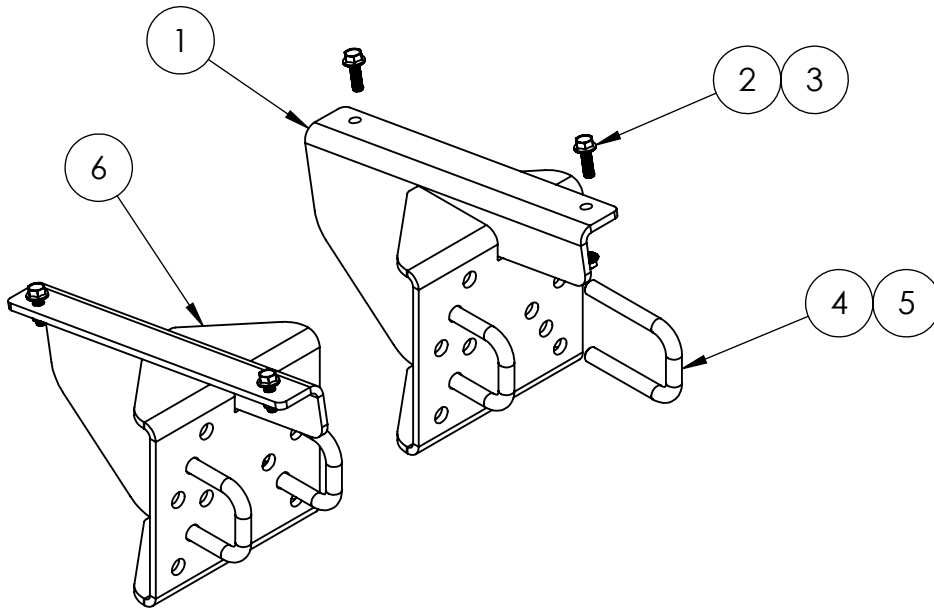

42534
End Support Kit

ITEM NO.	PART #	DESCRIPTION	QTY.
1	43192	BRACKET, END SUP RIGHT	1
2	00711	BOLT, 5/16"-18 X 1" FLANGE HEX	4
3	00714	NUT, 5/16"-18 FLANGE HEX	4
4	00986	U-BOLT 1/2"-13	4
5	00730	Nut 1/2"-13 Serrated Flange	8
6	43191	BRACKET, END SUP LEFT	1

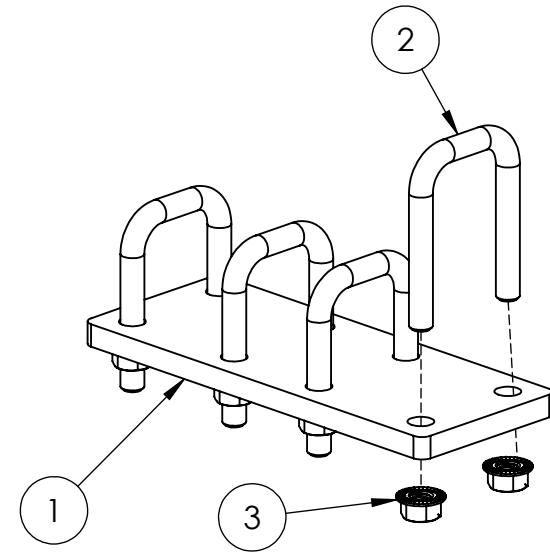

41827
Splice Bracket

ITEM #	PART #	DESCRIPTION	QTY.
1	22341	SPLICE PLATE	1
2	00986	U-BOLT 1/2"-13	4
3	00730	Nut 1/2"-13 Serrated Flange	8



120 Eastgate Drive SE
Hutchinson, MN 55350

1-800-788-6483
1-320-587-2322
1-320-587-6112 (Fax)

WWW.MAYWES.COM