

# American Changer



Models: AC107, AC110,  
AC111, AC115, and AC125

## Ticket Dispenser Series Installation, Operation, and Service Manual



*Changing the Industry<sup>SM</sup>*

### **! WARNING**

**Improper installation,  
adjustment, alteration,  
service, maintenance, or use  
of this machine can result in  
death, injury or property  
damage.**

#### **Installers & Service Technicians**

Read and understand the instructions  
detailed in this manual.

#### **Owners & Operators**

Keep this manual in a safe place to  
provide to any service technicians  
working on this machine.

American Changer

1400 N.W. 65th Place, Ft. Lauderdale, FL 33309

Tel (954) 917-3009 • Fax (954) 917-3079

[www.americanchanger.com](http://www.americanchanger.com) [www.hoffmanmint.com](http://www.hoffmanmint.com)



# Table of Contents

## **Section 1 – Product Overview**

1.1 – Machine Specifications.....	2
1.2 – Warranty Information.....	2
1.3 – Machine Safety.....	3

## **Section 2 – Setup & Installation**

2.1 – Setup.....	5
2.2 – Mounting Instructions.....	6

## **Section 3 – Operational Overview**

3.1 – Component Description.....	8
3.2 – Functional Description (AC107 & AC110).....	13
3.3 – Out-of-Service Conditions & Error Codes (AC107 & AC110).....	13
3.4 – Programming Menu (AC107 & AC110).....	15
3.5 – Remote Loading Software to the Flex-2 Board (AC107 & AC110).....	19
3.6 – Functional Description (AC111, AC115, & AC125).....	20
3.7 – Out-of-Service Conditions & Error Codes (AC111, AC115, & AC125).....	20
3.8 – Programming Menu (AC111, AC115, & AC125)	21

## **Section 4 – Maintenance**

4.1 – Ticket Dispenser Maintenance.....	25
4.2 – Banknote Validator Maintenance.....	26
4.3 – Coin Hopper Maintenance.....	30
4.4 – Warranty Terms and Conditions.....	31

**©2018 American Changer**

All rights reserved. No part of this work covered by copyrights herein may be reproduced or copied in any form or by means – graphic, electronic or mechanical, including photocopying, recording, taping or information storage and retrieval systems – without the written permission of American Changer

# Section 1 – Product Overview

## 1.1 – Machine Specifications

Operating Voltage (selectable by switch on power supply)	Set at 115VAC: 90 ~ 132VAC 4.0A Set at 230VAC: 180 ~ 264VAC 6.0A
Power Consumption	100W Max
Operating Temperature	41°F to 104°F / 5°C to 40°C
Interface to Ticket Dispenser	24VDC, 2.5 amps max

**\*Note:** Specifications stated herein may vary without notice. Capacities are approximations and may vary.

## 1.2 – Warranty Information

PLEASE REFERENCE SECTION 4.4 ON PAGES 31 AND 32 FOR AMERICAN CHANGER’S DETAILED LIMITED WARRANTY AND EXCLUSIVE REMEDIES. SOME HIGHLIGHTS FROM SAID SECTION ARE:

### Ticket Dispenser(s), Displays, and Logic Board(s)

These items are warranted for one year from date of purchase.

### Banknote Validator

This item is warranted for two years from the date of purchase.

### **COVERED**

- Manufacturers’ defects in workmanship or materials

### **NOT COVERED**

- Damage caused by shipping or physical abuse
- Misapplication
- Vandalism
- End users’ attempt, on their own, to repair components
- Cleaning and maintenance
- Power surges and lightning strikes

**A Return Material Authorization number (RMA #) must be obtained from American Changer Corporation before returning a unit for repair; warranty or otherwise. A copy of invoices must accompany any and all warranty work.**

## Section 1.3 – Machine Safety

### Your safety and the safety of others are very important to American Changer.

We have provided important safety messages in this manual and on your machine. Always read and obey all safety messages.



This is a safety alert symbol.

This symbol alerts you to potential hazards that can kill or hurt you and others. All safety messages will follow the safety alert symbol and either “DANGER”, “WARNING”, or “CAUTION”.

These words mean:



You can be killed or seriously injured if you don't immediately follow instructions



You can be killed or seriously injured if you don't follow instructions



You can be injured if you don't follow instructions

All safety messages will tell you what the potential hazard is, tell you how reduce the risk of injury, and tell you what can happen if the instructions are not followed.

Distributors, retailers, operators, and/or service people are to insure the following warning label is properly affixed on the ACC products to which you/they are using and/or servicing in order to help meet the applicable Proposition 65 requirements. For more information go to [www.P65Warnings.ca.gov](http://www.P65Warnings.ca.gov)



**WARNING:** Cancer and Reproductive Harm

[www.P65Warnings.ca.gov](http://www.P65Warnings.ca.gov)

## Important Safety Instructions

**DANGER:** To reduce the risks of severe injury secure the machine to a stable structure.



Severe Injury Hazard

This machine is to be secured to a stable structure.  
 Equipment will fall if not properly secured to a stable structure.  
 Failure to follow these instructions may result in death, injury, product damage, or property damage.

**WARNING:** To reduce the risk of electrical shock, disconnect all electrical power to the machine before servicing.



Electric Shock Hazard

Disconnect all electrical power to the machine before servicing.  
 Electric shock will occur while servicing the machine with electrical power applied to it.  
 Failure to follow these instructions may result in death, injury, product damage, or property damage.

**NOTICE:** For indoor use only.



For indoor use only.

Solo para usos en el interior.

Pour une utilisation en intérieur uniquement.



**NOTICE:** Ensure this machine is level when installed



Ensure this machine is level when installed.

Asegurarse que esta máquina esté nivelada cuando haya sido instalada.

S'assurer que la machine soit de niveau lorsqu'installée.

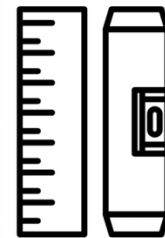

**SAVE THESE INSTRUCTIONS**

American Changer does not guarantee machines (products) or services to be 100% secure against criminal attempts. All machines (products) and services are to be used in accordance with business best practices and the owner's or operator's best judgement.

Installation, use, service and maintenance must be performed in accordance with applicable machine (product) manuals provided by American Changer and comply with any and all pertinent laws or regulations.

Inspect your machine (product), at a minimum annually, by a qualified service technician.

Dimensions and weights are reasonably close estimates. Specifications in this manual can vary without notice.

## Section 2 – Setup & Installation

### 2.1 – Setup

**NOTICE: THIS MODEL MACHINE IS FOR INDOOR USE ONLY.**

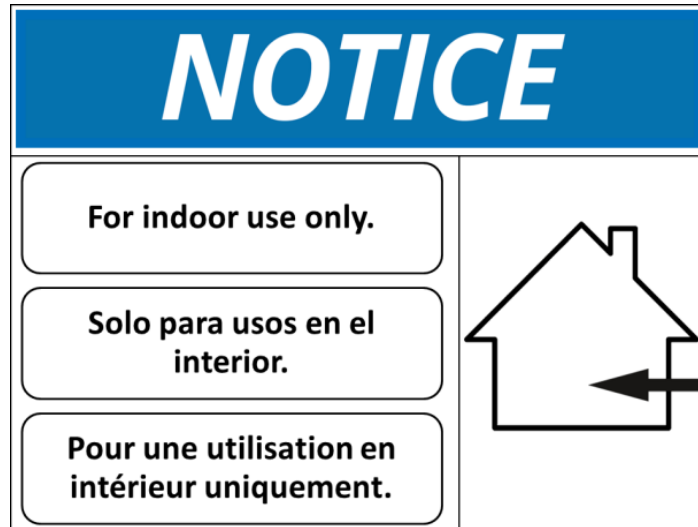

Inspect for any connectors or components that may have been dislodged during shipping. The lock and keys for your changer will be inside the manila envelope along with this manual and other pertinent information. To install the lock, insert the cylinder into the hole in the middle of the T-handle and push until it stops. Turn the key until you hear it “snap.” Turn the key counterclockwise ¼ turn and remove the keys.

**NOTE:** The only way to get a duplicate set of keys made is to save the tag that comes with the keys. The ID # begins with “AC” or “ACC” followed by digits.” If you purchased Medeco locks with your machine the ID will begin with “7RA” followed by digits.”

**CHECKING SHIPMENT:** Be sure to check the shipment against the Bill of Lading for shortages. Also, check for external damage to the packaging. Note any shortages and/or damage to the packaging on the Bill of Lading in the presence of the carrier and ask the carrier to initial on the Bill of Lading accordingly. Immediately report any shortages or damage to the packaging to the carrier and American Changer.

**TEST:** Before permanently installing the changer, do a functional test to verify that there is no shipping damage to your new changer.

Plug the power cord into a ***dedicated, grounded 120VAC outlet.*** The machine is preset to accept \$1, \$5, \$10 and \$20 banknotes and dispense tickets (unless otherwise specified at the time of purchase).

Fill each of the card dispensers with a minimum of 1 card. On the Main Logic Board, turn the switch on the bottom right corner “ON.” The rocker switch has an “I” and “O” printed on it. When the “I” is pressed down, the changer is “ON.”

If the machine does not function properly please contact American Changer’s Technical Support Department at [service@americanchanger.com](mailto:service@americanchanger.com) or 1-888-741-9840.

## 2.2 – Mounting Instructions

*This machine must be installed in accordance with local codes. If you are unsure in any way what your local codes are or unsure of anything in the following steps, please hire a licensed professional to mount your machine.*

1. Disconnect any and all AC power going to the machine. (Unplug AC line cord from the rear of the machine.)
2. Note: You will need to verify with the building code enforcement to see if it is allowable to plug the changer into a grounded outlet. If it is not, there must be 120VAC run through conduit or other means to meet local codes to the changer. If it is not required, proceed to step #6.
3. Have a licensed electrician run the conduit, install the new breaker, wire and help decide how the wiring will enter the changer (from the back or the bottom).
4. After the conduit has been installed, proceed with securing the machine to a stable structure.
5. Find an appropriate stable structure which to secure the machine to.
6. **NOTICE: BEFORE SECURING ENSURE THE MACHINE IS LEVEL.**

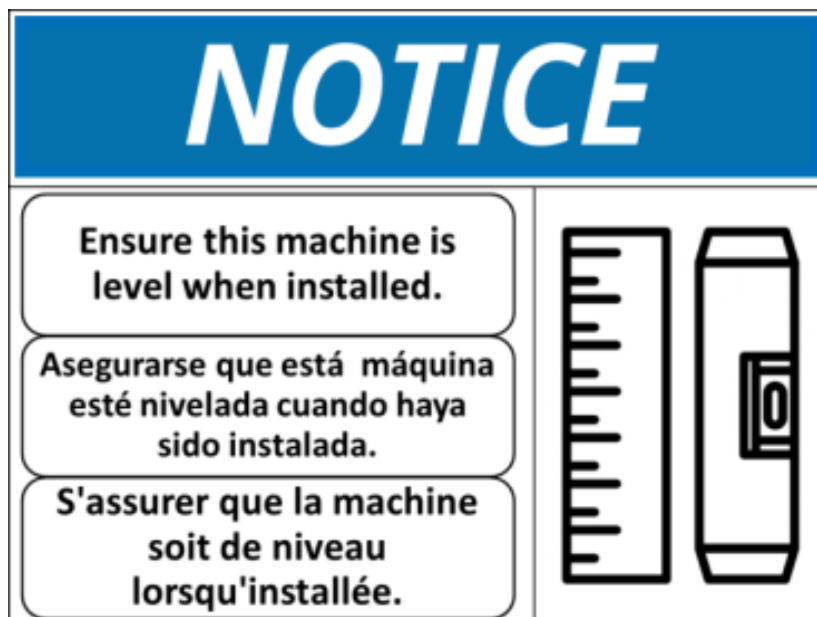



7. **⚠ DANGER**: PROPERLY SECURE MACHINE (PRODUCT) TO THE FLOOR SO THE MACHINE (PRODUCT) CANNOT BE MOVED OR TIPPED. USE STRUCTURAL SOUND FASTENERS THAT CAN BE PROPERLY TIGHTENED AND SECURE THE MACHINE (PRODUCT) THROUGH EACH OF THE HOLES IN THE BASE OF THE MACHINE (PRODUCT) TO THE APPLICABLE SURFACE TO WHICH IT IS BEING SECURED.



8. Use the four holes located in the bottom of the cabinet to secure the machine to a stable structure.
9. Verify that the machine is properly secured to the stable structure.
10. Connect your AC line to the rear of the changer. Then plug it into the outlet.
- Do not use an extension cord unless allowed by the building electrical code.**
  - Installation is completed. Proceed to the “Programming the Changer” section.

The proper performance of your American Changer machine is directly related to the quality of the power it is supplied. AC power fluctuations, including blackouts, brownouts, over voltages, sags, surges, and spikes may cause the machine to miss pay. To ensure the most trouble-free operation, we strongly recommend plugging all of our machines into a DEDICATED AC outlet (this means there are no other machines on location plugged into the same AC line). A simple way to check if this is true is to turn off the breaker associated with our machine at the breaker box. No other equipment on location should lose power.

Additionally, if your unit is located in an area prone to lightning storms or other sources of frequent power disturbances, we also strongly recommend using an Uninterruptible Power Supply (UPS). If power is lost during a payout to a customer, a UPS will allow your machines to complete the transaction that would otherwise not be completed. In some cases, a UPS may also correct long-term under and/or over voltages on the AC line by converting to the proper line voltage before the power reaches the machine.

Every American Changer machine has a surge suppressor built into the main logic board. This helps eliminate power related noise problems, but it will not protect from substantial voltage spikes or nearby lightning strikes. If this is a concern for your area, we recommend purchasing a commercial grade UPS with integrated surge protection. **NOTE: A POWER STRIP IS NOT A SURGE PROTECTOR.**

## Section 3 – Operational Overview

### 3.1 – Component Description

#### Card Dispenser

The ticket dispenser is a pulse device that interfaces through the use of a proprietary adaptor board. The AC107 and AC110 use the Benchmark Intelli-Triple ticket dispenser. All other ticket dispensing model machines use the Deltronic Labs Inc. DL 1275 ticket dispenser.

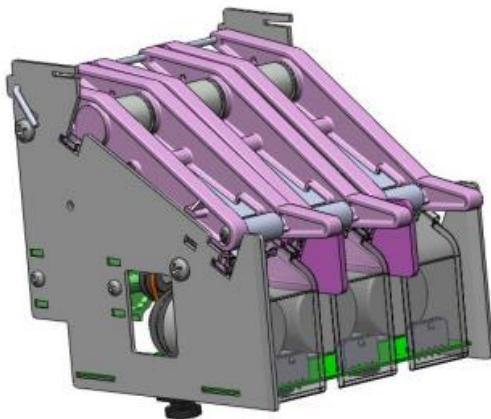

BenchMark Intelli-Triple

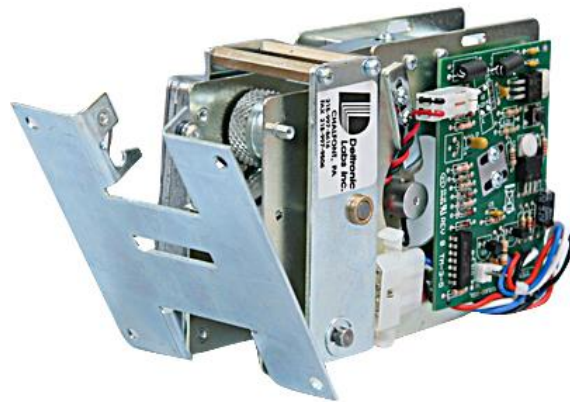

Deltronic Labs Inc. DL 1275

#### Loading the tickets into the Intelli-Triple ticket dispenser

Place the tickets in the ticket channel, positioning them on top of the ratchet and close the top slide. Be sure the top slide has magnetically set back into position.

Now press the button under the dispenser corresponding to the side you just loaded.

The Intelli-Triple will automatically position the tickets in the proper place.

Repeat the task on the other side and you are ready to go. If the machine runs out of tickets or a jam occurs, correct the problem and press the corresponding button to set the dispenser for operation.

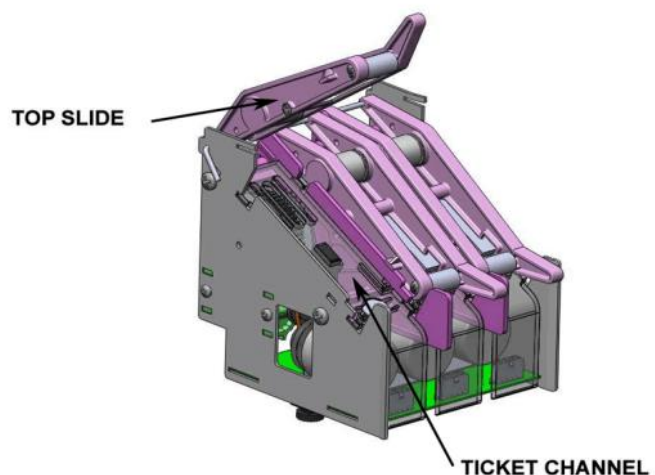

## Loading the tickets into the DL 1275 ticket dispenser

**Note: It is not necessary to detach the ticket dispenser from the door (AC111) or cabinet (AC115/125) in order to load tickets.**

1. If there are tickets remaining in the dispenser, remove them before proceeding, and empty the ticket bin. Loosen the grip of the embossing rollers by pressing the metal plate and metal spacer toward each other, using your thumb and forefinger (apply pressure at the points indicated by the two large arrows in the figure to the right). While the rollers are being held apart, use your other hand to pull the tickets out of the mechanism.
2. Refill the ticket bin with a fresh box/pack of fan fold tickets.
3. Pull the top row of tickets up, directing them around the ticket router, as seen in the picture to the right, and feed them face-up into the entrance of the ticket dispenser mechanism, between the top and bottom metal ticket guides. If necessary, gently push the locating spring out of the way with one hand while feeding the tickets with the other.
4. Making sure the tickets pass through the channel in the optical sensor, continue to push them in until the front ticket presses against the embossing rollers.
5. Locate the UP button on the Main Logic Board (see figure2). Press and hold the UP button for approximately 3 seconds until the ticket dispenser's motor begins to run, and then release the button; this initiates the ticket Auto-Feed feature on the Main Logic Board. During the Auto-Feed procedure, the tickets are pulled through the dispenser's ticket path, and automatically fed to their appropriate "standby" position, which is flush with the front of the machine.

**Note: One or more tickets may be fed through the slot during the Auto-Feed operation; these may be torn off and discarded.**

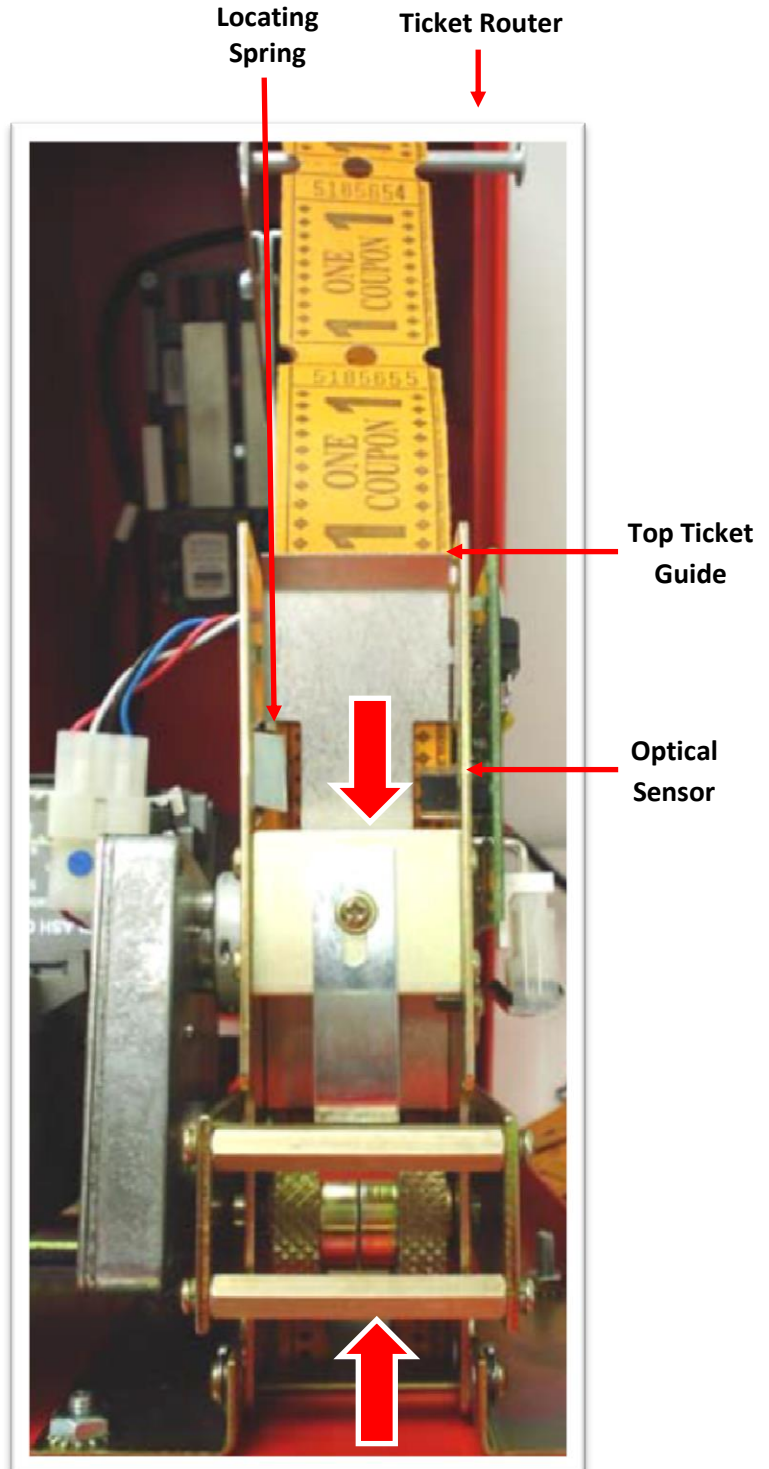

**Coin Hopper** – Only available in the AC107 and AC110

The hopper uses the ccTalk communication protocol. It can dispense coins or tokens ranging in size from 21mm to 30mm in diameter and 1.25mm to 3.30mm in thickness. An option is available to dispense smaller coins.

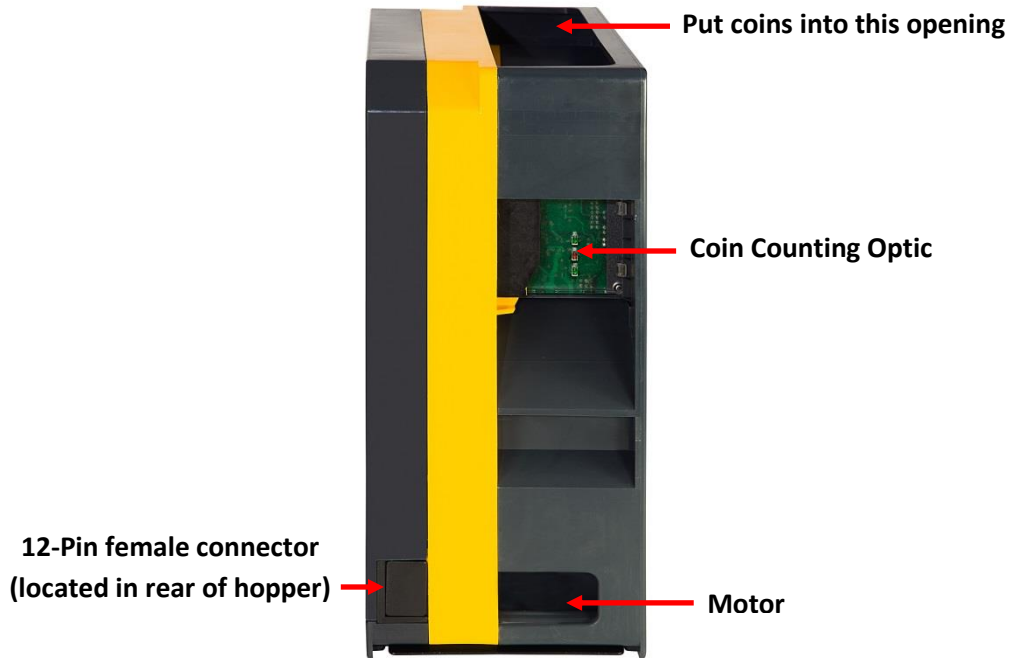

**I/O Board and External LCD Display** – Used in the AC107 and AC110

The I/O board allows the main board to interface with the LCD display and displays the packages to the customer. The LCD display is located behind the I/O board pictured below.

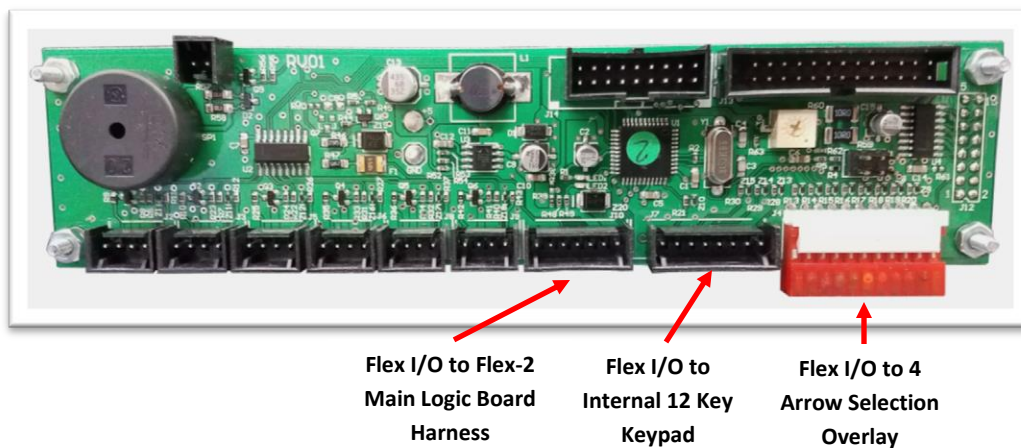

**Flex-2 Main Logic Board** – Used in the AC107 and AC110

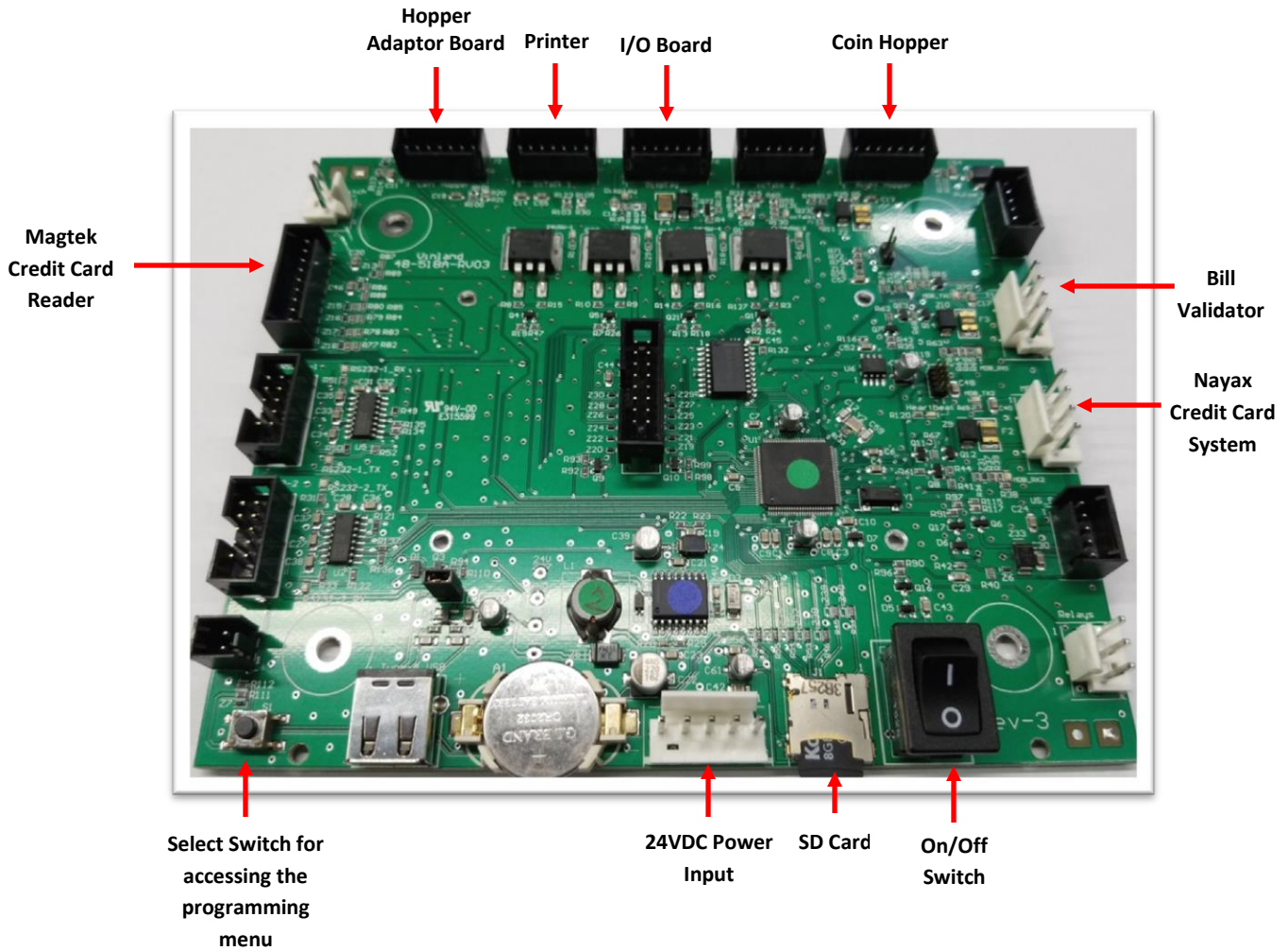

**Hopper Adaptor Board** – Used in the AC107 and AC110

The machine uses a “Hopper Adaptor Board” to control the ticket dispenser. It uses ccTalk protocol.

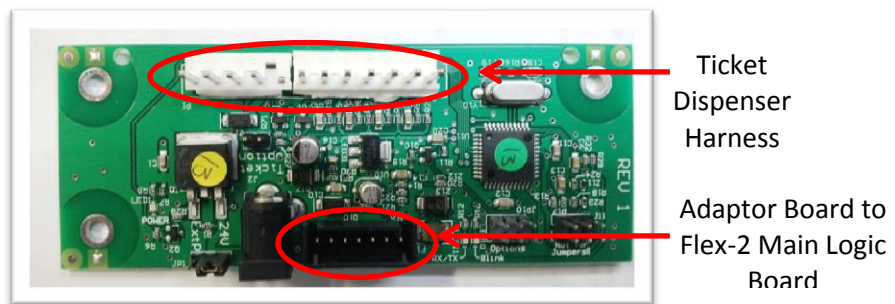

**12 Key Keypad** – Used in the AC107 and AC110

The machine uses a 12 key keypad for entering information into the programming menu. It is located inside of the machine.



**Universal Main Logic Board** – Used in the AC111, AC115, and AC125

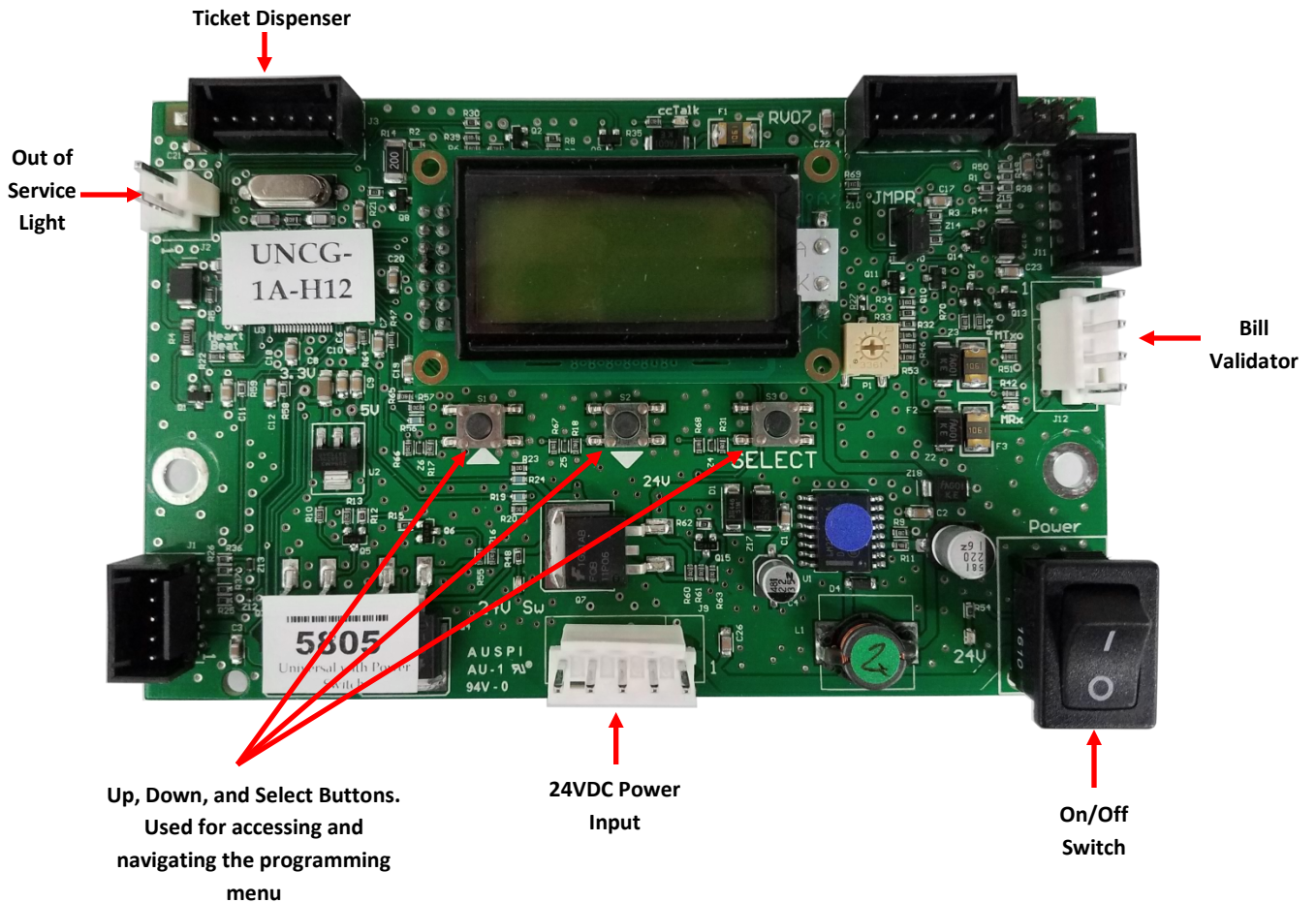

**Bill Validator** – Used in all models

This model machine may have been sold without a bill validator. It is intended to operate using a 24VDC bill validator using the MDB protocol.

*6-Pin (MDB) Connector Pinout:*

- Pin #1 - +24VDC Power
- Pin #2 - DC Power return
- Pin #3 - Not Used
- Pin #4 - Master Receive
- Pin #5 - Master Transmit
- Pin #6 - Communications Common

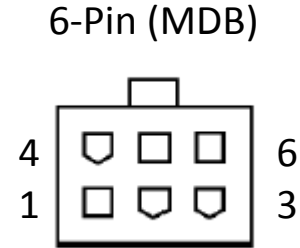

### 3.2 – Functional Description for the AC107 and AC110

- 1. **Dispense** This machine dispenses tickets and coins as change.
- 2. **Payment** The machine accepts payment in the form of cash or credit.

### 3.3 – Out-of-Service Conditions & Error Codes for the AC107 and AC110

**System Failures**

Below are conditions that will cause the machine to go into an “Out-of-Service” mode. The message “Temporarily out of Service” will be displayed on the external LCD display when the machine is in an “Out-of-Service” mode.

**Note: These error messages can only be viewed by accessing the “Programming Menu”.**

**Ticket Dispenser**

Ticket Dispenser Error Conditions

- Low Ticket Dispenser is empty.
- No Comm. The Flex-2 main logic board is unable to communicate with the card dispenser’s Hopper Adaptor Board.

**Coin Hopper**

Coin Hopper Error Conditions

- Opto’s Indicates the coin counting optic is blocked. The exit path may be obstructed, or the Optic Board may be bad.

	No Comm.	The Flex-2 main logic board is unable to communicate with the coin hopper. The hopper may be disconnected, have a damaged harness, or may need to be repaired or replaced.
	High Current	The hopper motor exceeded its maximum threshold for current. Inspect for a jammed coin preventing the coin belt from moving, or a stalled or shorted motor. Repair or replace the hopper.
	Low	The amount of coins in the coin hopper is below its operational threshold. First ensure there are enough coins in the coin hopper to completely cover the metal plates located at the bottom of the hopper. Second use Scotch-Brite to scrub the metal plates. This is effective on dull plates. Repair or replace the hopper.
	Timed Out	The coin hopper did not complete a payout in its allotted time frame. Check the hopper for any coin jams or mechanical obstructions preventing coins from exiting. Have the unit repaired or replaced.
<b>Bill Validator</b>		Bill Validator Error Conditions. If the validator fails, the display shows a "Credit Cards only" message if applicable.
	Motor	Validator stacker/transport motor has failed. Repair or replace the bill validator.
	Sensor	Sensor failure. Check for dirty sensors. Repair or replace the validator.
	Checksum	Indicates error with the firmware file stored on validator main board. Repair or replace the bill validator.
	Jammed	A bill or debris is jammed in the validator bill path. Check bill path for a jammed bill or debris. Repair or replace the bill validator.
	Cashbox	The cashbox is not installed on the bill validator. Ensure the bill box is properly installed on the bill validator. Repair or replace the bill validator.
	No Comm	The Flex-2 main logic board is unable to communicate with the bill validator.
	Can't Enable	System has tried to enable the validator several times without success.



<b>Credit Card</b>		Credit Card System error conditions. If the credit card processing fails, the display shows a “Cash only” message.
	No Comm	The Flex-2 main logic board is unable to communicate with the credit card system.
	No Reader	Reader is not connected or defective. (Only if using DataCap IPTranLT with Magtek Reader)
<b>Coin Acceptor</b>		Coin Acceptor Error Conditions
	Credit Sns.	Credit sensor blockage or failure
	Piezo Sns.	Piezo sensor blockage or failure
	Exit Sns.	Exit sensor blockage or failure
	Reject Sns.	Reject sensor blockage or failure
	Return Mech	Unit failure. Needs to be replaced.
	Thermistor	Thermistor failure
	No Comm	The Flex-2 main logic board is unable to communicate with the coin acceptor.

### 3.4 – Programming Menu for the AC107 and AC110

To enter the programming menu, begin by pressing the “Select Switch” on the Flex-2 main logic board.

Pressing the select switch will bring the display to show “Enter Access Code.”

Use the Flex Programmer Board to enter the access code. The default code from the factory is “1234”

To exit the programming menu or the “Enter Access Code” screens press the “Select Switch”

Use the Flex Programmer Board to navigate the menus. Press the “Cancel” button and enter a menu number to be brought immediately to that menu or press the **Back/Next** button to step through the menus.

All the menus work the same:

**No/Yes:** Selects status

**Back/Next:** Selects the item

**Exit:** Exits the setup menu

### **Menu 01 – Print Help Menu**

A list of the menus and their corresponding numbers is printed by the external printer.

### **Menu 02 – System Info**

The payout information and configuration settings are printed by the external printer. Aside from those, the following information is also included in the System Info printout:

Software Revision  
Valid1 Status  
Valid2 Status  
Ticket Dispenser #1 Status  
Hopper #1 Status  
Hopper #2 Status  
Hopper #3 Status  
Credit Status  
Printer Status  
Coin Acceptor Status  
Temperature Info  
FTPServer Info

### **Menu 03 – Button Price**

Define the amount charged for each selection (1-3). Selection 4 is used to purchase individual tickets.

### **Menu 04 – Button Payout**

Sets up payout count for the 3 selection buttons.

### **Menu 05 – Enable Bill**

This system only uses MDB validators. Depending on what type of MDB validator is used, the display will only toggle between the denominations accepted by the bill validator.

### **Menu 06 – Payout Table**

Only bills enabled in **Menu 05** will be available in this menu. Enter the # of items dispensed for each bill denomination.

### **Menu 07 – Enable Hoppers and Ticket Dispenser**

Enable or disable the ticket dispenser.

Enable or disable the coin hopper. **Note: The software shows hoppers 1, 2, and 3. This machine only uses hopper 1.**

### **Menu 08 – Hopper Coin Value and Ticket Value**

Set the value of the coin being dispensed. This is for when providing change.

Set the value of the ticket dispensed when using selection 4.

### **Menu 09 – Enable Coin Acceptor**

Select between a Pulse or ccTalk coin acceptor. Enable or disable the coin acceptor.

Pulse – Enable → High or Low

ccTalk – Enable → Coin Values

**Menu 10 – System Disable**

Puts the machine in an “Out-of-Service” mode if any of the selected devices go offline.

Ticket 1

Hopper 1

Hopper 2 (Not Used)

Hopper 3 (Not Used)

**Menu 11 – Promo-Token Payout**

Enter the # of items paid for each promotional token.

**Menu 12 – Dump Hoppers**

Dumps the coins from all hoppers.

**Menu 13 – Audit Information**

Prints a summary of all the sales. There are separate counters for tokens dispensed from each hopper.

Reset – Prints 2 copies of all the audit values and resets all the “**Resettable Counters**” to 0.

Every time **Reset** button is pushed the audit sequence number increases by one.

The “**Non-resettable Counters**” can be set to 0 by a hidden “Memory Dump”.

Print – Pushing the **Print** button prints all the audit values without resetting.

All the values are max 99,999 except for the **Total Cash** value which is \$100,000.00.

**Menu 14 – Vend Item Name\***

Choose from Items, Tickets or Tokens.

**Menu 15 – Date Setup**

Enter the date in this format: 20YY-MM-DD.

**Menu 16 – Time Setup**

Enter the time in this format: HH:MM. 24 hour format.

**Menu 17 – Machine Number**

Assign a machine number that will appear in audit report print out.

**Menu 18 – Marquee Timer\***

Setup a time to turn On/OFF the marquee.

**Menu 19 – Zip Code Enable\***

Enable or disable zip code verification for credit card transactions.

**Menu 20 – Access Code**

Change the access code.

**Menu 21 – Key Beep Enable**

Enable or disable beep when a button is pressed.

**Menu 22 – Location Name**

Enter location name to print on credit card receipts.

**Menu 23 – Printer Options**

Credit Card and Cash receipt printing options: Always, Never, or Prompt.

Receipt length options: Long or Short.

Cut options: Full or Partial.

**Menu 24 – Validator Enable**

Enable or disable the bank note validator.

**Menu 25 – Nayax Test Mode**

This is used to verify Nayax messages. It is only used for during testing. It must be off during normal operation.

**Menu 26 – Country**

Select between U.S and U.K. Selecting U.S. displays “\$”. Selecting U.K. displays “£” and “p”.

**Menu 27 – FTP Server**

Configure WebServer IP, gateway, DNS, port, network password and software update.

**Menu 28 – Minimum Credit**

Enter a minimum monetary amount for credit card transactions.

**Menu 29 – Anti Stringing**

Setup maximum cash amount, maximum time and shut-off time for anti- stringing purposes.

**Menu 30 – Programmer**

Enable or disable dual display mode. In dual display mode the Flex Programmer Board is able to be used as a secondary display to access the programming menu.

## 3.5 – Remote Loading Software to the Flex-2 Board for the AC107 and AC110

### 1. What you need

- 1.1 Windows XP, or later pc with MicroSD port or USB to MicroSD card reader
- 1.2 MicroSD card (comes installed in the Flex-2 main logic board)

### 2. Transferring the file into the MicroSD card

- 2.1 Turn power off to the controller board.
- 2.2 Remove SD card.
- 2.3 The software is in a zip format and will be sent as an attachment to an email.
- 2.4 Save the zipped file and then unzip it.
- 2.5 **Do not change the name or the file extension!!!**
- 2.6 Copy the program file to the SD card.

### 3. Loading the file from the MicroSD card to the controller board

**Note: All system settings will be erased once software is updated!!! We recommend making a print out of the settings before doing anything.**

- 3.1 Turn power off to the controller board.
- 3.2 Gently push the MicroSD card into the MicroSD connector on the board.
- 3.3 Turn power on while holding the Button on the board for 2 seconds then release.

**Update Software?** Press **Yes** to continue loading the software. Press **Exit** to cancel.

- 3.4 Once the **Yes** key has been pressed a brief reminder will be displayed followed by a confirmation.

**System Settings will be erased if Updated** – This reminder will stay on for a few seconds before transitioning to the final confirmation message.

**Update: XXXX-XX-XXX Start Next Exit** – Press **Start** to load the software. Press **Next** view the next file loaded on the MicroSD card or Press **Exit** to cancel.

- 3.5 Software updating and completion.

**Update: XXXX-XX-XXX Addr : 0x00012000** – Software name and flash memory address being programmed. Address should be cycling every ½ second.

**Software Updated! Please Cycle Power** – Cycle power to complete update.

### 4 Error messages:

One of the following messages may occur if there is **a problem loading the software**. In that case, remove the MicroSD card and check that the correct file is loaded on the MicroSD card.

- 4.1 **EEPROM Error Please Try Again** – EEPROM error.
- 4.2 **Main CRC Error V:XXX Update Required!** – The computed main program CRC is incorrect.
- 4.3 **Frame Error V:XXX While Reading File** – There was a checksum error while reading one of the files entries.

**THE FOLLOWING IS A FATAL ERROR AND THE BOARD CAN NOT BE USED!!**

- 4.4 **Fatal Error V:XXX Invalid Boot CRC!** – Do not load any software if this message occurs.

### 3.6 – Functional Description for the AC111, AC115 and AC125

1. **Dispense** This machine dispenses tickets and coins as change.
2. **Payment** The machine accepts payment in the form of cash only.

### 3.7 – Out-of-Service Conditions & Error Codes for the AC111, AC115 and AC125

#### System Failures

Below are conditions that will cause the machine to go into an “Out-of-Service” mode. While in this mode the out-of-service light will be illuminated and the machine will not accept any payment.

**Note: These error messages will be displayed on the LCD display in the form of an alternating message of “Fail”, current “Total” counter, followed by the error message.**

#### **Ticket Dispenser**

Ticket Dispenser Error Conditions

Ticket Timeout

The ticket dispenser does not have specific sensors for monitoring when the tickets run out. Instead, the main logic board reads its optical notch sensor output and applies a time-out to determine when the ticket bin is out of tickets. During normal operation, the logic board turns on the dispenser and monitors the notch sensor output to turn it off when the correct number of tickets has been dispensed. If too much time passes before a notch is read, the bin is deemed to be out of tickets and the **Ticket Timeout** error message is displayed.

#### **Bill Validator**

Bill Validator Error Conditions.

Validat. Full

The Bill Stacker is full of bills and should be emptied.

Validat. Motor

Validator stacker/transport motor has failed. Repair or replace the bill validator.

Validat. Sensor

Sensor failure. Check for dirty sensors. Repair or replace the validator.

Validat. CheckSum

Indicates error with the firmware file stored on validator main board. Repair or replace the bill validator.

Validat. Jammed	A bill or debris is jammed in the validator bill path. Check bill path for a jammed bill or debris. Repair or replace the bill validator.
Validat. Cashbox	The cashbox is not installed on the bill validator. Ensure the bill box is properly installed on the bill validator. Repair or replace the bill validator.
Validat. No Comm	The Universal main logic board is unable to communicate with the bill validator. Check validator harness connection. Repair or replace the bill validator.
Validat. Disabled	System has tried to enable the validator several times without success. This may be a communication issue, and may be temporary. Check validator harness connection. Repair or replace the bill validator.
Validat. String	The changer's Anti-Stringing protection has shut down the machine's operation. This means more money has been inserted in less time than allowed by the system's settings. Wait the allotted time, or reset the machine to resume operation.

### 3.8 – Programming Menu for the AC111, AC115 and AC125

**Note: The software settings on the Main Logic Board are programmed at the factory, and do not need to be altered under normal circumstances. Only if you wish to change the operation of your ticket dispenser should you enter the Program Mode to make changes.**

The following is a description of the various menu options that are available in the Ticket Dispenser software (refer to Table 1 for a chart showing all of the software options). **Note: Not all of the menus are used in the AC111/115/125 series Ticket Dispensers.** Read the following for a detailed explanation of the menus that are used, as well as instructions on how to access the Programming Menu and to make and save your desired changes.

#### Accessing the Programming Menu

To enter the programming menu, begin by pressing the “Select” button on the Universal main logic board. Refer to page 12.

Use the “Up▲” and “Down▼” buttons to navigate through the menus. Scroll down to “Exit” and press the “Select” button to exit the programming menu.

## Bills

Accept – This menu controls which bills are accepted and rejected by the bill validator. To accept a bill set the denomination option to “Y”. To reject a bill set the denomination option to “N”.

Security – This menu controls how strict the bill validator is at reading the bills.

**Note: AC111/115/125 series Ticket Dispensers do not have the ability to make change, so keep this in mind when selecting which bill denominations will be accepted. For example, using a \$5 bill to pay for a 3-dollar ticket will cause the machine to dispense 1 ticket and hold two dollars in escrow. These two dollars can only go towards the purchase of another ticket, i.e. by inserting another dollar. If the machine does not accept \$5 or higher bills, the customer can only pay with ones, and will receive a ticket for every three dollars inserted.**

Total 00000	Bills	Accept	\$1	\$5	\$10	\$20	\$50	\$100
			Y	Y	Y	Y	Y	Y
			N	N	N	N	N	N
		Security	Exit	Exit	Exit	Exit	Exit	Exit
			High					
			Low					
		Exit						

## SETTING TICKET PAYOUTS

### PAYOUT

Enter this menu to set the price of tickets. The first setting that is displayed is the individual ticket price, called “Ticket”.

The next menu settings are ticket payouts for each accepted bill denomination. Setting ticket payouts this way enables you to dispense bonus tickets when certain bill denominations are used. If no bonuses are desired, then set all bill denomination payouts to “000”. Setting the bill payouts to “000” will not pay out zero tickets, rather, the individual ticket price set in the first step will be used for all additional tickets (see examples below for further explanation). **Note: When ticket payouts are set to non-zero numbers for individual bill denominations, those numbers override the individual ticket price, and will be the number of tickets dispensed when that bill is accepted. If the individual ticket price is to be used for all tickets, with no bonuses, then set all bill payouts to “000”.**

**EXAMPLE #1:** To pay out 6 tickets per dollar, with a one-dollar bonus payout for \$5 bills, a three-dollar bonus payout for \$10 bills, and an eight-dollar bonus payout for \$20 bills, make the following settings:

**Ticket** = any value less than \$1.00 – \$0.25 for simplicity

**\$1** = 006 (\$1 x 6)

**\$2** = 012 (\$2 x 6)

**\$5** = 036 (\$5 x 6 plus \$1 x 6)

**\$10** = 078 (\$10 x 6 plus \$3 x 6)

**\$20** = 168 (\$20 x 6 plus \$8 x 6)



**EXAMPLE #2:** To dispense \$7.00 tickets with NO bonuses, i.e. \$7 for 1 ticket, \$14 for 2 tickets, \$21 for 3 tickets, etc., make the following settings:

**Ticket** =\$7.00

**\$10** = 000 (\$1, \$2, and \$5 do not appear)

**\$20** = 000

For these settings, when a \$20 bill is inserted, two tickets will be paid out. Insert a \$1 bill next, and a third ticket is paid. Alternatively, insert four \$1 bills, and then a \$10 bill, and two tickets will be dispensed.

**NOTE: Always run tests using every accepted bill denomination once the ticket payouts have been set, to be sure they are correct and how you want them before final installation of the dispenser. The payouts can be set and reset as much as needed, and can be changed at any time to meet your requirements.**

Total 00000	Pay Out	Ticket	\$1	\$5	\$10	\$20
		Set Ticket Value	Set Payout	Set Payout	Set Payout	Set Payout
		\$00.05 - \$20.00	000 - 999	000 - 999	000 - 999	000 - 999

## HARDWARE SETTINGS

### **HARDWARE**

The ticket dispenser’s hardware settings are mostly dependent on what hardware is installed in the unit. Aside from the “String” submenu, the hardware options should not be altered unless they are accidentally changed, or as part of troubleshooting if the unit is not working. The following describes the proper factory settings in case they need to be reset.

**Hoppers** – The AC111/115/125 series Ticket Dispensers are not available with hoppers, so this submenu should always be set to the option “None!”.

**Coin Acceptor** – AC111/115/125 series Ticket Dispensers are not available with a coin acceptor, so this submenu should always be set to the option “None!”.

**Dump** – This option controls the unloading of a hopper, which is not available on AC111/115/125 series Ticket Dispensers. Setting this option to either Yes (Y) or No (N) has no effect on the operation of the dispenser, so it may be left in its current state.

**Mode** – Only the “Many” mode, where the amount of money accepted by the validator is entirely changed to tickets is available on the AC111/115/125 series Ticket Dispensers. Setting this mode to either “One” or “Many” has no effect on the operation of the dispenser, since it defaults to “Many”, so it may be left in its current state.

## ANTI-STRINGING PROTECTION

**String** – Configures the settings that help against “Stringing”. Select ‘String,’ and then choose either (Y) to enable stringing protection, or (N) to disable it. If Yes is chosen, there is a series of three settings that will follow, explained next, that together control the behavior of the changer with regard to stringing.

**Max \$** – This setting is the maximum dollar amount that can be accepted by the machine within the user-set time limit (next setting) before triggering the anti-stringing protection. The dollar amount can be chosen anywhere between \$20 and \$200 in \$5 increments.

**Max Time** – The time entered here is the time limit for the changer accepting the user-set maximum dollar amount (previous setting). If the changer accepts the maximum dollar amount within the amount of time set here, anti-stringing protection will be triggered. The length of time can be set to anywhere between 5 and 120 minutes in 5 minute increments.

**Shut Off** – This setting controls the anti-stringing protection, which is the shutting down of the changer for the time specified here. The changer can be set to shut down for 15, 30, 45, or 60 minutes, or until the MLB is reset by turning the power off then back on (‘Reset’).

Total 00000	Hardware	String	String	Yes
			Yes	Max \$
				Max Time
				Shut Off
			No	
Exit				

## Section 4 – Maintenance

**⚠️ WARNING** : DISCONNECT ALL ELECTRICAL POWER TO THE MACHINE BEFORE SERVICING.

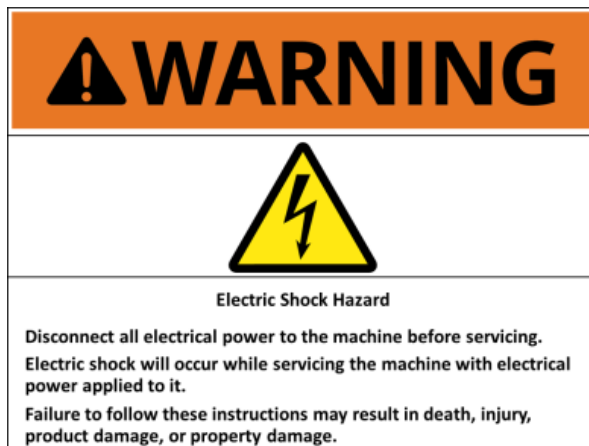

### 4.1 – Ticket Dispenser Maintenance

Using a cotton swab and isopropyl alcohol (rubbing alcohol), thoroughly clean the rollers.

Using a small piece of cloth, dampened with isopropyl alcohol, wipe all metal surfaces on the interior of the unit.

Occasionally, the optic sensors may become dirty. Simply wipe them with a clean, dry cloth periodically to remove any dust buildup.

It is a good idea, during the maintenance session, that the unit be visually inspected for broken or damaged parts, worn parts, and debris buildup.



## 4.2 – Banknote Validator Maintenance

### Pyramid Acceptors Apex Model

The Apex Series note acceptor is relatively maintenance free. An occasional cleaning is all that is needed to keep the acceptor in top operation. **Please Visit the “service” section of the [pyramidacceptos.com](http://pyramidacceptos.com) website to view videos explaining how install, clean, program, and troubleshoot the Apex bill acceptor.**

To clean the acceptor:

- Remove power from the machine.
- If equipped with a stacker, unlatch the cassette by pushing in the top latch and lifting the cassette up and out.
- Unplug the I/O connector and/or power connector from the right side of the acceptor.
- Remove the Lower Transport by pushing in the latch located on the bottom of the acceptor at the rear. Gently pull the Lower Transport out of the assembly.
- Clean the bill path using a soft cloth or towel. Do not use any cleaners other than a 50/50 mixture of water and isopropyl alcohol.

**NOTE: Pay particular attention to the gray oval pieces of plastic in the lower and upper transport area. They must be cleaned well for proper operation.**

**Do not use any oils or silicon spray on the acceptor!**

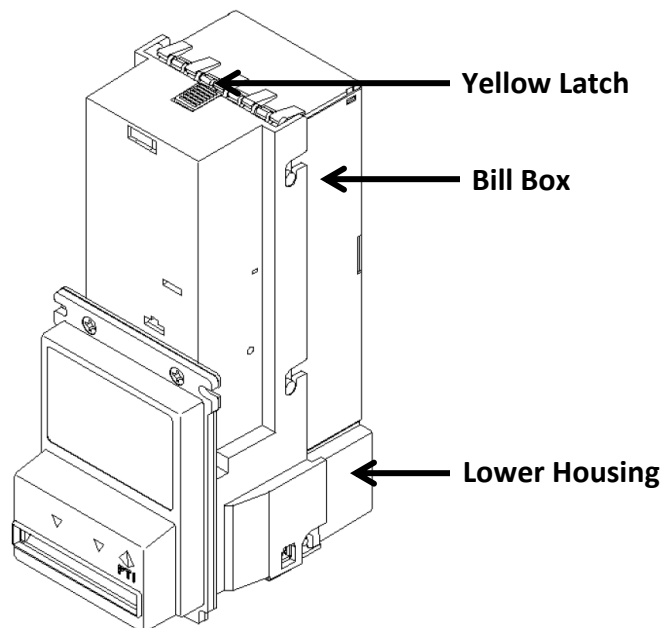

## Crane Payment Innovations (CPI) AE 2600 Series

You can clean the note acceptor while it is still mounted in the machine

1. Remove power from the machine.
2. Unlatch the magazine by pushing the yellow latch (located on the top of the unit) toward the front of the unit.
3. Unhook and remove the magazine by holding the latch and lifting up and then back on the magazine.
4. Unlatch the LED Housing by lifting up on the metal bar (located below the Status LED).
5. Remove the LED Housing by holding the metal bar and pulling back on the LED Housing.
6. Clean the bill path with a soft cloth. You may use mild, non-abrasive, non-petroleum based cleaners if sprayed on the cloth.

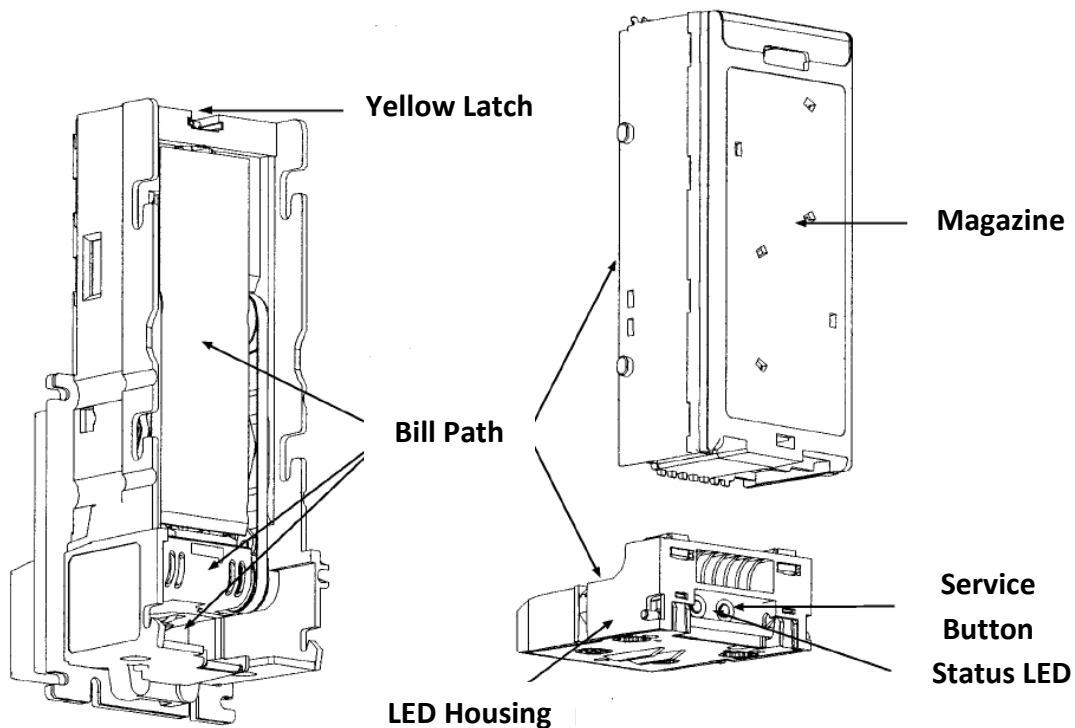

## Astro Systems GBA ST1-C

### Cleaning the Validator Note Path

#### Equipment Required

- Cotton swab or lint-free cloth.
- Cleaning solution - a mix of water and up to 50% Iso-Propyl Alcohol (IPA) is recommended.
- **DO NOT** use more than 50% IPA. **NEVER** use solvent-based cleaning agents, such as Amberclens, pure alcohol, petrol, methylated spirit or white spirit on this product as the unit will be severely damaged.

#### **Anti-Static precautions should always be observed when cleaning the GBA ST1C unit.**

1. Ensure the power supply to the GBA ST1C unit is switched OFF.
2. Remove the Cassette.
3. Lift up the purple Access Latch on the back of the Bottom Sensor Assembly, and gently slide the module out of the Channel Assembly.
4. Pick off and discard any large items of debris from the note path of the Bottom Sensor Assembly. Repeat for the other side of the note path (on the drive belt assembly).
5. Using the cotton swab, or lint-free cloth, wetted with cleaning solution and applying light force only, carefully clean all sensor windows in both halves (upper and lower) of the note path. If a sensor window has become badly scratched do not attempt to polish it, contact your local regional office for further advice.
6. Continue with the swab, or lint-free cloth, to clean the rest of the note path, including sprung rollers.
7. Visible parts of belts can be cleaned by wiping with a cleaning solution-soaked cotton swab or wipe. It is not possible to clean the whole belt surface without removing the belts from the unit.
8. Use an additional swab or cloth to dry the cleaned area, if required.
9. Slide the clean Bottom Sensor Assembly back into the Channel, ensuring that the Access Latch clips securely into the Channel.
10. Re-fit the Cassette.
11. The supply to the unit can now be switched ON.

### Clearing a Note Jam

1. Ensure the power supply to the GBA ST1C unit is switched OFF.
2. Remove the Cassette.
3. Lift up the purple Access Latch on the back of the Bottom Sensor Assembly, and gently slide the module out of the Channel Assembly.
4. Clear the jammed note(s) from the note path.
5. Re-assemble unit and switch the power supply back ON.



## 4.3 – Coin Hopper Maintenance

### Removal of the Electronics and Opto Sensor Board

All the electronics and sensors are placed on one board located behind the exit door at the side of the hopper. Slide the yellow button to the opposite position and remove the exit door where the electronics are mounted. All dirt must be cleaned with a soft moistened cloth. Isopropyl Alcohol is recommended for cleaning excessively dirty exit windows. The red LED on the exit window board will begin flashing indicating a dirty opto-sensor.

**Warning:** Be careful when re-inserting the board back in the hopper not to damage the cable located at the back of the board!

### Low Coin Contact Plates

Looking inside the hopper through the top opening locate the two brass plates at the bottom of the hopper. If they appear to be dull and/or dirty remove the right section of the hopper by removing the 6 screws on that side. Use a Scotch-Brite pad, or another item made with abrasive material, to scrub the oxidation and dirt off of the brass plates.

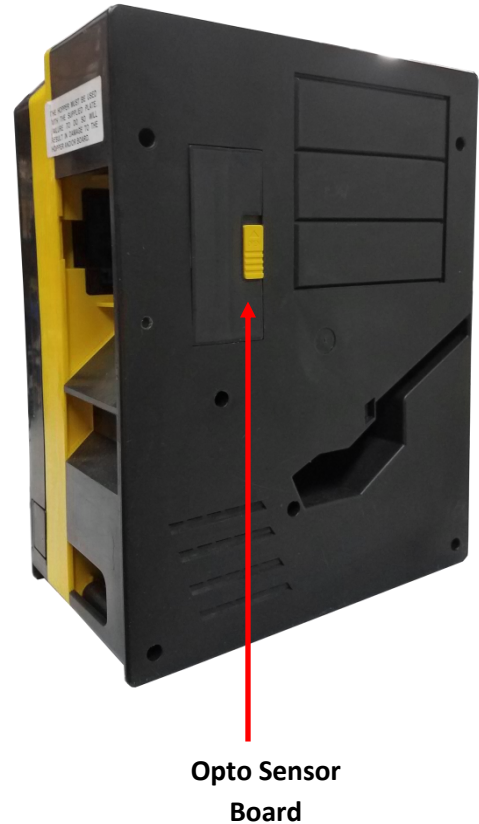

**Opto Sensor  
Board**



## 4.4 – Warranty Terms and Conditions

**LIMITED WARRANTY AND EXCLUSIVE REMEDIES** – The goods delivered hereunder are subject to the terms of American Changer Corporation’s (Seller or Seller’s) Limited Warranty provided with the deliverable, or if there is no such warranty, the terms set forth herein. In the event of any inconsistency between the written warranty provided with deliverable, and the description of the warranty set forth herein, the written warranty shall govern.

Seller warrants that its new products and parts are free from defects in material or workmanship in normal use for one year from the date of shipment by Seller. In addition, this warranty will be extended for a second year for Bill Validators. Refurbished parts carry a six-month warranty from date of shipment by Seller.

Seller will furnish without charge, F.O.B. Fort Lauderdale, repair or replacement of any defective part qualifying for repair and/or replacement under the terms of its warranty, within one year of the date of delivery. Any transportation, diagnosis calls, or similar expenses are not included. The warranty for any replacement part will only apply to the remainder of the warranty period.

This warranty may not be changed or modified without the consent of an Executive Officer of Seller.

To make a claim under this warranty, Buyer must call Seller’s Service Department and provide the model number and serial number of the goods. If the goods were purchased from a reseller, Buyer must provide the name, address and telephone number of the reseller. Seller reserves the right to request proof that the reseller purchased the goods from the Seller.

Seller’s Limited Warranty does not cover damage caused by: (I) shipping or physical abuse; (II), misapplication or misuse including improper installation, startup, storage, or failure to comply with any instructions for use set forth in the owner’s manual supplied with the goods, or use, storage or operation of the goods in a manner that fails to comply with all applicable laws, rules and regulations, including, without limitation, any local labeling requirements or labeling required under California’s Safe Drinking Water and Toxic Enforcement Act of 1986 (also known as “Proposition 65”) and its implementing regulations; (III) failure to perform necessary maintenance and cleaning in accordance with the owner’s manual provided with the goods or comply with all applicable law or regulation, all applicable labeling requirements (IV) power surges, improper electrical supply and/or lightning strike; (V) operation, use or storage of goods in weather or outdoor conditions which do not comply with the guidelines set forth in the owner’s manual supplied with the goods; and (VI) fires, floods, or other casualty or Acts of God outside of Seller’s control.

This warranty is void if: (I) repairs and/or replacement are performed by anyone other than Seller or a qualified repair technician; (II) the goods were purchased in a used condition or not in the original packaging; (III) the goods have any defects or damage due to any alterations, or damage caused by improper electrical supply, shipping and handling, fire, flood, misuse, vandalism, or any other condition or event outside of Seller’s control, or the goods are used , stored or operated in a manner that fails to comply with any applicable law, rule, or regulation,

including, without limitation any local labeling requirements or labeling required under California’s Safe Drinking Water and Toxic Enforcement Act of 1986 (also known as “Proposition 65”) and its implementing regulations; (IV) the failure to clean and maintain the product in accordance with the owner’s manual supplied with the goods or comply with all applicable law and regulations and any applicable labeling requirements; (V) the goods are operated, used, or stored in weather or outdoor conditions which do not comply with the guidelines set forth in the owner’s manual.

The owner is responsible for: (I) using the goods supplied by the Seller in accordance with the installation, start-up, use, storage, inspection, and service requirements, and all other instructions set forth in the owner's manual supplied with the goods; (II) providing normal cleaning and maintenance in accordance with the owner's manual supplied with the goods; (III) operating, using, and storing the goods in accordance with the owner's manual supplied with the goods and in compliance with all applicable laws, rules, or regulations, including any local labeling requirements or labeling required under California's Safe Drinking Water and Toxic Enforcement Act of 1986 (also known as "Proposition 65") and its implementing regulations; (IV) contacting American Changer during the warranty period to obtain a Return Material Authorization to make a claim under this warranty; (V) providing proof of purchase if requested, and if the goods were purchased from a reseller, the name, address, and telephone number of the reseller; (VI) providing any other information American Changer may reasonably request to confirm that the goods are eligible for repair/replacement under this warranty; (VII) paying for any repairs or replacement of parts outside the scope of this warranty; (VIII) paying any shipping costs.

#### **ENTIRE WARRANTY**

**THIS WARRANTY CONSTITUTES THE EXCLUSIVE REMEDY OF THE PURCHASER AND IN LIEU OF ALL OTHER WARRANTIES, EXPRESS OR IMPLIED, INCLUDING, WITHOUT LIMITATION, ANY IMPLIED WARRANTY OF MERCHANTABILITY OR FITNESS FOR A PARTICULAR PURPOSE TO THE EXTENT PERMITTED BY LAW.**

**SELLER EXPRESSLY DISCLAIMS ALL LIABILITY ARISING OUT OF THE THEFT, MISAPPROPRIATION, OR MISUSE OF ANY PERSONAL FINANCIAL INFORMATION OF AN END USER OF THE GOODS, INCLUDING, BUT NOT LIMITED TO, CREDIT CARD AND/OR DEBIT CARD NUMBERS, PERSONAL IDENTIFICATION NUMBERS, PERSONAL PASSWORDS OR PASSCODES, OR OTHER SIMILAR PERSONAL INFORMATION OF THE USER OF THE GOODS.**

**IN NO EVENT SHALL AMERICAN CHANGER BE LIABLE TO BUYER UNDER THIS WARRANTY FOR AN AMOUNT WHICH EXCEEDS THE PURCHASE PRICE OF THE GOODS.**

**IN NO EVENT SHALL AMERICAN CHANGER BE LIABLE FOR ANY INCIDENTAL OR CONSEQUENTIAL DAMAGES OR LOST PROFITS, OR FOR DAMAGES ARISING OUT OF BUYER'S INSTALLATION, OPERATION OR STORAGE OF THE GOODS IN A MANNER THAT FAILS TO COMPLY WITH ANY APPLICABLE LAW, RULE, OR REGULATION, INCLUDING ANY LABELING LAW, RULE OR REGULATION INCLUDING, WITHOUT LIMITATION, CALIFORNIA'S SAFE DRINKING WATER AND TOXIC ENFORCEMENT ACT OF 1986 (ALSO KNOWN AS "PROPOSITION 65") AND ITS IMPLEMENTING REGULATIONS.**

**SELLER EXPRESSLY DISCLAIMS ALL GUARANTEES AND/OR WARRANTIES, EXPRESS OR IMPLIED, INCLUDING WARRANTIES OF MERCHANTABILITY AND FITNESS FOR A PARTICULAR PURPOSE, OR USEFUL LIFE.**

**LIMITATIONS OF DAMAGES** – Seller's liability for any loss or damage arising out of, or resulting from, any breach or default by Seller in connection with the sale of goods hereunder, shall not exceed the purchase price thereof, regardless of whether such liability arises in contract, tort (including, without limitation, negligence or strict liability) or otherwise, and in no event shall Seller be liable for incidental or consequential damages of any kind or for lost profits.

Buyer is solely responsible for installing, storing, operating and maintaining the goods delivered hereunder in compliance with all applicable laws, rules and regulations, and any local labeling requirements or labeling required under California's Safe Drinking Water and Toxic Enforcement Act of 1986 (also known as "Proposition 65") and its implementing regulations. In no event shall Seller be liable for Buyer's failure to install, store, operate or maintain the goods in compliance with any applicable law, rule or regulation.

**WARRANTY FORM**

The Warranty Form must be filled out completely and mailed to:

American Changer Corp.

1400 NW 65<sup>th</sup> Place

Ft. Lauderdale, FL 33309

Attention: Extended Warranty Department

**Machine Information**

Machine Model & Serial Number:	_____
Validator Serial Number:	_____
Validator Serial Number:	_____
Hopper Serial Number:	_____
Hopper Serial Number:	_____
Logic Board Serial Number:	_____
Coin Mechanism Serial Number:	_____
Your Name:	_____
Company Name:	_____
Billing Address:	_____
Billing Address:	_____
City:	_____
State and Zip Code:	_____
Phone Number:	_____
Email Address:	_____

Note: The purpose of this form is to enter your information in our customer database. This information will not be shared with anyone outside of American Changer Corp. It will be used to inform you of equipment upgrade