

# VALICHANGER OPERATIONS MANUAL SERIES AC8004

**American Changer Corp.**  
1400 NW 65<sup>th</sup> Place  
Ft. Lauderdale, FL 33309

**Parts & Service:**(888)741-9840  
**Sales:**(800)741-9840  
**Fax:**(954)917-5204

*Internet Address:* [www.americanchanger.com](http://www.americanchanger.com)

**Service Questions? e-mail:** [service@americanchanger.com](mailto:service@americanchanger.com)



## UNCRATING AND SET-UP

Remove your Series AC8004 changer from the shipping box. Open the door. The matching locks and keys for your changer will be inside the manila envelope along with this manual. To install the locks, insert the cylinders into the round holes and push until they stop. Turn the key counter-clockwise ¼ turn and remove the keys.

**NOTE: The only way to get a duplicate set of keys made is to save the SILVER tag that comes between the keys.**

### TEST:

Before permanently installing the changer, do a functional test to verify that there is no shipping damage to your new changer(s).

Extend the power extension cord through the hole in the back of the changer or the bottom and plug it into a **grounded 120vac outlet**. The dip switches are already set for a 4 coin per dollar pay-out of the hopper, and the Bill validator is ready to accept \$1-\$5-\$10-\$20 dollar bills.

**Fill the hopper with at least 100 coins.** On the main logic board turn the switch on the bottom right corner "ON". (SEE FIG. 1 ON PG.3) *The rocker switch has a "1" and "0" printed on it. When the "1" is pressed down the changer is "ON".*

### MOUNTING THE AC8004 INTO A WALL

***IF YOU ARE UNSURE IN ANY WAY IN PROCEEDING WITH THE FOLLOWING STEPS, PLEASE HIRE A LOCAL PROFESSIONAL ELECTRICIAN TO MOUNT YOUR CHANGER FOR YOU!***

1. Disconnect any and all AC power going to the series 1002 changer. (See fig. 1)
  - A. Unplug the AC line cord from the bottom of the board.
  - B. Unplug the validator connectors on the right side of the board.
  - C. Unplug the hopper harness connector on the left side of the board.
  - D. Unbolt the ground wire from the right side of the cabinet.
  - E. Remove the main logic board and hopper from the inside of the changer.
  - F. Put the nuts back on the studs to avoid losing the brass spacers on the studs.
2. Slide the hopper out of the cabinet.
3. Note: You will need to verify with the building that it is allowable to plug the changer into a 3 prong grounded outlet. If it is not, there must be 120VAC run through conduit to the changer. If it is not required, proceed to step #6.
4. Let the electrician run the conduit, install the new breaker, wire and help decide how the wiring will enter the changer (from the back or the bottom). This will affect the mounting location.
5. After the conduit has been installed, proceed with the mounting.
6. Using a stud locator, find a location to hang the changer by locating the wall studs.

7. Find an appropriate wall to bolt the changer into. The wall should have studs or be constructed of concrete. Consult a professional with any questions you may have.
8. **NOTE: SECURING THE CHANGER FROM LESS THAN 4 BOLTS OR WELDED ANGLE IRON MAY BE DANGEROUS. EACH HOLE NEEDS A BOLT THROUGH EACH ONE MOUNTED SECURELY INTO THE WALL. MOUNTING THE CHANGER IN ANY OTHER WAY MAY RESULT IN THE CHANGER BEING TORN OFF OR FALLING OFF THE WALL RESULTING IN PERSONAL OR CUSTOMER INJURY ALONG WITH ELECTRICAL SHOCK.**
9. Choose a height to mount the changer keeping in mind that a handicapped person in a wheelchair should still be able to insert a bill into the bill validator. (We recommend no higher than 4 feet above the ground.)
10. Have someone hold the changer into the wall while someone else marks the holes. **CAUTION: THE CHANGER WEIGHS 85 POUNDS DO NOT EXERT YOURSELF SO THAT YOU MAY CAUSE AN INJURY.**
11. **BEFORE DRILLING THE FOUR MARKED HOLES ENSURE THAT THERE ARE NO ELECTRICAL WIRES, TELEPHONE LINES, GAS, OR WATER LINES BEHIND THE WALL WHICH DISRUPTING MAY CAUSE A LOSS OF LIFE OR PERSONAL INJURY!**
12. Put the changer back into the wall. Thread and tighten bolts.
13. Verify that the machine is securely mounted.
14. Reinstall the main logic board.
  - A. Before installing the main logic board, verify that the plastic safety-insulating sheet is still against the back wall where the board will be mounted and that there is a 3/8" spacer on each stud.
  - B. Install the main logic board and properly tighten the nuts.
  - C. Re-bolt the ground wire into the right side of the cabinet.
  - D. Plug the validator connector into the right side of the board.
  - E. Plug the hopper harness connector into the left side of the board
16. If the changer is permanently connected through a conduit, proceed to step #18.
17. Feed the AC line cord out the bottom or the back of the changer then perform the following.
  - A. Connect the AC line cord into the bottom of the main logic board.
  - B. Plug the male end into the AC wall outlet. ***Do not use an extension cord unless allowed by the building electrical code.***
  - C. **Important:** Attach the line cord clamp to the line cord. Verify it is at the right length and that the line cord is not rubbing against any sharp edges or is being strained in any way. Then mount the line cord clamp to the studs at the hole. Tighten securely. Installation is finished and you can proceed to the "Filling the Hopper" section.
18. In order to continue you will need to purchase electrical cable conduit, a standard 3-prong AC wall outlet and 12-gauge wire. We highly recommend HIRING a qualified electrician to perform the following!
  - A. Install the conduit box on the conduit entering the cabinet in the lower right side of the cabinet.

- B. Secure the 3 wires (hot, neutral, and ground) to the AC wall outlet and the ground wire should also be directly attached to the cabinet ground terminal.
  - C. Connect the AC line cord into the bottom of the main logic board.
  - D. Plug the male end into the AC outlet just installed.
  - E. Properly fold the line cord to avoid sharp corners and any other damage.
19. Proceed to the "Filling the Hopper" section.

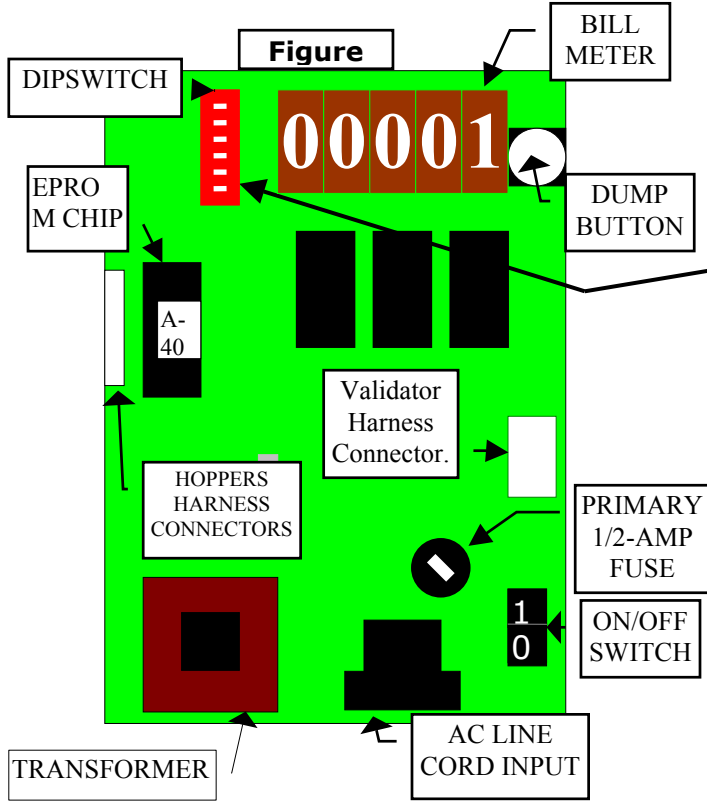

**FILLING THE HOPPER (S)**

When the hoppers have less than 80 - 100 coins left in it the red "Empty" LED will light on the front of the changer. If you have disconnected your LED make sure the orange wire is going to the terminal on the LED that has the red positive mark next to it. Whenever the "Empty" LED is "ON" the validator is disabled and it will no longer accept bills.

1. Turn OFF the power on the main logic board.
2. Pour the coins through the opening on the top. *There must be at least enough coins to cover the two gold plates at the bottom of the hopper. (Somewhere between 160 and 12,000 coins minimum to maximum.)*
3. Turn "ON" the power switch. The "Empty" LED is now off and the bill validator is ready to accept bills.

**USING THE DUMP MODE TO EMPTY THE HOPPER**

1. Open the cabinet door.
2. Turn OFF the POWER switch.
3. Place a suitable container in front of the hopper to catch the coins.
4. Press and hold the "DUMP" button on the upper left corner of the Main Logic Board. Turn ON the Power switch. The red LED on the main logic board will come on then go off. Once the red LED goes off, release the "DUMP" button. If it is not released within two seconds, the "DUMP" mode is canceled as a security feature. The hopper will dispense

coins until the POWER switch is turned OFF. If the Red LED on the Main Logic Board is not flashing 3-5 times per second the dump mode was not accessed. Please try again.

**THE DIP SWITCHES**

The AC8004 series changer is capable of dispensing from 0 to 31 coins per dollar. Setting the coins out per dollar is controlled by which Dipswitches turned "ON." (Refer to figure 1 for their location.) For example, switch #3 is "ON"; therefore the payout equals 4 coins per dollar.

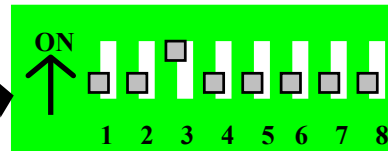

FIGURE 2  
 (THIS IS NOT THE DIPSWITCH BANK FOR SETTING THE BILL DENOMINATIONS.  
 (For those dip switches go to page 10.)

The following table shows how to set the dip switches to your desired payout.

<u>"ON"</u>	<u>COINS PER DOLLAR</u>
#1	1
#2	2
#3	4
#4	8
#5	16

If you want to dispense 10 dimes per dollar turn "ON" switches 2 and 4. (2 coins + 8 coins = 10 coins.)

If you want to dispense 20 nickels per dollar turn "ON" switches 3 and 5. (4 coins + 16 coins = 20 coins.)

DipSwitch #6 is for giving extra coins for every \$5.00 bill input. This is for a token bonus mode payout. If you are giving 4 coins per dollar, then 4 extra coins are given. If you are paying 5 tokens per dollar, 5 coins are given extra. This is the only bonus mode available in the AC8004 series changer.

**EXAMPLE:** With dipswitch #6 "ON" and a 4 coin per dollar payout this will be the amount dispensed for each bill denomination.

\$1.00 bill	4 coins
\$5.00 bill	24 coins
\$10.00 bill	48 coins
\$20.00 bill	96 coins

*Dip switches 7 and 8 should remain in the "OFF" position.*

## FUSE

**High voltage fuse:** This is the primary transformer AC fuse for the main logic board and the validator. Any direct short of the Transformer or validator will cause this fuse to blow. Replace this fuse with a 1-amp GDC fuse only. **REPLACING THIS FUSE WITH ANYTHING OTHER THAN A 1/2- AMP MAY RESULT IN A FIRE OR AN UNSAFE WORKING CONDITION!!** (See fig. 1 for location of this fuse.)

### Functional Description of the Series AC8004 Changer

*To follow along with this walk-through of your changer, fill the hopper with coins and turn the changer on.*

1. When power is applied the validator will cycle twice, the out-of-service LED flashes then goes out. The green LED on the main logic board comes on steady, and the red LED on the main logic board will light then go off then flicker on once per second in the standby mode.
2. During the power-up mode the main logic board relay clicks twice enabling power (120vac) to the validator. When this relay is not enabled it routes 12vdc ground to the out-of-service LED. Without power to the validator the changer cannot accept bills. Since we are not in the error mode, the red LED on the validator logic board is on steady.
3. When a bill is inserted into the validator bill slot, the bill will be pulled inside. The validator then compares what the bill looks like to its memory. After the bill is validated it grounds the 5vdc lines causing a pulse along the yellow and blue validator harness wires to pins 5 and 6 of the main logic board. Each pulse stands for the amount of the denomination validated. (i.e. 1 pulse for \$1, 5 pulses for \$5).
4. The 5vdc pulse then travels from pins 5 and 6 to the EPROM chip (MONO A-40) EPROM sends a 12vdc pulse to the meter chip (U5) out pins #21 & 22 (one pulse per denomination validated). The EPROM also multiplies the bill pulse by the DipSwitch settings (The EPROM reads the DipSwitch settings during the power up mode and stores them into memory.)
5. The EPROM then sends the hopper pulses out pin #23 to pins 6 and 7 of the red 12-pin hopper plug. These pulses travel through the purple and brown wires of the hopper wire harness to the hopper pins 8 and 12.
6. The hopper turns itself on with the first hopper pulse. The hopper counts the hopper pulses sent from the EPROM chip on IN3 (pin 12) while dispensing the coins at the same time. When the amount of hopper pulses in equals the coins dispensed through the coin counting optical sensor the hopper turns itself off.
7. The Changer returns to the standby mode with the red LED flashing once per second until another bill is inserted.

**NOTE: THE METER ON THE MAIN LOGIC BOARD CANNOT BE RESET TO ZERO!!!**

### Functional Descriptions of Out-of-Service Conditions

*Out-of-Service conditions occur for the Series AC8004 changer for the following reasons; low coins, hopper fault error, validator fault, or a blown fuse.*

1. **Blown Fuse:** a AC power spike in line voltage or a bad transformer on the main logic board can cause A blown fuse on the main logic board. If either fuse blows the indication is the green LED on the main logic board will not light.

- A. Replace the fuse. If the green LED now lights then there was a spike.
- B. If it does not and the fuse blows again the power transformer is shorted. To test the transformer use a voltmeter set for ohms and measure across the primary (40-ohms) and the secondary (1.5-ohms).
2. **Hopper Fault:** A hopper fault can either be a jammed hopper, a blocked coin counting optic or a bad hopper logic board.
  - A. Indications for a jammed hopper are the changer accepts bills, the meter counts up, but nothing or not enough coins are paid out.
    1. After 2 minutes the “Empty” LED on the outside of the cabinet starts to blink once a second and the validator is shut off.
    2. At this point the three options open are to attempt repair on your own, call your distributor, or return the hopper to American Changer.
  - B. Indications for a blocked coin optic or bad hopper logic board are the out-of-service LED on the outside of the changer is lit and the red LED on the main logic board is lit and flickers off once per second.
    1. If two of the 3 green LED’s on hopper logic board are lit then the hopper logic board is bad.
    2. If there is a coin or foreign object caught in the coin exit window LED’s #1 and #3 will be lit on the hopper logic board instead of LED’s #1 and #2.
      - a. Take off the side of the hopper with 5 Philips screws. Pull up on the exit window logic board and look for the jammed item.
      - b. Ensure you have the pins aligned before reconnecting logic board.
3. **Validator Fault:** When a validator fault occurs the validator’s EPROM shuts down the validator and flashes an error code via the red LED on the validator logic board. When there is no error this LED is on steady. The validator only gives bill pulses to the main logic board so the main board never knows if the validator isn’t functioning. Therefore the out-of-service-LED will not light. (See page 6 for validator error codes.)
4. **Low Coins:** The low coin condition is probably the most common fault. The EPROM on the main logic board is constantly checking for low coins in the hopper. This is done with a low current 5vdc signal on pin #3 of the hopper output connector. The voltage then travels down the hopper wire harness on the white wire to pin #7 of hopper plug. The signal is applied to one of the gold low contact plates at the bottom of the hopper. The 5v travels through the coins through the other contact gold plate to hopper pin #2. It then goes through the black wire in the hopper harness to pin #10 on the main logic board. Any interruption of more than 1/2 a second will cause an out-of-service condition.
  - A. Clean the bottom gold plates of the hopper with steel wool or a fine sandpaper. Refill the hopper and try again.
  - B. Check continuity, (0 ohms) resistance, from pins 3 (white) and 10 (black) of the red hopper harness. Make sure the hopper full and the changer turned off.
    1. If the continuity is 0 ohms, replace the main logic board.



- C. Pull the hopper out of the changer, then look at the 12 pin black male connector that sticks out of the hopper. Place the continuity checker's leads on pins 2 & 7.
  1. If the continuity is 0 ohms, replace the hopper plate or adjust the hopper plate's female socket's pins so that they are not so spread out.
  2. If the continuity is infinity, then replace the hopper.

### Indicator Lights

#### Main Logic Board:

1. Green LED on: AC power applied to the logic board. All fuses are good.

#### Validator logic board:

1. Red LED
  - A. On Steady - Standby Mode, waiting for bill insertion.
  - B. Flashing - Error mode, go to page for error code information.
- C. Off - The changer "Empty" LED is lit.

### Coin Control Hopper MKIV

Three green LED indicators are fitted on the hopper and are visible in the section where the coins exit the hopper. From left to right these are designated as follows:

1. Logic power supply on (12 & 24vdc present).
2. Security optical obstruction indicator -. Should be "on" when unit is OK.
3. Output indicator, indicates coin passing photo-sensor. This is the optical sensor the coin will obstruct on its way out of the hopper. For normal operation LED # 3 will be off until coins are dispensed.

### HOPPER ERROR CODES

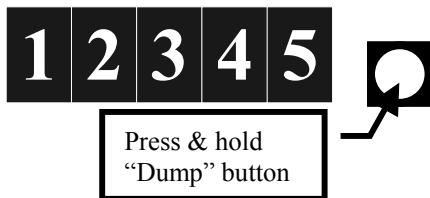

With the digital display the logic board is now able to convey exactly why the "Empty" LED is lit. Press the "Dump" button **while the "Empty" LED is lit**. On the Light-up display the meter count will go away while holding the button down. These are the error code definitions:

- 1---- - Hopper was shut down completely.
- 2--- - Hopper Exit Window LED is blocked.
- 3-- - Low Coin Failure.
- 23-- - Hopper is not Plugged into the Hopper Harness.
- 4- - Hopper is Jammed.
- 5 - Hopper Overpaid 2 Coins and was shut down.

Refer to the Troubleshooting section of this manual to repair these failures.

### Coin/Token Sizes

The hopper will automatically adjust to dispense coins/tokens in size from 20-30 mm in diameter and 1.25 - 3.5 mm in thickness.

There is an option available to dispense smaller coins.

A nickel is approximately 21 mm, a quarter is approximately 25mm. A Susan B. Anthony is 28mm

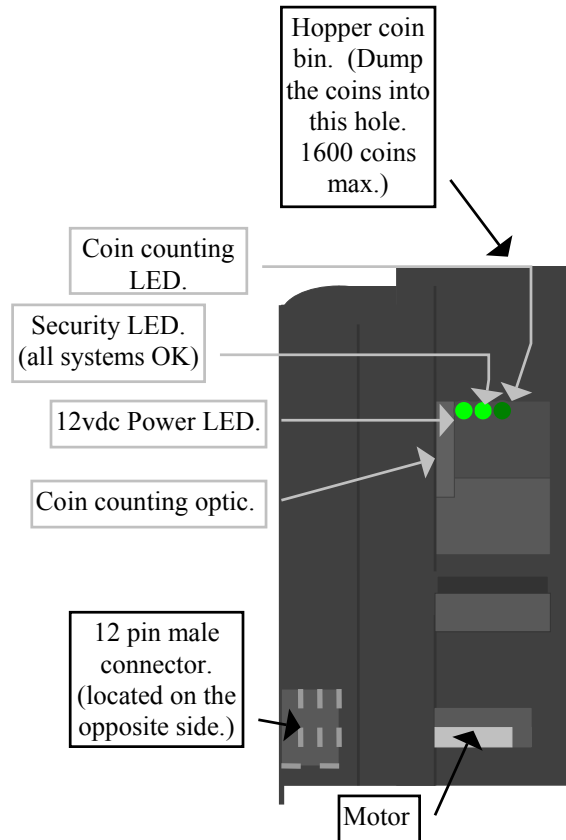

### WIRE HARNESS COLOR AND DEFINITIONS

#### Validator harness:

- Red - Switched Hot 120VAC.
- White - Neutral 120VAC.
- Black - 120VAC Low current validator enable.
- Yellow - +5vdc credit pulse line.
- Blue - -5vdc credit pulse line.
- Orange - +12vdc Empty LED.
- Brown - -12vdc Empty LED.

#### Hopper Harness

- Gray - Coin counting optic status line.
- White - Low coin sense (+5vdc).
- Green - Coin counting optic pay out feedback line.
- Yellow - Raw sensor output line.
- Purple - Hopper pay out line from main logic board (+),
- Brown - Hopper pay out line from main logic board (-).
- Red - +12vdc logic board supply voltage.
- Black(s) -12v, 24v low coin sense ground.
- Orange - +24vdc Motor supply voltage.

**MARS AE2601**

**120VAC \$1-\$20**



**BILL ACCEPTOR**

**MEI MARS AE2601  
VALIDATOR  
SECTION**

	<b>PAGE</b>
Removing the Bill Box	8
Clearing a bill jam	8
Setting the bill types accepted	9
Cleaning the Validator	10
Coupon Programming (Dip Switch)	11-12
Trouble Shooting & Trouble Codes	13

## Removing the bill box

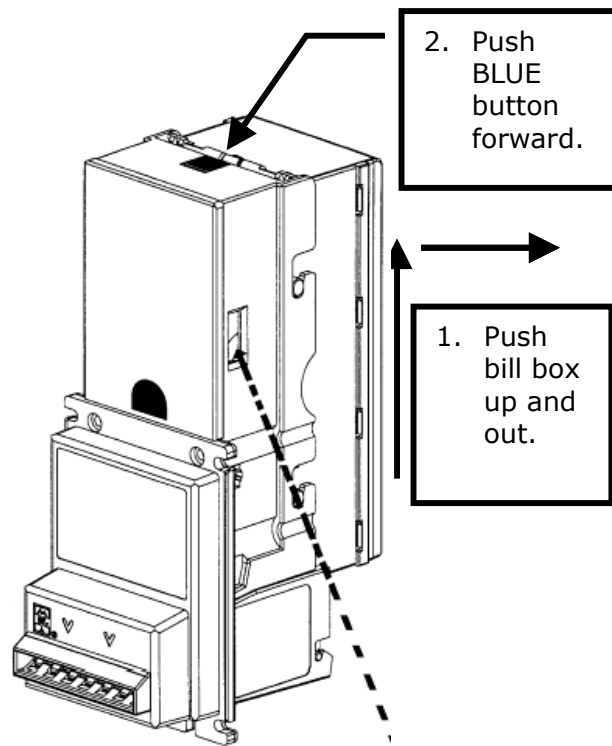

---

## Clearing A Bill Jam

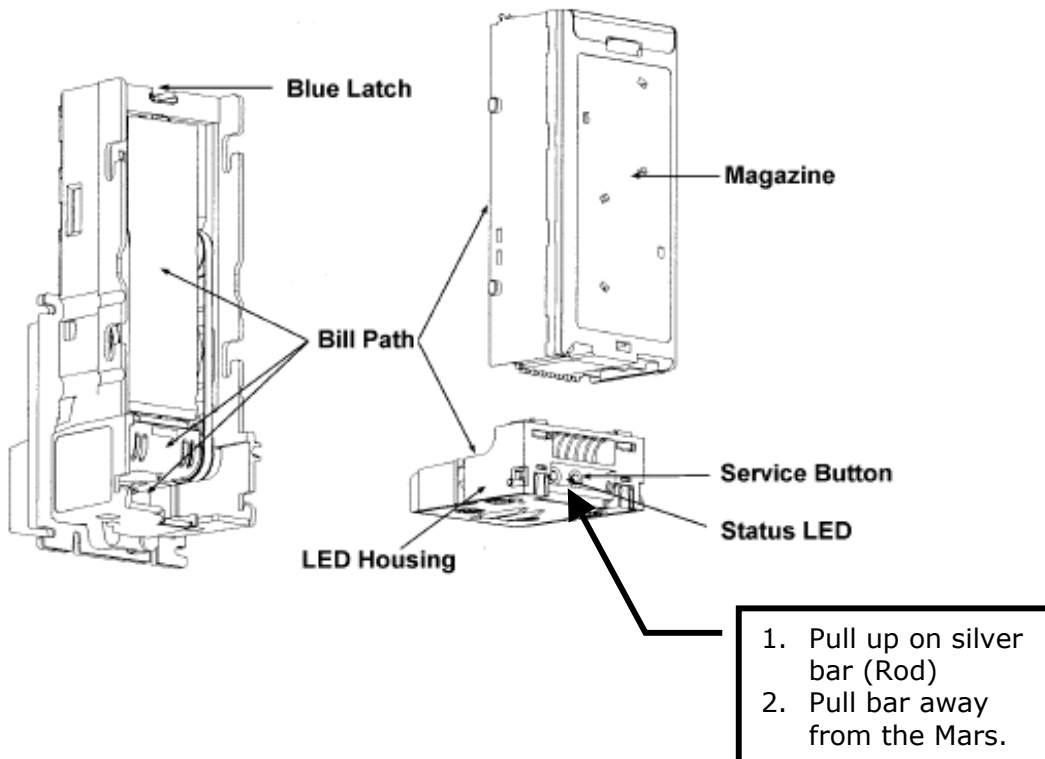

## Setting the Dip Switches

			Factory Default
Switch 1	Switch 2		
ON	OFF	1 Way Bill Acceptance	
OFF	ON	2 Way Bill Acceptance	
ON	ON	4 Way Bill Acceptance	X
<b>Switch 3*</b>			
OFF	High Security		X
ON	High Acceptance		
<b>Switch 4</b>			
ON	Rejects \$ 2 Bills		X
OFF	Accepts \$ 2 Bills		
<b>Switch 5</b>			
ON	Rejects \$20 Bills		
OFF	Accepts \$20 Bills		X
<b>Switch 6</b>			
ON	Always Enable		X
OFF	Harness Enable		
<b>Switch 7</b>			
ON	4 Pulse Per Dollar		
OFF	1 Pulse Per Dollar		X
<b>Switch 8**</b>			
ON	Vending Interfaces		
OFF	Gaming Interfaces		X
<p>* Switch 3 affects all denominations. See Coupon Configuration on page xx for individual acceptance/security enabling options.</p> <p>** The AE2600 defaults to short pulse.</p>			

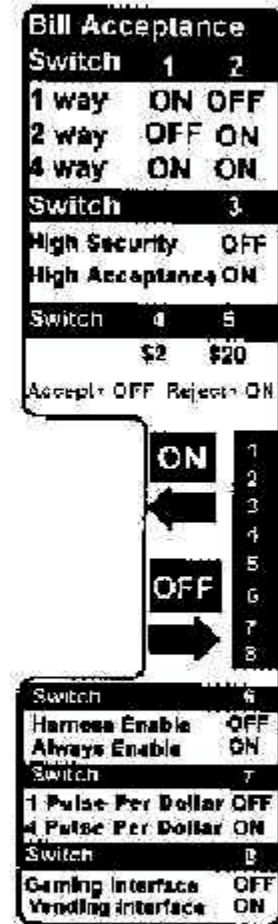



## Cleaning & Maintenance

### Cleaning

You can clean the bill acceptor while it is still mounted in the machine.

1. Remove power from the machine.
2. Unlatch the magazine by pushing the blue latch (located on the top of the unit) toward the front of the unit.
3. Unhook and remove the magazine by holding the latch and lifting up and then back on the magazine.
4. Unlatch the LED Housing by lifting up on the metal bar (located below the Status LED).
5. Remove the LED Housing by holding the metal bar and pulling back on the LED Housing.
6. Clean the bill path with a soft cloth. You may use mild, non-abrasive, non-petroleum based cleaners if sprayed on the cloth.

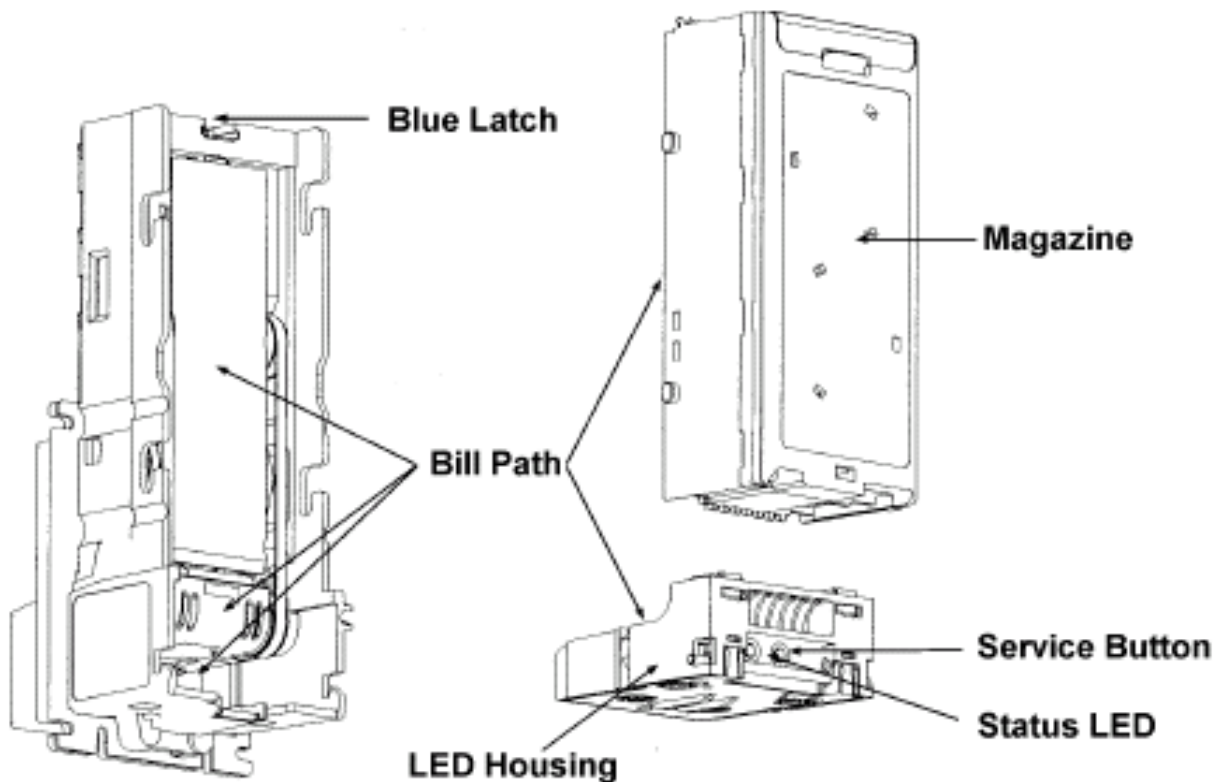

## Coupon Configuration

The AE2601 may be configured using a coupon. The coupon is included in the AE2601 Series Installation Guide. Carefully cut the coupon along the dotted-line edge to remove it from the installation guide. Copies of the original coupon may be produced with a standard, carbon-based, non-color copier. Cut copies to match the size of the original coupon.

**All option switches must be in the OFF position for the coupon selections to be active.**

The coupon selection will remain with the AE2601 until the unit is reprogrammed, even if power is removed.

When filling out the coupon, note the following:

Use only a #2 pencil to fill in the blocks

Fill in the entire block

Do not mark the coupon outside the blocks

or on the back of the coupon

Fill in **ONE** block for **EVERY** line

## Coupon Programming

1. Fill out the coupon using the table below.
2. Locate the service button on the back of the unit (refer to Figure 2).
3. Press the button once to enter the coupon setup mode. Pressing again will exit the mode. The unit will automatically exit coupon setup mode upon acceptance of the coupon configuration.

The LED Status indicator (located to the left of the service button) will flash rapidly indicating that the unit is in coupon setup mode.

4. Insert the coupon marked-side up.

The AE2601 will pull the coupon in, read it, and then return it to the user.

A good coupon will be returned immediately. After the coupon is pulled from the bill acceptor mouth, the unit will flash the Status LED ten times to confirm a good configuration.

A bad coupon will be held for ten seconds before being returned. This delay is to make you aware that there is a problem with the coupon. When the coupon is pulled from the bill acceptor mouth, the unit will flash the Status LED the number of times corresponding to the section of the coupon wherein a problem lies. For example, if

**THIS IS NOT A USABLE COUPON!**

**DO NOT COPY!!!**

**FIGURE 1**

**FIGURE 2**

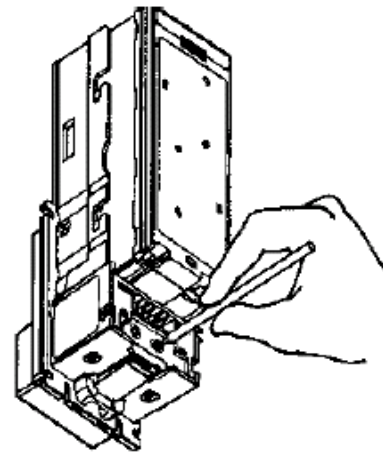

the problem is in section five, the LED will flash five times. Section numbers are located to the far right of each section on the coupon.

5. If the configuration is rejected, check the coupon and repeat the process.

Signal	Meaning	Solution
<b>LED ON</b>	Indicates that the unit is enabled and ready to accept a bill.	No action necessary.
<b>LED OFF</b>	Indicates that no power has been applied to the unit.	Check to ensure that power is applied.
<b>1 Flash</b>	Indicates that something is obstructing the bill path.	Remove the magazine and LED housing; inspect for foreign material.
<b>2 Flashes</b>	Indicates that the unit is not enabled.	Verify configuration. Check the coin tube levels in the coin changer. Check the option switches in the coin changer. Note: Many machines disable the bill acceptor if the machine door is open and the door switch is not activated or if the machine is out of product.
<b>3 Flashes</b>	Indicates that the bill path needs cleaning for optimum performance.	Remove the magazine and LED housing and follow cleaning instructions (page 22) to clean the bill path.
<b>4 Flashes</b>	Indicates that something is obstructing the bill path.	Remove the LED housing and look at the bill path on the housing and inside the unit for foreign material; clean as necessary.
<b>5 Flashes</b>	Indicates that the magazine is removed (the unit will not accept without the magazine attached).	Reinstall the magazine.
<b>Continuous Slow</b>	Unit is defective.	Replace the unit.
<b>Continuous Fast</b>	The magazine is full of money.	Remove the money from the magazine.

## Trouble Codes

### Status LED

A Status LED provides assistance in diagnosing the condition of the Series AE2600. The following is a description of the LED codes, their meanings, and suggested remedial actions.

**LED ON** - Indicates that the unit is enabled and ready to accept a bill.  
*No action is necessary.*

**LED OFF** - Indicates that no power has been applied to the unit.  
*Check to ensure that power is applied.*

**1 Flash** - Indicates that something is obstructing the bill path.  
*Remove the magazine and LED housing. Inspect for foreign material.*

**2 Flashes** - Indicates that the unit is not enabled.  
*Verify configuration. Check the dipswitches.*

**3 Flashes** - Indicates that the bill path needs cleaning for optimum performance.  
*Remove the magazine and LED housing and follow cleaning instructions (page 29) to clean the bill path.*

**4 Flashes** - Indicates that something is obstructing the bill path.  
*Remove the LED housing and look at the bill path on the housing and inside the unit for foreign material; clean as necessary.*

**5 Flashes** - Indicates that the magazine is removed (the unit will not accept without the magazine attached).  
*Reinstall the magazine.*

**Continuous Slow** - Unit is defective. *Replace the unit.*

**Continuous Fast** - The magazine is full of money.  
*Remove the money from the magazine*

# MAG BILL ACCEPTOR

Operation and Service Manual



## COINCO MAG50B VALIDATOR SECTION

	<b>PAGE</b>
Removing the Bill Box	14
Clearing a bill jam	14
Setting the bill types accepted	15
Cleaning the sensors	16
Cleaning a salted unit	17
Replacing the belts	18



### Removing the bill box.

To remove the 1000 bill stacker from the CoinCo validator follow the picture below.

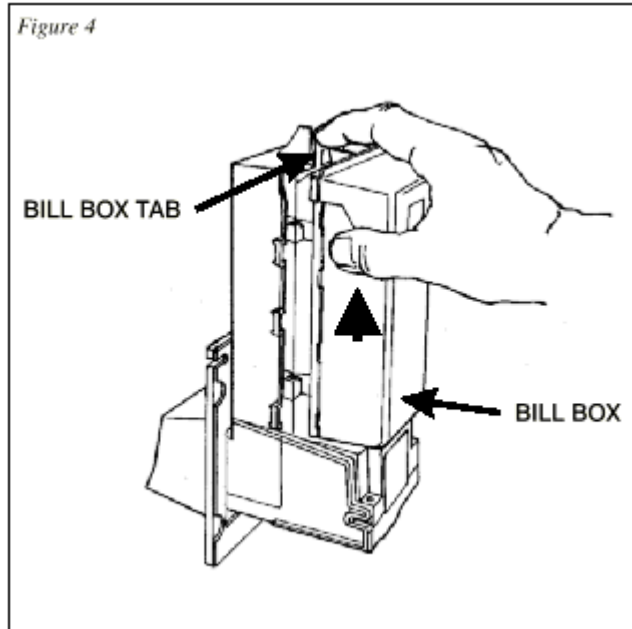

### REMOVING A BILL JAM

From time to time a foreign object or ripped bill will become caught in the validator. Follow the picture below to remove the item.

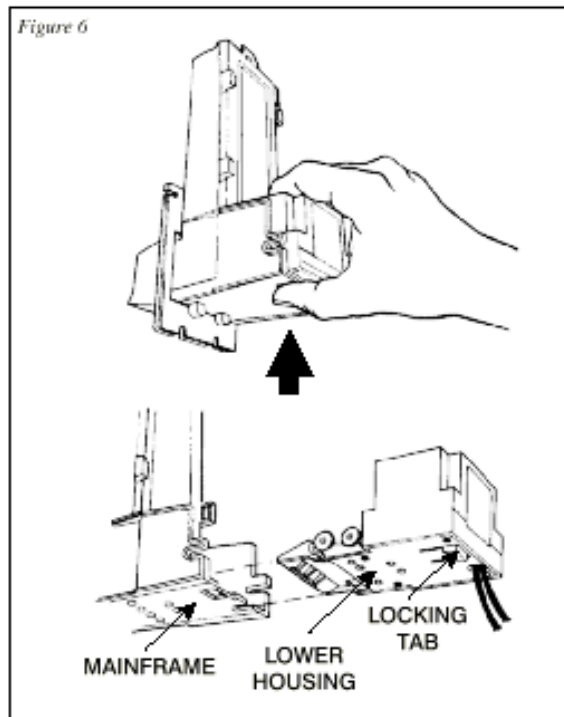



# SETTING THE BILL ACCEPT DIP SWITCHES

Figure 1

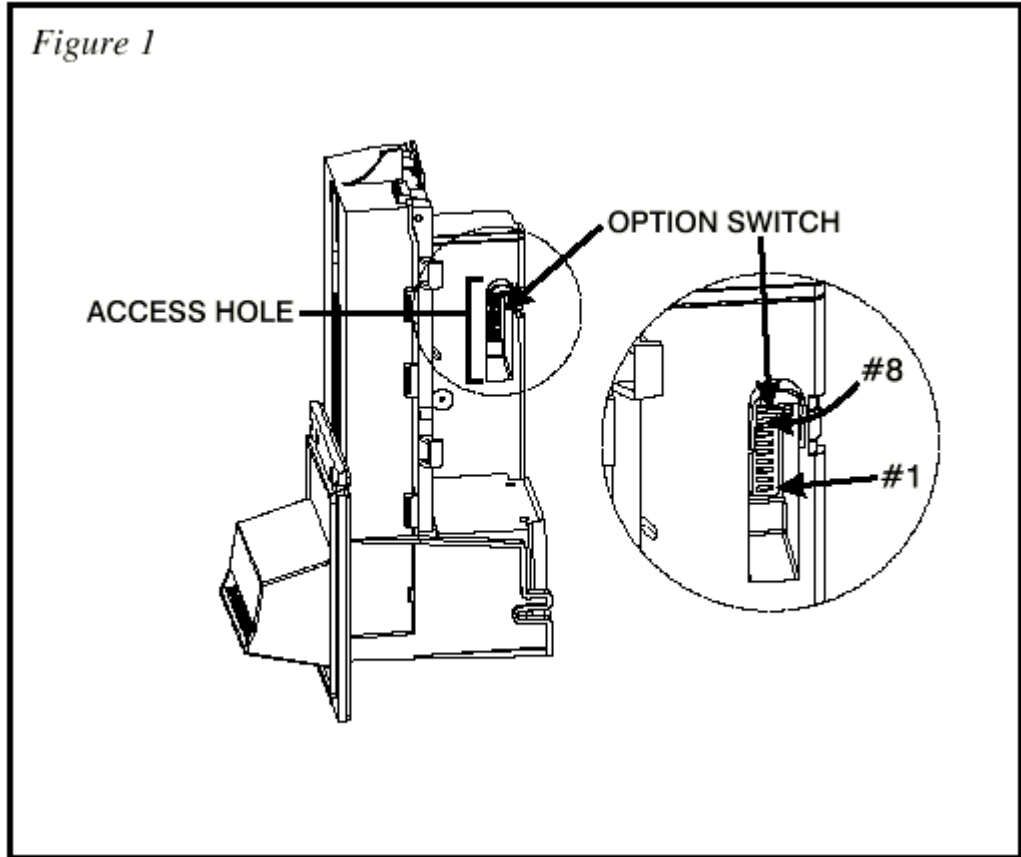
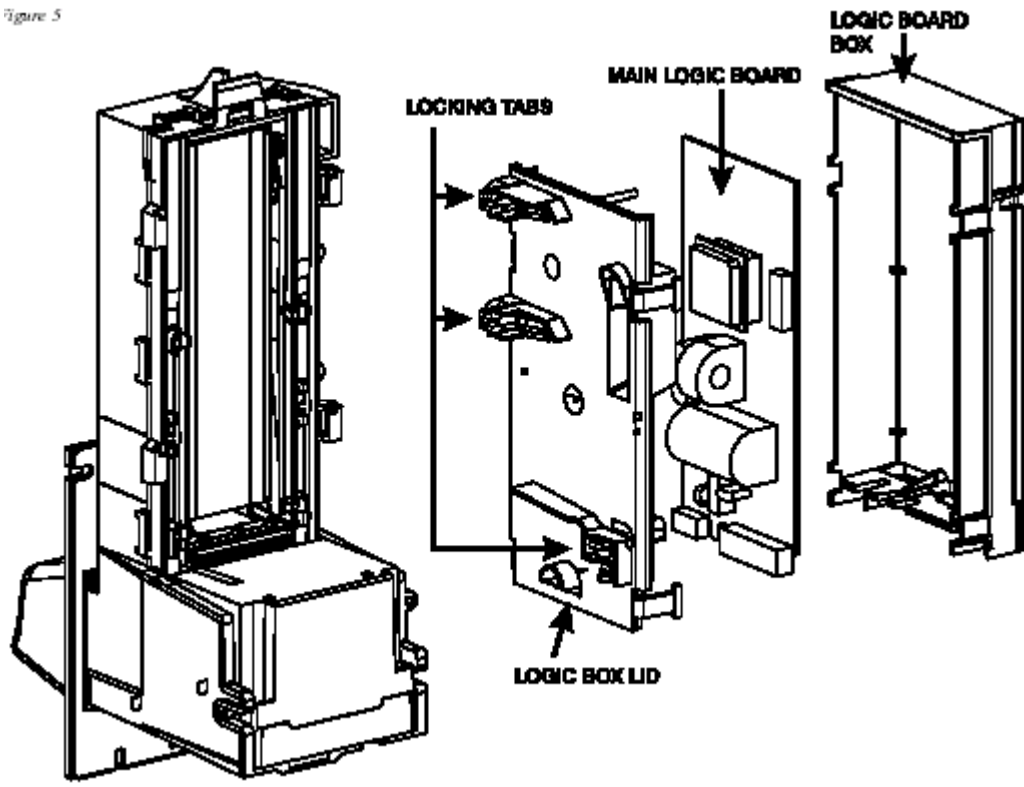
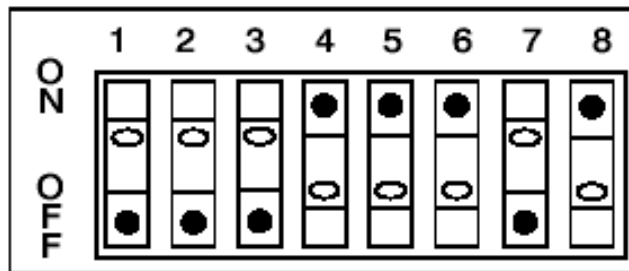

Figure 5



SWITCH	ON	OFF
1	High Security	Standard Acceptance
2	Accepts bills in one directions only (face up, green seal first)	Accepts bills in both directions (face up)
3	Standard credit pulse 150ms on 150ms off	Short credit pulse 50 ms on 50 ms off
4	\$20 Accept	\$20 Reject
5	\$10 Accept	\$10 Reject
6	\$5 Accept	\$5 Reject
7	\$2 Accept	\$2 Reject
8	\$1 Accept	\$1 Reject



## CLEANING THE BILL VALIDATOR

Refer to the pictures and the procedure on the next page to clean the bill validator every 4-6 months.

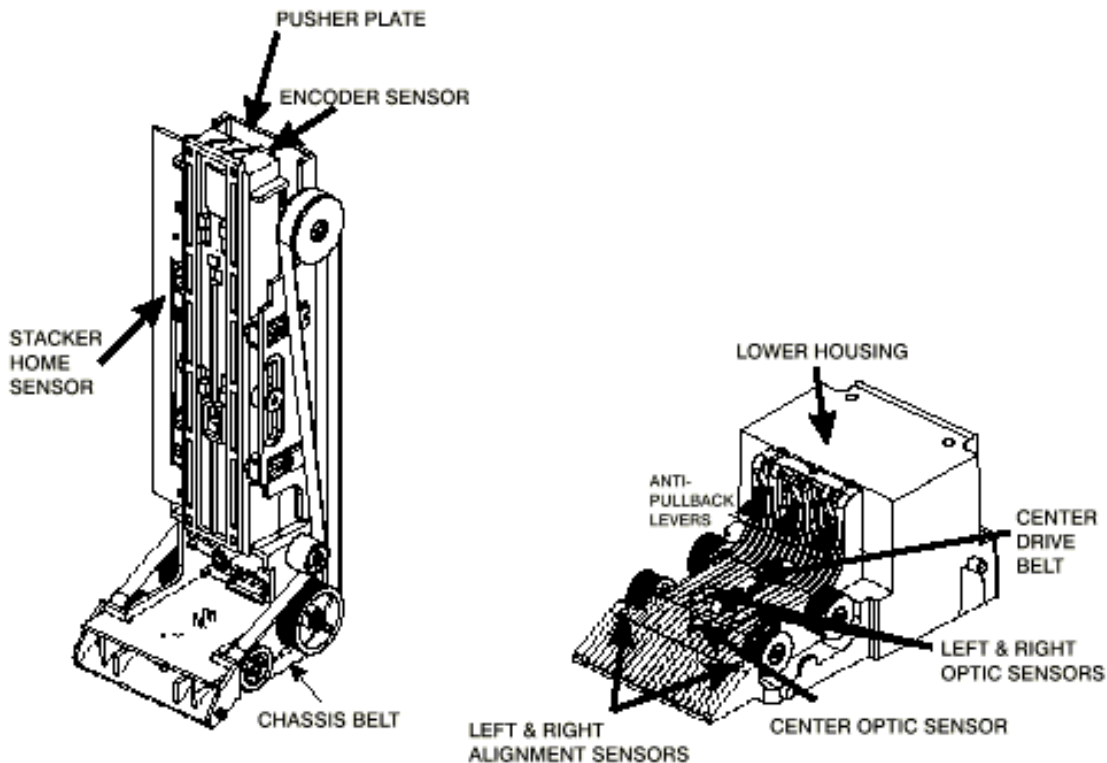

**MAGPRO CLEANING: IF ANY OF THESE PROCEDURES ARE PERFORMED TO YOUR VALIDATOR AFTER IT IS RETURNED UNDER A WARRANTY REPLACEMENT, YOU WILL BE SUBJECTED TO A \$65.00 LABOR FEE.**

**CLEANING AND MAINTENANCE:**

**Note:** Petroleum-based cleaners and freon-based propellants can damage plastic and some electronic components. Scouring pads and stiff brushes may harm the protective conformal coating on the circuit boards and can mar the plastic. These items should never be used when cleaning the MAGPRO bill acceptor.

**The MAGPRO should be cleaned every 7,000 bills or every 4 -6 months (or as needed, depending on the environmental conditions of the location). Dust can be removed with a soft brush or cloth or it can be blown out using compressed air.**

**Procedure:**

1. Disconnect power from the bill acceptor.
2. Remove the bill box and use a soft cloth to wipe the dust from around the intermediate frame and stacker plate.
3. Remove the lower track.
4. Using compressed air or a soft brush, blow or brush the dust off of the optic sensors and out of the recessed sensor openings.
5. Remove dust from around the belts and wheels on the lower housing and the sensors on the upper sensor board. The upper sensors are located directly above the lower housing sensor when the lower housing is installed.
6. The bill path can be cleaned to remove further dirt and oil using a soft cloth moistened with a mild soap and water solution.
7. Clean the magnetic head using a swab and isopropyl alcohol.
8. Once the lower housing is dry, place it back into the mainframe so that the tab on the bottom locks into place.
9. Blow the dust out of the encoder wheel and its sensors. (It may be necessary to extend the stacker plate to access the encoder wheel. Supplying power to the unit momentarily can do this, so that the stacker plate extends.)
10. Remove dust from the transport belt areas and from any other places of build up.
11. Remount the bill box.
12. Apply power and insert bills to verify that the unit is functions property.

**MAGPRO CLEANING PROCEDURE FOR SALT WATER POLLUTED UNITS:**

**Note:** Petroleum-based cleaners and freon-based propellants can damage plastic and some electronic components. Scouring pads and stiff brushes may harm the protective conformal coating on the circuit boards and can mar the plastic. These items should never be used when cleaning the BA30 bill acceptor.

**Procedure:**

1. Remove power from the bill acceptor.
2. Remove the bill acceptor from the vending machine.
3. Open the bill box lid and verify that the stacker plate is in the stand-by/home position. If it is not in the home position, apply power and observe that the stacker plate returns home.

**Warning:** If moisture is present, allow the unit to dry thoroughly before applying power to avoid possible shock hazard. If the stacker plate does not return to the home position, remove power and carefully remove the bill box to avoid damaging the bill box and/or stacker plate.

4. Remove the lower housing.

5. Remove the bottom cover from the lower housing.
6. Run hot water (1101/4-1401/4F) over the lower housing from the top and bottom. Using a soft brush, gently clean any residual salt. Use a soft absorbent cloth to clean any residue off the lower housing. If the transformer gets wet, allow the unit to dry for 24 hours before applying power.
7. Remove the front mask. Using hot water and a soft brush, clean the front mask, upper sensor board, main frame anti-pullback levers and position sensor mount.

*Caution: The motors are not protected from water, therefore the unit must be held in a manner that prevents water from running over the intermediate frame crossbar.*

8. Remove the position sensor cover on the crossbar and carefully lift the LED from its mount. (Early models only.)

*Caution: Protective coating on the LED leads should not be damaged. Clean all salt residue from the mount, sensor hole and detector area.*

*The detector can be seen through the sensor hole, and is located in the chassis. Replace the position sensor cover. (Early models only.)*

9. Verify that the anti-pullback levers move freely and that the spring returns them to their open position.
10. Allow the unit to dry thoroughly.
11. Clean the magnetic head using a swab and isopropyl alcohol.
12. Replace the front mask
13. Replace the lower housing cover.
14. Replace the lower housing into the main frame.
15. Remount the bill box.
16. Apply power and insert bills to verify that the unit is functioning properly.

**6 OR 7 ERROR CODE FLASHES**

*The cleaning procedure for this common occurrence is listed below. Just follow these steps.*

1. If this code has occurred on a new machine or one that the validators DIP switches were just changed, Ensure that all the white plugs on the side of the validator board away from the red LED are plugged in securely.
2. Remove the bill box.
3. Turn the Changer ON then OFF in an attempt to stop the metal push plate so that it COASTS into the fully outward position.
4. Using an air compressor or a can of compressed air blow out the area behind the push plate until it is completely free of all dust and lint.
5. Turn the changer power back on so that the push plate returns to the inward position. If the same error code persists, repeat steps 1 - 3 concentrating on the top center area behind the plate.
6. Replace the bill box.

## REPLACING THE BELTS

Every 2-3 years the belts on the CoinCo will wear out. To replace them, remove the validator components down to the picture show. Refer to the parts diagram at the end of the manual for help getting to this point.

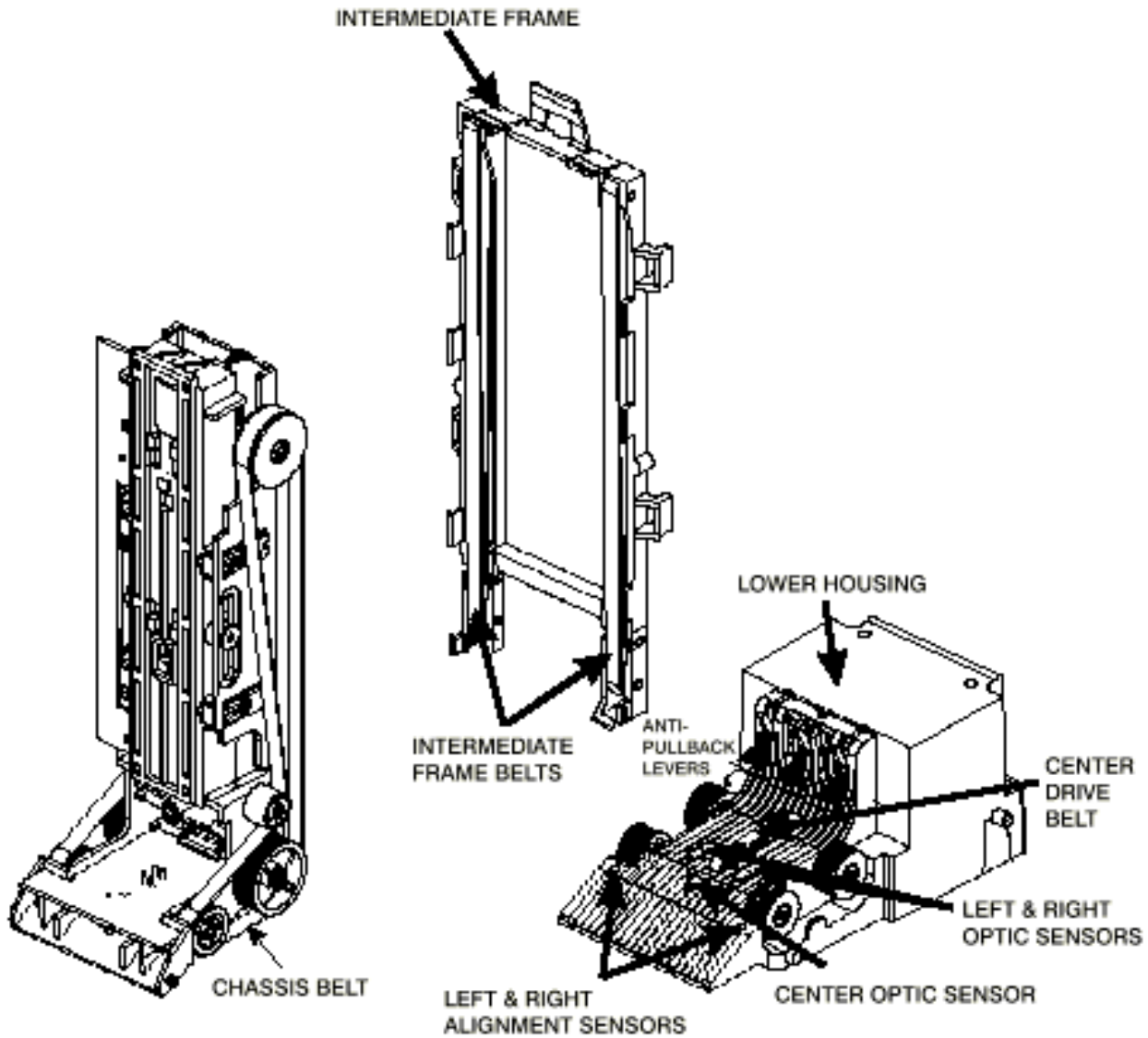

# MKIV UNIVERSAL HOPPER

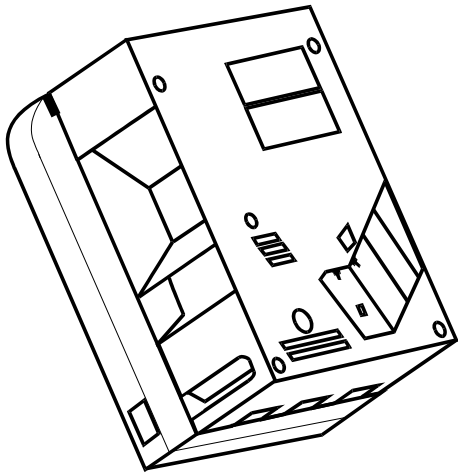

## SERVICE MANUAL

## INDEX

	PAGE
1. Coin box removal & reassembly	20-22
2. Exit window replacement	21
3. Logic board replacement	22
4. End plate removal	22
5. Track plate removal	23
5a. Track plate assembly.	23
5b. Track plate replacement	24
5c. Final drive gear replacement	24
6. Gearbox assembly	25
7. Motor replacement.	25

**To un-jam the hopper, refer to sections 4 – 5b, pages 22 –24.**



# 1. COIN BOX REMOVAL

1. Place the hopper in front of you as shown, (looking at the outside of the 'coin box').

Refer to FIG 1.

2. Remove the 2 locking nuts, which hold the 'low level sense plate' wires to the studs.
3. Remove the crimp & wire from the studs.

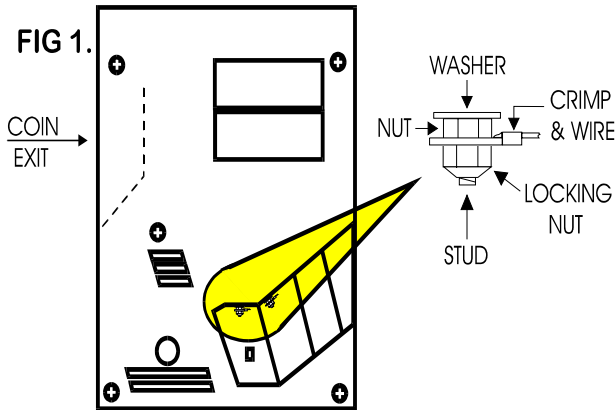

Refer to FIG 1a.

4. Remove the 5 screws indicated (B), which hold the 'coin box' to the 'center plate'.

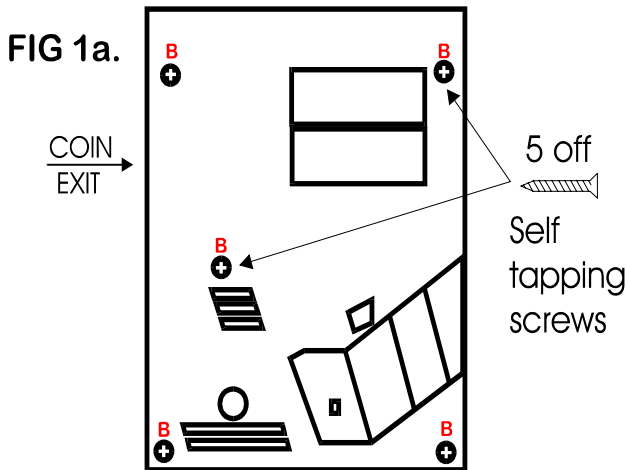

Refer to FIG 1b.

6. Gently lift the 'coin box' away from the rest of the hopper.

**NOTE:- The 'logic board' & 'stirrer' are located in the 'coin box'.**

7. As the 'coin box' is being removed, carefully slide the 'logic board' out. The stirrer may stay with the 'coin box' or fall onto the center plate.

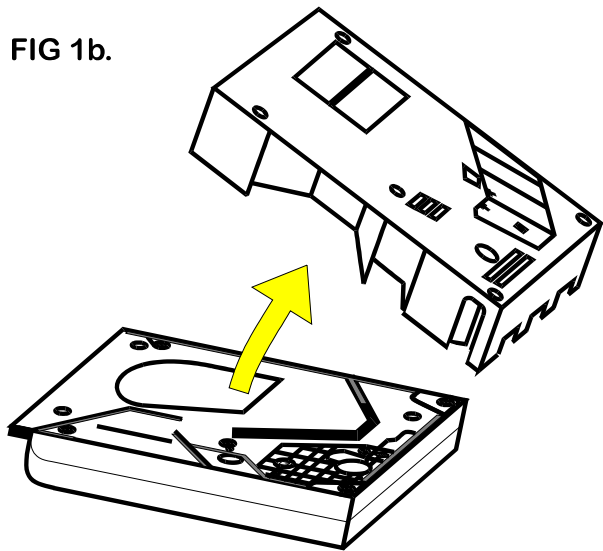

**ACCESS IS NOW AVAILABLE TO THE 'LOW LEVEL' SENSE PLATES, THE MAIN PCB, THE EXIT WINDOW, THE MOTOR TERMINALS & PART OF THE WIRING LOOM.**

## 1a. COIN BOX ASSEMBLY

1. Firstly, locate the 'stirrer' in the 'coin box as shown in FIG 12.

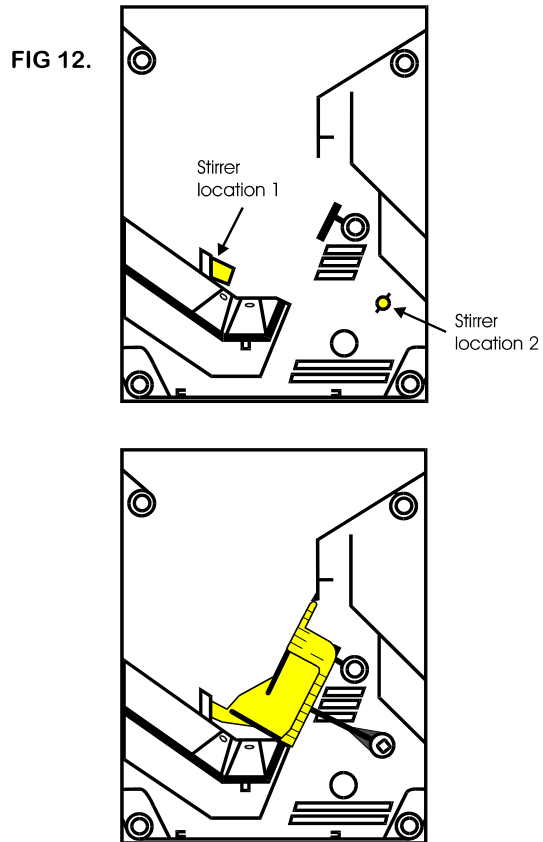

## COIN BOX ASSEMBLY (cont.)

- Line up the 'centre plate' & 'coin box' as shown below. FIG 12a.
- Route the ribbon cable as shown below.
- Fit the 'logic board' into slots shown below.
- Feed the level sense wires through the slot shown below.

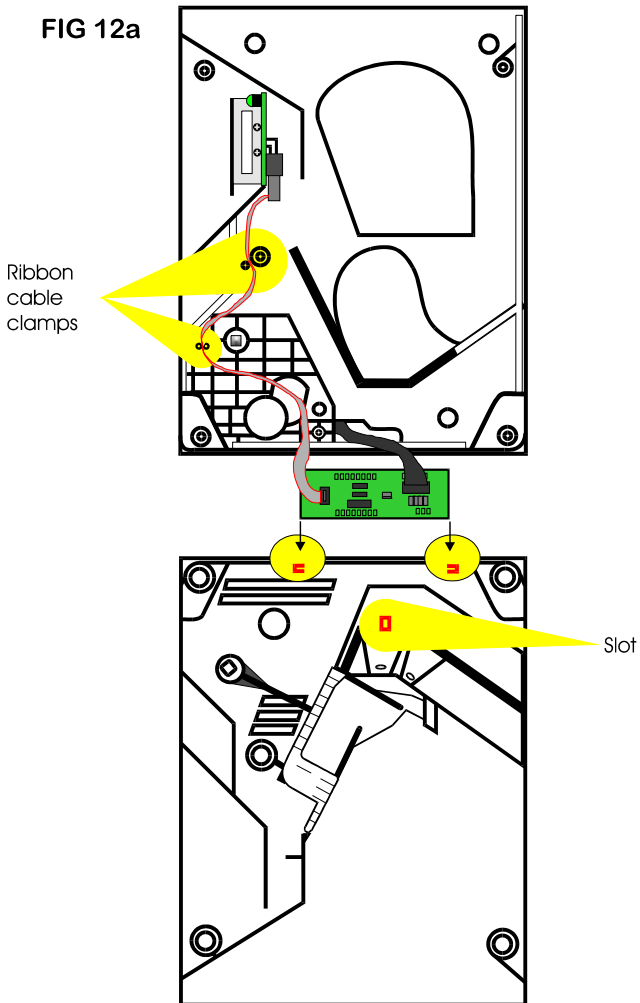

- Lift the 'centre plate' to meet the 'coin box'. FIG 12b & c.

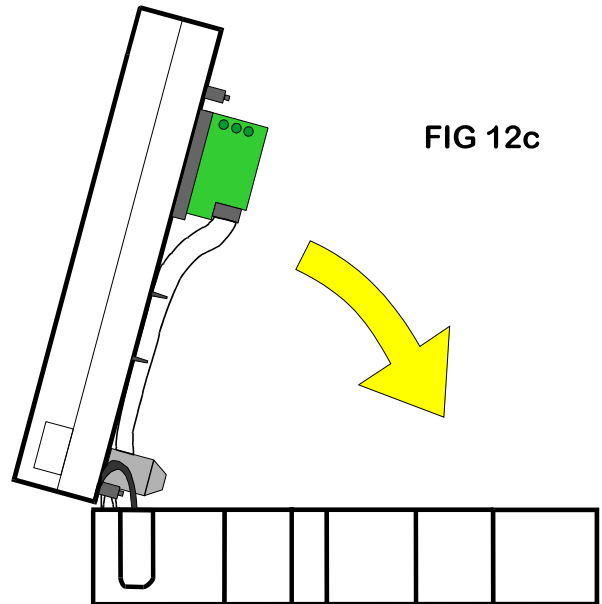
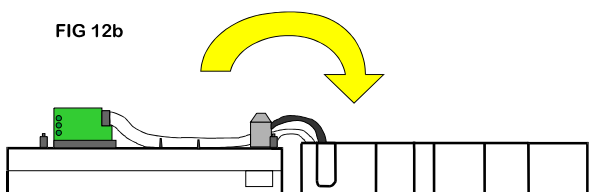

- Align the 'center plate' & 'coin box' & push together.
- Turn the hopper over & refit the screws.
- Refit the level sense wires.

## 2. EXIT WINDOW REPLACEMENT

- First, remove the 'coin box', section 1. **This will then enable access to the 'exit window'**
- Unscrew & remove the 2 fixing screws. FIG 4.
- Remove the 'exit window' from the 'center plate'.
- Unclip & remove the 10-way ribbon cable header.

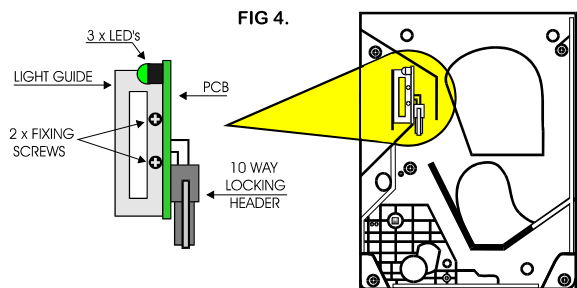

- To re-assemble, follow the above steps in reverse.

### 3. LOGIC BOARD REPLACEMENT

1. First, remove the 'coin box', section 1.

*This will then enable access to the 'logic board'.*

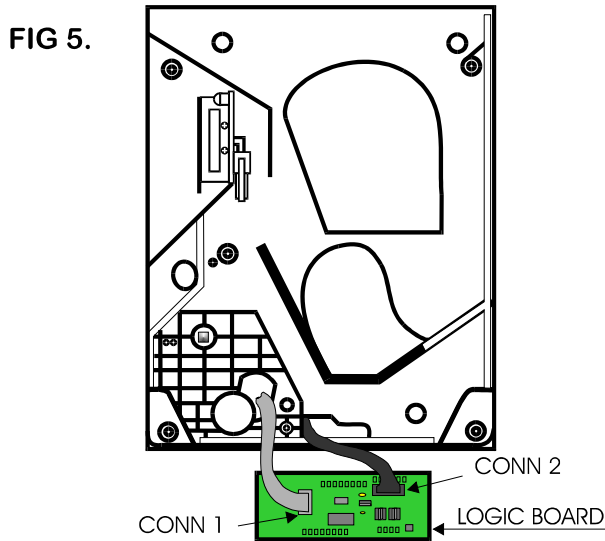

10-way ribbon IDC socket (CONN 1).

2. Move the two ejector arms at right angles to & away from the connector, if fitted.
3. This should release the socket from the header.
4. Clasp the connector between thumb & forefinger, pull away from pin header.
- 14-way crimp socket (CONN 2).
5. Gently, unclip the "friction lock" from the connector housing.
6. Clasp the connector between thumb & forefinger, pull away from pin header.
7. The Logic Board is now released.
8. To re-assemble, follow the above steps in reverse.

### 4. END PLATE REMOVAL

1. Place the hopper in front of you as shown, (looking at the outside of the 'end plate').

Refer to FIG 6.

2. Remove the 9 screws indicated (B), which hold the 'end plate' to the 'center plate'.
3. Locate the position of the 'connector blanking piece'.

4. Holding the 'connector blanking plate' gently lift the 'end plate' away from the rest of the hopper.

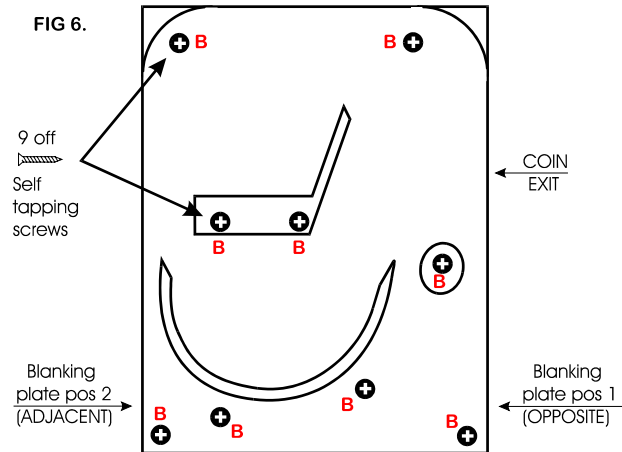

5. To re-assemble, follow the above steps in reverse.

### 5. TRACK PLATE REMOVAL

1. First, remove the 'end plate', section 6.

See FIG 7.

2. The 'elevator track' & 'final drive gear' can now be removed by lifting up & away from the 'center plate'.

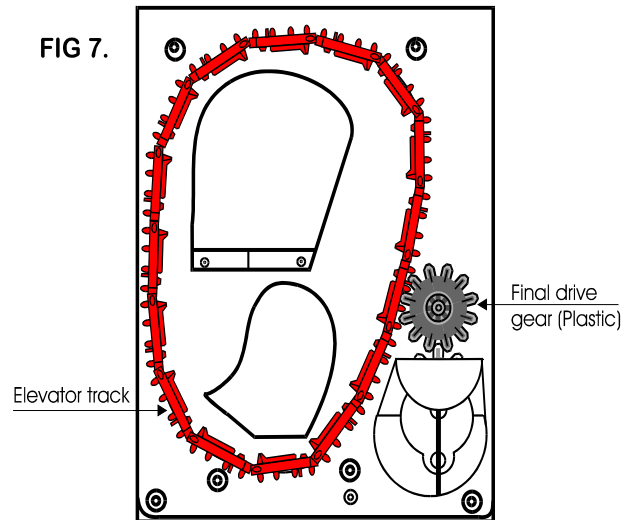

## 5a. TRACK PLATE ASSEMBLY

The following 3 sketches show how to take the 'track plate' apart.

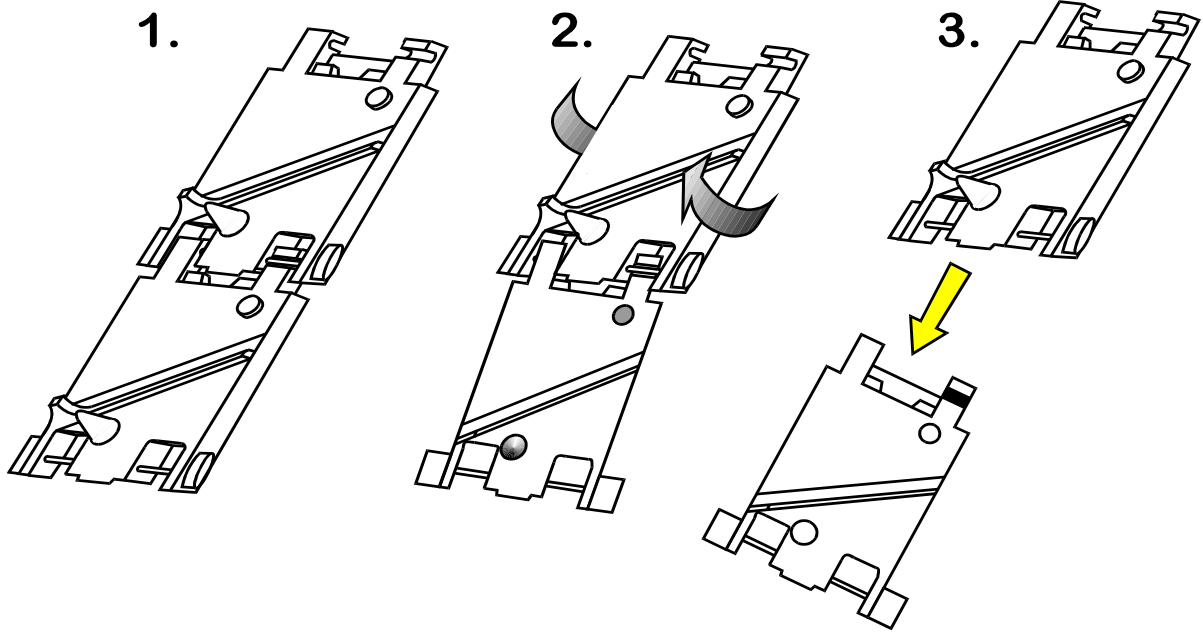

The following 3 sketches show how to assemble the 'track plate'.

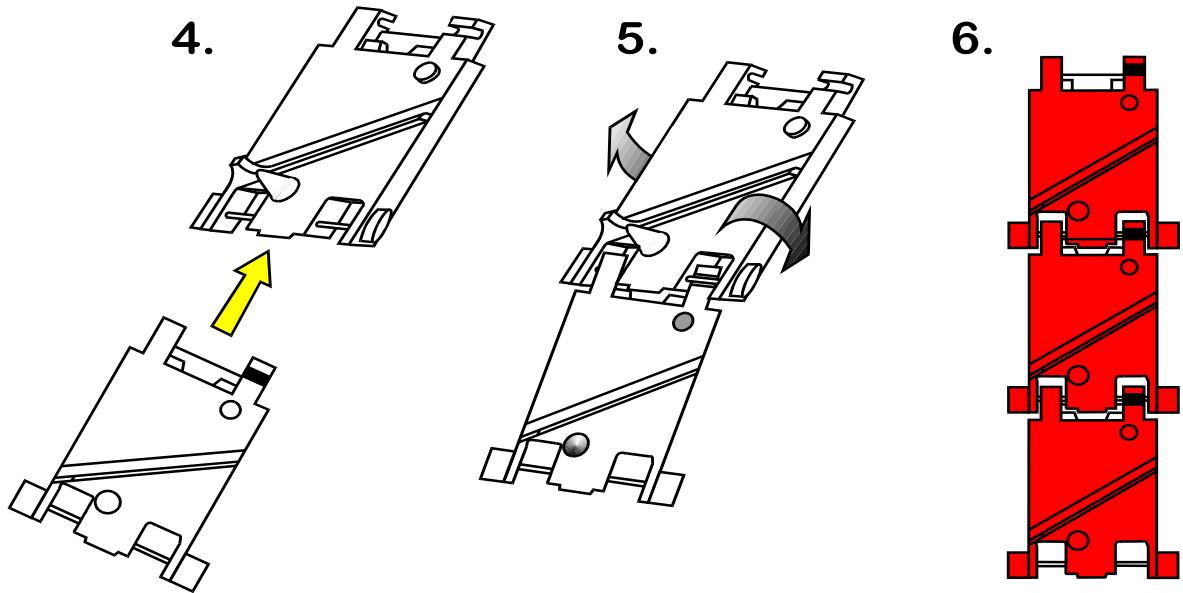

## 5b. TRACK PLATE REPLACEMENT

1. The gray shaded area, in FIG 7b, is the 'track plate' guide path.

FIG 7b.

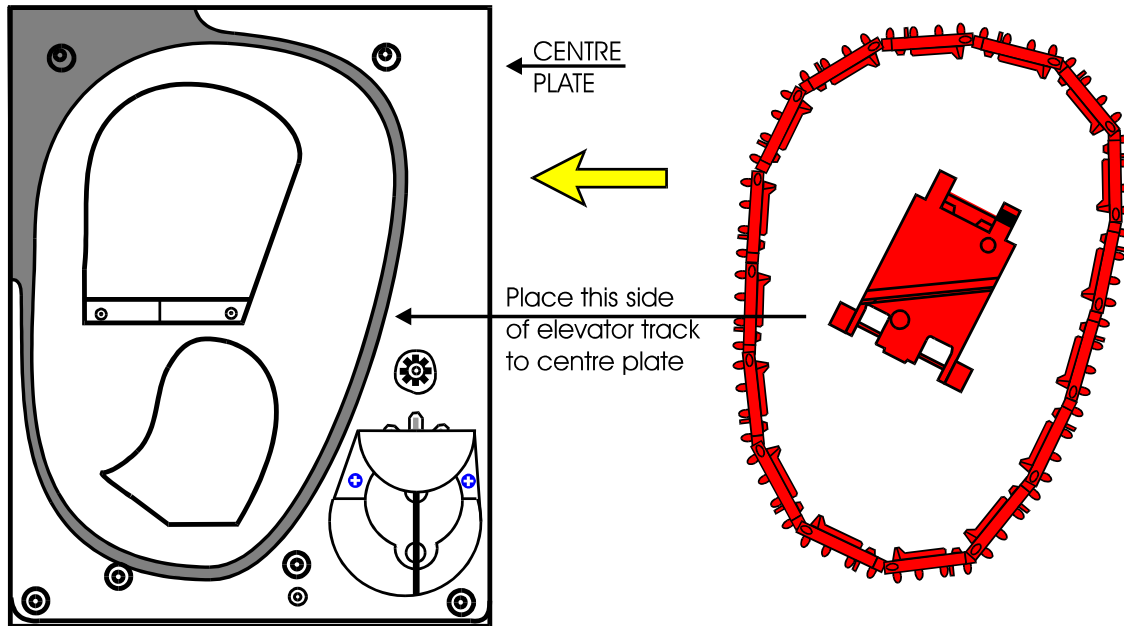

2. Once the 'track plate' is in position, turn the track through  $720^{\circ}$  to ensure it is seated in the guide path correctly.

## 5c. FINAL DRIVE GEAR REPLACEMENT

1. Once the 'elevator track' is in place, the 'final drive gear' can be fitted by placing the gear over its mounting spindle, while lining the teeth up with the secondary drive gear, adjust the 'elevator track' so that the gear falls into place. FIG 7c.
2. The end plate can now be re-fitted. See section 6.

FIG 7c.

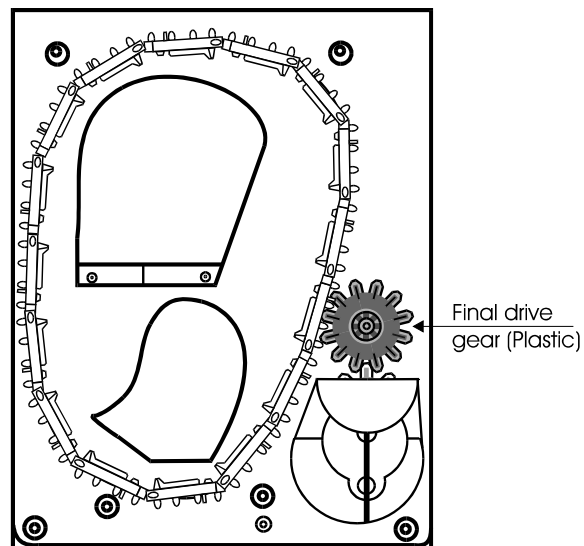



## 6. GEAR BOX ASSEMBLY

1. Remove the end plate. Section 6.
2. Remove the 'elevator track' & 'final drive gear'. Section 7.
3. Remove the gearbox cover. Section 8.

4. Remove the gears in the order as shown in FIG 9.

**Access to the motor fixing screws is now possible.**

5. To re-assemble, follow the above steps in reverse.

**FIG 9.**

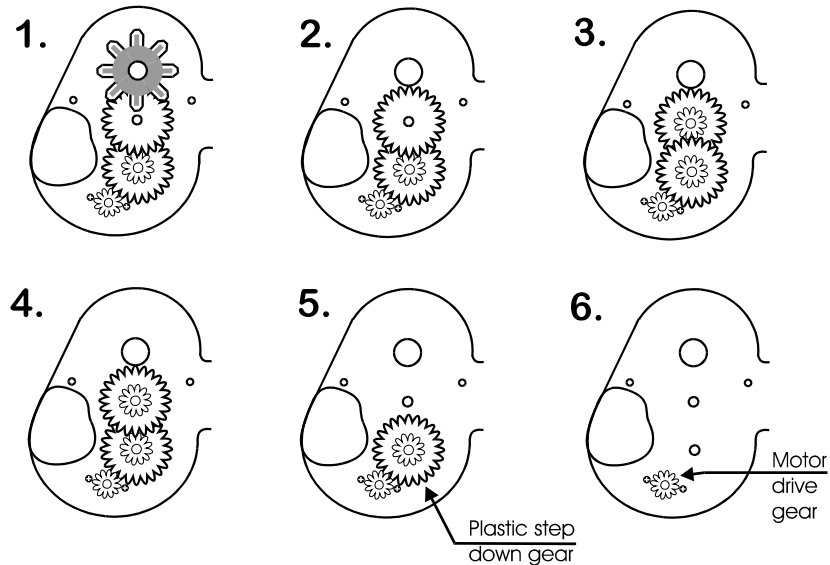

## 7. MOTOR REPLACEMENT

1. Remove the 'coin box'. Section 1.
2. Unsolder the red & black wires from the motor.

**NOTE: The black wire connects to the terminal marked with a RED dot.**

3. Remove the 'end plate'. Section 6.
4. Remove the 'track plate' & final drive gear. Section 7.
5. Remove the gearbox cover. Section 8.
6. Disassemble the gearbox. Section 9.
7. Unscrew the 2 motor fixing screws. FIG 10.
8. To re-assemble, follow the above steps in reverse.

**FIG 10**

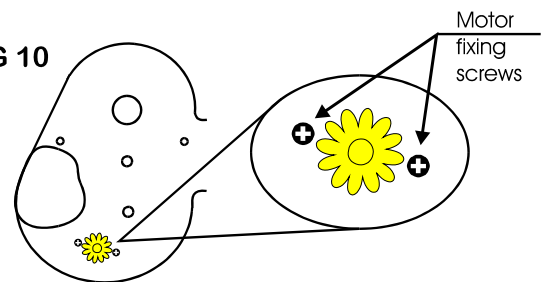

## Table of Contents

### SECTION A: SET-UP & INSTALLATION

Uncrating & Setup _____	3
<b>Mounting instructions</b> _____	3-4
Filling the Hopper _____	4
Using the Dump Mode _____	4
DIP Switches _____	4-5
Fuses _____	5
Functional Descriptions _____	5-6
Indicator Lights _____	6
Coin Control Hopper (Filling) _____	6
Wiring definitions _____	6
<b>HOPPER ERROR CODES</b> _____	6

### SECTION B: VALIDATOR INFORMATION

<b>Mars 2600 information</b> _____	7-12
CoinCo Validator information _____	13-18

### SECTION C: COIN HOPPER INFORMATION

Un-Jamming the hopper _____	21-23
Coin Mech Upgrade Info _____	26

### SECTION D: TROUBLESHOOTING INFORMATION

Troubleshooting Guide _____	27
Technical Flow Diagram _____	28-29

### SECTION E: PARTS LISTS

Cabinet Parts Breakdown _____	30
Parts Coin Control Hopper MKIV _____	31
Parts CoinCo Bill Validator _____	32-35
Parts Mars Bill Validator _____	36-38

### SECTION F: SERVICE CENTERS

CoinCo _____	39
Mars (MEI) _____	40-42

Rev. MONO A-40 Jan.'04

## Specifications

Operating voltage	120 VAC +10/-15 %
Power consumpt.(controller only, add hopper and validator)10w	
Operating temperature	32 - 130 degrees Fahrenheit
Interface to Hoppers	24vdc & 12vdc 1.5 amps max.
Interface to Validators	120vac .5 amps max.

### Warranty

CoinCo MAGPRO 00 BAB & MARS AE2601  
Validator is warranted for two years from date of purchase.

#### COVERED

¥ Defect in workmanship or material.

#### NOT COVERED

¥ Damage caused by physical abuse.

¥ Misapplication

¥ Vandalism

¥ End users attempt, on his own to repair item

¥ Cleaning maintenance

***It is the End User's responsibility to follow cleaning maintenance procedure outline on page 11. Any unit coming in for repair requiring only a cleaning will be charged a flat rate of \$65.00 plus shipping and handling.***

### Dispensing System and Logic Board

The dispenser and logic board is warranted for one year from date of purchase.

#### COVERED

¥ Defects caused by material or workmanship.

#### NOT COVERED

¥ Damage caused by physical abuse.

¥ Misapplication

¥ Vandalism

¥ End Users attempt, on his own to repair.

***A Return material authorization number (RMA #) must be obtained before returning a unit for repair. A copy of invoices must accompany any and all warrantee work***

## Attention Please:

American Changer is now building in a Surge Suppressor on every main logic board made after September 1<sup>st</sup>, 1998. This will help eliminate power related noise problems for our customers. It will not protect you from large voltage spikes or lightning strikes over 150VAC.

If this is a concern for your area of business, we recommend purchasing a surge protector locally

**NOTE: A POWER STRIP IS NOT A SURGE PROTECTOR.**

**Thank You,  
American Changer Corp**

## Condor Electronic Coin Mech. Programming

The next page will teach you how to program the Condor.

Program the NICKEL into the #1 slot and the DIME in the #2 slot.

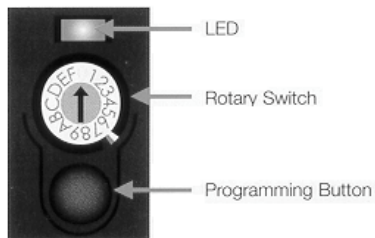

**To Teach and Run a coin or token into Condor follow this procedure:**



To start with the LED should be lit green and the rotary switch in position 0



Using a small flathead screwdriver turn the rotary switch to position 1 (or 1 to 6 for multi coin Condors) and press the programming button. The LED should change to red



Feed a selection of the coin to be taught into the acceptor until the LED begins to flash green (this typically happens after 4 coins). Press the programming button once more.



The LED should return to green. Turn the rotary switch back to 0. The acceptor is now ready to accept coins.

**The double logic board requires LEFT dipswitches #3-#5-#8 be set "ON" the logic board. ALL on the right dipswitches are "OFF"**

# TECHNICAL FLOW DIAGRAM AC8004

NOTE: Before starting this procedure ensure the changer is plugged in, the ON/OFF switch is on, **the hopper is full of coins, and all wire harnesses are connected securely and correctly.**  
*The wires exiting the red connectors should point away from the board!!*

**Start Here!**

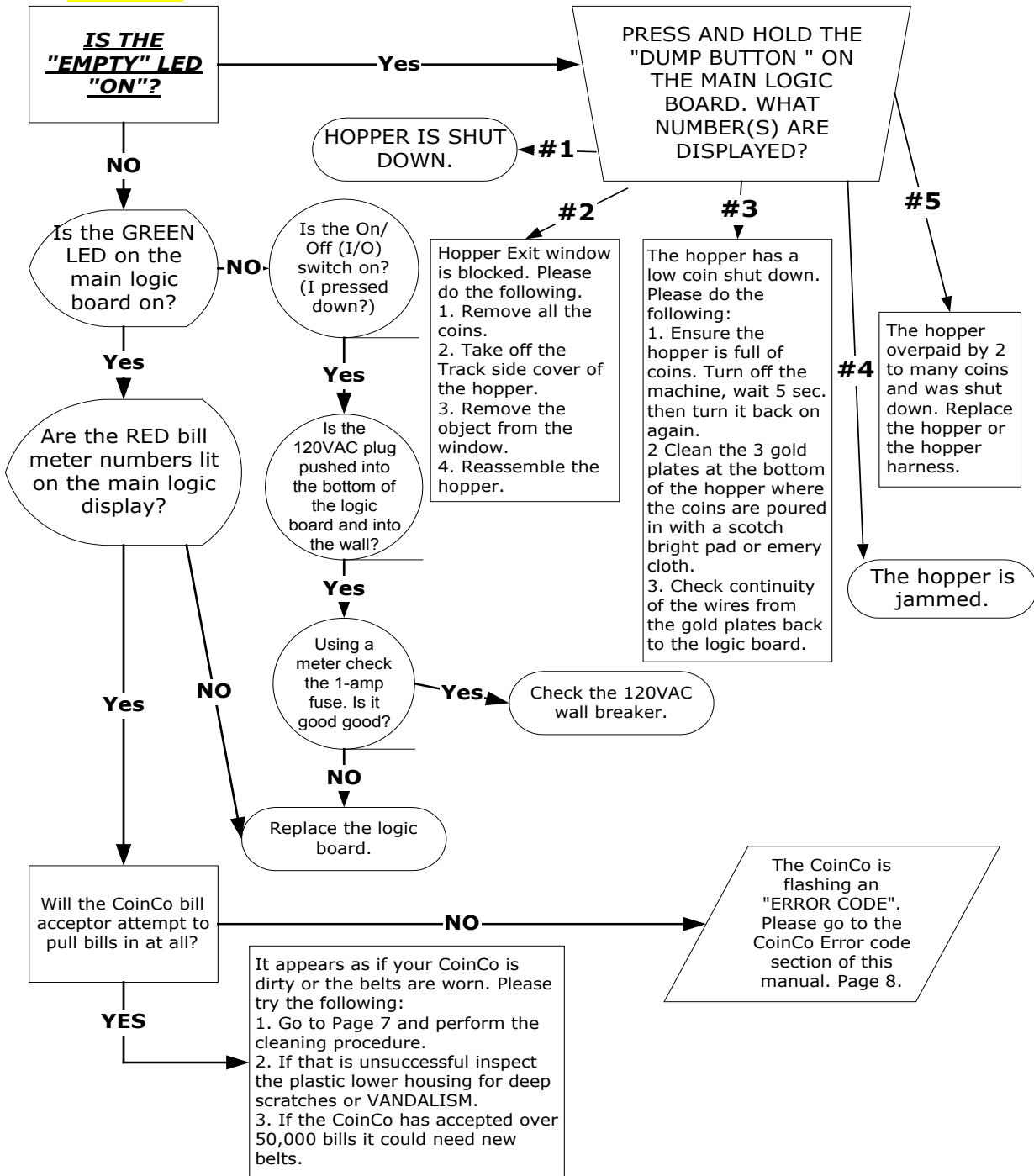

For a more detailed trouble shooting information proceed to the next section!  
**FOR TECHNICAL SERVICE OR TO OBTAIN A RETURN AUTHORIZATION NUMBER  
 CALL (888) 741-9840**

**ANY REPAIR RETURNED WITHOUT A RETURN AUTH. # WILL BE REFUSED!!**

## TROUBLESHOOTING GUIDE

TO USE THE TROUBLESHOOTING GUIDE, MATCH UP THE PROBLEM, THEN FOLLOW THE SOLUTION SUGGESTIONS. After every step re-try operating the changer to see if the problem has been solved.

<i>Problem:</i>	<i>Solution:</i>
A. <b>The changer is completely dead.</b> (The green LED on the main logic board is not lit.)	<ol style="list-style-type: none"> <li>1. Ensure the changer is plugged in.</li> <li>2. Ensure the on/off switch is rocked to the (1) position (down).</li> <li>3. Unplug the female end of the line cord from the main logic board AC connector and plug it in again tightly.</li> <li>4. Measure the AC voltage at the outlet or check the breaker/fuse box. You can also plug another item into the AC wall outlet to ensure there is power present at the outlet.</li> <li>5. Inspect the AC line cord for cuts or abrasions.</li> <li>6. Check both fuses on the Main Logic Board.</li> <li>7. Replace the main logic board.</li> <li>8. Replace the line cord.</li> </ol>
B. <b>The “Empty LED is lit.</b> When the red LED on the main logic board is observed, the LED is <b>flickering on briefly once per second.</b>	<ol style="list-style-type: none"> <li>1. Ensure the hopper is not out of coins. (There should be enough coins in the hopper to cover the gold low-level contact plates. These plates are located at the bottom of the hopper where you pour the coins.)</li> <li>2. Check the hopper wire harness that extends from the back of the plate that the hopper slides in and out on for chipped pieces or other damage. (Pay close attention to pins # 2 &amp; 7.)</li> <li>3. Clean the gold contact plates with steel wool.</li> <li>4. Replace the hopper.</li> <li>5. Replace the hopper wire harness.</li> </ol>
C. <b>The “Empty LED is lit.</b> When the red LED on the main logic board is observed, the LED is <b>on Steady.</b>	<ol style="list-style-type: none"> <li>1. Ensure the hopper is pushed into the hopper harness on the back of hopper plate tightly.</li> <li>2. Ensure that left and center green hopper LED’s are lit only. Not the left and right LED’s. If this is the case go to pg. 19 to un-jam the hopper exit window.</li> <li>3. Replace the hopper.</li> <li>4. Replace the hopper plate.</li> </ol>
D. The green LED on the main logic board is lit but the red LED never lights.	<ol style="list-style-type: none"> <li>1. Bad 5 or 12vdc regulator on the main logic board.</li> <li>2. The hopper is shorted.</li> <li>3. Replace main logic board.</li> <li>4. Replace hopper.</li> </ol>
E. The bill validator accepts and stacks the money but the bill meter never counts up.	<ol style="list-style-type: none"> <li>1. Check continuity and for pin damage to the blue and yellow wires on the validator harness.</li> <li>2. Replace the validator wire harness.</li> <li>3. Replace the validator.</li> </ol>
F. The bill validator stacks the bills, the meter counts up, but the hopper does not pay out.	<ol style="list-style-type: none"> <li>1. Ensure the dip switch settings are still correct. (#3 “ON” only)</li> <li>2. Check the continuity of the brown and purple wires on the hopper wire harness.</li> <li>3. The hopper is jammed. Go to pg.15 To unjam the hopper.</li> <li>4. Replace the hopper wire harness.</li> </ol>
G. Bill validator will not pull in the bill and the “Empty” LED is not lit.	<ol style="list-style-type: none"> <li>1. Ensure the orange wire going to the “Empty” LED is connected to the + or the terminal with the red mark by it.</li> <li>2. Check for 12vdc going to the orange and brown wires. If there is, replace the LED.</li> <li>3. Replace the main logic board.</li> <li>4. Replace the bill validator.</li> <li>5. Replace the validator wire harness.</li> </ol>

## TROUBLESHOOTING GUIDE

TO USE THE TROUBLESHOOTING GUIDE, MATCH UP THE PROBLEM, THEN FOLLOW THE SOLUTION SUGGESTIONS. After every step re-try operating the changer to see if the problem has been solved

<i><b>PROBLEM:</b></i>	<i><b>SOLUTION:</b></i>
H. The bill validator pulls in the bill slightly then rejects it.	<ol style="list-style-type: none"> <li>1. Clean the validator. (pg. 9)</li> <li>2. Remove the lower housing (pg. 11) of the bill validator. Ensure the center wheel spins freely. Push straight down on it slightly to loosen.</li> </ol>
I. The bill validators red status LED is on steady but it still will not accept the bill.	<ol style="list-style-type: none"> <li>1. Pull out the lower housing, see page , and look for something obstructing the bill path. (i.e. gum, paper, tickets, coins, etc.)</li> <li>2. Look inside the Plexiglas case on the side of the bill validator. Ensure that all the wire harness plugs are plugged firmly into their white female sockets.</li> </ol>
J. The red “empty” LED on the outside of the changer is on, the red status LED on the main logic board is flickering on and off normally, and the hopper is full of coins.	<ol style="list-style-type: none"> <li>1. Ensure the hopper is not out of coins. (There should be enough coins in the hopper to cover the gold low-level contact plates. These plates are located at the bottom of the hopper where you pour the coins.)</li> <li>2. Check the hopper wire harness that extends from the back of the plate that the hopper slides in and out on for chipped pieces or other damage. (Pay close attention to pins # 2 &amp; 7.)</li> <li>3. Clean the gold contact plates with steel wool.</li> <li>4. Replace the hopper.</li> <li>5. Replace the hopper wire harness.</li> </ol>
M. The “Empty” LED on the outside of the changer is flashing once per second.	<ol style="list-style-type: none"> <li>1. The hopper is jammed.</li> <li>2. The hopper failed to pay out what it was told.</li> <li>3. Service the hopper. (Pg. 21-24)</li> <li>4. Replace the hopper plate and harness.</li> </ol>
<b>FOR TECHNICAL SERVICE OR TO OBTAIN A RETURN AUTHORIZATION NUMBER CALL (888) 741-9840</b>	<b><u>ANY REPAIR RETURNED WITHOUT A RETURN AUTH. # WILL BE REFUSED!!</u></b>

## PARTS LIST FOR THE AC8004

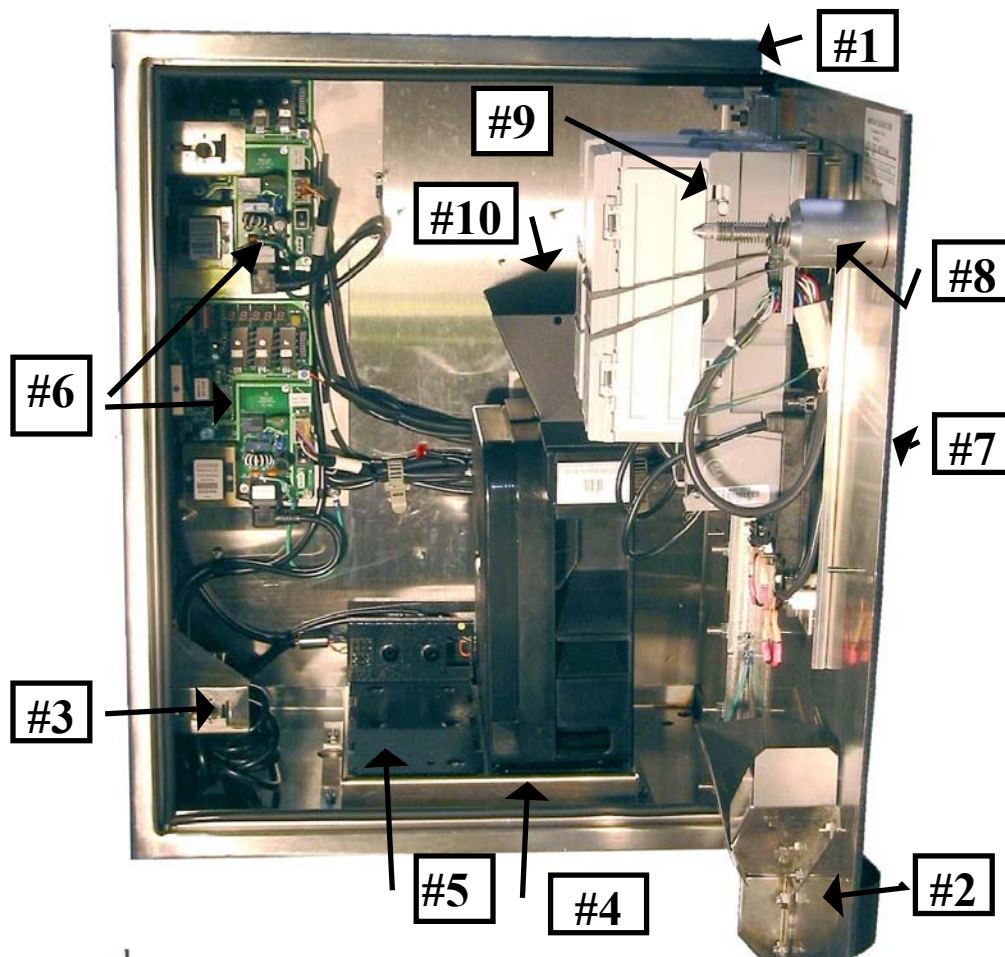

### AC8004 PARTS LIST (SHOWN ABOVE)

- |     |                  |   |
|-----|------------------|---|
| 1.  | <b>AC8012</b>    | -CABINET COMPLETE W/ COIN CUP (#2) & LOCK BRACKET (#3). |
| 2.  | <b>8012-01</b>   | -COIN CUP   |
| 3.  | <b>AC8010-05</b> | -LOCK BRACKET ASSY. COMPLETE.                           |
| 4.  | <b>AC1041</b>    | -COIN CONTROLS MKIV COIN HOPPER.                        |
| 5.  | <b>AC1040.3</b>  | -COIN CONTROLS HOPPER PLATE W/ FEMALE PLUG & HARNESS.   |
| 6.  | <b>AC1061</b>    | -MAIN LOGIC BOARD.                                      |
| 7.  | <b>AC8087</b>    | -FULL FACE LEXAN FRONT.                                 |
| 8.  | <b>AC8080</b>    | -HIGH SECURITY LOCK ASSY. COMPLETE                      |
| 9.  | <b>AC9003</b>    | -MARS BILL VALIDATOR.                                   |
| 10. | <b>8012-02</b>   | -HOPPER EXTENSION                                       |

### AC8004 OPTIONAL PARTS LIST (ITEMS NOT SHOWN.)

- |                 |                                       |
|-----------------|---------------------------------------|
| <b>AC9001.1</b> | <b>-COINCO BILL VALIDATOR</b>         |
| <b>AC2061</b>   | <b>-LOGIC BOARD FOR COIN MECH</b>     |
| <b>AC1092</b>   | <b>-MEDICO LOCK AND KEY</b>           |
| <b>1095-01</b>  | <b>- EXTRA KEYS</b>                   |
| <b>AC2066.3</b> | <b>-NICKEL/DIME ACCEPTOR</b>          |
| <b>AC8070</b>   | <b>-26" CONSOLE BASE</b>              |
| <b>AC8070.1</b> | <b>-30" FINISHED BASE WITH FOOTER</b> |
| <b>8904</b>     | <b>-MANUAL AC8004</b>                 |
| <b>8080-04</b>  | <b>-HEX BOLT DOOR CRANK</b>           |



- #1 - 1041-24-01  
Motor
- #2 - 1041-24-02  
Motor Side Cover
- #3 - 1041-24-03  
Center Plate
- #4 - 1041-24-04  
End Plate
- #5A- 1041-24-05  
Coin Counting Optic Board.
- #5B- 1041-24-06  
Optic ribbon cable
- #6 - 1041-24-07  
Red track plates  
(16 per belt).
- #7 - 1041-24-08  
Logic board wire harness
- #8 - 1040-24-113  
Male 12 pin connector
- #9 - 1040-24-112  
Female 12 pin connector.
- #10 - 1041-24-12  
Idler gear
- #11 - 1041-24-13  
Gear Box
- #12 - 1041-24-14  
Gear Shaft.
- #13 - 1041-24-15  
Gear #1 Plastic
- #14 - 1041-24-16  
Gear #2 & #3 Metal
- #15 - 1041-24-17  
Output gear
- #16 - 1041-24-18  
Gear #4 Metal, thick
- #17 - 1040-24-22  
Blanking Plate

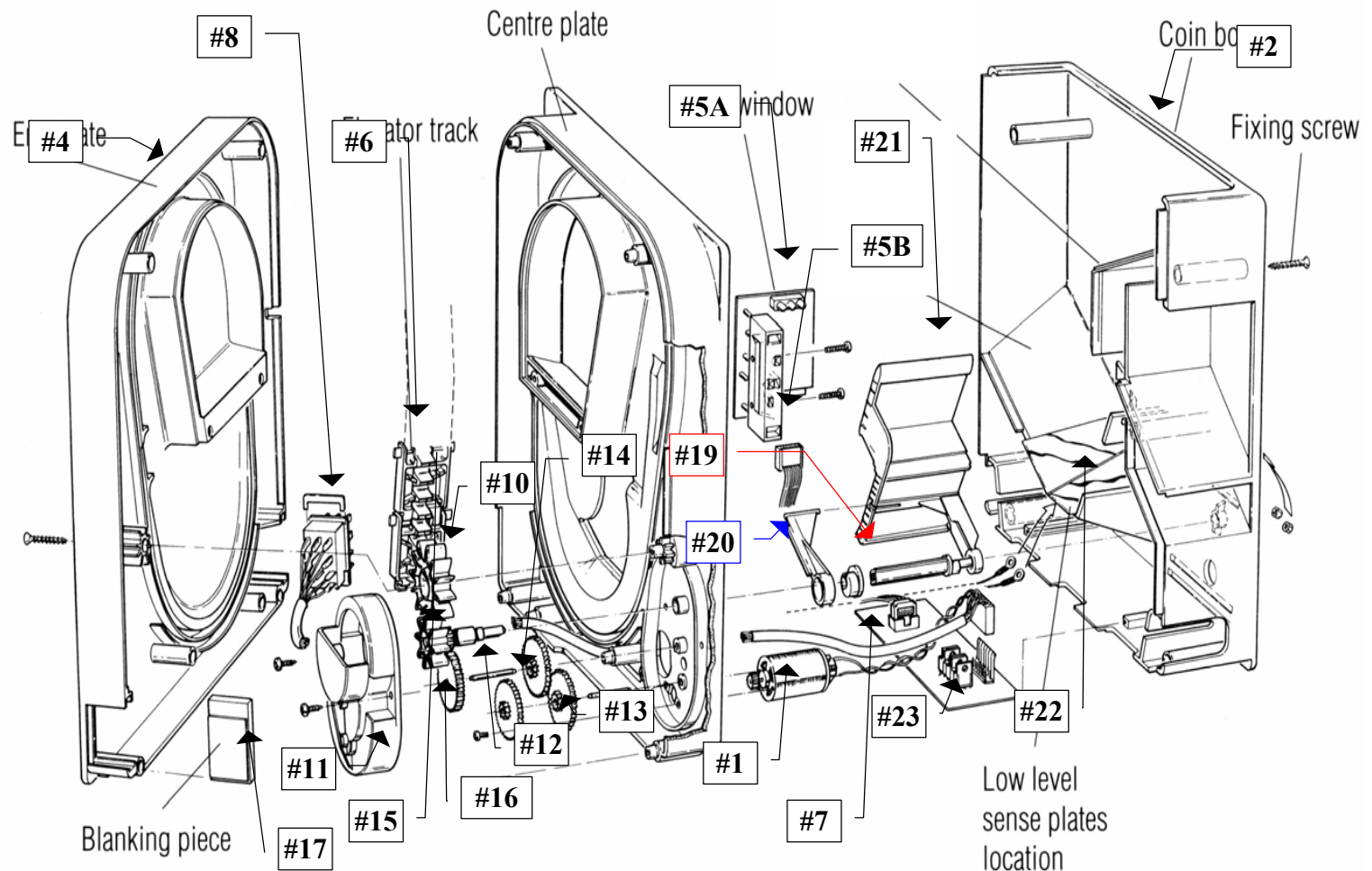

- #18 - 1040-24-25  
Fixing screw
- #19 - 1041-24-19  
Cam Shaft
- 1041-24-20  
Cam shaft bearing.
- #20 - 1041-24-21  
Cam Agitator

- #21 - 1041-24-22  
Agitator.
- #22 - 1040-24-291  
Low level contact plate.

- #23 - 1041-27-373  
Mark IV PC logic board

## COINCO PARTS LIST

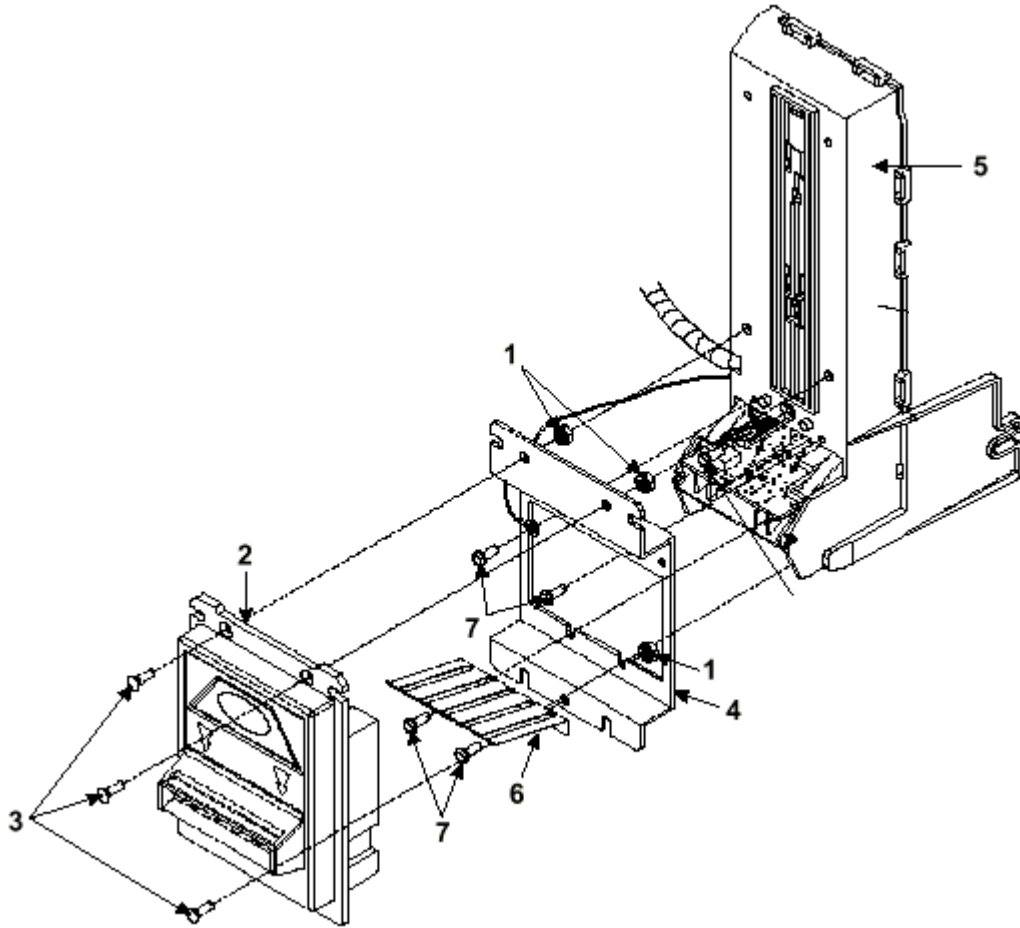

<u>PICTURE #</u>	<u>PART #</u>	<u>DESCRIPTION</u>
#1	MP90-1-1	Machine Screw
#2	MP91-1-2	"Snack Mask" Black Plastic
#3	MP90-1-3	Machine Screw
#4	MP90-1-4	Main Frame, Plastic
#5	MP91-1-5	Mask Gold Mounting Bracket
#6	MP90-1-6	Bill grounding spring
#7	MP91-1-7	Machine Nut

## COINCO PARTS BREAKDOWN

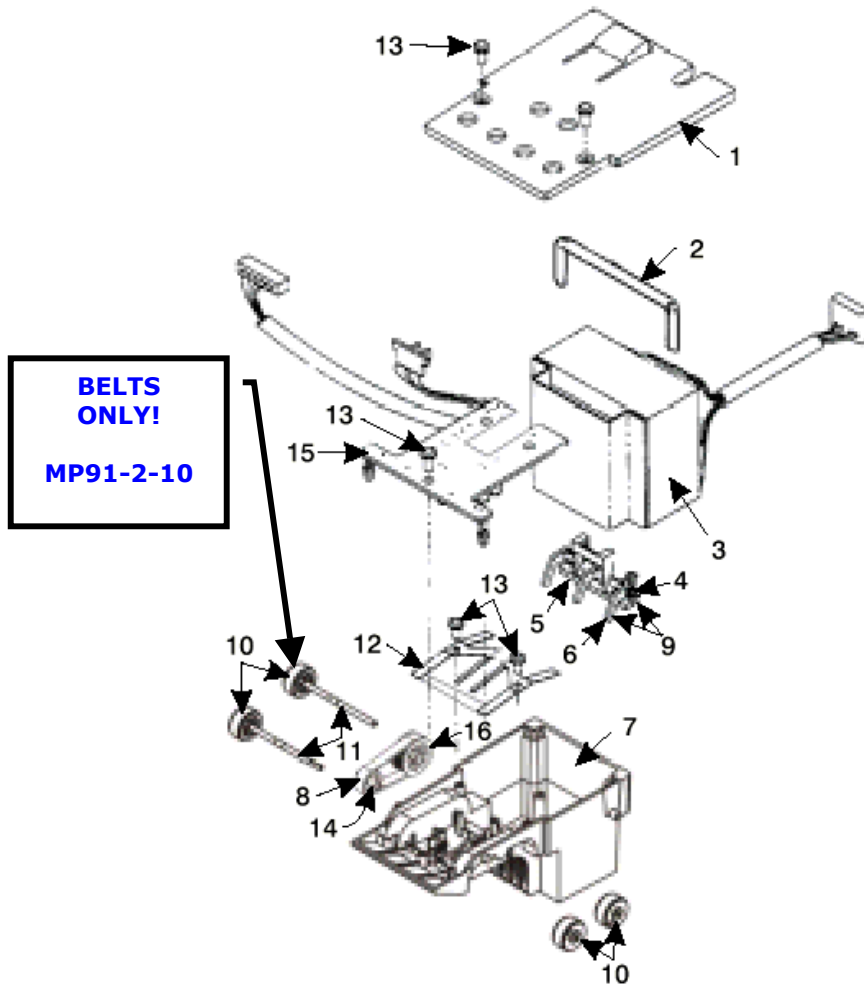

<u>PICTURE #</u>	<u>PART #</u>	<u>DESCRIPTION</u>
#1	MP90-2-1	Bottom Lower Housing Cover
#2	MP90-2-2	Transformer holding hose
#3	MP90-2-3	120VAC Transformer
#4	MP90-2-4	Lower Spring, Anti-Cheat Lever
#5	MP91-2-5	Lower Mounting, Anti-Cheat Lever
#6	MP90-2-6	Lower Anti-Cheat Lever
#7	MP90-2-7	Lower Housing Assembly, Complete
#8	MP90-2-8	Belt, Center
#9	MP90-2-9	Lower Anti-Cheat Assembly, Complete
#10	MP90-2-10	Plastic Wheels & Rubber Belts
<b>#10</b>	<b>MP91-2-10</b>	<b>Rubber Belts ONLY (Each)</b>
#11	MP90-1-11	Shaft, Drive
#12	MP90-2-12	Spring, MAG
#13	MP90-2-13	Screw, #4, Plastic
#14	MP90-2-14	Roller, Idler
#15	MP91-2-15	Sensor Board, Lower
#16	MP91-2-16	Pulley & Hub Assembly, Complete

## COINCO PARTS BREAKDOWN

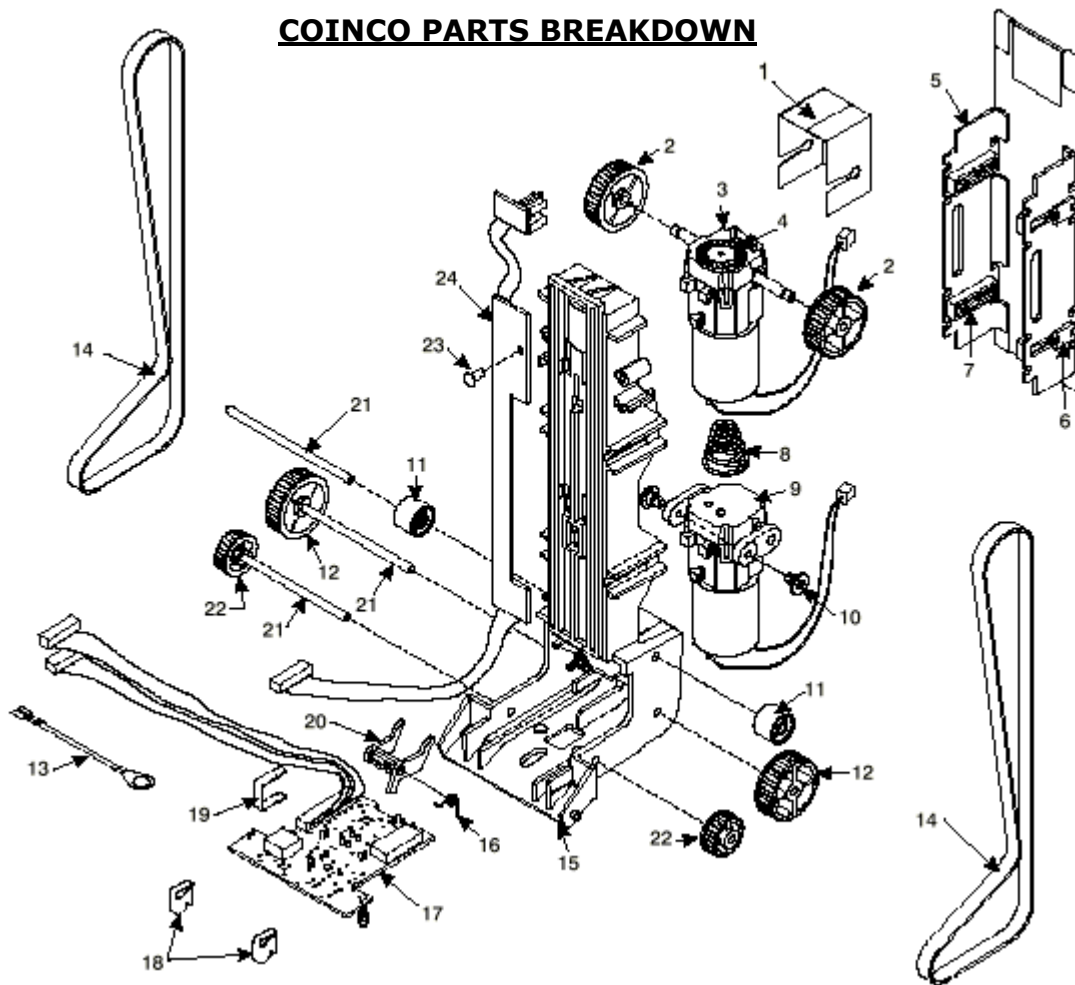

<u>PICTURE #</u>	<u>PART #</u>	<u>DESCRIPTION</u>
#1	MP90-3-1	Dust Cover
#2	MP90-3-2	Upper Transport & Hub Assembly, Complete
#3	MP91-3-3	Motor, Transport & Gear Assembly Complete
#4	MP90-3-4	Wheel, Encoder
#5	MP90-3-5	Stacker, Push-Plate Assembly
#8	MP90-3-8	Spring, Belt Tension
#9	MP90-3-9	Motor, Stacker Assembly Complete
#10	MP90-3-10	Pulley, Idler
#11	MP90-3-11	Lower Transport Pulley & Hub Assembly
#13	MP90-3-13	Belt, Upper Housing
#14	MP90-3-14	Frame, Upper Housing
#15	MP91-3-15	Sensor Board, Upper Housing
#16	MP90-3-16	Upper Board Clip
#17	MP90-3-17	Wire Clip
#18	MP90-3-18	Shaft, Pulley
#19	MP90-3-19	Shaft, Wheel
#21	MP90-3-21	Board, Stacker

## COINCO PARTS BREAKDOWN

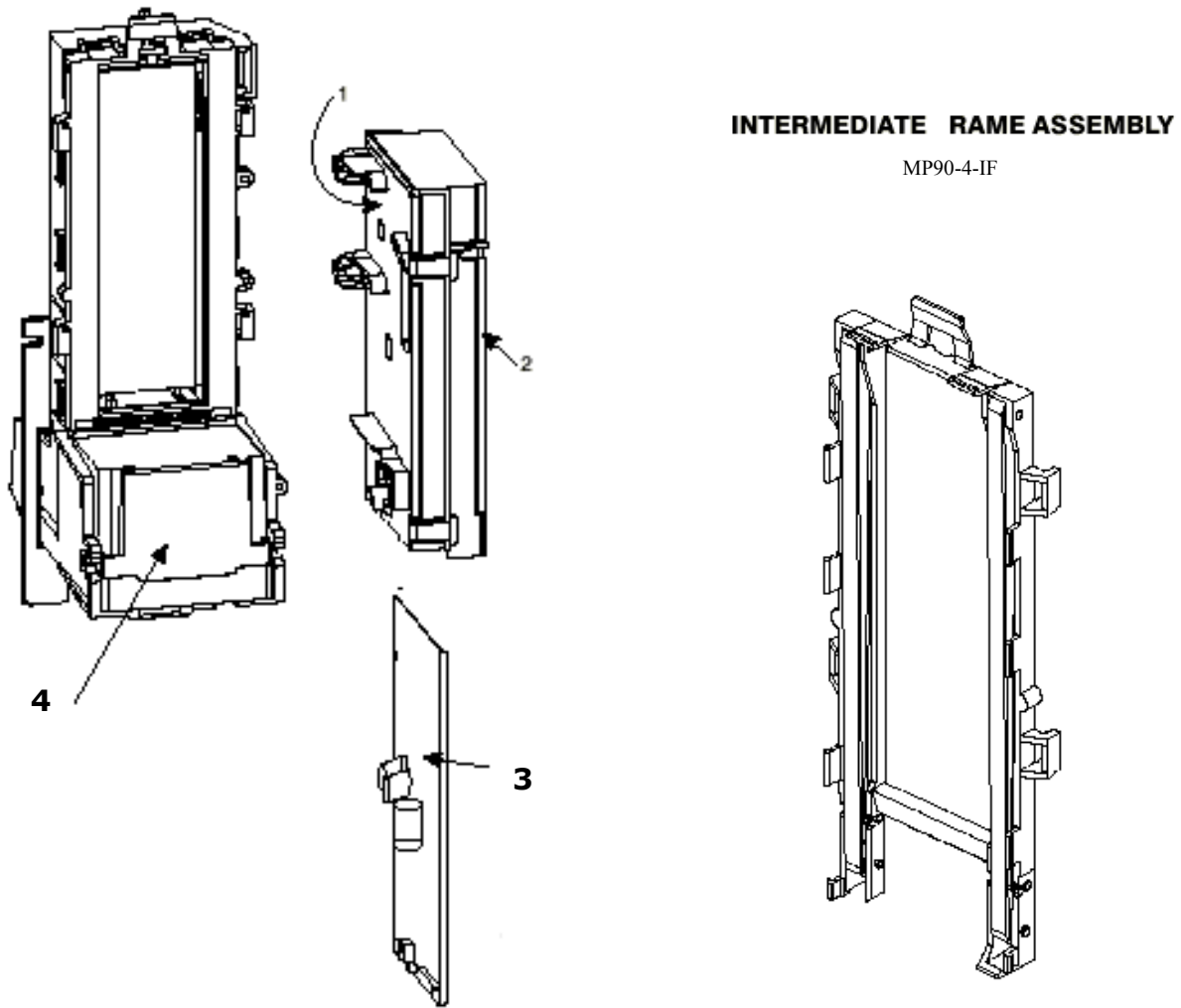

<u>PICTURE #</u>	<u>PART #</u>	<u>DESCRIPTION</u>
#1	MP90-4-1	Lid, Logic board Box
#2	MP91-4-2	Body, Logic board Box
#3	MP90-4-3	Main Logic Board
#4	MP90-4-4	Sticker, Serial Number / Warranty
#5	MP90-4-IF	Intermediate Frame with Bearings

**MARS AE2600 SERIES 24VDC PARTS BREAKDOWN**

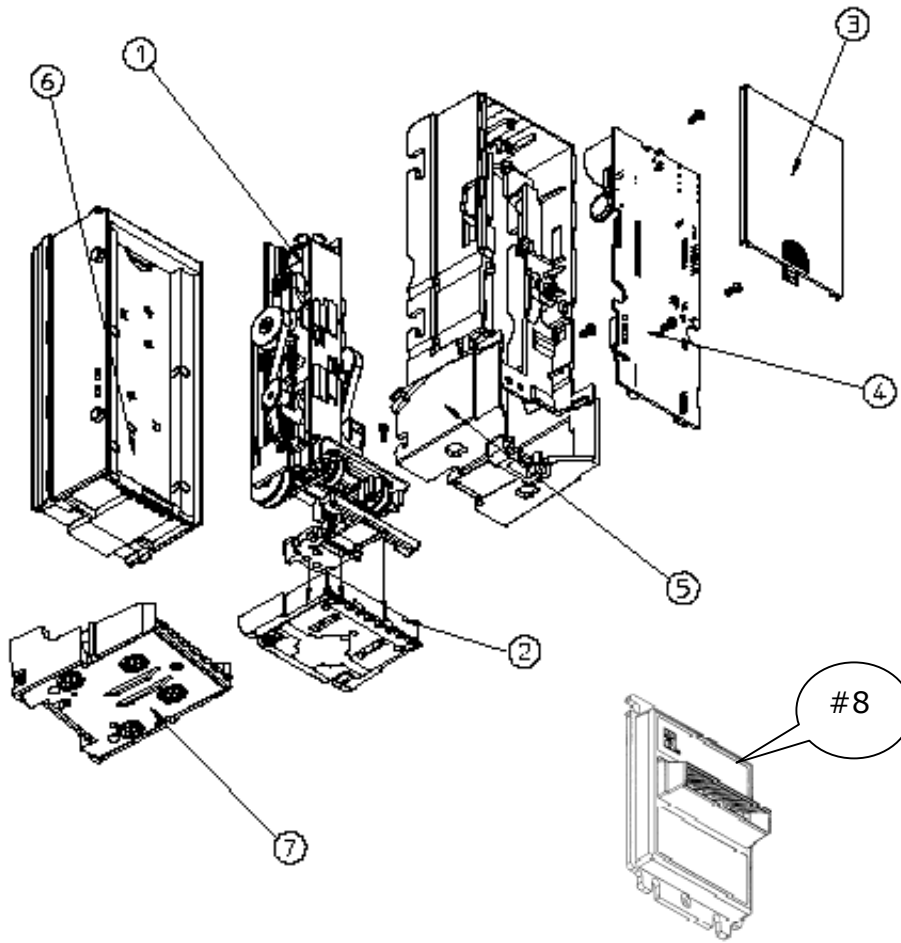

<b><u>PICTURE #</u></b>	<b><u>PART #</u></b>	<b><u>DESCRIPTION</u></b>
#1	AE93-1-1	Stacker/Drive Assembly Kit
#2	AE93-1-2	Sensor Housing Assy, Complete
#3	AE93-1-3	Control Board Cover, Plastic
#4	AE93-1-4	120VAC Logic Board
#5	AE93-1-5	Main Chassis, Plastic
#6	AC1045	500 Stacker
#7	AE93-1-7	LED Housing Assy, Complete
#8	AE93-1-8	Black Front Bezzle, Plastic
#9	AE93-1-9	Metal Bezzle Support Plate ( <b>NOT SHOWN</b> )

**CONTINUED**

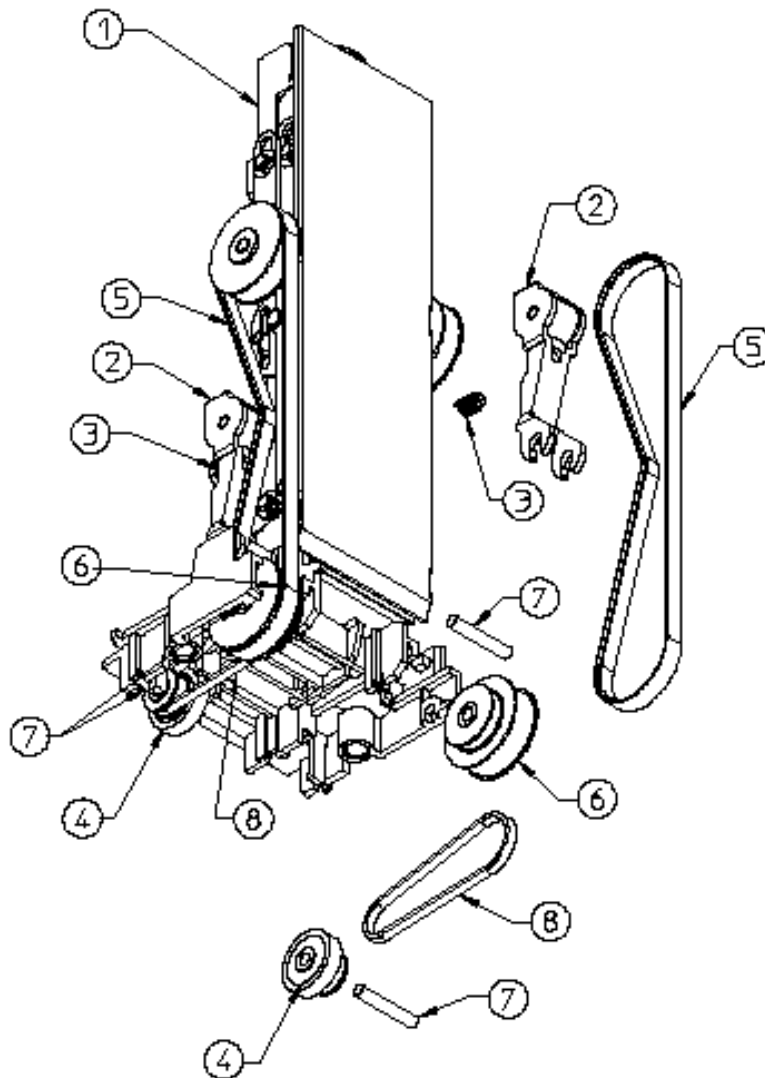

<b><u>PICTURE #</u></b>	<b><u>PART #</u></b>	<b><u>DESCRIPTION</u></b>
#1	AE93-2-1	Gearbox Assy
#2	AE93-2-2	Tension Assy
#3	AE93-2-3	Tension spring
#4	AE93-2-4	Tire/Wheel Assy
#5	AE93-2-5	Belt, Timing, (1 of 2)-143 Teeth
#6	AE93-2-6	Pulley, Compound
#7	AE93-2-7	Shaft, Pulley
#8	AE93-2-8	Belt, Timing, (1 of 2)-56 Teeth



**CONTINUED**

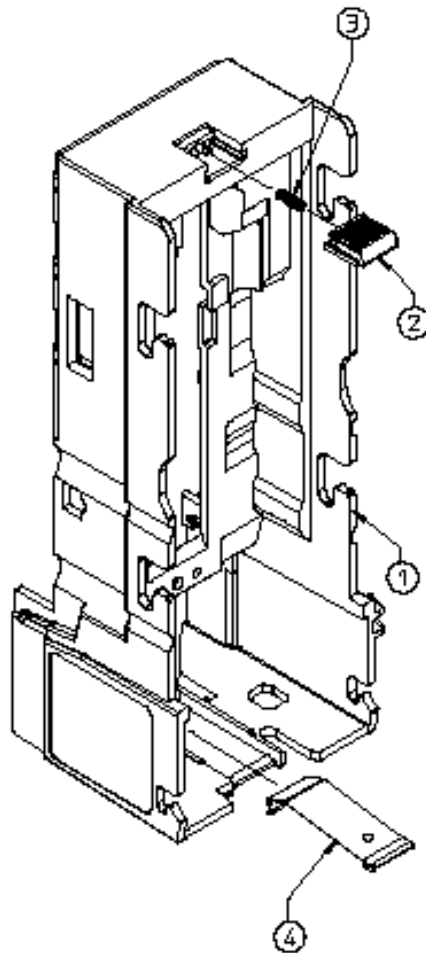

<b><u>PICTURE #</u></b>	<b><u>PART #</u></b>	<b><u>DESCRIPTION</u></b>
#1	AE93-1-5	Main Chassis, Plastic
#2	AE93-3-2	Stacker Latch, Blue
#3	AE93-3-3	Spring, Stacker Latch
#4	AE93-3-3	Lower Housing Lift Spring

# CoinCo Authorized Service Centers

## **Arizona**

3226 S. Fair Lane  
Tempe, AZ 85282  
Phone: 602-431-0632  
Chris Mattingly

## **California**

11618 E. Washington Blvd.  
Suite # J  
Whittier, CA 90606  
Phone: 562-692-3059

## **FLORIDA**

### **Tampa**

6704 Benjamin Road  
Suite 200  
Tampa, FL 33634  
Phone: 813-249-7338  
Bob Wilcox

### **Ft. Lauderdale**

American Changer  
1400 NW 65<sup>th</sup> Place  
Ft. Lauderdale, FL 33309  
888-741-9840  
RMA# Needed

## **Georgia**

4215 Wendall Dr SW  
Suite # E  
Atlanta, GA 30336  
Phone: 404-691-2777  
Chuck Crockett

## **Illinois**

862 Eagle Dr.  
Bensenville, IL 60106  
Phone: 630-860-2650  
Mike Durec

## **Louisiana**

524 Elmwood Pkwy  
Suite 190  
Harahan, LA 70123  
Phone: 504-734-0280  
Frank Case

## **Maryland**

6655 Amberton Drive  
Bay "L"  
Baltimore, MD 21227  
Phone: 410-379-2680  
Bill LeJune

## **Massachusetts**

60 Prospect Street  
Waltham, MA 02453  
Phone: 781-894-4525  
Kevin Cole

## **Missouri**

1236 Dielman Industrial CT  
St Louis, MO 63132  
Phone: 314-725-0100  
Charlie Pavia

## **Ohio**

225 Corporate Court  
Suite I  
Fairfield, OH 45014  
Phone: 513-874-4460  
Joe Steddom

## **TEXAS**

### **Dallas**

3031 Quebec Street  
Suite 115  
Dallas, TX 75247  
Phone: 214-638-3970

### **Houston**

2500 Central Parkway  
Suite "K"  
Houston, TX 77092  
Phone: 713-683-6558  
Steve TenBarge

### **Washington**

1020 Industrial Drive  
Bldg. 32  
Seattle, WA 98188  
Phone: 206-575-1999  
Carl Goodson



# MARS Authorized Service Centers

## ALABAMA

Birmingham Vending Co.  
Mr. Gerald Spiegelman  
540 N. 2nd Avenue  
Birmingham, AL 35204  
Phone: 205-324-7526  
Fax: 205-322-6639  
Email:  
[wendell@bhmvending.com](mailto:wendell@bhmvending.com)  
Web Site:  
[www.bhmvending.com](http://www.bhmvending.com)

## ARIZONA

Vendtronics  
Mr. Ken Van Leer  
4020 Grand Avenue, Suite #21  
Phoenix, AZ 85019-3173  
Phone: 602-973-3300  
Fax: 602-973-0033  
Email: [vendtronic@aol.com](mailto:vendtronic@aol.com)

## CALIFORNIA

Betson West  
Mr. John McCann  
5660 Knott Avenue  
Buena Park, CA 90621  
Phone: 714-228-7500  
Fax: 714-228-7510  
Web Site: [www.betson.com](http://www.betson.com)

Betson West  
Mr. Ben Fresenhazion  
213 E. Harris Avenue  
San Francisco, CA 94080  
Phone: 650-952-4220  
Fax: 650-827-3420  
Web Site: [www.betson.com](http://www.betson.com)

C.A. Robinson, Inc.  
Mr. James Tomei  
180 Utah Avenue  
S. San Francisco, CA 94080  
Phone: 650-871-4280  
Fax: 650-588-8538

G&K Service  
Mr. Vince D'Agostino  
4364 Twain Avenue, Unit #4  
San Diego, CA 92120  
Phone: 619-281-9227  
Fax: 619-281-8706

Superior Sales & Service  
Mr. Esko Wallace  
299 Old County Road, Suite 26  
San Carlos, CA 94070  
Phone: 800-995-8363 or  
650-591-2193  
Fax: 650-591-1712  
Email: [supsale@pacbell.net](mailto:supsale@pacbell.net)

Trilogy Magnetics, Inc  
Mr. Ed Colmenares  
16250 Gundry Avenue  
Paramount, CA 90723  
Phone: 562-663-1800  
Fax: 562-633-6408

## COLORADO

Mountain Coin Distributors  
Mr. Jack Brown  
345 W. 62nd Avenue  
Denver, CO 80216  
Phone: 800-654-2646 or  
303-427-2133  
Fax: 303-429-2104  
Email: [coinshop@msn.com](mailto:coinshop@msn.com)

## FLORIDA

V.E. South, L.C.  
Mr. Joe Gilbert  
4800 N.W. 15th Avenue  
Ft. Lauderdale, FL 33309  
Phone: 888-837-6884 or  
954-491-7300  
Fax: 954-491-7301  
Email: [vesouth@gate.net](mailto:vesouth@gate.net)  
Web Site: [www.vesouth.com](http://www.vesouth.com)

Vendor's Repair Service, Inc.  
Mr. George Uilano  
6025 Cinderlane Parkway  
Orlando, FL 32810  
Phone: 407-291-1712  
Fax: 407-578-0651  
[george@vendorsrepair.com](mailto:george@vendorsrepair.com)  
Web Site: [www.vendorsrepair.com](http://www.vendorsrepair.com)

## GEORGIA

North Atlantic Marketing\*  
Mr. Kirk Chambless  
Norcross Center  
2100 Norcross Parkway,  
Suite 130  
Norcross, GA 30071  
Phone: 800-442-2388 or  
770-449-5001  
Fax: 770-729-1144

Southeastern Vending  
Mr. Johnny Williams  
1886 Forge Street  
Tucker, GA 30084  
Phone: 800-825-8554 or  
770-621-9055  
Fax: 770-621-9055  
Email: [repairshop32@aol.com](mailto:repairshop32@aol.com)

## ILLINOIS

American Vending Sales, Inc.  
Mr. Frank Manduno  
750 Morse Avenue  
Elk Grove Village, IL 60007  
Phone: 847-439-9400  
Fax: 847-439-9405  
Email:  
[isharps@americanvending.com](mailto:isharps@americanvending.com) or  
[rnair@americanvending.com](mailto:rnair@americanvending.com)  
Web Site:  
[www.americanvending.com](http://www.americanvending.com)

## INDIANA

Shaffer Distributing  
Mr. Ron Dixon  
9461 E. Washington Street  
Indianapolis, IN 46229  
Phone: 800-876-0789 or  
317-899-2530  
Fax: 317-899-6080  
Email: [shafdist@netdirect.net](mailto:shafdist@netdirect.net)  
Web Site:  
[www.schafferdistributing.com](http://www.schafferdistributing.com)

**LOUISIANA**

Sur Serv Corp.  
Mr. Julian Ortiz  
2920 Kingman Street  
Suite 118  
Meltaire, LA 70006  
Phone: 504-887-1661  
Fax: 504-887-9081  
Email: [surserv@surserv.com](mailto:surserv@surserv.com)

**MARYLAND**

Betson  
Ms. Angie Swann  
3431A Benson Avenue  
Baltimore, MD 21227  
Phone: 800-296-4100  
Fax: 410-646-2053  
Email: [aswann@betson.com](mailto:aswann@betson.com)

**MASSACHUSETTS**

Gekay Electronics Corp.  
Mr. Rob Collette  
16 Deer Park Drive  
E. Longmeadow, MA 01028  
Phone: 800-832-0028 or  
413-525-2700  
Fax: 413-525-6886

**MICHIGAN**

Wolverine American, Inc.  
Mr. John Paskeretti  
26400 Capitol  
Redford, MI 48239  
Phone: 313-937-4600  
Fax: 313-937-1802

Wolverine American, Inc  
Mr. John Paskeretti  
3400 Jefferson Avenue, SE  
Grand Rapids, MI 49548  
Phone: 616-452-2125  
Fax: 616-452-3319

**MINNESOTA**

Changer Services, Inc.  
Mr. Mark Stolley  
7721 Pillsbury Avenue South  
Richfield, MN 55423  
Phone: 888-328-5067 or  
612-798-3610  
Fax: 612-798-3614  
Email:  
[mstolley@changerservices.com](mailto:mstolley@changerservices.com)

Viking Vending  
Mr. Guy Jones  
9549 Penn Avenue, South  
Minneapolis, MN 55431  
Phone: 800-879-0321  
Fax: 612-887-5656  
Email:  
[auneb@liebermanmusic.com](mailto:auneb@liebermanmusic.com)  
Web Site:  
[www.liebermanmusic.com](http://www.liebermanmusic.com)

**MISSOURI**

Greater America  
Mr. Duane Zarger  
3230 Roanoke Road  
Kansas City, MO 64111  
Phone: 816-531-4300  
Fax: 816-531-4337

Midwest Associates, Inc.  
Mr. Glen Politte  
9334 Highway BB  
Hillsboro, MO 63050  
Phone: 800-237-0521  
Fax: 636-789-5848  
Email: [midwest@inlink.com](mailto:midwest@inlink.com)  
Web Site: [www.mwassoc.com](http://www.mwassoc.com)

Shaffer Distributing Co  
Mr. Chuck Ropke  
2111 January Avenue  
St. Louis, MO 63110  
Phone: 314-645-3393  
Phone: 314-645-3689

**MONTANA**

Action Gaming Technology\*  
Mr. Harold Heyer  
P.M.B. 117  
425 N. 5<sup>th</sup> Street  
Missoula, MT 59802  
Phone: 406-728-0034  
Fax: 406-549-0688  
Email: [actiongt@yahoo.com](mailto:actiongt@yahoo.com)

**NEVADA**

Mars Electronics International\*  
2700 East Patrick Lane, Suite 1  
Las Vegas, NV 89120  
Phone: 702-597-4836  
Fax: 702-597-4837  
Email: [bill.nichols@effem.com](mailto:bill.nichols@effem.com)

**NEW JERSEY**

Betson Enterprises  
Mr. Rob Zigmont  
303 Paterson Plank Road  
Carlstadt, NJ 07072  
Phone: 800-524-2343 or  
201-438-1300  
Fax: 201-438-4837  
Email: [zigrob103@aol.com](mailto:zigrob103@aol.com)  
Web Site: [www.betson.com](http://www.betson.com)

Ellenby Technologies, Inc.\*  
Mr. Bob Dobbins  
1460 Grandview Avenue, Unit 2  
MidAtlantic Corporate Center  
West Deptford, NJ 08066  
Phone: 856-848-2020  
Fax: 856-848-7080  
Email: [ellenby@aol.com](mailto:ellenby@aol.com)

**NORTH CAROLINA**

Brady Distributing Co., Inc.  
Mr. Roger Harrison  
2708 Yorkmont Road  
Charlotte, NC 28208  
Phone: 704-357-6284  
Fax: 704-357-1243  
Email: [rharrison@bradydist.com](mailto:rharrison@bradydist.com)  
Web Site: [www.bradydist.com](http://www.bradydist.com)

Southeastern Vending  
Mr. John Hollar  
2748-B Interstate Street  
Charlotte, NC 28208  
Phone: 800-825-8555 or  
704-394-4911  
Fax: 704-394-3789  
Email: [svsinc@juno.com](mailto:svsinc@juno.com)

**OHIO**

Shaffer Distributing Co.  
1100 W. Third Avenue  
Columbus, OH 43212  
Phone: 800-282-0194 or  
614-421-6800 Extension 114  
Fax: 614-294-2669  
Email: [service@shafferdistributing.com](mailto:service@shafferdistributing.com)  
Web Site:  
[www.shafferdistributing.com](http://www.shafferdistributing.com)

Vendors Exchange  
Mr. Brent Garson  
4020 Payne Avenue  
Cleveland, OH 44103  
Phone: 800-321-2311 or  
216-432-1800  
Fax: 216-432-2786  
Email: [Info@veii.com](mailto:Info@veii.com)  
Web Site: [www.veii.com](http://www.veii.com)

**OKLAHOMA**

Aeco Sales & Service  
 Ms. Kacy Parker  
 619 North Broadway  
 Tecumseh, OK 74873  
 Phone: 800-682-0358 or  
 405-598-2915  
 Fax: 405-598-5506  
 Email: [kacy\\_AECO@ionet.net](mailto:kacy_AECO@ionet.net)

**OREGON**

Mountain Coin Machine Distributors  
 Mr. Michael Damtew  
 6440 N.E. Halsey  
 Portland, OR 97213  
 Phone: 503-234-5491 or  
 800-233-5198  
 Fax: 503-233-3816  
 Email: [michael@dunis.com](mailto:michael@dunis.com)  
 Web Site: [www.mountaincoin.com](http://www.mountaincoin.com)

**PENNSYLVANIA  
MEI**

Mr. Al Serro  
 1301 Wilson Drive  
 West Chester, PA 19380  
 Phone: 610-430-2500  
 Fax: 610-430-2694  
 Email: [rob.dowling@effem.com](mailto:rob.dowling@effem.com)  
 Web Site: [www.meiglobal.com](http://www.meiglobal.com)

**SOUTH CAROLINA**

Drew Distributing, Inc.\*  
 Mr. Gabe Mull  
 9107 Ashville Highway  
 Boiling Springs, SC 29316  
 Phone: 864-578-4444  
 Fax: 864-599-6232  
 \*Limited Amusement Service Center

**TENNESSEE**

Brady Distributing Co., Inc.  
 Mr. Brian Drost  
 3306 Winbrook Drive  
 Memphis, TN 38116  
 Phone: 901-345-7811  
 Fax: 901-398-0578  
 Email: [Memphisshop@bradydist.com](mailto:Memphisshop@bradydist.com)  
 Web Site: [www.bradydist.com](http://www.bradydist.com)

**TEXAS**

Aeco Sales & Service  
 Mr. Eddy Parker  
 10290 Monroe Drive #206  
 Dallas, TX 75229  
 Phone: 214-352-4755  
 Fax: 214-352-8154

Serv-A-Mech Electronics, Inc  
 Mr. Jerry Camp  
 5916 West 34th Street #B  
 Houston, TX 77092  
 Phone: 800-323-7214 or  
 713-681-6277  
 Fax: 713-681-8570  
 Email: [sameinc@aol.com](mailto:sameinc@aol.com)

**UTAH**

Wachtor Electronics  
 Mr. Larry Wachtor  
 73 West Truman Avenue  
 Salt Lake City, UT 84115  
 Phone: 801-485-2289  
 Fax: 801-485-8745

**VIRGINIA**

Eastern Commercial Services  
 Mr. Bob Vose  
 813-A Professional Place, Suite 100  
 Chesapeake, VA 23320  
 Phone: 800-486-1020 or  
 757-436-1020  
 Fax: 757-547-4772  
 Email: [bobvose@easterncommercial.com](mailto:bobvose@easterncommercial.com)  
 Web Site: [www.easterncommercial.com](http://www.easterncommercial.com)

**WASHINGTON**

Wachtor Electronics  
 Mr. Larry Wachtor  
 232 S.W. 43rd Street  
 Renton, WA 98055  
 Phone: 425-251-0997  
 Fax: 425-251-8532

**WISCONSIN**

Pioneer Sales & Service  
 Mr. David Dropp  
 N55 W13875 Oak Lane  
 Menomonee Falls, WI 53051  
 Phone: 262-781-1420  
 Fax: 262-781-4307  
 Email: [Pioneers@execpc.com](mailto:Pioneers@execpc.com)  
 Web Site: [www.execpc.com1~pioneers](http://www.execpc.com1~pioneers)

Viking Vending pf Wisconsin  
 Mr. Brent McKennon  
 N59 W16600 Greenway Circle  
 Unit B  
 Menomonee Falls, WI 53051  
 Phone: 262-703-4168  
 Fax: 262-703-4171  
 Email: [brent.mckennon@vikingvending.com](mailto:brent.mckennon@vikingvending.com)