

NOZZLE SCHEDULE							
ITEM	SIZE	RATING	TYPE	MATL	PROJ IN	PROJ OUT	REMARKS
A	2"	N.P.T.	W.F.	C.S.	STD.	STD.	
B	3"	N.P.T.	W.F.	C.S.	STD.	STD.	EMERGENCY VENT OPENING
C	3/4"	N.P.T.	W.F.	C.S.	STD.	STD.	DRAIN

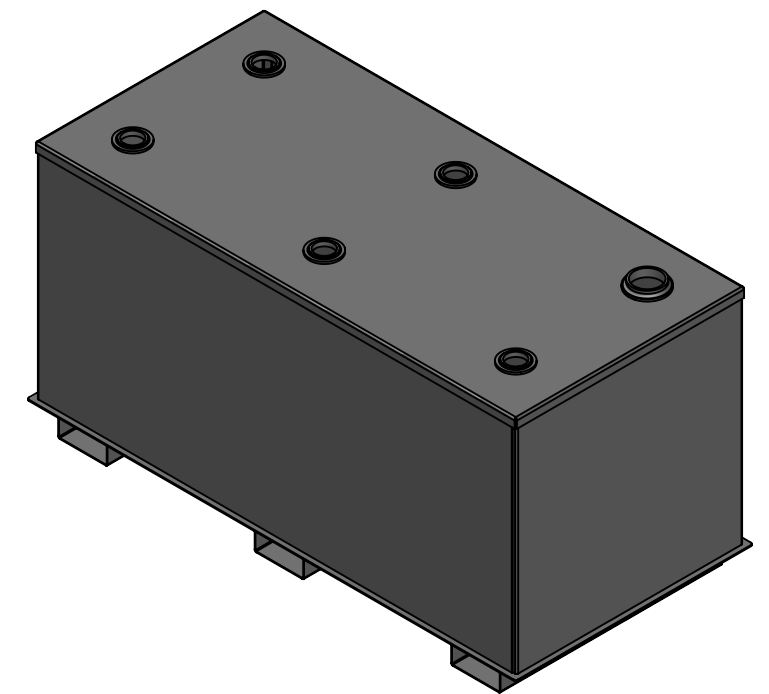
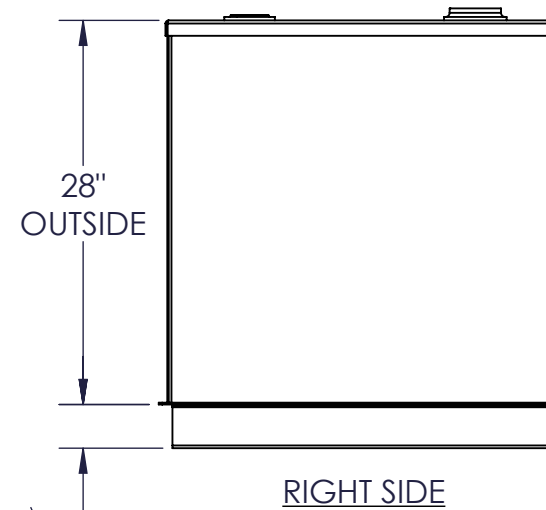
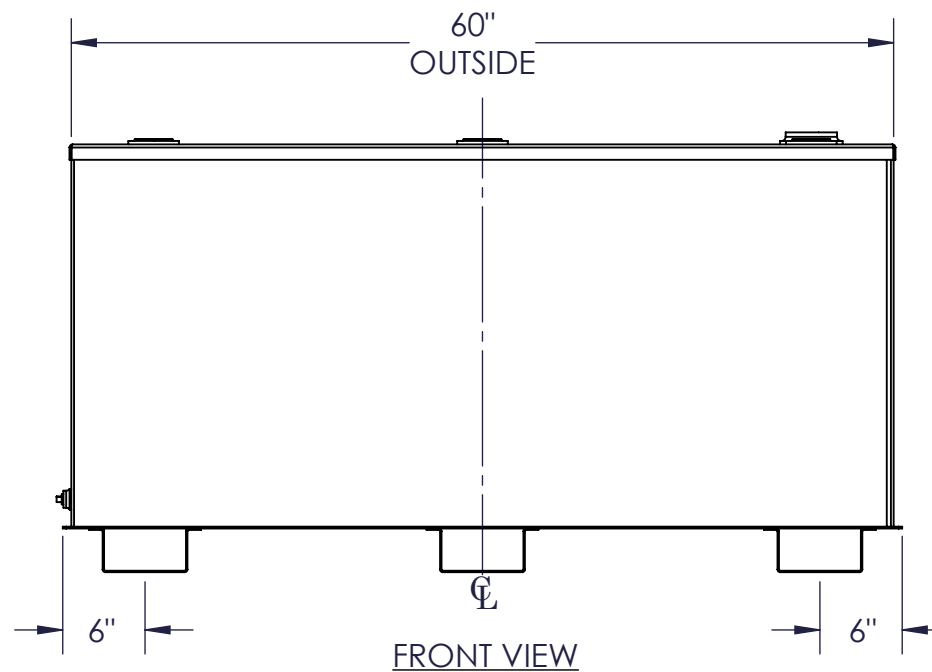
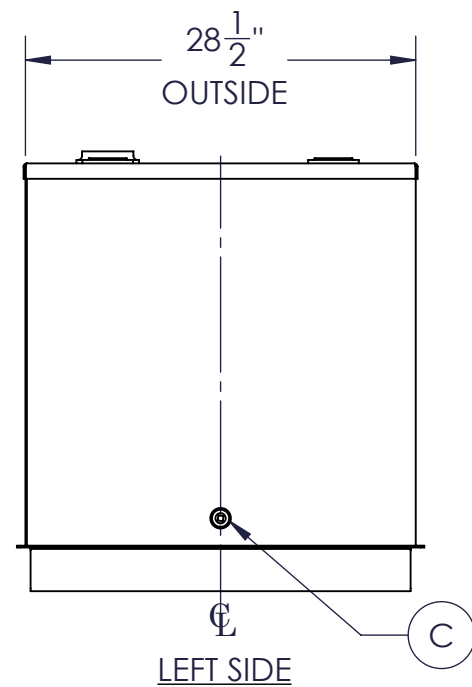

NOTES:

- A. QUANTITY:
- B. MATERIAL: H.R. CARBON STEEL
- C. TANK: 12 GA. W/10 GA. TOP
- D. DESIGN & OPERATING PRESSURE: ATOMOSPHERIC.
- E. DESIGN & OPERATING TEMPERATURE: AMBIENT.
- F. TANK TO BE BUILT & LABELED PER U.L. SPEC. #142.
- G. TANK TO BEAR MANUFACTURERS & U.L. LABELS ONLY.
- H. TANK TO BE AIR TESTED WITH WATER & SOAP SUDS SOLUTION.
- I. INTERIOR: REMOVE WELD SLAG (SHIP CLEAN & DRY).
- J. EXTERIOR: GRAY PRIMER INCLUDED; SEE SALES ORDER FOR TOP COAT.
- K. ALL FITINGS TO BE PROTECTED FOR SHIPMENT.
- L. CUSTOMER HAS THE RESPONSIBILITY TO VERIFY ALL DIMENSIONS.

APPROVAL FOR CONSTRUCTION
SCHEDULE A - MASTER TERMS &
CONDITION OF SALE*

APPROVED AS DRAWN.

APPROVED WITH NOTED CHANGES,
CONSTRUCTION WILL BE SCHEDULED
WHEN SIGNED DRAWING AND
CONFIRMED ORDER ARE RECEIVED.

SIGNATURE: _____

DATE: _____

*All pages of this Schedule A are incorporated by
reference and are a part of the additional terms of
the Master Terms & Conditions of Sale.
www.newberrytanks.com/masterterms.pdf

SALES ORDER: -			WEIGHT (LBS): 352
			All units inches unless stated otherwise
Phone: 870-735-4473 Fax: 870-735-3982			
DESCRIPTION: 200 GALLON RECTANGULAR UL 142 SINGLE WALL TANK			
CUSTOMER:			P.O.#
DATE: 9/8/2020	SCALE:	DWG.# FTSBS-0200	DRAWN BY: AJC
			SHEET 1 OF 1