Technical Data Sheet

3mm White Water Clear Through Hole LED

White

Version No.: 160104

Date: 04.01.2016

Part Number:

White: VL-L3-WC-6K (CW)

Warm White: VL-L3-WC-3K (WW)

Electrical Optical Characteristics (Ta=25°C)

Part No.	Colour	Colour Temp $\lambda_p(K)$	Forward voltage VF (V)	Reverse current IR (UA)	Luminous Intensity (mcd)	Viewing Angle $\theta_{1/2}$
		IF=20mA	IF=20mA	VR=5V	IF=20mA	IF=20mA
VL-L3-WC-6K (CW)	White	6500-7000	3.2 - 3.4	≤ 10	6000-8000	60
VL-L3-WC-3K (WW)	Warm White	2700-3000	3.2 - 3.4	≤ 10	5000-7000	60

FEATURES

Package profile	Unit: mm	Absolute Maximum Ratings At Ta=25°C
		Max Power dissipation
		PM=120mw
		Peak Forward Current
		IFM = 30mA
		DC Forward Current
		15mA - 18mA
		Positive pulse peak current
		IFP = 75mA
		Reverse Voltage
		5V
		Soldering Condition
		260°C < 5S)
		Operating Temperature
	-25°C to +85°C	
	Storage Temperature Range	
	-30°C to +85°C	

•SOLDERING

METHOD	SOLDERING CONDITIONS	REMARK
DIP SOLDERING	Bath temperature: 260±5°C Immersion time: with 5 sec	<ul style="list-style-type: none"> • Solder no closer than 3mm from the base of the package • Using soldering flux, "RESIN FLUX" is recommended.
SOLDERING IRON	Soldering iron: 30W or smaller Temperature at tip of iron: 260°C or lower Soldering time: within 5 sec.	<ul style="list-style-type: none"> • During soldering, take care not to press the tip of iron against the lead. (To prevent heat from being transferred directly to the lead, hold the lead with a pair of tweezers while soldering)

1) When soldering the lead of LED in a condition that the package is fixed with a panel (See Fig.1), be careful not to stress the leads with iron tip.

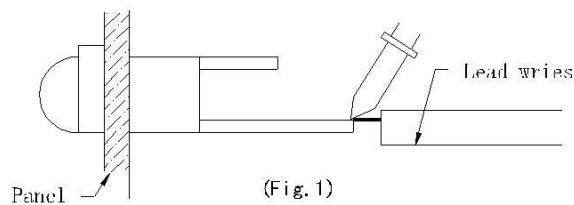

2) When soldering wire to the lead, work with a Fig (See Fig.2) to avoid stressing the package.

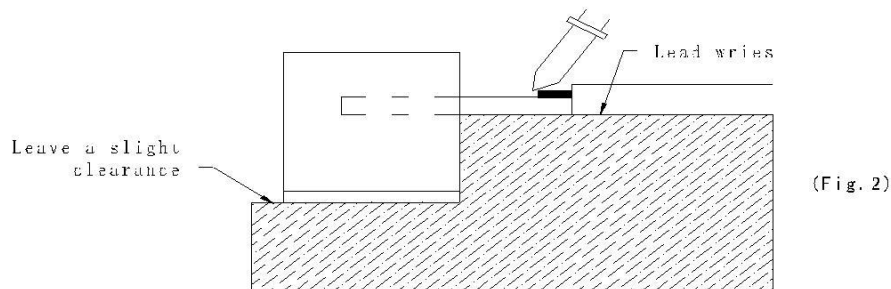

LED LAMP APPLICATION

- 3) Similarly, when a jig is used to solder the LED to PC board, take care as much as possible to avoid steering the leads (See Fig.3).

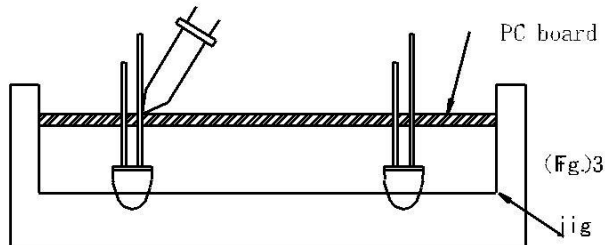

- 4) Repositioning after soldering should be avoided as much as possible. If inevitable, be sure to preserve the soldering conditions with irons stated above: select a best-suited method that assures the least stress to the LED.
- 5) Lead cutting after soldering should be performed only after the LED temperature has returned to normal temperature.

•LED MOUNTING METHOD

- 1) When mounting the LED by using a case, as shown Fig.4, ensure that the mounting holds on the PC board match the pitch of the leads correctly-tolerance of dimensions of the respective components including the LED should be taken into account especially when designing the case, PC board, etc. to prevent pitch misalignment between the leads and board holes, the diameter of the board holes should be slightly larger than the size of the lead. Alternatively, the shape of the holes should be made oval. (See Fig.4)

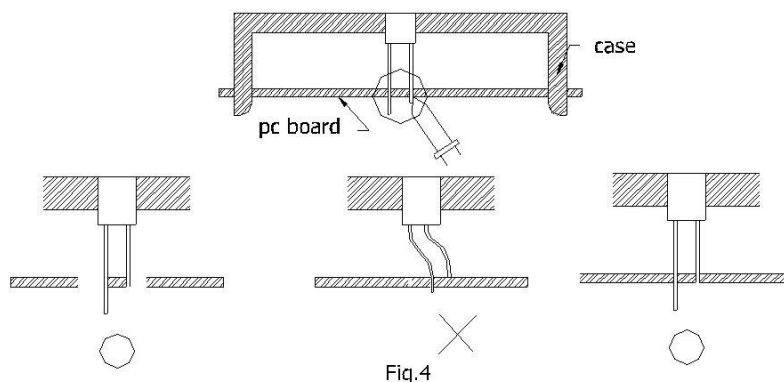

LED LAMP APPLICATION

2) Use LEDs with stand-off (Fig.5) or the tube or spacer made of resin (Fig.6) to position the LEDs.

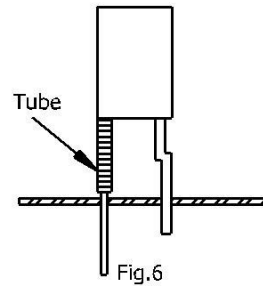
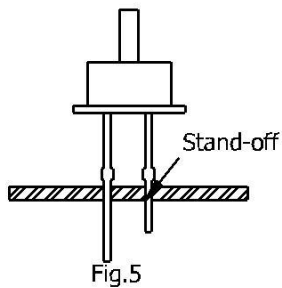

●FORMED LEAD

1) The lead should be bent at a point located at least 2mm away from the package. Bending should be performed with base fixed means of a jig or pliers (Fig.7)

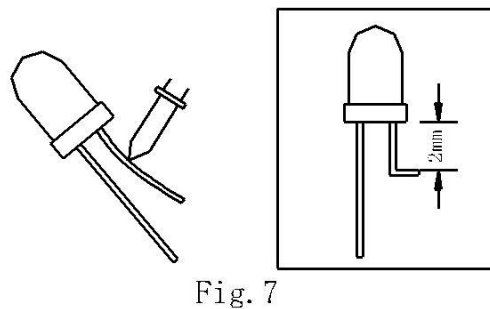

2) Forming lead should be carried out prior to soldering and never during or after soldering.

3) Form the lead to ensure alignment between the leads and the hole on board, so that stress against the LED is prevented. (Fig.8)

