



## **TOYO LED ELECTRONICS LIMITED**

Room 1610, Hong Kong Plaza, 188 Connaught Road West, Hong Kong.  
Tel : (852) 2540 7288 Fax : (852) 2517 1797  
http://www.toyo-led.com E-mail : sales@toyo-led.com



**P/N: TY-Y0603UR1(0.60)**

0603 Package 1.6\*0.8mm Surface Mount LEDs Series

# SPECIFICATION FOR CUSTOMER APPROVAL

## **P/N: TY-Y0603UR1(0.60)**

DATE : May 21, 2014

PREPARED BY : Yanguoliang

CONFIRMED BY :

**PLEASE CONFIRM & SIGN BACK THIS SHEET TO US**

**CUSTOMER:** \_\_\_\_\_

(COMPANY CHOP)

**APPROVAL BY:** \_\_\_\_\_

(SIGNATURE)



# TOYO LED ELECTRONICS LIMITED

Room 1610, Hong Kong Plaza, 188 Connaught Road West, Hong Kong.  
Tel : (852) 2540 7288 Fax : (852) 2517 1797  
http://www.toyo-led.com E-mail : sales@toyo-led.com



**P/N: TY-Y0603UR1(0.60)**

0603 Package 1.6\*0.8mm Surface Mount LEDs Series

## ✧ Features:

- 1.6\*0.8\*0.60 mm
- Mono-color type
- Soldering methods :All SMT assembly methods
- Comply ROHS standard

## ✧ Description

The Red source color devices are made with **AlGaInP** on sapphire Light Emitting Diode.

## ✧ Application

- LCD backlight
- Illuminations

## ✧ Package Dimensions

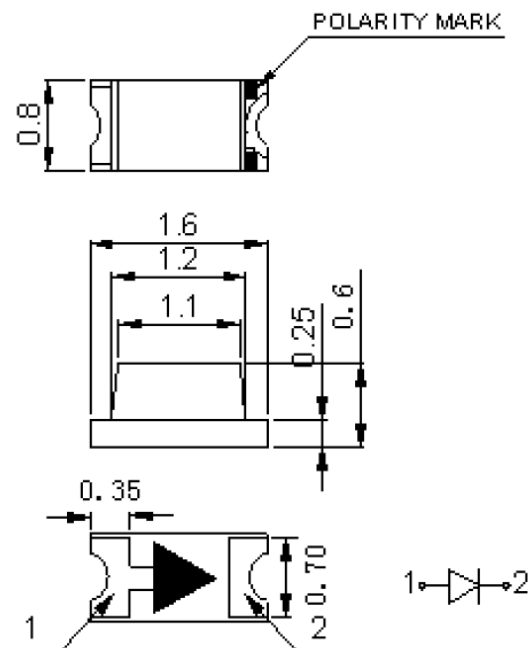

## NOTES :

1. All dimensions are in millimeter;
2. Tolerance is  $\pm 0.1$  mm unless other specified;
3. Specifications are subject to change without notice.



# TOYO LED ELECTRONICS LIMITED

Room 1610, Hong Kong Plaza, 188 Connaught Road West, Hong Kong.  
 Tel : (852) 2540 7288 Fax : (852) 2517 1797  
 http://www.toyo-led.com E-mail : sales@toyo-led.com



## P/N: TY-Y0603UR1(0.60)

0603 Package 1.6\*0.8mm Surface Mount LEDs Series

Part No.	Emitted Color	Lens Color	Chip Material
TY-Y0603UR1(0.60)	Red	Water Clear	AlGaInP

### ◇ Absolute Maximum Ratings(Ta=25 )

Item	Symbol	Maximum	Unit
Power Dissipation	PD	75	mW
Continuous Forward Current	I <sub>Fmax</sub>	30	mA
Peak Forward Current(1/10 Duty Cycle 0.1ms Pulse Width)	I <sub>FP</sub>	80	mA
Reverse Voltage	V <sub>R</sub>	5	V
Operating Temperature Range	T <sub>opr</sub>	-40 to+85	
Storage Temperature Range	T <sub>stg</sub>	-40 to+85	
Lead Solder Temperature	Tsol	260°C for 3 seconds	

### ◇ Electrical/Optical Characteristics(Ta=25 )

Item	Symbol	Condition	Min.	Typ.	Max	Unit
Forward Voltage	V <sub>F</sub>	I <sub>F</sub> =20mA	---	1.9	2.2	V
Luminous Intensity	I <sub>V</sub>	I <sub>F</sub> =20mA	70	150	--	mcd
Wavelength	λ	I <sub>F</sub> =20mA	--	617	625	nm
Viewing Angle	2θ <sub>1/2</sub>	I <sub>F</sub> =20mA	---	120	---	Deg
Reverse Current	I <sub>R</sub>	V <sub>R</sub> =5V	---	---	10	uA



# TOYO LED ELECTRONICS LIMITED

Room 1610, Hong Kong Plaza, 188 Connaught Road West, Hong Kong.  
 Tel : (852) 2540 7288 Fax : (852) 2517 1797  
 http://www.toyo-led.com E-mail : sales@toyo-led.com



**P/N: TY-Y0603UR1(0.60)**

0603 Package 1.6\*0.8mm Surface Mount LEDs Series

## ✧ Typical Electro-Optical Characteristics Curves

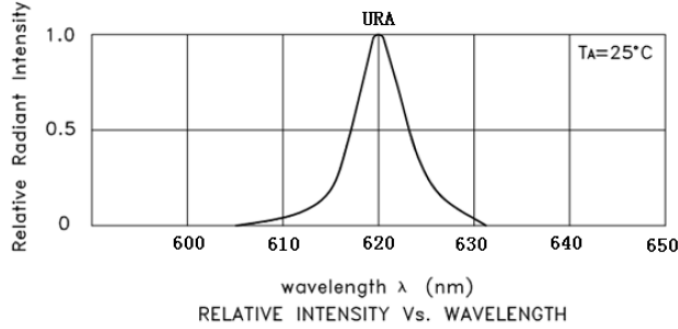

### E6C0603URAC1UDA

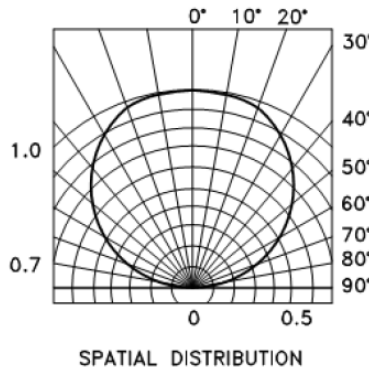
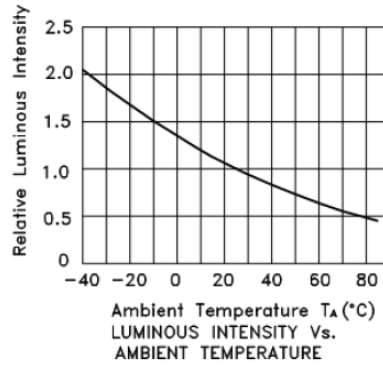
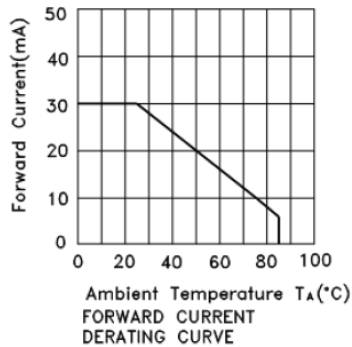
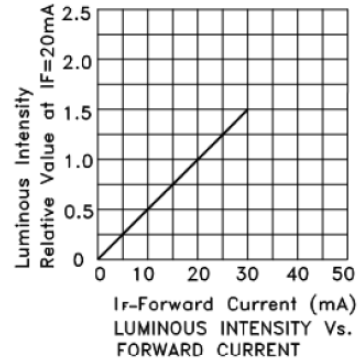
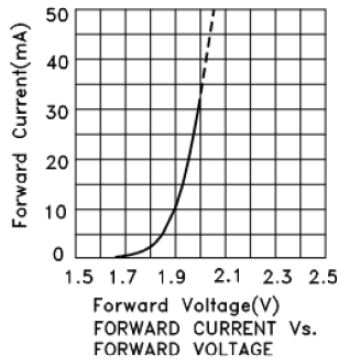



# TOYO LED ELECTRONICS LIMITED

Room 1610, Hong Kong Plaza, 188 Connaught Road West, Hong Kong.  
 Tel : (852) 2540 7288 Fax : (852) 2517 1797  
 http://www.toyo-led.com E-mail : sales@toyo-led.com



**P/N: TY-Y0603UR1(0.60)**

0603 Package 1.6\*0.8mm Surface Mount LEDs Series

## ◇ Reliability Test Items And Conditions

NO.	Item	Test Condition	Test Hr/cycle/time	Sample Q'ty	Ac/Re
1	Reflow	TEMP:260±5 ; Min.5Sec	6 min	22pcs	0/1
2	Temperature Cycle	H:+100 15mins To(5mins) L:-40 15mins	300 cycles	22pcs	0/1
3	Thermal Shock	H:+100 15mins To(5mins) L:-40 15mins	300 cycles	22pcs	0/1
4	Low Temperature Storage	TEMP:-40	1000hrs	22pcs	0/1
5	DC Operating Life	IF=20MA	1000hrs	22pcs	0/1
6	High Temperature	85	1000hrs	22pcs	0/1
7	High Humidity	85%R.H.	1000hrs	22pcs	0/1

## ◇ SMT Reflow Soldering Instructions

Number of reflow process shall be than 2 times and cooling  
 Process to normal temperature is required between first and second  
 soldering process

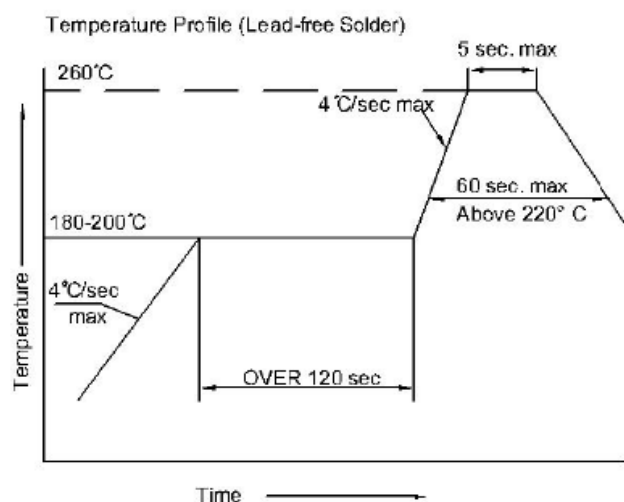
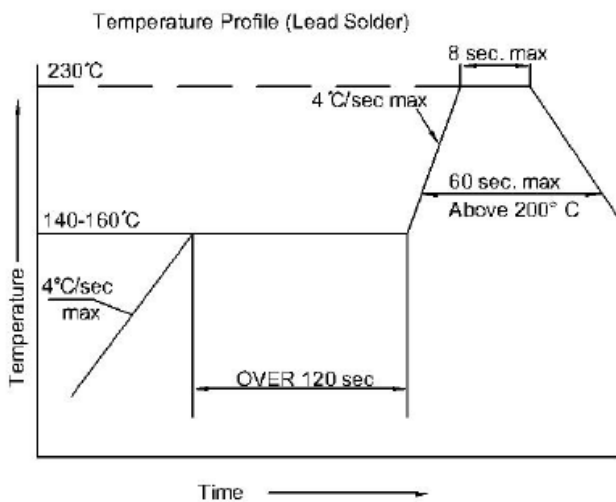



# TOYO LED ELECTRONICS LIMITED

Room 1610, Hong Kong Plaza, 188 Connaught Road West, Hong Kong.  
Tel : (852) 2540 7288 Fax : (852) 2517 1797  
http://www.toyo-led.com E-mail : sales@toyo-led.com



**P/N: TY-Y0603UR1(0.60)**

0603 Package 1.6\*0.8mm Surface Mount LEDs Series

### ◇ Recommended Soldering Pad Dimensions

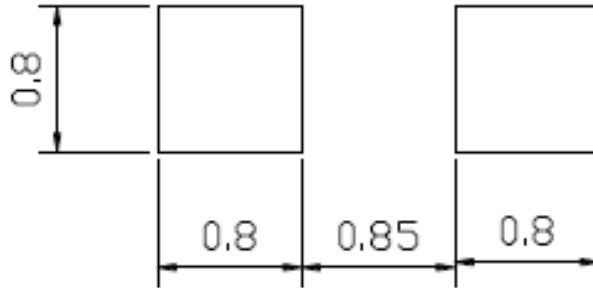

### ◇ Tape Specification: 4,000PCS per reel

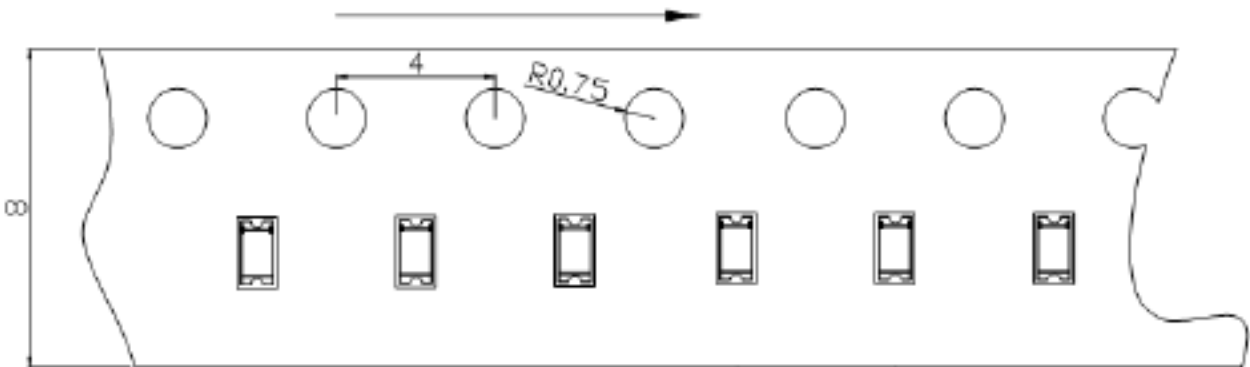

### ◇ Package Label

<b>SMD LED</b>		
PART NO: _____		QA Pass
LOT NO : _____		
Q' TY : _____		
VF : _____	IV : _____	
WL : _____	BIN: _____	Pb
DATA : _____		
TOYO LED ELECTRONICS LIMITED		
Website: <a href="http://www.toyo-led.com">http://www.toyo-led.com</a> E-mail: <a href="mailto:sales@toyo-led.com">sales@toyo-led.com</a>		



# TOYO LED ELECTRONICS LIMITED

Room 1610, Hong Kong Plaza, 188 Connaught Road West, Hong Kong.  
Tel : (852) 2540 7288 Fax : (852) 2517 1797  
http://www.toyo-led.com E-mail : sales@toyo-led.com



**P/N: TY-Y0603UR1(0.60)**

0603 Package 1.6\*0.8mm Surface Mount LEDs Series

## ❖ Package & Shipping Instructions

