

特性 FEATURES

- 40A & 60A 触点切换能力
- 具有四种触点形式
- 多种安装方式
- 防尘罩和塑封型可供选择
- 外形尺寸: 27.8 × 27.8 × 25.1mm

- 40A & 60A switching capability
- 4 kinds of contact arrangement available
- Various mounting terminations available
- Dust protected type and sealed type available
- Outline dimensions: 27.8 × 27.8 × 25.1mm

触点参数 CONTACT PARAMETERS

触点形式	Contact Arrangement	1A、1B、1C	2A
触点材料	Contact Material	银合金 Silver Alloy	
接触压降 (初始)	Voltage Drop(Initial)	NO: 典型值 Typ. 40mV, 最大值 Max. 300mV (at 10A) NC: 典型值 Typ. 40mV, 最大值 Max. 300mV (at 10A)	
最大连续电流	Max. Continuous Current	NO/NC: 40A/30A	NO/NC: 60A/45A
最大切换电压	Max. Switching Voltage	80VDC	
电气寿命	Electrical Life	1 × 10 ⁵ 次 OPS	
机械寿命	Mechanical Life	1 × 10 ⁶ 次 OPS	

性能参数 FUNCTION PARAMETERS

绝缘电阻	Insulation Resistance	100MΩ (500VDC)
介电耐压	Dielectric Strength	触点与线圈间 Between Coil & Contacts: 500VAC 1min 断开触点间 Between Open Contacts: 500VAC 1min
动作时间	Operate Time	≤10ms
释放时间	Release Time	≤5ms
环境温度	Ambient Temperature	-40℃ ~+125℃
振动	Vibration	10Hz~500Hz, 49m/s ² (5G)
冲击	Shock	稳定性 Functional: 98m/s ² (10G) 强度 Destructive: 196m/s ² (20G)
引出端方式	Terminal Form	快速连接式引出端 QC
封装形式	Construction	防尘罩型 Dust Protected, 塑封型 Sealed
重量	Unit Weight	约 Approx.: 35g
机械性能	Mechanical Data	外壳保持力: (拉和压) 200N Cover Retention: (Pull & Push) 200N 引出脚保持力: (拉和压) 100N Terminal Retention: (Pull & Push) 100N 引出脚抗弯曲力: (各方向) 10N Terminal Resistance To Bending (Front & Side) 10N

线圈规格表 COIL DATA(23℃)

额定电压 Rated Voltage VDC	动作电压 Operate Voltage VDC	释放电压 Release Voltage VDC	线圈电阻 Coil Resistance Ω ± 10%	线圈功率 Coil Power W	并联电阻 Parallel Resistance Ω ± 10%	等效电阻 Equivalent Resistance Ω ± 10%	允许最大线圈电压 ⁽¹⁾ Max Allowable Overdrive Voltage VDC	
							20℃	85℃
6	≤4.2	≥0.6	22	1.7	-	-	10.1	7.9
6	≤4.2	≥0.6	22	1.9	180	20	10.1	7.9
12	≤8.4	≥1.2	85	1.7	-	-	20.2	15.7
12	≤8.4	≥1.2	85	1.9	680	75.5	20.2	15.7
24	≤16.8	≥2.4	340	1.7	-	-	39.5	31.5
24	≤16.8	≥2.4	340	1.9	2700	302	39.5	31.5
24	≤16.8	≥2.4	255	2.3	-	-	39.5	31.5

注意: (1) 触点无负载电流、线圈电阻为最小值情况下, 继电器线圈允许施加的最大连续工作电压。
 Note: (1) Max. Allowable overdrive voltage is stated with no load applied minimum coil resistance.

负载参数 LOAD DATA

负载电压 Load Voltage	负载类型 Load Type		触点负载电流 Load Current A			通断比 On/Off Ratio S		电耐久性 (次) Electrical Endurance OPS	试验环境温度 Ambient Temp.
			1C		1A	接通 On	断开 Off		
			常开 NO	常闭 NC	常开 NO				
14VDC	阻性 Resistive	接通 Make	40	30	40	2	2	1 × 10 ⁵	详见电耐久性 试验环境 温度曲线 See Ambient Temp. Curve
		断开 Break	40	30	40				
	感性 Flasher	接通 Make	150	-	150	2	2		
		断开 Break	30	-	30				
	灯 Lamp	接通 Make	80	-	80	2	2		
		断开 Break	33	-	33				
27VDC	阻性 Resistive	接通 Make	20	10	20	2	2	At 23℃	
		断开 Break	20	0	20				

订货标记示例 ORDERING INFORMATION

		MAH	-S	-1	12	-C	-1	R
产品型号	Model:	MAH						
产品结构	Structure:	1: 防尘罩型 Dust Protected 2: 塑封型 Sealed						
触点组数	Contact Group:	1: 1 组 Group						
线圈电压	Coil Voltage:	12: 12VDC 24: 24VDC						
触点形式	Contact Form:	A: 常开 NO B: 常闭 NC C: 转换 NO/NC 2A: 双常开 2NO						
结构型式	Version:	1: 光背快速接引出端 Cover Without Bracket 3: 铁背快速接引出端 Cover With Metal Bracket 4: 塑背快速接引出端 Cover With Plastic Bracket						
线圈并联电阻	Coil Derived Resistance:	无 Nil: 无并联元件 No Components R: 并联电阻 With Resistor D1: 并联二极管 (阳极接 86#脚) With Parallel Diode (anode connection pin # 86) D2: 并联二极管 (阳极接 85#脚) With Parallel Diode (anode connection pin # 85)						

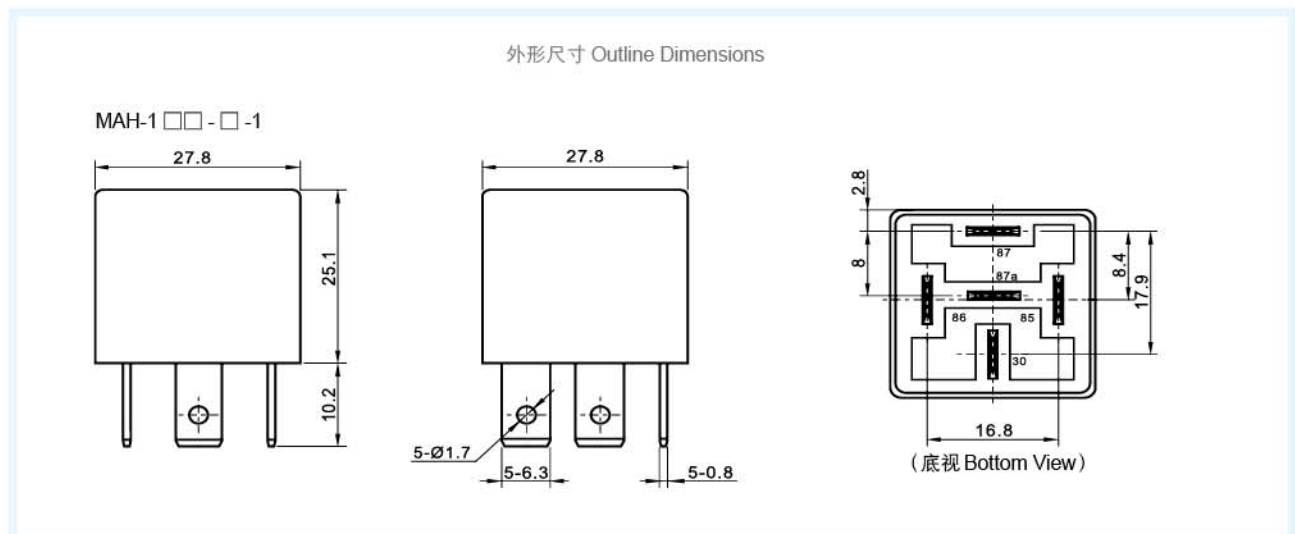
外形尺寸、接线图、安装孔尺寸 OUTLINE DIMENSIONS, WIRING DIAGRAM AND PCB LAYOUT (单位 Unit: mm)

外形尺寸 Outline Dimensions

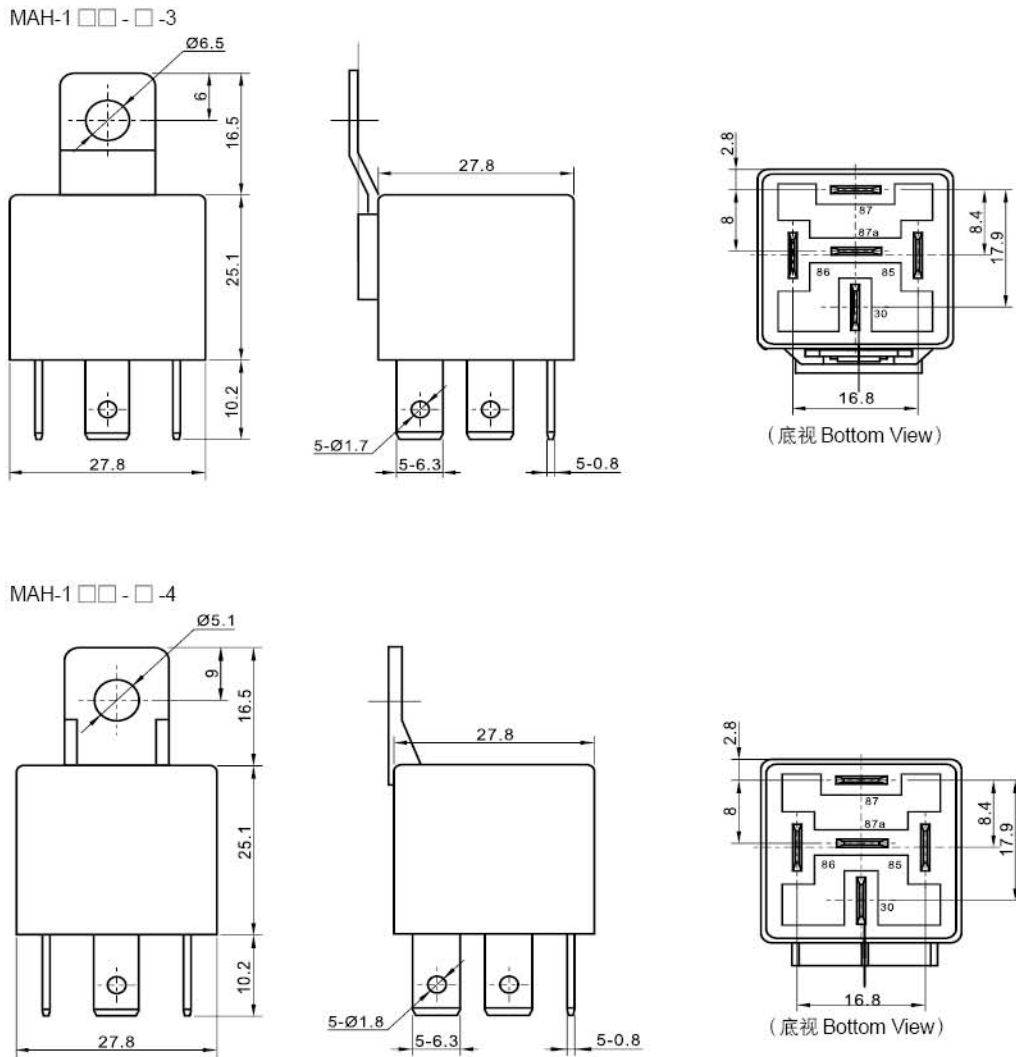

备注:

- (1) 产品部分外形尺寸未注尺寸公差, 当外形尺寸 $\leq 1\text{mm}$, 公差为 $\pm 0.2\text{mm}$; 当外形尺寸在 $1\sim 5\text{mm}$ 之间时, 公差为 $\pm 0.3\text{mm}$; 当外形尺寸 $> 5\text{mm}$ 时, 公差为 $\pm 0.4\text{mm}$;
 (2) 安装孔尺寸中未注尺寸公差均为 $\pm 0.1\text{mm}$.

REMARK:

- (1) In case of no tolerance shown in outline dimension: outline dimension $\leq 1\text{mm}$, tolerance should be $\pm 0.2\text{mm}$; outline dimension $> 1\text{mm}$ and $\leq 5\text{mm}$, tolerance should be $\pm 0.3\text{mm}$; outline dimension $> 5\text{mm}$, tolerance should be $\pm 0.4\text{mm}$;
 (2) The tolerance without indicating for PCB layout is always $\pm 0.1\text{mm}$.

接线图 Wiring Diagram (底视 Bottom View)

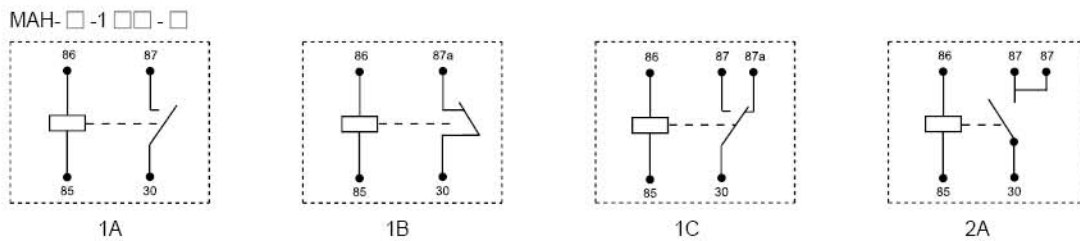

接线图 Wiring Diagram (底视 Bottom View)

MAH-□-1□□-□-□R

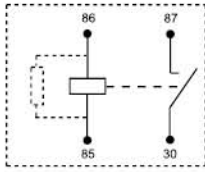

1A

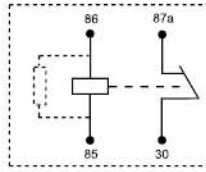

1B

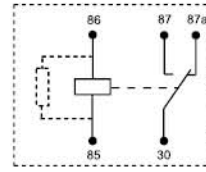

1C

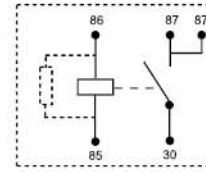

2A

MAH-□-1□□-□-□D1

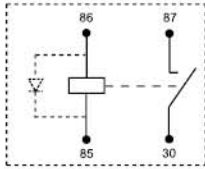

1A

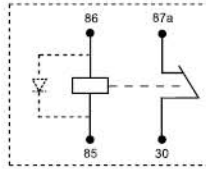

1B

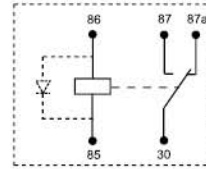

1C

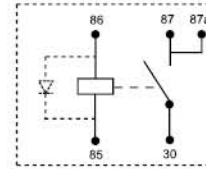

2A

MAH-□-1□□-□-□D2

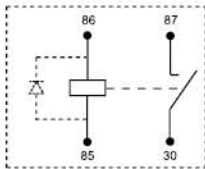

1A

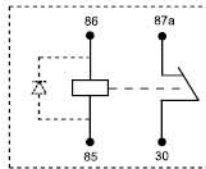

1B

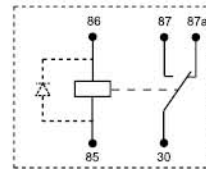

1C

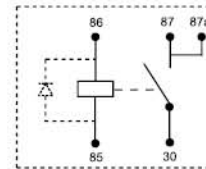

2A

性能曲线图 PERFORMANCE CURVE

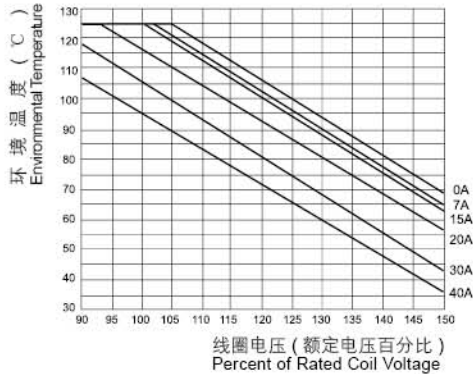
 1. 线圈连续通电电压范围
Coil Continuous Voltage Range

说明:

- (1) 继电器线圈施加最大连续工作电压时, 触点应没有负载。
- (2) 动作电压与线圈预通电电压有关, 预通电后检查动作电压, 其值会变大
- (3) 线圈最大允许温度为 180℃, 考虑到电阻法所测量的线圈温升是平均值, 推荐在不同使用环境、不同线圈电压、不同负载条件下测量时, 线圈温度应小于 170℃。
- (4) 当线圈实际工作电压超出曲线规定范围时, 请联系美硕并提供相应详细使用条件。

(1) There should be no contact load applied when maximum continuous operation voltage is applied on coil.

(2) The operating voltage is connected with coil pre-energized time and voltage. After pre-energized, the operating voltage will increase.

(3) The maximum allowable coil temperature is 180 °C. For the coil temperature rise which is measured by resistance is average value, we recommend the coil temperature should be below 170 °C under the different application ambient, different coil voltage and different load etc.

(4) If the actual operating coil voltage is out of the specified range please contact meishuo for further details.

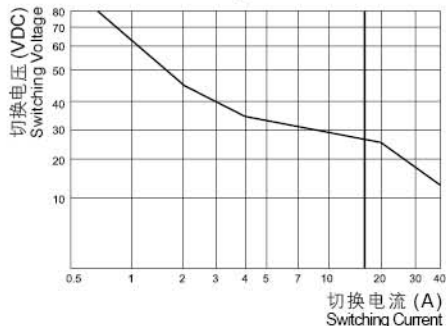
 2. 允许最大负载范围
Maximum Load Range

说明:

- (1) 本图以常开触点为例, 本图电流为阻性。
- (2) 产品按接触点参数表进行负载与耐久性试验, 当实际使用的负载电压、电流、动作频率任一项与触点参数表不同时, 请重新进行确认试验。

(1) This chart takes NO contact. Resistive load as example.

(2) The load and electric endurance tests are made according to "CONTACT DATA" parameters table. If actual load voltage, current, or operate frequency is different from "CONTACT DATA" table, please arrange corresponding tests for confirmation.

性能曲线图 PERFORMANCE CURVE

3. 电耐久试验环境温度曲线
Ambient Temperature Curve of the Electrical Endurance Test

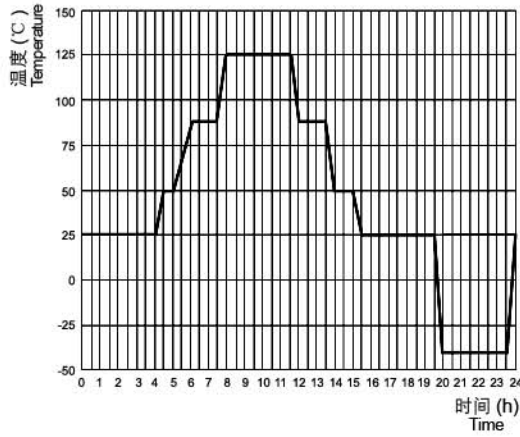

说明:
(1) 最低温度为 -40℃
(2) 最高温度为 125℃

(1) The minimum temperature is -40℃
(2) The maximum temperature is 125℃

声明 STATEMENT:

本产品规格书仅供客户使用时参考,若有更改,恕不另行通知。

客户应根据具体的使用条件选择与之相匹配的产品。如有疑问,请与美硕联系获取更多的技术支持,但产品选型责任由客户承担。

This product specification is for reference only to customers, subject to change without notice.

The customer should select the matching product according to the use condition. Any questions, please feel free contact us to get more technical support. However, product selection responsibility only by the customer.

© Copyright Zhejiang MEISHUO Electric Technology Co.,Ltd. All right reserved.