

Features:

- ◆ High intensity
- ◆ Polygonal super flux led & piranha led
- ◆ General purpose leads
- ◆ Reliable and rugged

Package Dimensions:

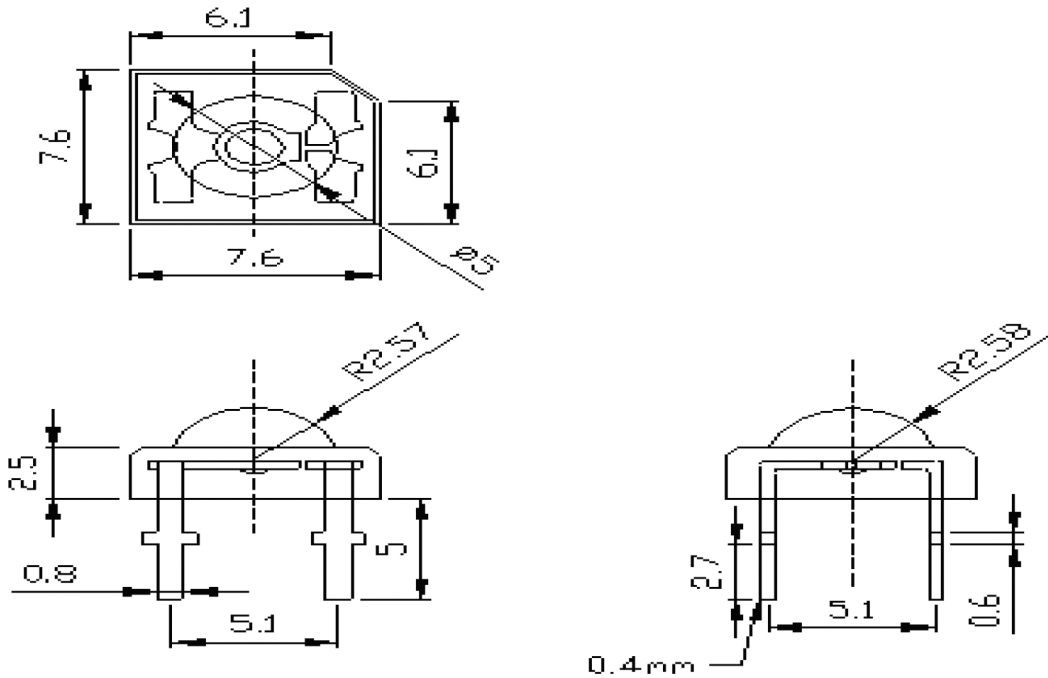

Part No.	Chip Material	Lens Color	Source Color
	InGaN	Water Clear	Super Blue

Notes:

1. All dimensions are in millimeters (inches).
2. Tolerance is $\pm 0.25\text{mm}$ (.010") unless otherwise noted.
3. Protruded resin under flange is 1.0mm (.04") max.
4. Lead spacing is measured where the leads emerge from the package.
5. Specifications are subject to change without notice.
6. Precautions for **ESD**:

STATIC SHIELD Electricity and surge damages the **LED**. It is recommended to use a wrist band or anti-electrostatic glove when handling the **LED**. All devices, equipment and machinery must be properly grounded.

7. This data-sheet only valid for six months.

Absolute Maximum Ratings at Ta=25°C

Parameter	MAX.	Unit
Power Dissipation	100	mW
Peak Forward Current (1/10 Duty Cycle,0.1ms Pulse Width)	100	mA
Continuous Forward Current	20	mA
Derating Linear From 50°C	0.4	mA/°C
Reverse Voltage	5	V
Operating Temperature Range	-40°C to +80°C	
Storage Temperature Range	-40°C to +80°C	
Lead Soldering Temperature [4mm(.157")From Body	260°C for 5 Seconds	

Electrical Optical Characteristics at Ta=25°C

Parameter	Symbol	Min.	Typ.	Max	Unit	Test Condition
Luminous Intensity	I_V	800	--	1200	Mcd	$I_f=20\text{mA}$ (Note 1)
Viewing Angle	$2\theta_{1/2}$		90		Deg	(Note 2)
Peak Emission Wavelength	λ_p	--		--	nm	$I_f=20\text{mA}$
Dominant Wavelength	λ_p	465	--	470	nm	$I_f=20\text{mA}$ (Note 3)
Forward Voltage	V_f	2.8	3.0	3.2	V	$I_f=20\text{mA}$
Reverse Current	I_R	---	---	10	μA	$V_R=5\text{V}$

Notes:

1. Luminous intensity is measured with a light sensor and filter combination that approximates the CIE eye-response curve.
2. $\theta_{1/2}$ is the off-axis angle at which the luminous intensity is half the axial luminous intensity.
3. The dominant wavelength(λ_d) is derived from the CIE chromaticity diagram and represents the single wavelength which defines the color of the device.