

# Double PWC Lift

## Assembly Instructions

### RECOMMENDED TOOLS



Wrenches or sockets:  
M14 (or 13/32")  
M15 (or 5/8")  
M19 (or 3/4")



Cordless Drill



Rubber Mallet



Screwdriver  
(Phillips)



Work Gloves

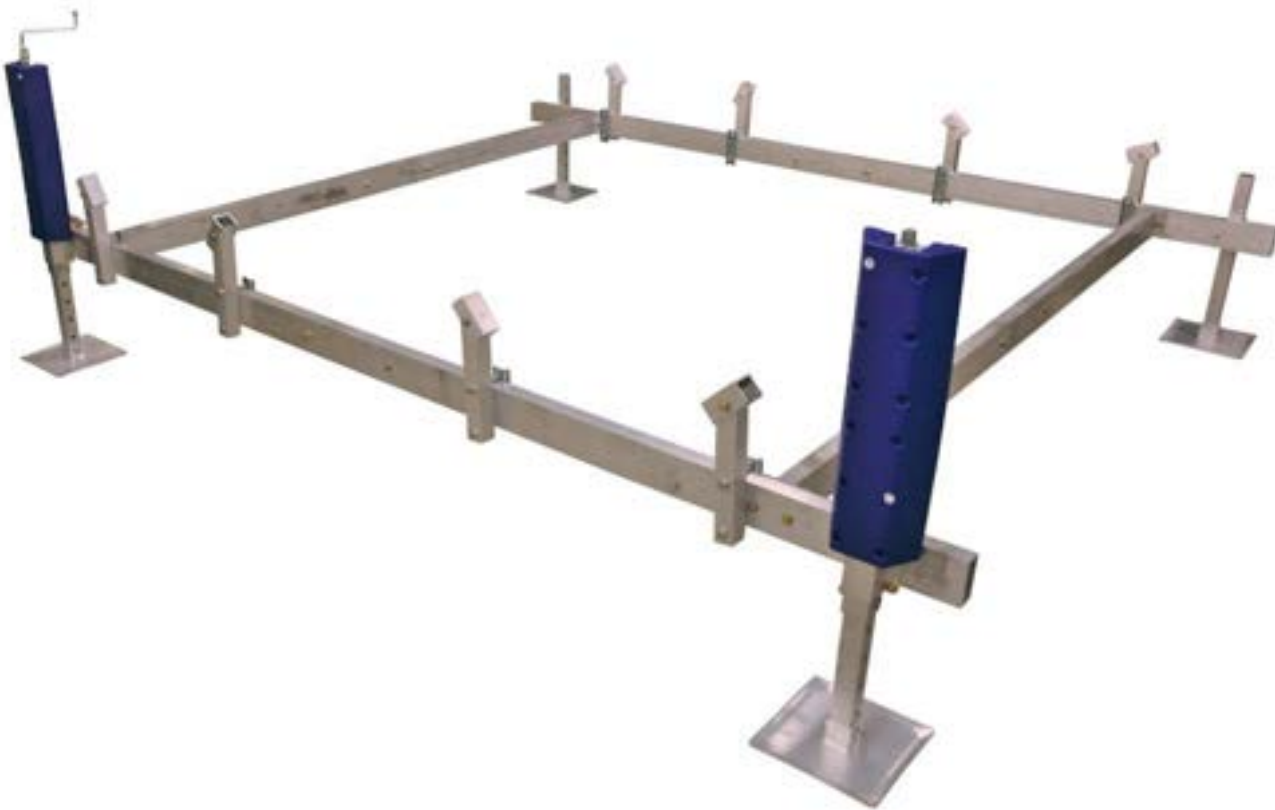

# Double PWC Lift

## Components

	Part Number	Description	Qty.
A	10920-11	Stationary Tube w/ Bracket (1.5"x3.5"x60")	2
B	10920-11	Lift Tube (1.5"x3.5"x60")	2
C	10920-31	Stringer Tube (1.5"x3.5"x48")	4
D	10920-12	Splice Tube Insert	4
E	10920-4	Assembly Angles (2"x2")	8
F	10920-52	12" Bunk Vertical Support	8
G	10920-51	Bunk Mounting Bracket	8
H	10920-53	Bunk Backer Plate	8
I	10477	Speed Crank Handle	1
J	10855	Drop Leg Assembly (Leg/Base)	4
K	10840	Aluminum Leveler	2
L	10920-7	Aluminum Backer Plate	2
M	10886	Blue Fenders	2

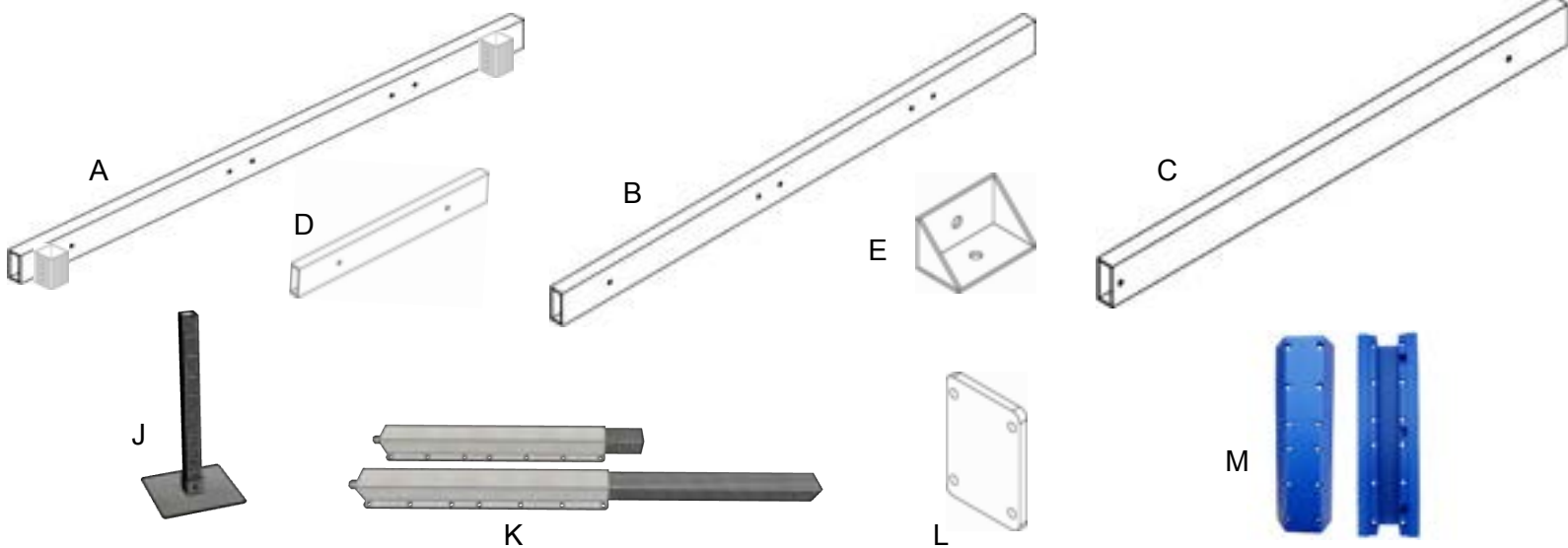
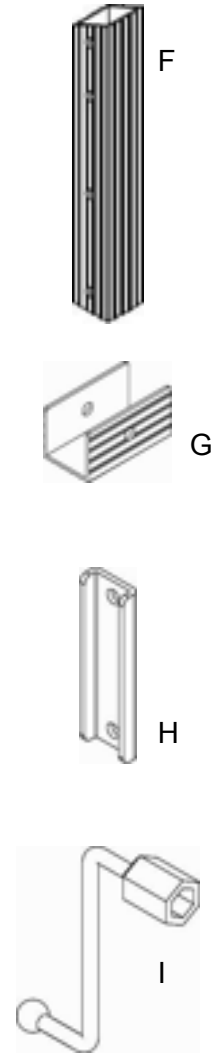

# Double PWC Lift

Hardware

HARDWARE			
	SIZE	LABEL	QTY
AA	M10x60mm	Frame Assembly	20
BB	M10x75mm (Nylon bolt/nut)	Bumper Hardware Kit (BB)	4
CC	M10x60mm	Bunk Bracket (bagged w/ Nylock Nuts)	8
DD	M10x70mm	Jack Mounting	8
EE	M12x60mm	Drop Leg	8
FF	M10x100mm	Bunk Mounting	16
GG	M4.5x25mm	Pan Head Screw	16

## Electric Remote Option (PN10450D):

Operate the manual boat lift with a touch of a button while in the boat or on the dock with this 12-volt DC remote control electric motor kit. Turn the boat lift into a kayak or PWC launch using the remote control.

This kit includes two electric motor bracket assemblies, a control box, a battery mounting assembly, heavy duty waterproof underwater SO cable and a remote control. Battery and battery box not included.

Simply remove the leveler top nut and install the motor assembly to each leveler, route the SO cables to the motors and connect power.



# Double PWC Lift

## Assembly Steps

- 1 Use the Splice Tube Inserts (D) to assemble the Lift Tube (B), Stationary Tube w/ Bracket (A) and Stringer Tubes (C). Fasten using M10x60mm bolts and Serrated Flange Nuts (AA-Frame Assembly).

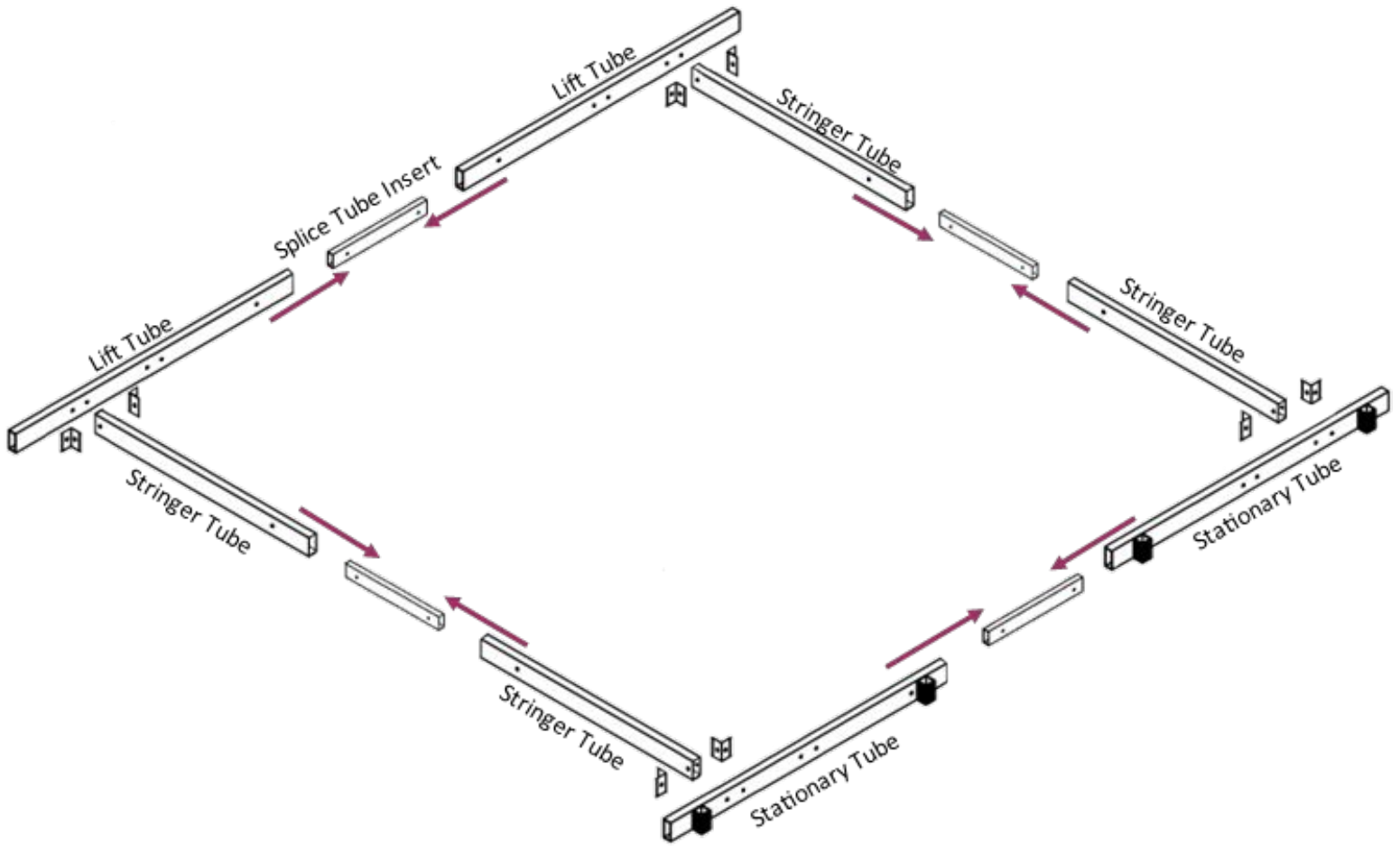

- 2 Attach the Assembly Angles (E) to each end of the assembled Stringer Tubes (C). Assembly Angles are fastened using M10x60mm bolts and Serrated Flange Nuts (AA).

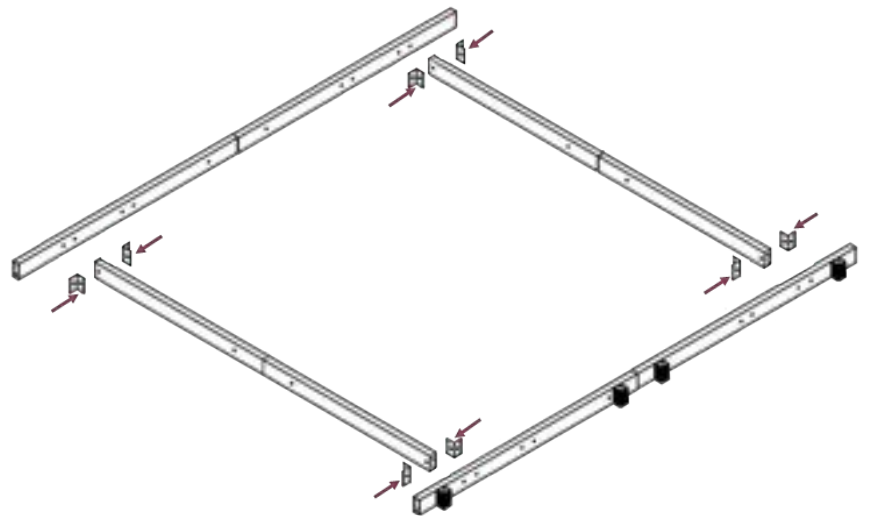

# Double PWC Lift

## Assembly Steps

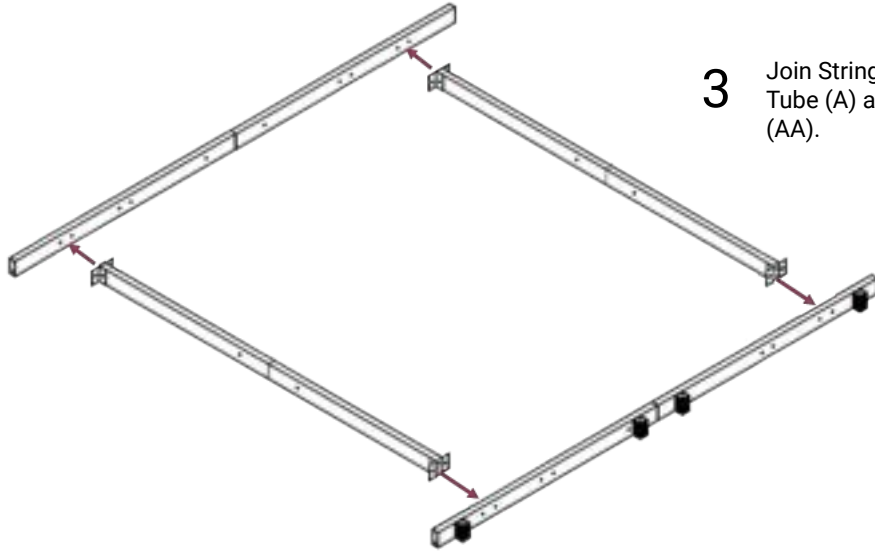

- 3** Join Stringer Tubes (C) assemblies to the Lift Tube (B) and Stationary Tube (A) assemblies using M10x60mm bolts and Serrated Flange Nuts (AA).

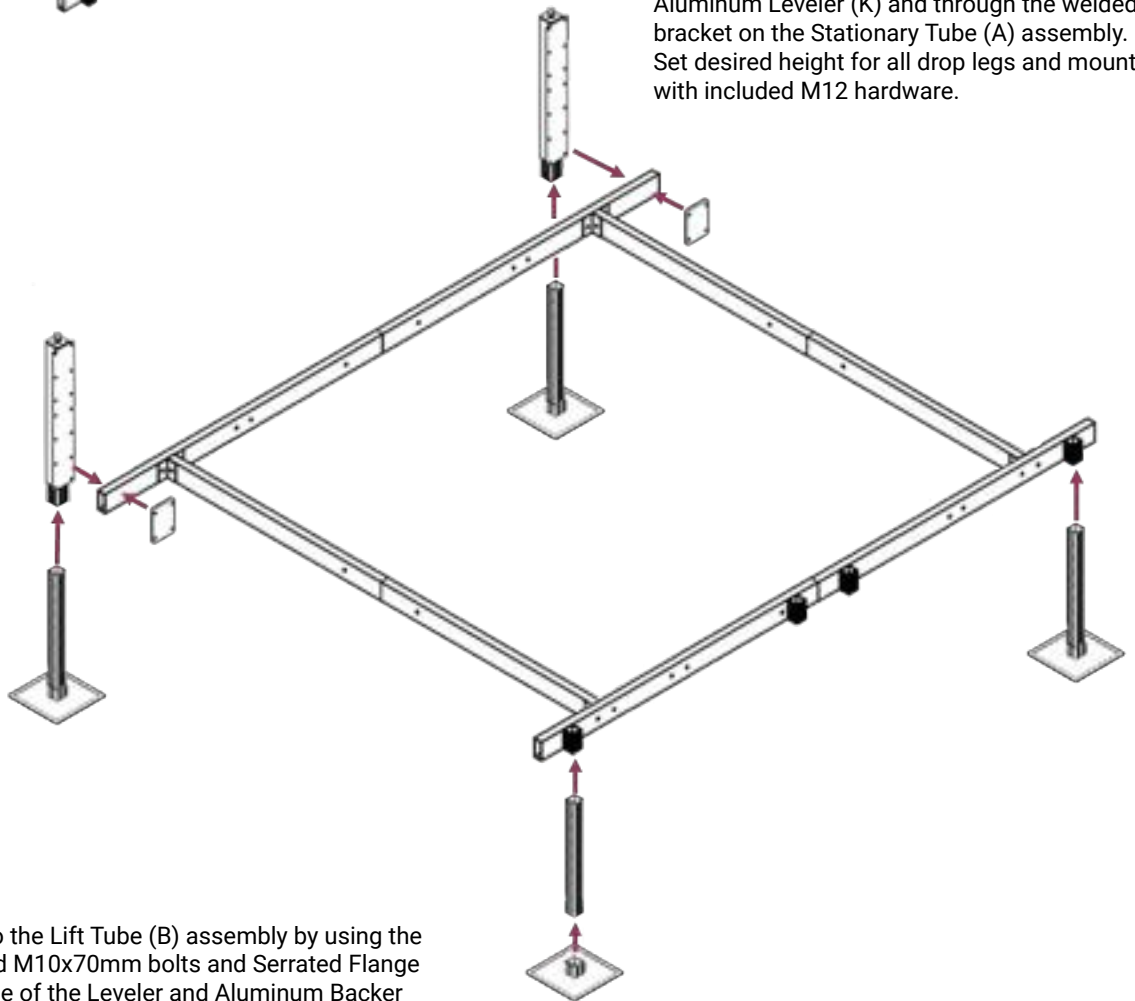

- 4** Assemble drop legs (J) by attaching Drop Leg to Bases using M12x60mm bolts and Serrated Flange Nuts (EE). Insert Drop Legs inside the Aluminum Leveler (K) and through the welded bracket on the Stationary Tube (A) assembly. Set desired height for all drop legs and mount with included M12 hardware.

- 5** Install Aluminum Leveler (K) to the Lift Tube (B) assembly by using the Aluminum Backer Plate (L) and M10x70mm bolts and Serrated Flange Nuts (DD). The mounting flange of the Leveler and Aluminum Backer Plate clamp around the Lift Tube assembly. Generally, mount Leveler flush with outside edge of Lift Tube.

# Double PWC Lift

## Assembly Steps

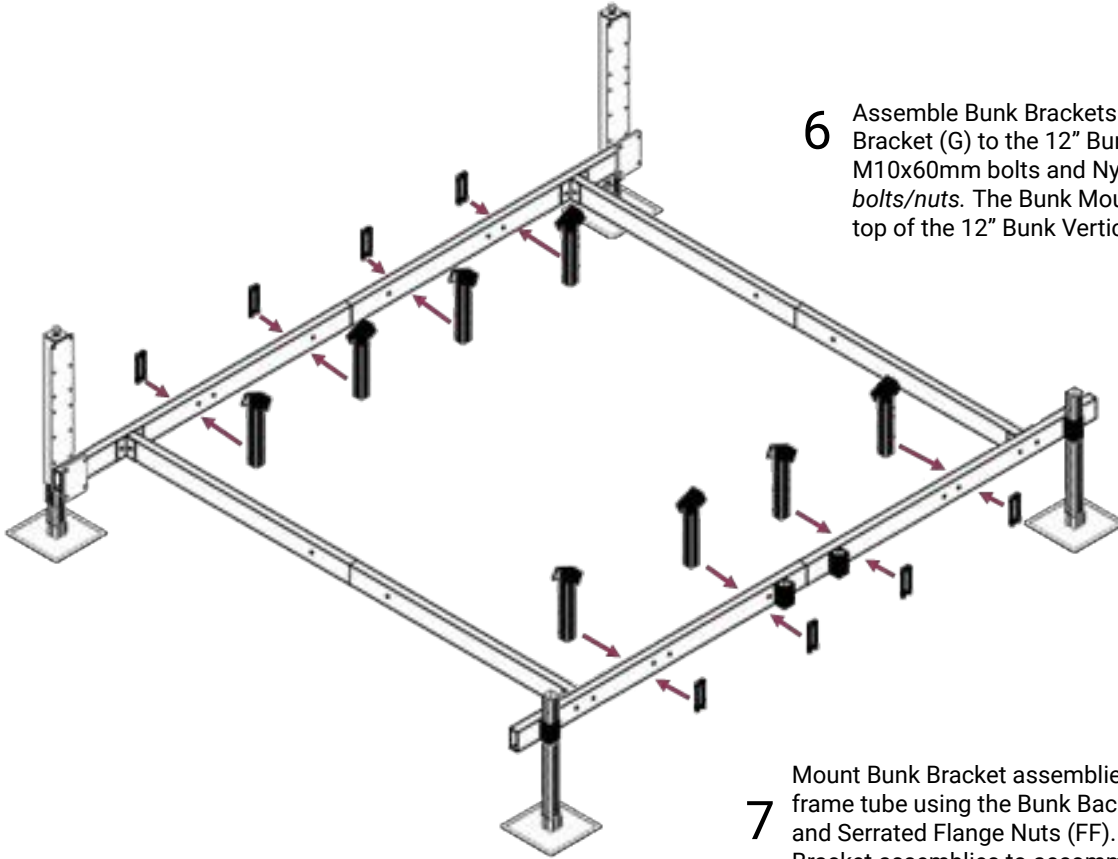

- 6 Assemble Bunk Brackets by attaching the Bunk Mounting Bracket (G) to the 12" Bunk Vertical Support (F) with M10x60mm bolts and Nylock Nuts (CC). *Do not over-tighten bolts/nuts.* The Bunk Mounting Bracket should pivot freely on top of the 12" Bunk Vertical Support.

- 7 Mount Bunk Bracket assemblies to the frame by clamping around the frame tube using the Bunk Backer Plate (H) and M10x100mm bolts and Serrated Flange Nuts (FF). Adjust the space between Bunk Bracket assemblies to accommodate the hull of the watercraft. Tighten all bolts/nuts.

- 8 Screw wood bunks (not included) to Bunk Mounting Brackets (G) using two pan head screws (GG). To install, lay out wood bunks on assembled lift. Screw bunks into the Bunk Mounting Bracket. Alternatively, trace location of the Bunk Mounting Brackets on the wooden bunk, remove to screw the bunks in place, and mount the assembly to the lift. Attach the two Blue Bumpers (M) to the Levelers (K) using Nylon Hardware (BB).

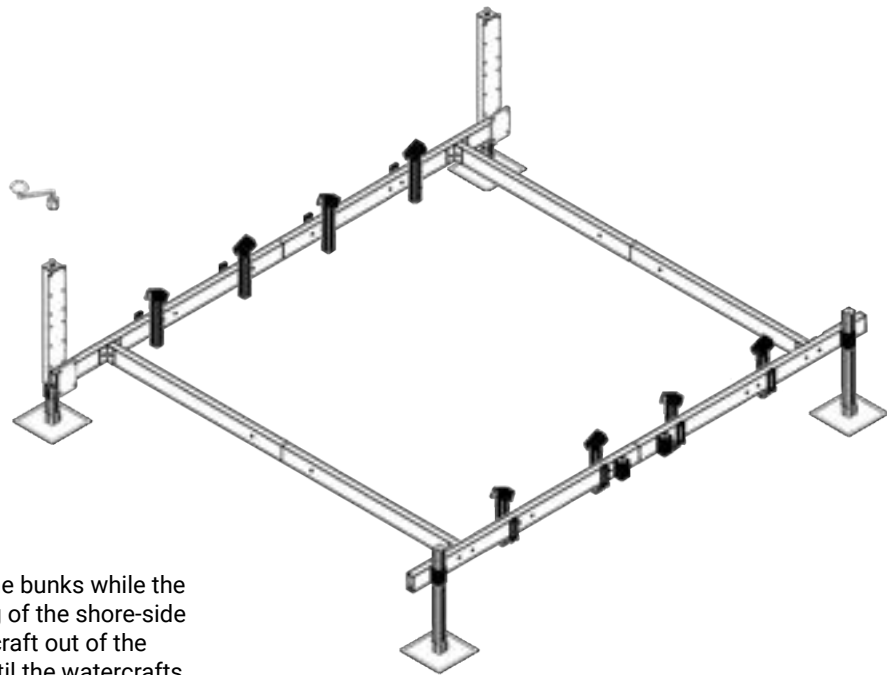

- 9 Operate the Boat Lift by guiding your watercrafts onto the bunks while the levelers are in the lowest position. Make sure the setting of the shore-side drop legs are high enough to keep the bow of the watercraft out of the water when resting on the lift. Then raise the levelers until the watercrafts are out of the water. Each leveler is operated independently, so raise or lower each leveler about 6" at a time.