

SB-PFRDC200S

SB Fitness Equipment

PEC FLY / REAR DELT COMBO MACHINE



SB

Owners Manual
and Assembly Guide

PARTS DIAGRAM EXPLODED VIEW

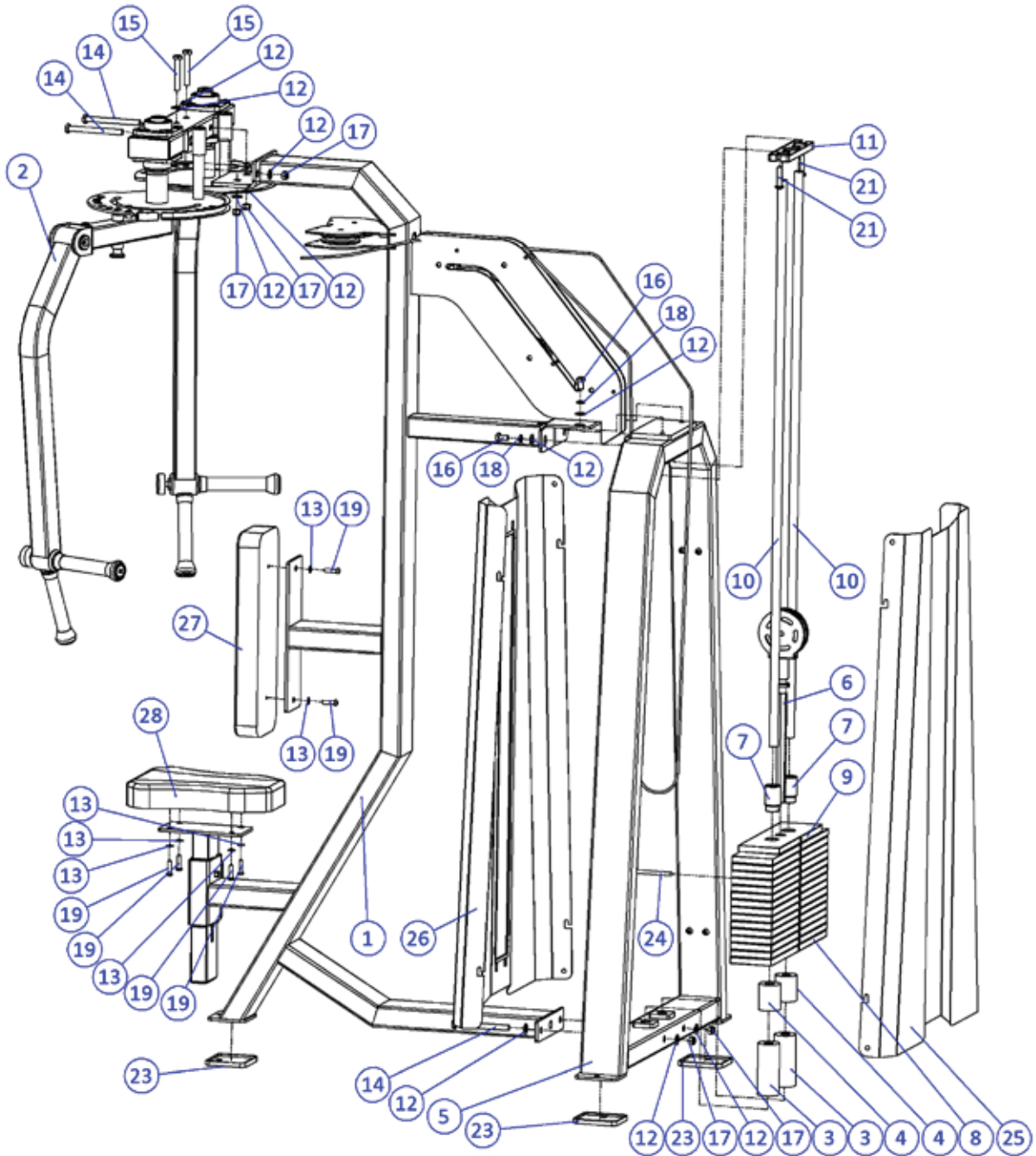

PARTS LIST AND PART NUMBERS

SERIAL NUMBER	PART NUMBER	SPAR PART NAME	STANDARD SIZES	AMOUNT (PIECE)
1	100	MAIN FRAME ASSEMBLY		1
2	300	BOOM COMBINATION		1
3	W7027	COUNTERWEIGHT SUPPORT PIPE		2
4	W7011	SHORT COUNTERWEIGHT SUPPORT PIPE.		2
5	700	DOOR FRAME COMBINATION		1
6	----	ADJUSTING SHAFT COMBINATION OF MOVABLE PULLEY.		1
7	W7031	TOP CUSHION CYLINDER.		2
8	W7023	COUNTERWEIGHT SHEET		14
9	W7025	TOP SHEET ON COUNTERWEIGHT SHEET.		1
10	G7008	GUIDE BAR		2
11	W7005	GUIDE ROD FIXING PLATE		1
12	S5301	FLAT GASKET	T1.5*D13*D24	16
13	S5304	FLAT GASKET	T1*D8*D16	6
14	S5108-06	OUTER HEXAGON SCREW.	M12*130	4
15	S5108-01	OUTER HEXAGON SCREW.	M12*75	2
16	S5108-03	OUTER HEXAGON SCREW.	M12*20	4
17	S5203	LOCKNUT	M12	6
18	S5702	SPRING WASHER	D12.5*D18*T2.5	4
19	S5110-04	HEXAGON SOCKET HEAD SCREW.	M8*30	6
20	S5110-01	HEXAGON SOCKET HEAD SCREW.	M8*16	8
21	S5103-06	HEXAGON SOCKET HEAD SCREW.	M10*45	2
22	S5120-03	TOP THREAD M8	M8*16	3
23	W7009	BOTTOM FOOT PAD		3
24	W7026	ADJUSTING BOLT OF COUNTERWEIGHT PLATE.		1
25	B7042	OUTER CASING		1
26	B7041	INNER GUARD PLATE		1
27	-----	CUSHION		1
28	-----	UNIVERSAL SMALL CUSHION.		1

INSTALLATION DETAILS

STEP 1: ATTACH THE WEIGHT STACK FRAME ASSEMBLY(5) TO THE MAIN FRAME ASSEMBLY UPRIGHT AND SEAT MOUNT(1). INSTALL THE RUBBER FOOT PADS AT THIS TIME. (OPTIONAL)

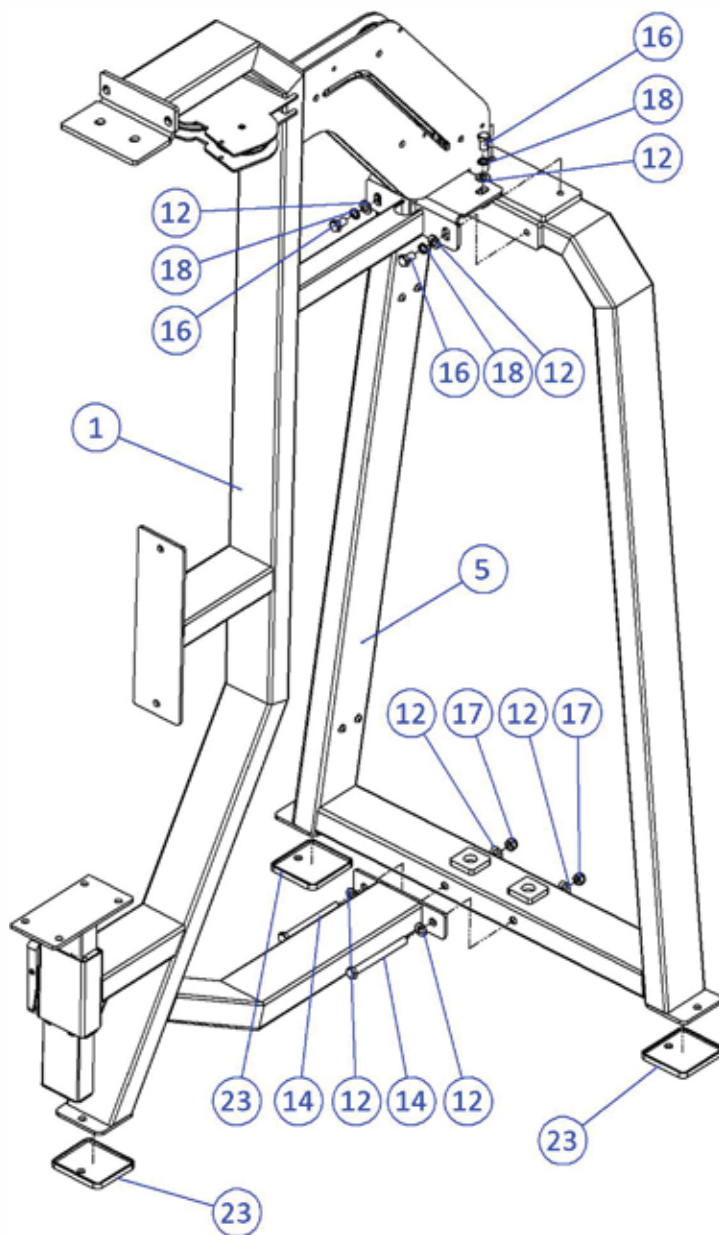

INSTALLATION DETAILS

STEP 2:

- 1.) INSTALL GUIDERODS(7) INTO HOLES LOCATED INSIDE BOTTOM OF WEIGHT STACK FRAME.
- 2.) SLIDE #32 SPACERS ON FROM TOP OF GUIDE RODS TO HAVE 2 ON EACH GUIDE ROD AT THE BOTTOM.
- 3.) INSTALL WEIGHT PLATES(29). SMALLEST WEIGHT PLATE IS LAST AS THIS IS THE TOP PLATE.
- 4.) INSTALL #27 ON TO GUIDE ROD AND INTO TOP PLATE.
- 5.) INSTALL SELECTOR ROD(28) INTO WEIGHT STACK CENTER HOLE.
- 6.) SECURE TOP OF GUIDE RODS TO WEIGHT STACK FRAME USING #9 PLATE AND #17 BOLTS.
- 7.) PLACE SELECTOR PIN(30) INTO WEIGHT STACK.

**** REFER TO PAGE 7 & 8 FOR FURTHER ASSISTANCE****

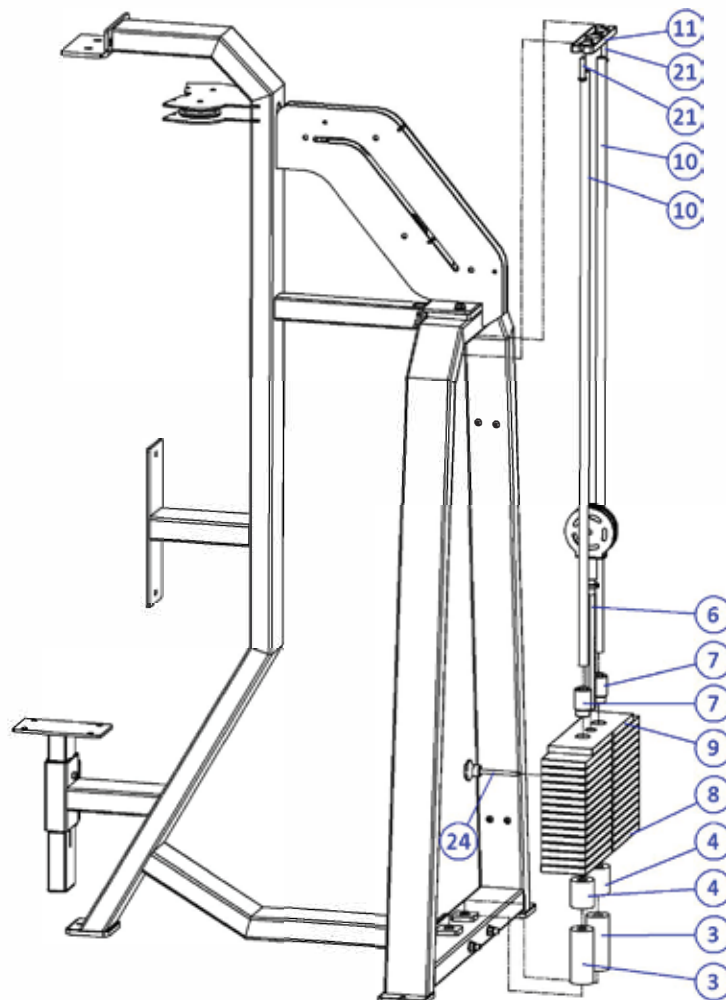

INSTALLATION DETAILS

STEP 3: INSTALL THE ARMS(2) AS SHOWN IN DIAGRAM USING #14 AND #15 BOLTS TO THE MAIN FRAME ASSEMBLY. LOOP THE CABLE STARTING ON THE CAM CONTAINING SELECTOR HOLES DOWN AND AROUND THE PULLEY ATTACHED TO THE TOP PLATE AND BACK TO THE OPPOSITE CAM CONTAINING THE SELECTOR HOLES.

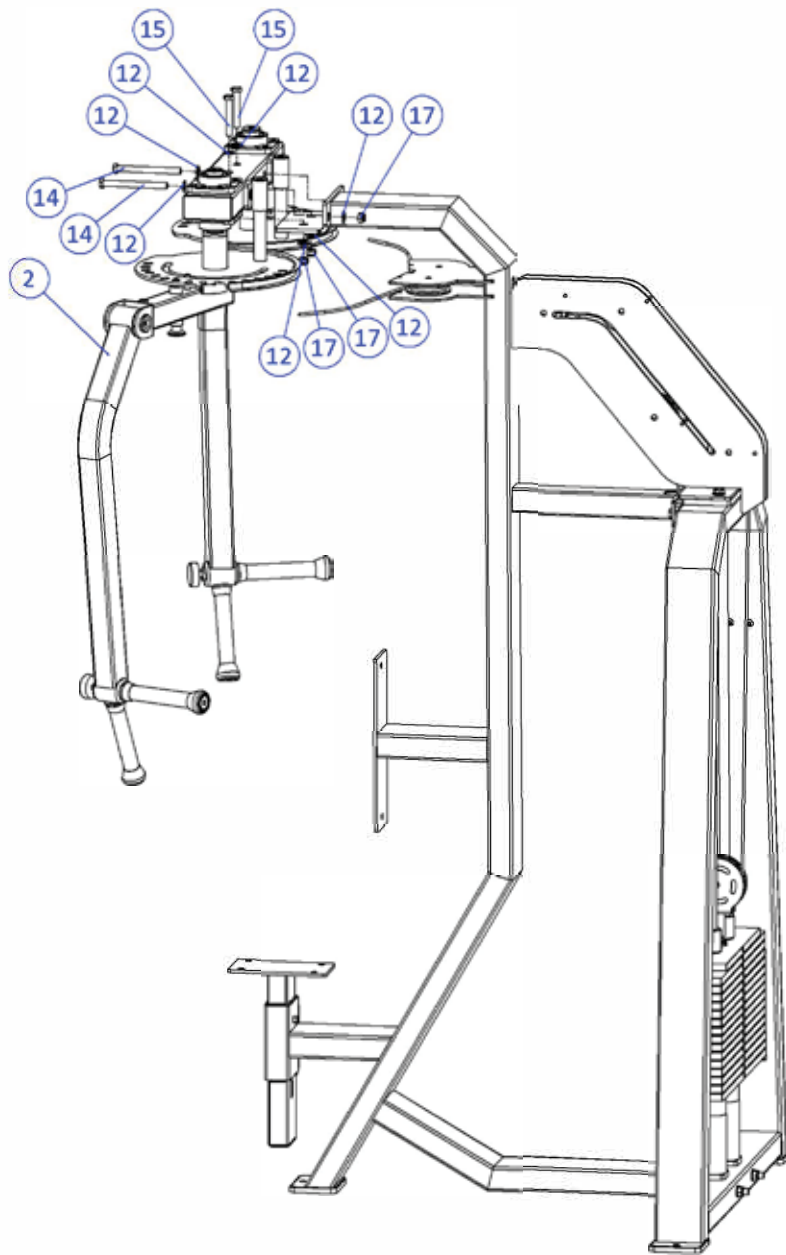

INSTALLATION DETAILS

STEP 4: INSTALL BACK AND SEAT CUSHIONS(27 & 28). INSTALL FRONT AND REAR WEIGHT STACK GUARDS(25 & 26).

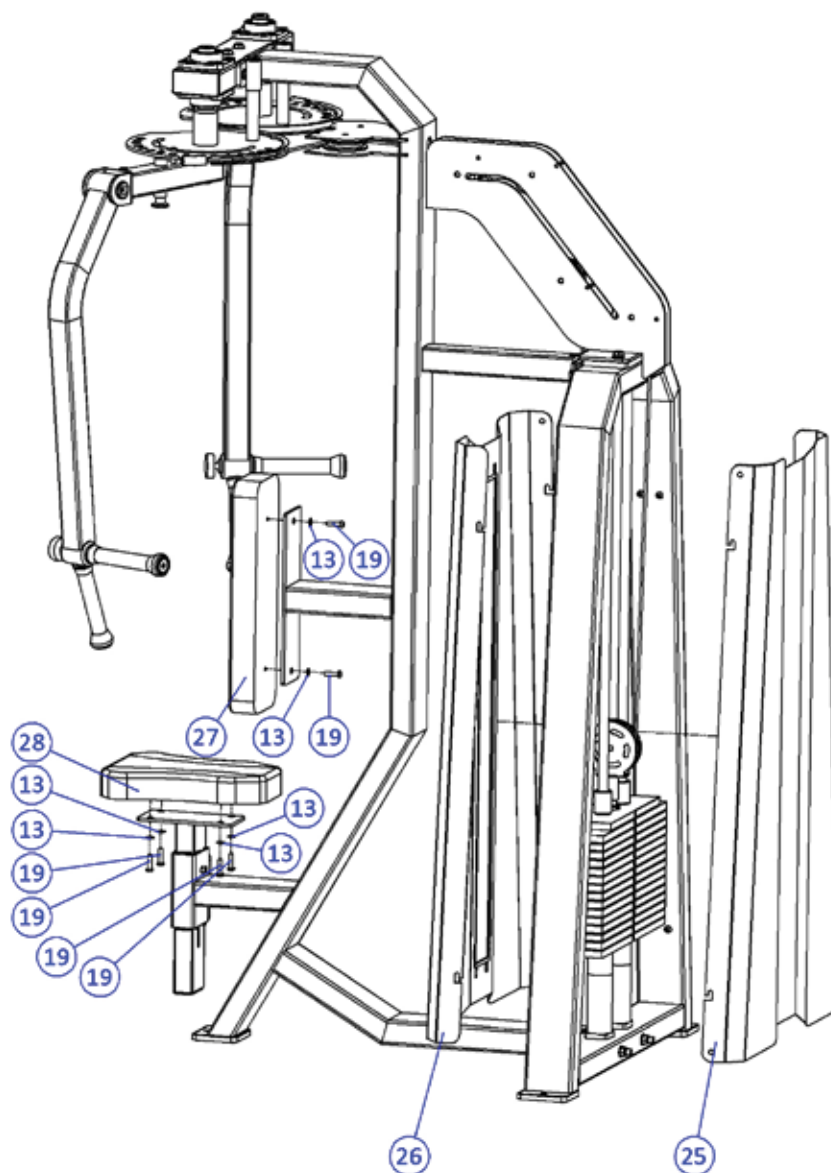

APPENDIX 1: ORIENTATION DISTINGUISHING METHOD OF COUNTERWEIGHT SHEET

THE SIDE WITH RUBBER COLLAR IS UPWARD



THE SIDE WITH THE ADJUSTING JACK FACES THE TRAINER

APPENDIX 1: INSTALLATION SEQUENCE OF COUNTERWEIGHT

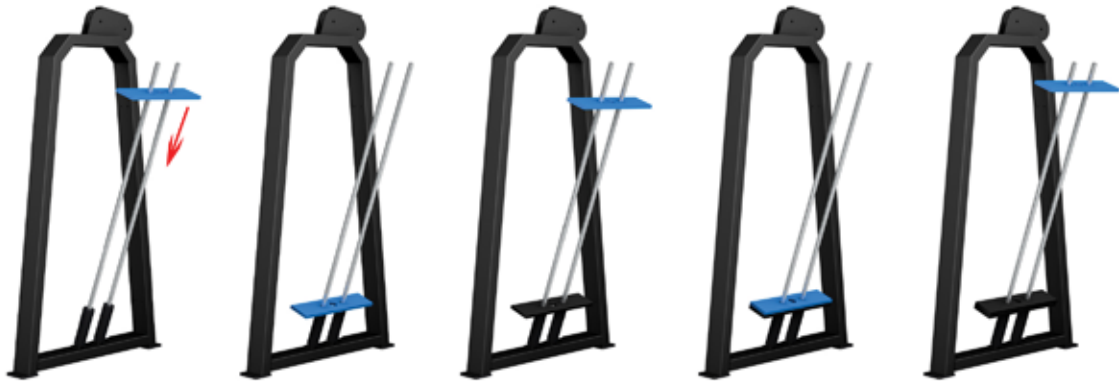

1. INSERT THE FIRST COUNTERWEIGHT PIECE FROM TOP TO BOTTOM.

2. EACH OF THE NEXT STEPS IS THE SAME AS THE FIRST.

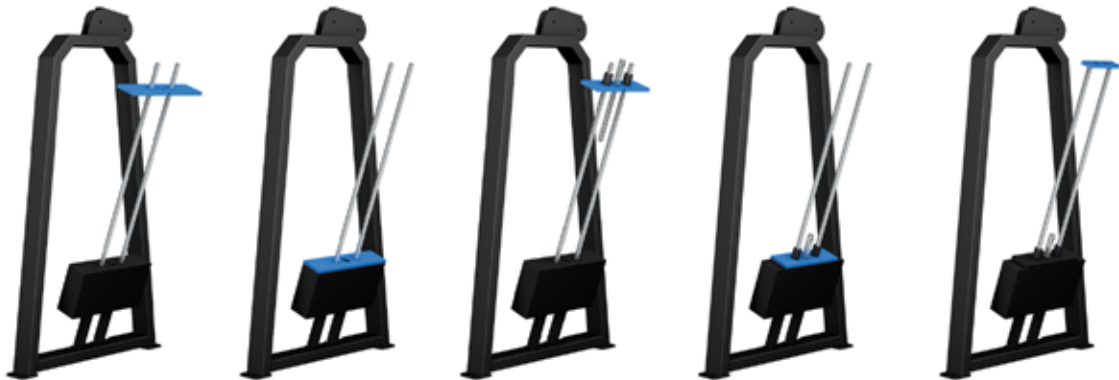

3. THE NUMBER OF INSTRUMENTS WITH SINGLE PIECE WEIGHT OF 10LB AND COUNTERWEIGHT OF 200LB IS $19 + 1$ (HEAD PIECE).

4. AFTER INSTALLING THE HEAD PIECE, PUT ON THE PLASTIC FIXING PLATE.



5. FIRST MOVE THE PLASTIC FIXING PLATE TO THE POSITION SHOWN IN THE FIGURE, AND THEN TIGHTEN IT WITH SCREWS TO COMPLETE THE WHOLE INSTALLATION PROCESS OF COUNTERWEIGHT PIECE.

INSTALL WEIGHT STACK CABLE

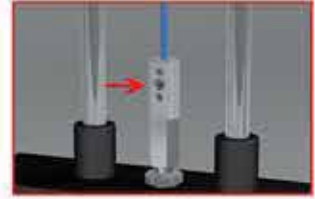

WARNING: THE SCREWS AT EACH JOINT OF THE WEIGHT STACK CABLE MUST BE FULLY TIGHTENED

PRODUCT DESCRIPTION, SPECS, & FEATURES



SB FITNESS EQUIPMENT / SB-PFRDC200S

PRODUCT NAME: : PEC FLY/REAR DELT COMBO MACHINE

WEIGHT STACK: 200LB

PRODUCT FEATURES: PECK FLY AND REAR DELT

PRODUCT DIMENSIONS: 47.75" W X 45" L X 81.5" H

MUSCLES WORKED: PECTORALIS MINOR, ANTERIOR DELTOID, REAR DELTOID, TRAPEZOID, RHOMBOIDS MAJOR AND RHOMNOIDS MINOR, UPPER LATISSIMUS DORSI

FOR YOUR SAFETY

- ◆ 1. CONSULT YOUR PHYSICIAN OR HEALTH CARE PROVIDER BEFORE USING YOUR MACHINE AND/OR EXERCISE EQUIPMENT.
- ◆ 2. IF YOU HAVE A PHYSICAL DISABILITY OR AN ATHLETIC DISABILITY, IT IS REQUIRED THAT YOU CONSULT YOUR PHYSICIAN OR HEALTH CARE PROVIDER BEFORE PROCEEDING WITH ANY EXERCISE PROGRAM.
- ◆ 3. BEFORE USING THIS PRODUCT, PLEASE READ THIS MANUAL CAREFULLY. SB FITNESS EQUIPMENT IS NOT RESPONSIBLE FOR ANY PERSONAL INJURY OR DAMAGE CAUSED BY USING THIS PRODUCT UNDER ANY CIRCUMSTANCES OR NEGLIGENCE CAUSED BY THE USER.

ASSEMBLY INSTRUCTIONS AND PROCEDURES

- ◆ 1. THE PURPOSE OF THIS SECTION OF THE USER MANUAL IS TO ENSURE THAT THE MACHINE CAN BE INSTALLED EASILY AND CORRECTLY. PLEASE FOLLOW INSTRUCTIONS CAREFULLY AND ENTIRELY.
- ◆ 2. BECAUSE OF ITS LARGE SIZE AND WEIGHT, THE MACHINE SHOULD BE ASSEMBLED NEAR THE LOCATION WHERE IT WILL BE USED.
- ◆ 3. PLACE ALL PARTS OF THE MACHINE IN THE ASSEMBLY AREA AND REMOVE ALL PACKING MATERIAL. DO NOT DISCARD THE PACKAGING MATERIAL UNTIL THE ASSEMBLY IS COMPLETE.
- ◆ 4. ALL BOLTS MUST BE TIGHTENED DURING ASSEMBLY UNLESS OTHERWISE SPECIFIED, AND ALL BOLTS MUST BE TIGHTENED AFTER ASSEMBLY, IN ORDER FOR ASSEMBLY TO BE COMPLETE.
- ◆ 5. WHEN ASSEMBLING THE SB-PFRDC200S MAKE SURE THAT ALL PARTS ARE ASSEMBLED ACCORDING TO THE ASSEMBLY DIAGRAM.

WARRANTY INFORMATION

◆ WHAT IS COVERED SB

SB FITNESS WARRANTS TO THE ORIGINAL PURCHASER OF THIS MACHINE THAT THE FRAME OF THE PRODUCT SHALL BE FREE FROM DEFECT IN MATERIALS AND WORKMANSHIP AND UNDER WARRANTY FOR A PERIOD OF TWO YEARS FROM THE DATE OF PURCHASE. ALL OTHER PARTS AND COMPONENTS OF THE PRODUCT SHALL BE FREE FROM DEFECT IN MATERIAL AND WORKMANSHIP AND UNDER WARRANTY FOR A PERIOD OF ONE YEAR FROM THE DATE OF PURCHASE WHEN THE PRODUCT IS USED AS RECOMMENDED BY SB FITNESS UNDER NORMAL USES AND CONDITIONS. DURING THE WARRANTY PERIOD SB FITNESS WILL AT NO ADDITIONAL CHARGE TO YOU, REPAIR OR REPLACE (AT SB FITNESS' OPTION) THE FRAME OR ANY PART OF THE PRODUCT IF IT BECOMES DEFECTIVE, MALFUNCTIONS, OR OTHERWISE FAILS TO CONFORM WITH THIS LIMITED WARRANTY. ALL LABOR SHALL BE THE RESPONSIBILITY OF THE OWNER.

WARRANTY INFORMATION

◆ WHAT IS NOT COVERED

THIS LIMITED WARRANTY APPLIES ONLY FOR PRODUCT SOLD IN THE UNITED STATES UNDER THE SB FITNESS BRAND NAME. THIS WARRANTY DOES NOT COVER NORMAL WEAR AND TEAR ON ITEMS SUCH AS, BUT NOT LIMITED TO, TRANSPORTATION WHEELS, FOOT PEDALS, RUBBER GRIPS. PLASTIC END CAPS. SCRATCHED PARTS, BROKEN COVERS, COSMETIC DAMAGE, AND EXCLUDES PAINT & FINISH. WEAR ITEMS PERTAIN TO COMPONENTS THAT MIGHT NEED TO BE REPLACED DUE TO WEAR AND TEAR RESULTING FROM NORMAL USAGE. THIS WARRANTY IS VOID IF THE PRODUCT IS IMPROPERLY STORED, ASSEMBLED. ALTERED AND/OR MODIFIED IN ANY WAY. MISUSED. ABUSED, IS SUBJECT TO ACCIDENT, IS IMPROPERLY MAINTAINED, AND THIS WARRANTY DOES NOT COVER REPAIR FOR ANY NOISES SUCH AS: SQUEAKS. CLUNKS, THUMPS RESULTING FROM POOR OR LACK OF PREVENTIVE MAINTENANCE. THIS LIMITED WARRANTY DOES EXTENT TO ANY PRODUCT THAT IS DAMAGED OR RENDERED DEFECTIVE;(A) AS A RESULT OF ACCIDENT, MISUSE. OR ABUSE:(B) USE WITH THE PRODUCT OF ANY PART NOT MANUFACTURED OR SOLD BY SB FITNESS; (C) BY MODIFICATION OF THE PRODUCT; (D) BY NORMAL WEAR AND TEAR: (E) OPERATION USING INCORRECT POWER SUPPLIES; OR (F) AS A RESULT OF SERVICE BY ANYONE OTHER THAN SB FITNESS. OR AN AUTHORIZED SB FITNESS SERVICE PROVIDER.

ASSUMPTION OF RISK



WARNING



THIS PRODUCT HAS BEEN MANUFACTURED WITH SAFETY IN MIND. WARRANTY APPLIES ONLY WHEN USED AS INSTRUCTED. FAILURE TO COMPLY WITH THE WARNINGS AND PRECAUTIONS DESCRIBED IN THIS DOCUMENT MAY CAUSE PERSONAL INJURY AND RESULT IN WARRANTY BEING VOIDED. PLEASE NOTE THAT SB FITNESS ASSUMES NO RESPONSIBILITY FOR ANY ACCIDENTS RESULTING FROM USE.

CALIFORNIA PROPOSITION



65 WARNING



WARNING: THIS PRODUCT CAN EXPOSE YOU TO CHEMICALS INCLUDING ARSENIC, WHICH IS KNOWN TO THE STATE OF CALIFORNIA TO CAUSE CANCER. FOR MORE INFORMATION, GO TO WWW.P65WARNINGS.CA.GOV.XN--IVG