

SB-BTCC200S

SB Fitness Equipment

BICEP / TRICEP COMBO MACHINE



SB

Owners Manual
and Assembly Guide

PARTS DIAGRAM EXPLODED VIEW

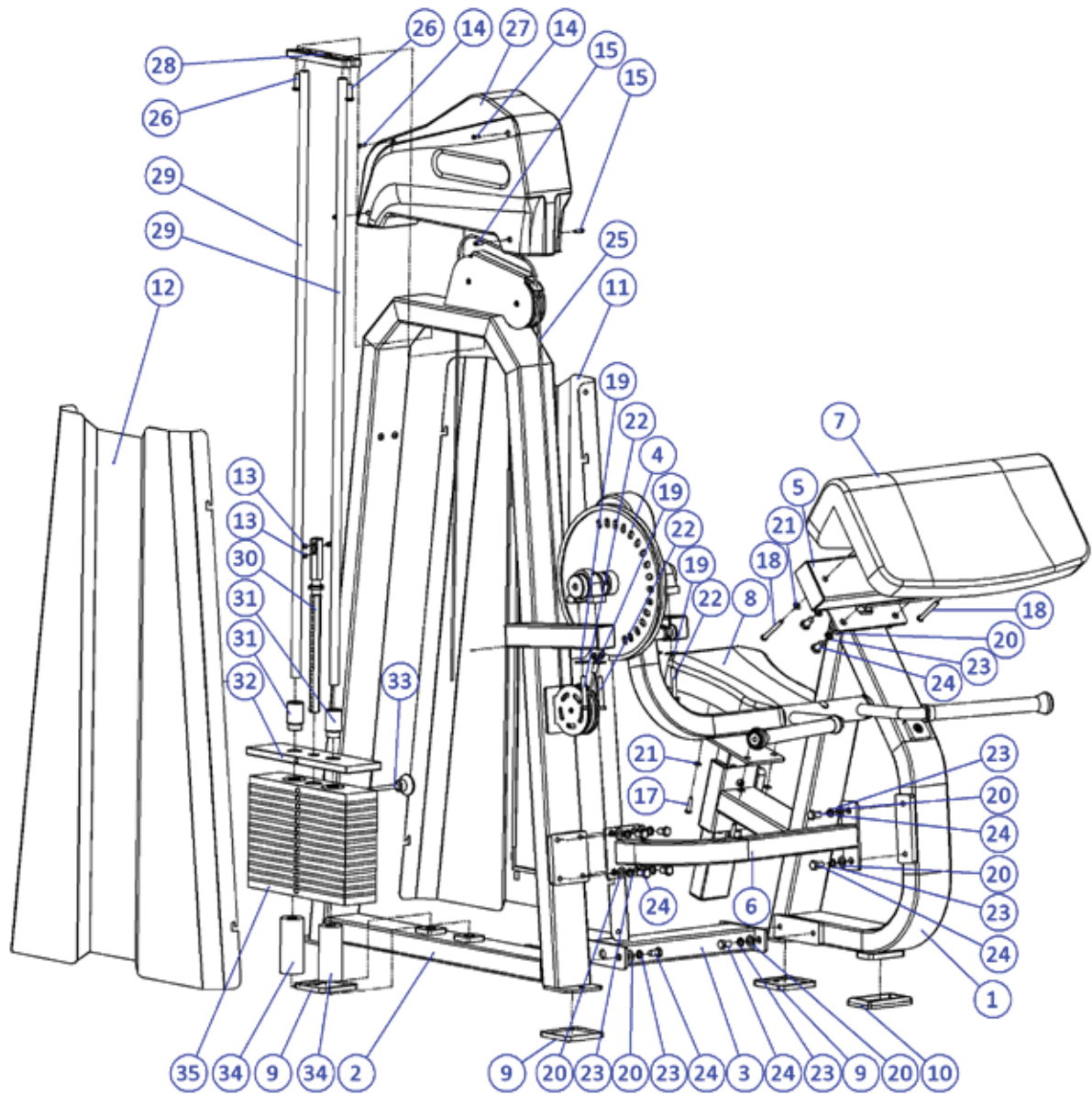

PARTS LIST AND PART NUMBERS

SERIAL NUMBER	PART NUMBER	SPAR PART NAME	STANDARD SIZES	AMOUNT (PIECE)
1	100	MAIN FRAME ASSEMBLY		1
2	200	WEIGHT STACK FRAME ASSEMBLY		1
3	300	COMBINATION OF CONNECTING PIPES		1
4	400	HANDLE COMBINATION OF MOVABLE ARM PLATE.		1
5	500	ELBOW PAD MOUNTING TUBE ASSEMBLY.		1
6	1300	SUPPORTING FRAME ATTACHMENT		1
7	1707	ELBOW CUSHION OF PRIEST'S CHAIR.		1
8	---	UNIVERSAL SMALL CUSHION.	340*268	1
9	W7009	BOTTOM FOOT PAD	3*100*90	3
10	W7010	RUBBER FOOT PADS	50*100	1
11	B7041	INNER GUARD PLATE	L1210	1
12	B7042	OUTER CASING	L1210	1
13	S5120-02	TOP THREAD M8	M8*10	3
14			M5*10	2
15	S5124-01	HEXAGON SOCKET HEAD SCREW.	M6*16	4
16	S5110-01	HEXAGON SOCKET HEAD SCREW.	M8*16	8
17	S5110-04	HEXAGON SOCKET HEAD SCREW.	M8*30	4
18	S5110-07	HEXAGON SOCKET HEAD SCREW.	M8*70	2
19	S5302	FLAT GASKET	T2.5*D10.5*D30	4
20	S5301	FLAT GASKET	T1.5*D13*D24	14
21	S5304	FLAT GASKET	T1*D8*D16	6
22	S5107-05	OUTER HEXAGON SCREW.	M10*65	4
23	S5702	SPRING WASHER	D12.5*D18*T2.5	14
24	S5108-03	OUTER HEXAGON SCREW.	M12*20	14
25	W5045	WIREROPE	Φ6	2.3
26	S5103-02	HEXAGON SOCKET HEAD SCREW.	M10*30	2
27	W7020	TOP CAP SHELL OF DOOR.	FRONT AND BACK PAIR.	1
28	W7005	GUIDE ROD FIXING PLATE	GENERAL SPECIFICATIONS	1
29	G7008	GUIDE BAR	ASSEMBLE ACCESSORIES-20 STAINLESS STEEL PIPE LENGTH ASSEMBLY FITTINGS- 20 STAINLESS STEEL PIPE LENGTH 1331 .	2
30	C7009-13	CENTER BAR OF COUNTERWEIGHT PLATE.	ASSEMBLY PARTS -13 HOLES.	1
31	W7031	TOP SHEET BUFFER COLUMN ON COUNTERWEIGHT SHEET.	-----	2
32	W7025-01	TOP SHEET ON COUNTERWEIGHT SHEET.	T15 HOLE SPACING 127.	1
33	W7026	WEIGHT PLATE ADJUSTING PIN (BLUE).	Φ8*115	1
34	W7027	LONG CUSHION UNDER COUNTERWEIGHT PLATE.	D21*D51*120	2
35	W7023	COUNTERWEIGHT SHEET	90*320*T24	14

INSTALLATION DETAILS

STEP 1: ATTACH THE MAIN FRAME ASSEMBLY(1) TO THE WEIGHT STACK FRAME ASSEMBLY(2). INSTALL THE RUBBER FOOT PADS(10) AT THIS TIME(OPTIONAL). INSTALL THE SUPPORTING FRAME ATTACHMENT(6) TO CONNECT THE MAIN FRAME ASSEMBLY AND THE WEIGHT STACK ASSEMBLY

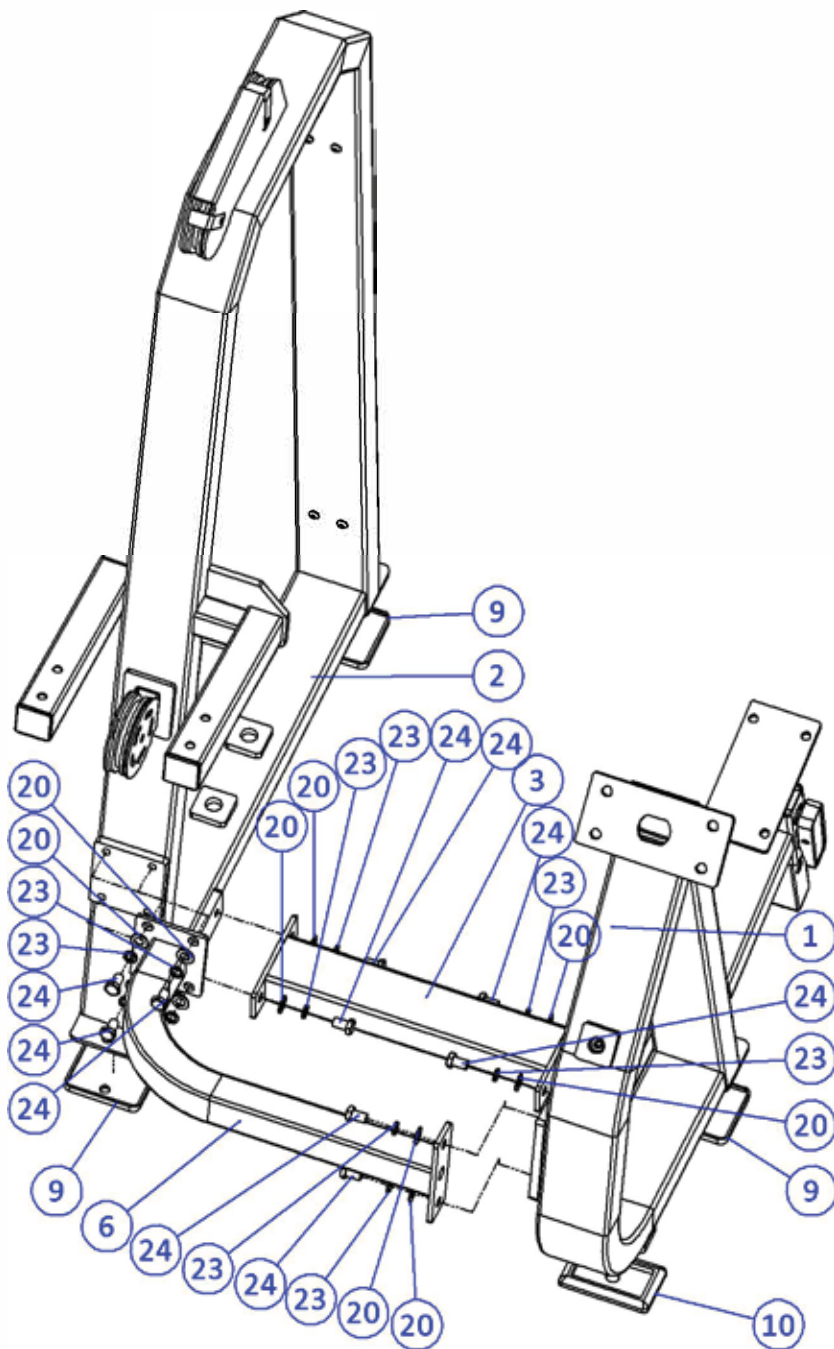

INSTALLATION DETAILS

STEP 2:

- 1.) INSTALL GUIDERODS(7) INTO HOLES LOCATED INSIDE BOTTOM OF WEIGHT STACK FRAME.
- 2.) SLIDE 2 - #32 SPACERS ON FROM TOP OF GUIDE RODS TO HAVE 2 ON EACH GUIDE ROD AT THE BOTTOM.
- 3.) INSTALL WEIGHT PLATES(29). SMALLEST WEIGHT PLATE IS LAST AS THIS IS THE TOP PLATE.
- 4.) INSTALL #27 ON TO GUIDE ROD AND INTO TOP PLATE.
- 5.) INSTALL SELECTOR ROD(28) INTO WEIGHT STACK CENTER HOLE.
- 6.) SECURE TOP OF GUIDE RODS TO WEIGHT STACK FRAME USING #9 PLATE AND #17 BOLTS.
- 7.) PLACE SELECTOR PIN(30) INTO WEIGHT STACK.

**** REFER PAGE 5 FOR IMAGE AND REFER TO PAGE 8 & 9 FOR FURTHER ASSISTANCE****

INSTALLATION DETAILS

STEP 2:

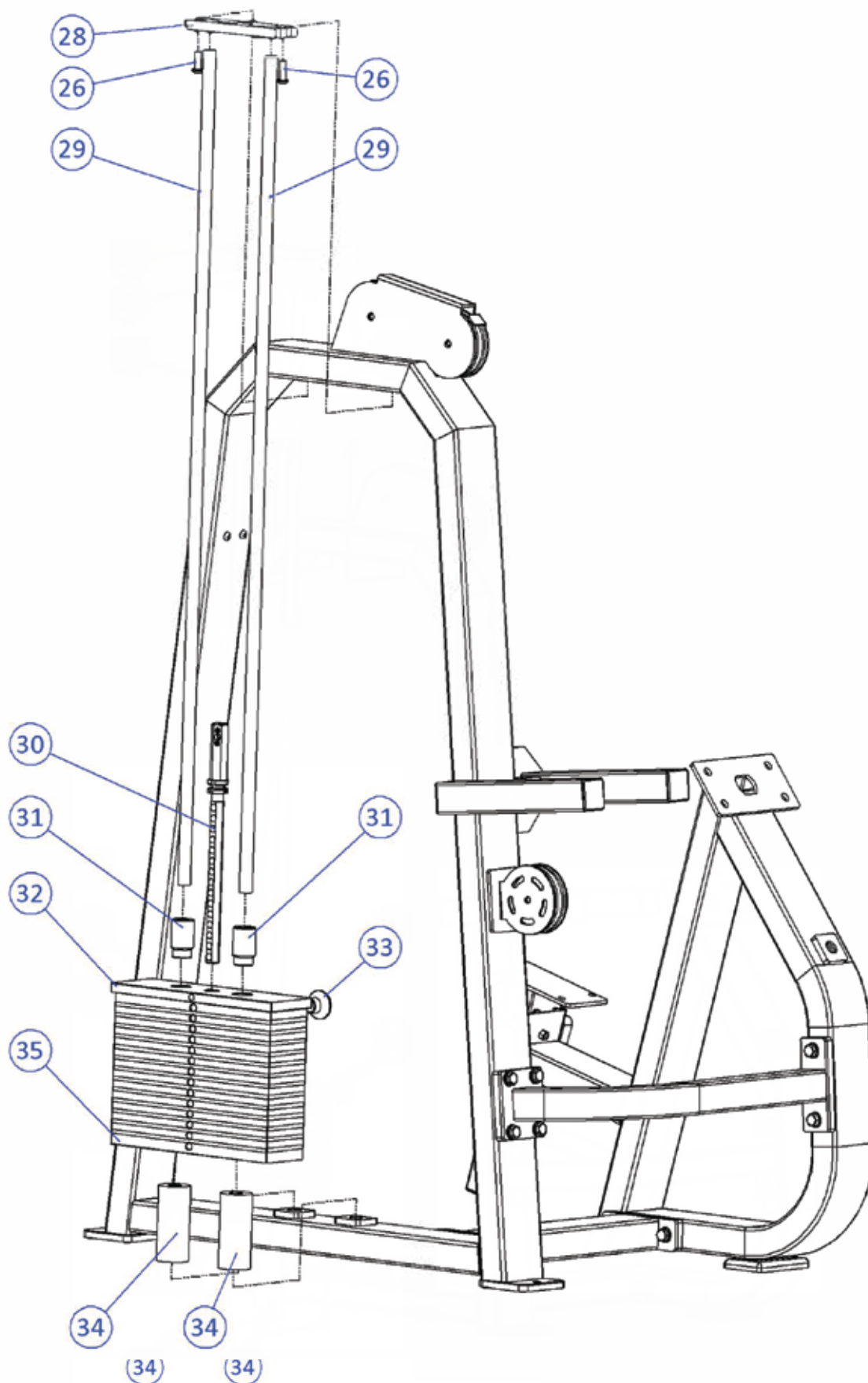

INSTALLATION DETAILS

STEP 3: INSTALL ARM PAD TO MOUNTING TUBE ASSEMBLY, BOOM HANDLE ASSEMBLY. AFTER INSTALLING THE CAM(4) AND ADJUSTABLE BICEP/TRICEP GRIP HANDLES, INSTALL WEIGHT PLATE CABLE STARTING AT MOUNTING LOCATION ON THE CAM(4).

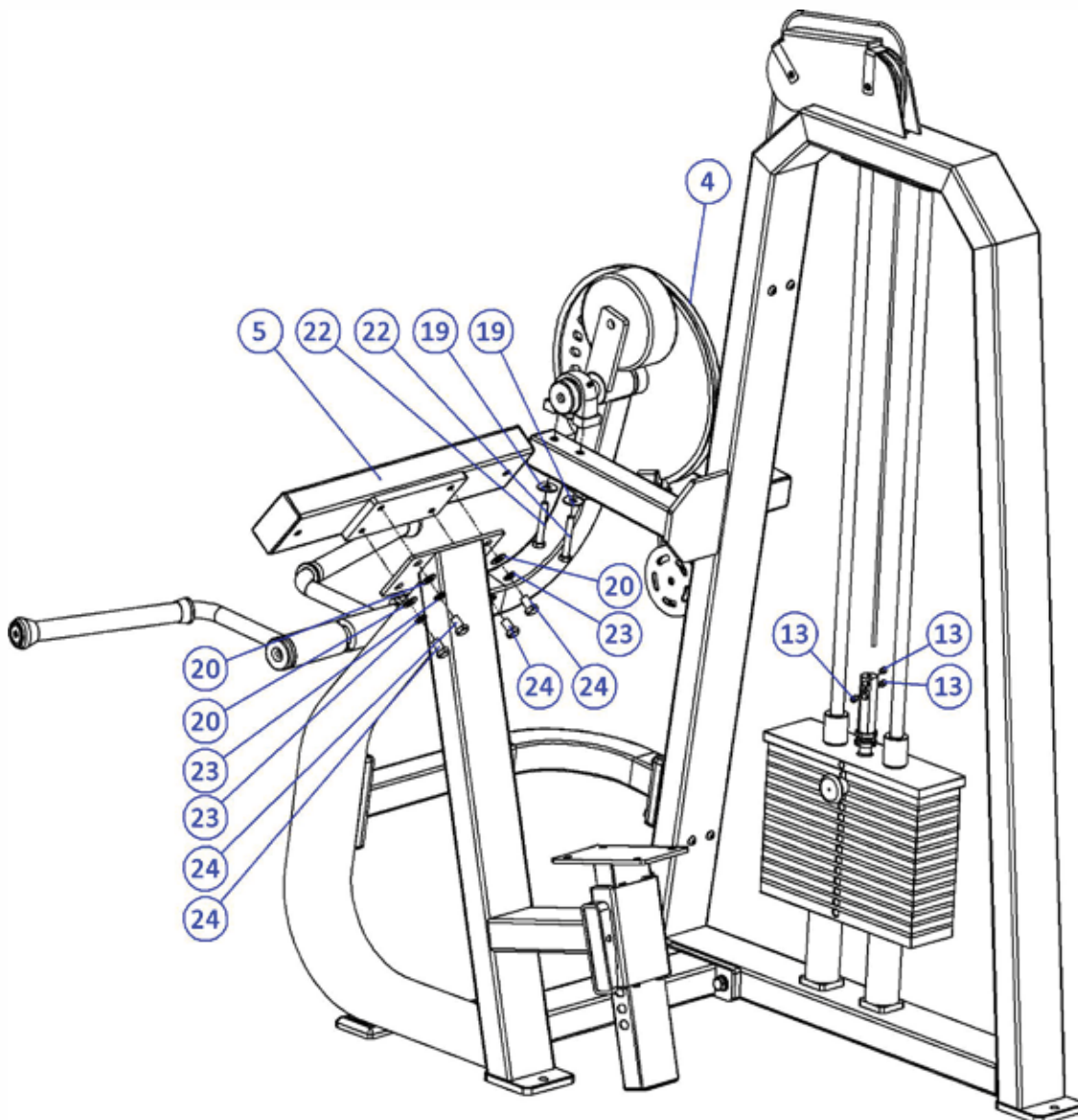

INSTALLATION DETAILS

STEP 4: INSTALL LEFT(12) AND RIGHT(11) WEIGHT FRAME GUARDS AND THE WEIGHT STACK FRAM TOP COVER.

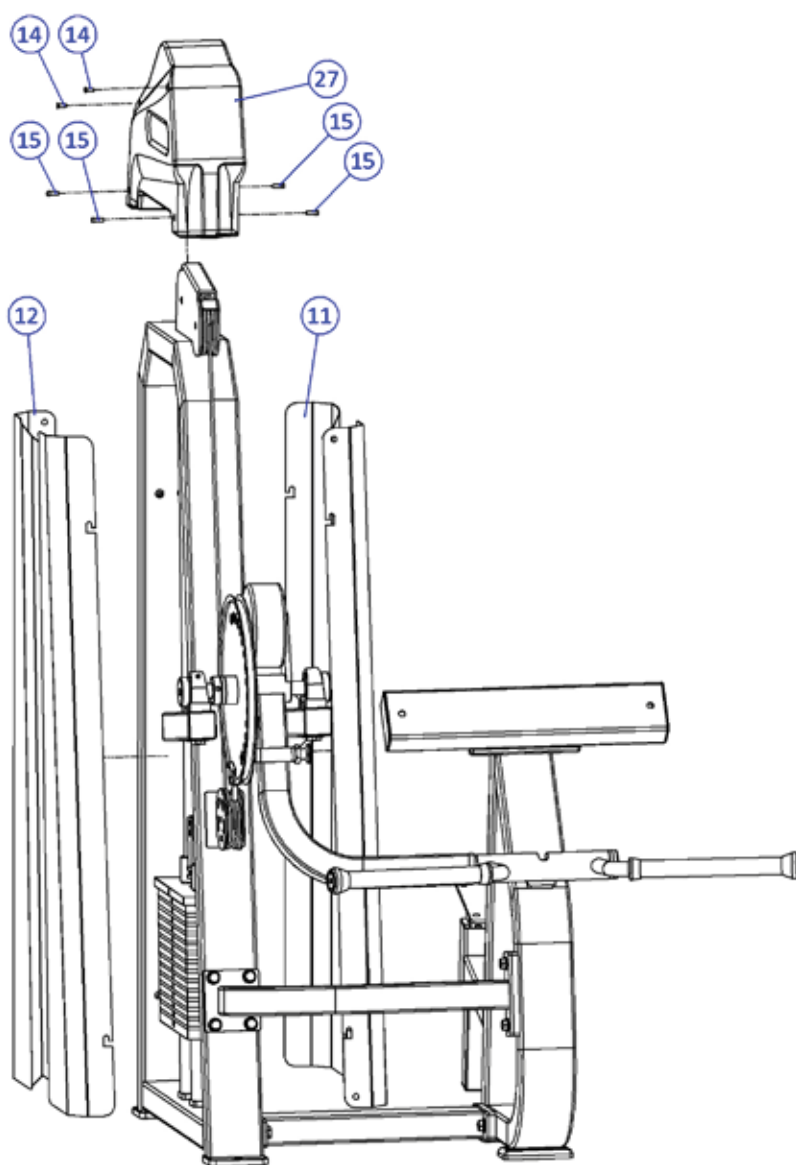

INSTALLATION DETAILS

STEP 5: INSTALL ELBOW PADS AND SEAT CUSHIONS.

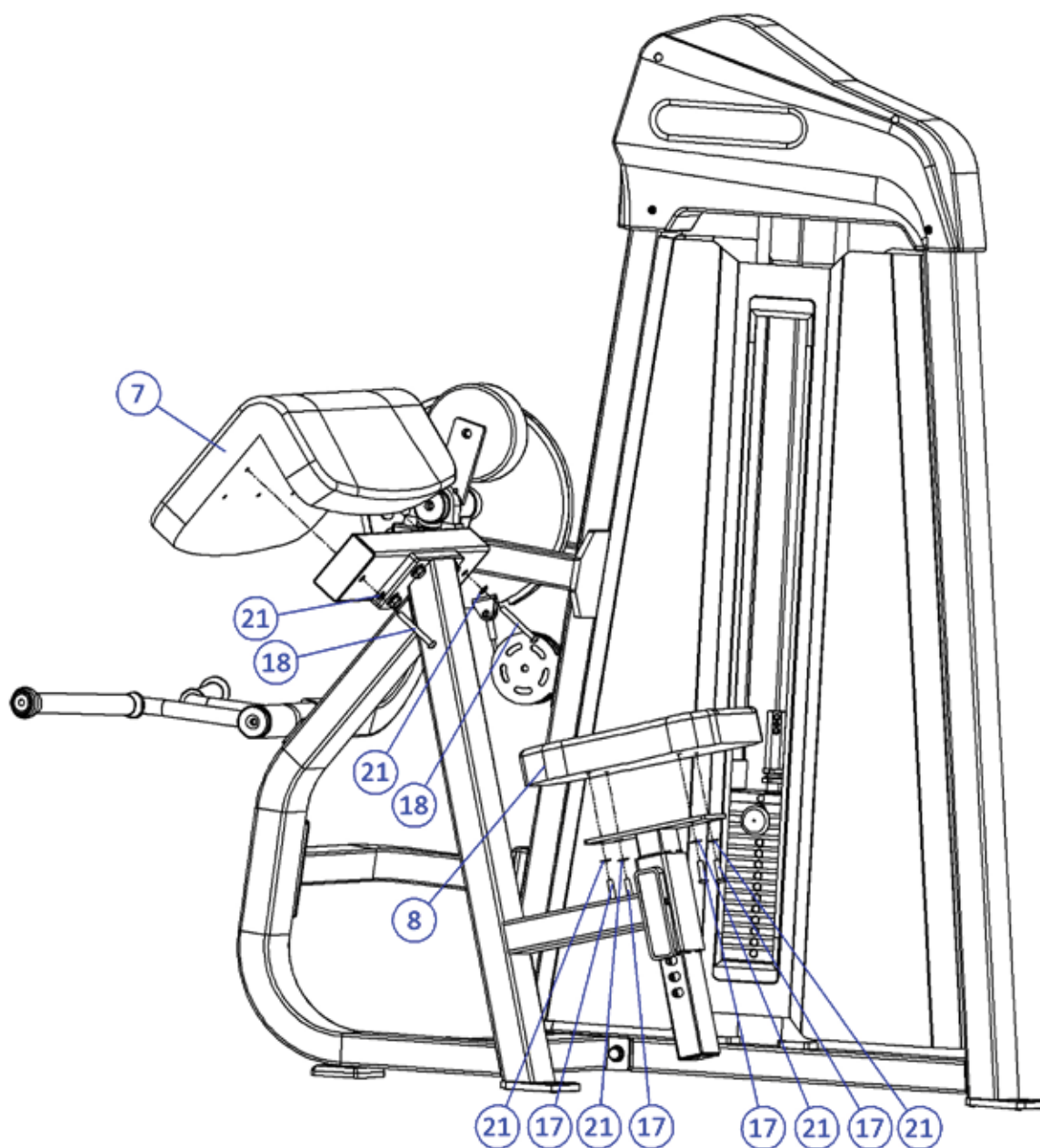

APPENDIX 1: ORIENTATION DISTINGUISHING METHOD OF COUNTERWEIGHT SHEET

THE SIDE WITH RUBBER COLLAR IS UPWARD



THE SIDE WITH THE ADJUSTING JACK FACES THE TRAINER

APPENDIX 1: INSTALLATION SEQUENCE OF COUNTERWEIGHT

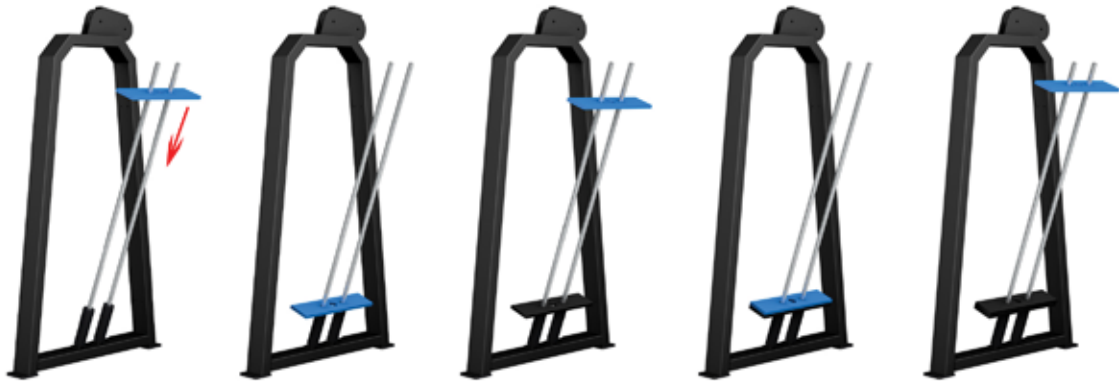

1. INSERT THE FIRST COUNTERWEIGHT PIECE FROM TOP TO BOTTOM.

2. EACH OF THE NEXT STEPS IS THE SAME AS THE FIRST.

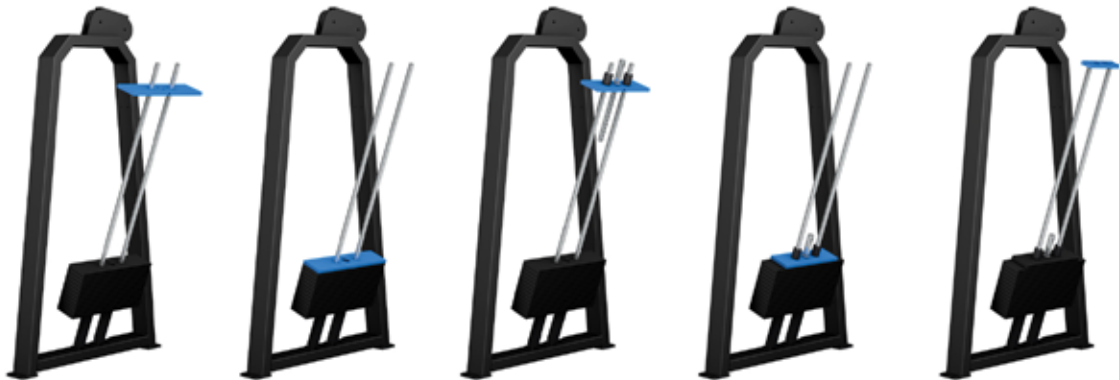

3. THE NUMBER OF INSTRUMENTS WITH SINGLE PIECE WEIGHT OF 10LB AND COUNTERWEIGHT OF 200LB IS $19 + 1$ (HEAD PIECE).

4. AFTER INSTALLING THE HEAD PIECE, PUT ON THE PLASTIC FIXING PLATE.



5. FIRST MOVE THE PLASTIC FIXING PLATE TO THE POSITION SHOWN IN THE FIGURE, AND THEN TIGHTEN IT WITH SCREWS TO COMPLETE THE WHOLE INSTALLATION PROCESS OF COUNTERWEIGHT PIECE.

INSTALL WEIGHT STACK CABLE

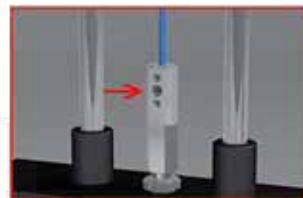
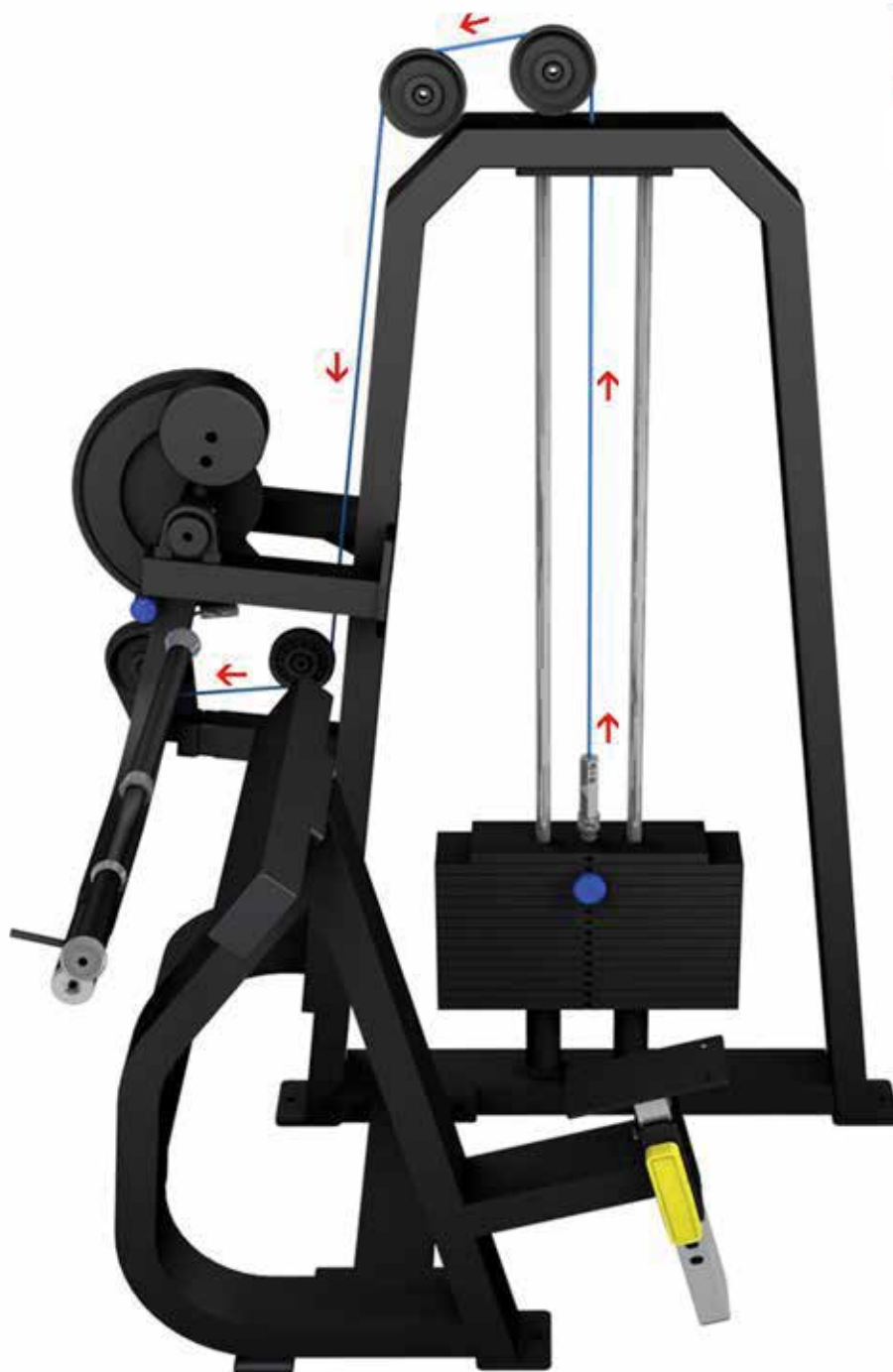

WARNING: THE SCREWS AT EACH JOINT OF THE WEIGHT STACK CABLE MUST BE FULLY TIGHTENED

PRODUCT DESCRIPTION, SPECS, & FEATURES



SB FITNESS EQUIPMENT / SB-BTC200S

PRODUCT NAME: : BICEP/TRICEP COMBO MACHINE

WEIGHT STACK: 200LB

PRODUCT FEATURES: BICEP CURLS AND TRICEP EXTENSIONS COMBO IN ONE MACHINE

PRODUCT DIMENSIONS: 45.5" L X 43" W X 64.5 H

MUSCLES WORKED: BICEPS, TRICEPS, BRACHIORDIALIS AND FOREARMS.

FOR YOUR SAFETY

- ◆ 1. CONSULT YOUR PHYSICIAN OR HEALTH CARE PROVIDER BEFORE USING YOUR MACHINE AND/OR EXERCISE EQUIPMENT.
- ◆ 2. IF YOU HAVE A PHYSICAL DISABILITY OR AN ATHLETIC DISABILITY, IT IS REQUIRED THAT YOU CONSULT YOUR PHYSICIAN OR HEALTH CARE PROVIDER BEFORE PROCEEDING WITH ANY EXERCISE PROGRAM.
- ◆ 3. BEFORE USING THIS PRODUCT, PLEASE READ THIS MANUAL CAREFULLY. SB FITNESS EQUIPMENT IS NOT RESPONSIBLE FOR ANY PERSONAL INJURY OR DAMAGE CAUSED BY USING THIS PRODUCT UNDER ANY CIRCUMSTANCES OR NEGLIGENCE CAUSED BY THE USER.

ASSEMBLY INSTRUCTIONS AND PROCEDURES

- ◆ 1. THE PURPOSE OF THIS SECTION OF THE USER MANUAL IS TO ENSURE THAT THE MACHINE CAN BE INSTALLED EASILY AND CORRECTLY. PLEASE FOLLOW INSTRUCTIONS CAREFULLY AND ENTIRELY.
- ◆ 2. BECAUSE OF ITS LARGE SIZE AND WEIGHT, THE MACHINE SHOULD BE ASSEMBLED NEAR THE LOCATION WHERE IT WILL BE USED.
- ◆ 3. PLACE ALL PARTS OF THE MACHINE IN THE ASSEMBLY AREA AND REMOVE ALL PACKING MATERIAL. DO NOT DISCARD THE PACKAGING MATERIAL UNTIL THE ASSEMBLY IS COMPLETE.
- ◆ 4. ALL BOLTS MUST BE TIGHTENED DURING ASSEMBLY UNLESS OTHERWISE SPECIFIED, AND ALL BOLTS MUST BE TIGHTENED AFTER ASSEMBLY, IN ORDER FOR ASSEMBLY TO BE COMPLETE.
- ◆ 5. WHEN ASSEMBLING THE SB-BTC200S MAKE SURE THAT ALL PARTS ARE ASSEMBLED ACCORDING TO THE ASSEMBLY DIAGRAM.

WARRANTY INFORMATION

◆ WHAT IS COVERED SB

SB FITNESS WARRANTS TO THE ORIGINAL PURCHASER OF THIS MACHINE THAT THE FRAME OF THE PRODUCT SHALL BE FREE FROM DEFECT IN MATERIALS AND WORK MANSHIP AND UNDER WARRANTY FOR A PERIOD OF TWO YEARS FROM THE DATE OF PURCHASE. ALL OTHER PARTS AND COMPONENTS OF THE PRODUCT SHALL BE FREE FROM DEFECT IN MATERIAL AND WORKMANSHIP AND UNDER WARRANTY FOR A PERIOD OF ONE YEAR FROM THE DATE OF PURCHASE WHEN THE PRODUCT IS USED AS RECOMMENDED BY SB FITNESS UNDER NORMAL USES AND CONDITIONS. DURING THE WARRANTY PERIOD SB FITNESS WILL AT NO ADDITIONAL CHARGE TO YOU, REPAIR OR REPLACE (AT SB FITNESS' OPTION) THE FRAME OR ANY PART OF THE PRODUCT IF IT BECOMES DEFECTIVE, MALFUNCTIONS, OR OTHERWISE FAILS TO CONFORM WITH THIS LIMITED WARRANTY. ALL LABOR SHALL BE THE RESPONSIBILITY OF THE OWNER.

WARRANTY INFORMATION

◆ WHAT IS NOT COVERED

THIS LIMITED WARRANTY APPLIES ONLY FOR PRODUCT SOLD IN THE UNITED STATES UNDER THE SB FITNESS BRAND NAME. THIS WARRANTY DOES NOT COVER NORMAL WEAR AND TEAR ON ITEMS SUCH AS, BUT NOT LIMITED TO, TRANSPORTATION WHEELS, FOOT PEDALS, RUBBER GRIPS. PLASTIC END CAPS. SCRATCHED PARTS, BROKEN COVERS, COSMETIC DAMAGE, AND EXCLUDES PAINT & FINISH. WEAR ITEMS PERTAIN TO COMPONENTS THAT MIGHT NEED TO BE REPLACED DUE TO WEAR AND TEAR RESULTING FROM NORMAL USAGE. THIS WARRANTY IS VOID IF THE PRODUCT IS IMPROPERLY STORED, ASSEMBLED. ALTERED AND/OR MODIFIED IN ANY WAY. MISUSED. ABUSED, IS SUBJECT TO ACCIDENT, IS IMPROPERLY MAINTAINED, AND THIS WARRANTY DOES NOT COVER REPAIR FOR ANY NOISES SUCH AS: SQUEAKS. CLUNKS, THUMPS RESULTING FROM POOR OR LACK OF PREVENTIVE MAINTENANCE. THIS LIMITED WARRANTY DOES NOT EXTEND TO ANY PRODUCT THAT IS DAMAGED OR RENDERED DEFECTIVE; (A) AS A RESULT OF ACCIDENT, MISUSE. OR ABUSE; (B) USE WITH THE PRODUCT OF ANY PART NOT MANUFACTURED OR SOLD BY SB FITNESS; (C) BY MODIFICATION OF THE PRODUCT; (D) BY NORMAL WEAR AND TEAR; (E) OPERATION USING INCORRECT POWER SUPPLIES; OR (F) AS A RESULT OF SERVICE BY ANYONE OTHER THAN SB FITNESS. OR AN AUTHORIZED SB FITNESS SERVICE PROVIDER.

ASSUMPTION OF RISK



THIS PRODUCT HAS BEEN MANUFACTURED WITH SAFETY IN MIND. WARRANTY APPLIES ONLY WHEN USED AS INSTRUCTED. FAILURE TO COMPLY WITH THE WARNINGS AND PRECAUTIONS DESCRIBED IN THIS DOCUMENT MAY CAUSE PERSONAL INJURY AND RESULT IN WARRANTY BEING VOIDED. PLEASE NOTE THAT SB FITNESS ASSUMES NO RESPONSIBILITY FOR ANY ACCIDENTS RESULTING FROM USE.

CALIFORNIA PROPOSITION



WARNING: THIS PRODUCT CAN EXPOSE YOU TO CHEMICALS INCLUDING ARSENIC, WHICH IS KNOWN TO THE STATE OF CALIFORNIA TO CAUSE CANCER. FOR MORE INFORMATION, GO TO WWW.P65WARNINGS.CA.GOV.XN--IVG