



DC25 Distribution Box

Dual Battery System & Solar Charger



OWNERS MANUAL

Index

Introduction	2
Safety Information	2
Features	3
Wiring Diagram	4
Preparing for Installation	4
Connecting Auxiliary battery	5
Connecting remote temperature sensor	6
Selecting Battery Type	7
Connecting Solar Panels	8
Connecting External Battery Chargers	8
Ignition Over-ride	8
System Operation	9
Remote Monitor	10
Remote Monitor Status Messages	12
Specifications	13
Warranty	15

Introduction

The **National Luna DC25 Distribution Box** is ideally suited to fixed installations such as trailers, caravans and campers where the auxiliary batteries are separated from the charge system.

The DC25 Distribution Box features a high-performance 25A DC-DC charge system that offers charging from the vehicle alternator as well as from Solar panels. Multiple outputs offer USB charging and fused DC sockets for connecting 12V devices.

The DC25 Distribution Box supports 12V lead-acid (wet, calcium, Gel, AGM) as well as lithium batteries.

The introduction of two dual-port USB modules with fast charge allows several smart devices such as smart-phones, tablets, GPS, cameras and other USB-devices to be powered up to 18W on each port.

Heavy-duty connectors can be used for connecting a variety of accessories from inverters (600W max) to fridges and other small appliances. These connectors can also be used with external battery chargers as an alternative to the built-in dedicated charge port.

The primary charge input supports 12V and 24V vehicle systems and will provide up to 25A of current to the auxiliary battery using an optimized 6-stage charge algorithm.

A built-in 25A MPPT solar regulator circuit supports solar panels up to 42V and provides up to 25A (375W) charge current to the battery.

Supported battery types (*set to AGM by default*) :

- Lead-acid (Calcium, Flooded, AGM, Gel, VRLA)
- Lithium-ion, LiFePO4

Temperature Compensation & battery protection :

- The battery charge profile takes into account battery temperature for safe charging when the remote temperature sensor is connected.

SAFETY INFORMATION :

- Before installation, read the instructions carefully.
- The DC25 Distribution Box is used for charging 12V lead-acid and Lithium batteries only.
- Do not use for any purpose other than indicated in this manual.
- Do not attempt to charge a non-rechargeable or battery other than 12V.
- Never attempt to charge a damaged or leaking battery.
- Avoid open flames in the vicinity of the battery.
- Do not alter or modify the DC25 Distribution Box under any circumstances.
- Unauthorized disassembly, repairs or modifications will void any warranty.
- Attempts to use the DC25 Distribution Box for purposes other than indicated in this manual will void the warranty.
- Ensure all connections are secure and cables are installed in a safe manner.
- Use the correct cabling size and fuses in accordance with the installation instructions.
- Install the supplied in-line fuses as indicated in the installation instructions.
- Ensure the DC25 Distribution Box is secured in mobile applications.

Features

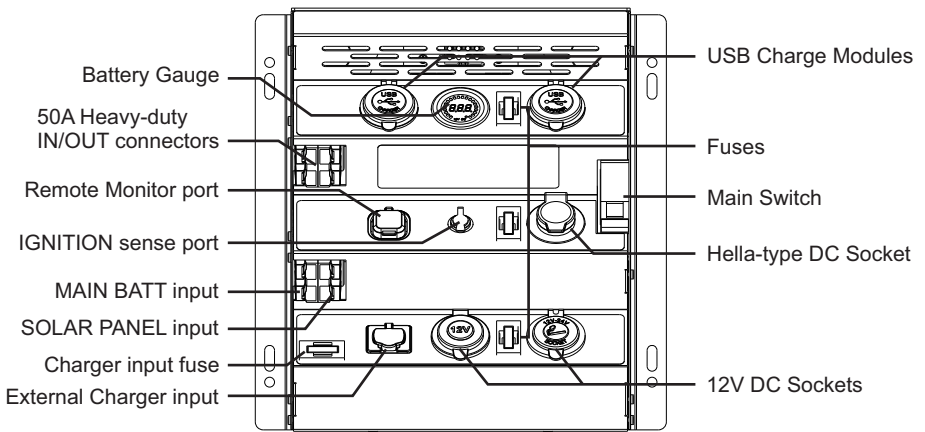
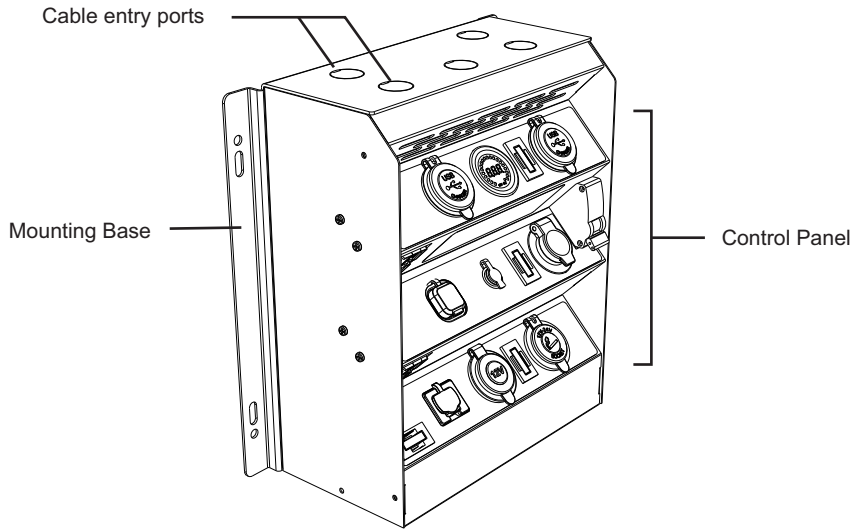

Wiring diagram - Typical Installation

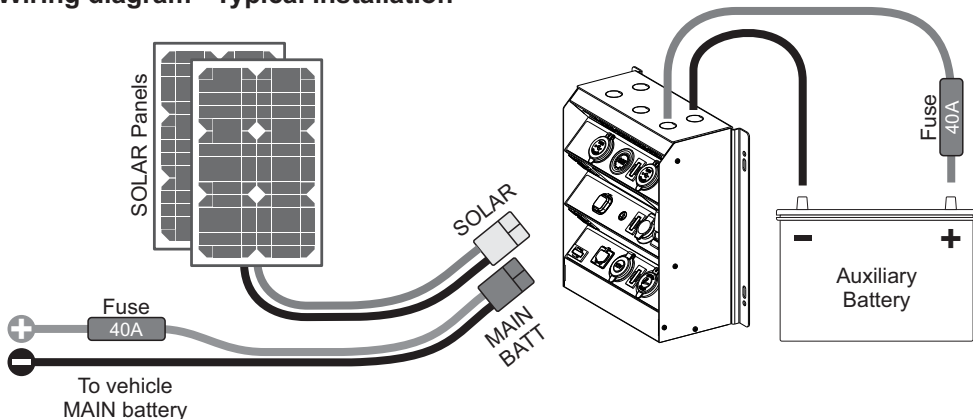

Preparing for Installation

The DC25 Distribution Box should be mounted securely on a flat surface using the mounting frame. (Fig 1).

Locate the DC25 Distribution Box such that the cables are not restricted or under strain.

Allow a 50mm gap along the bottom of the DC25 Distribution Box for ventilation.

Open the cable entry holes and attach grommets before mounting the DC25 Distribution Box.

Use 16mm² cables for the input from the vehicle main battery and cables to the auxiliary battery.

Install a 40A in-line fuse close to the main battery on the positive cable (Fig 2).

Install a second 40A fuse close to the auxiliary battery on the positive cable.

Make sure all connections are secure and terminated correctly with appropriate tools.

The input cables must be terminated with a RED 50A coupler matching the input on the DC Distribution Box marked "MAIN BATT".

If solar panels are used, they can be connected to the input marked "SOLAR PANEL" and must have a maximum voltage below 42V.

Fig 1

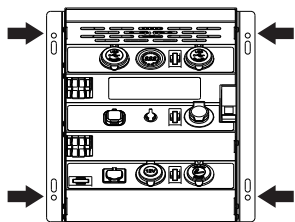

Secure the DC25 Distribution Box onto a flat surface using the holes in the mounting frame

Fig 2

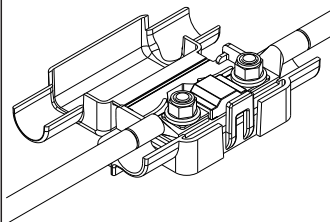

Install the fuse on the positive cable close to the main battery. Ensure terminals are crimped securely.

Connecting Auxiliary battery cables

Cables to the auxiliary must be connected internally. It is necessary to remove the main cover for this.

With the cover open, the remote temperature probe can be connected and battery type selected.

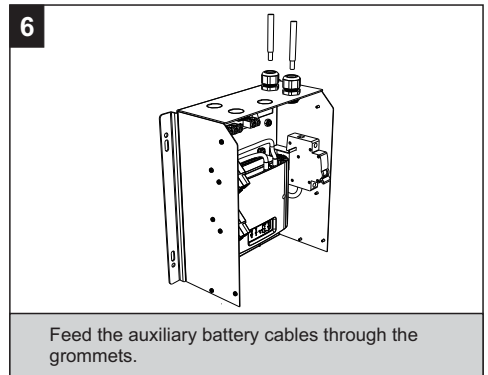
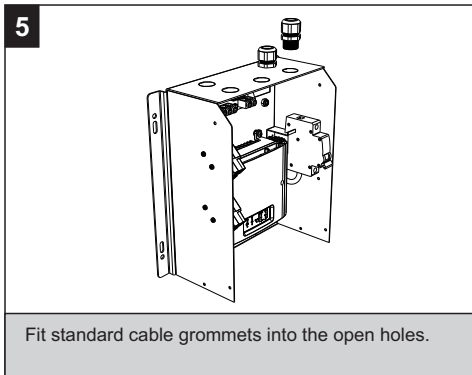
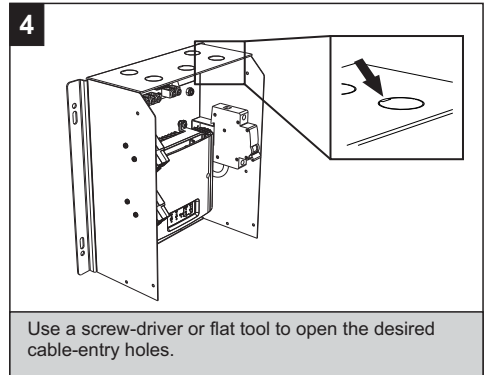
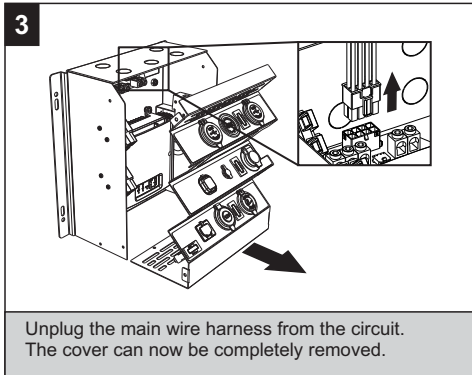
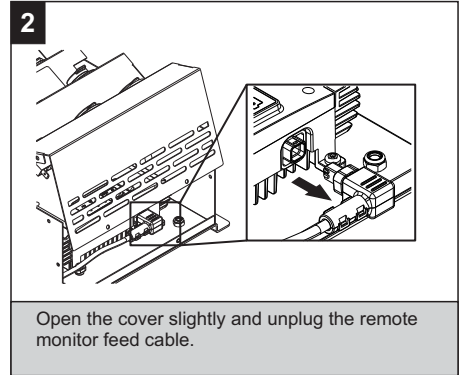
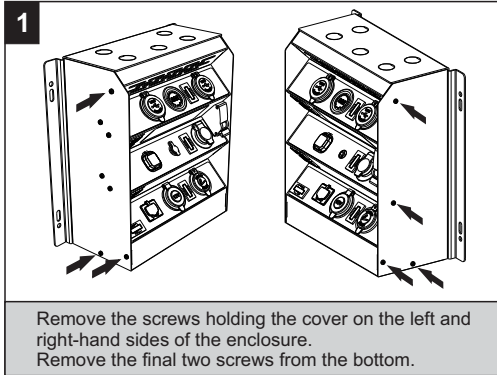

Connecting battery cables ... cont.

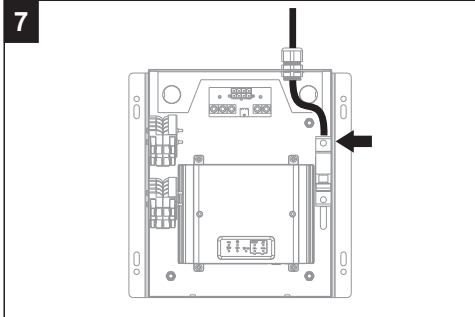

Feed the positive battery cable through the grommet and connect it to the top terminal of the main switch.

Make sure the terminal screw is tight.

Tighten the cable grommets when done.

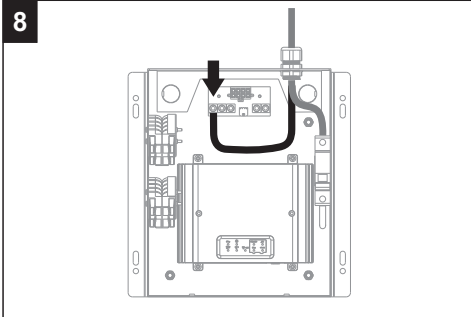

Feed the negative cable to the terminal indicated. Loosen the screw and insert the battery cable on top of the existing cable.

Make sure the terminal is re-tightened.

Tighten the cable grommets when done.

Tip :

Feed the remote temperature sensor wire together with the positive or negative battery cables.

Connecting remote temperature sensor

The remote temperature sensor provides feedback to the system about the battery temperature. This is used to ensure safe and full charge under a variety of ambient conditions.

The sensor should be placed onto the auxiliary battery for best results.

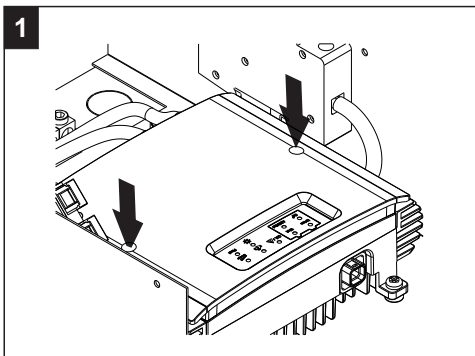

Remove the cover of the internal DC-DC system by loosening two screws on top.

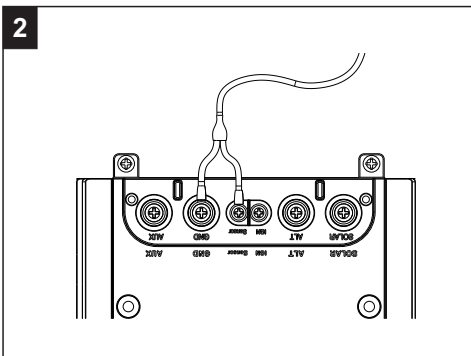

Connect the smaller ring of the sensor to the terminal marked "Sense".
Connect the larger ring to the GND terminal.

Changing battery type

With the cover still removed, the auxiliary battery type can be selected.

Ensure the main breaker switch is in the OFF position then connect a 12V power source to the MAIN BATTERY or SOLAR inputs. The system will indicate the current battery type.

Press the "Battery" button to select the desired battery type.

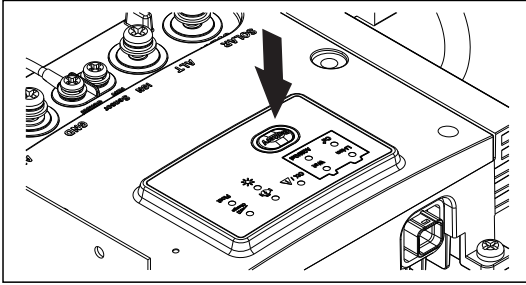

Battery Types	
Li-ion	Used for automotive Lithium-ion or LiFePO4 batteries.
Wet	Used for regular automotive starting and flooded high-cycle batteries.
Ca+	Used for flooded deep-cycle, calcium and maintenance-free batteries.
AGM / Gel	Used for all types of AGM and Gel batteries.

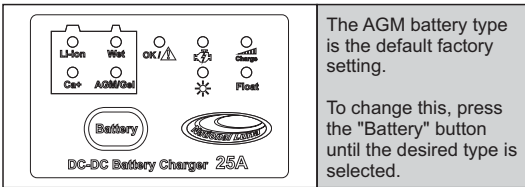

Reassembly

Once the preferred battery type is selected, disconnect the power source.

- Replace the cover of the DC-DC system.
- Re-connect the wire harness and any other wires removed earlier.
- Re-connect the remote monitor plug and close the cover.
- Re-install and tighten the screws that were removed earlier.
- The auxiliary battery can now be connected.

Connecting Solar Panels

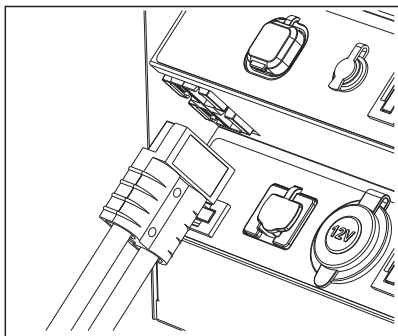

The Distribution Box supports the direct connection of solar panels up to 42V through the heavy-duty connector marked "SOLAR PANEL".

Note that if the solar panels have internal regulators, connect them to one of the AUXILIARY IN/OUT connectors instead.

This will bypass the Power Pack solar MPPT system.

Connecting external Battery Chargers

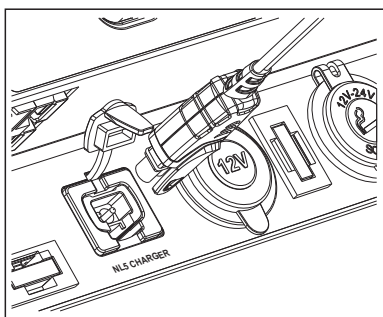

The Distribution Box has a charge port specifically for use with National Luna Intelligent Battery Chargers.

Insert the charger quick-connector into the charge port labeled "NL5 CHARGER" until it clicks securely.

In order to connect other brands of chargers to this input, a quick-connector cable is available separately. This port can support up to 10A charge current.

Other charger brands can be connected to one of the grey heavy-duty AUXILIARY IN/OUT connectors. Charge currents exceeding 10A can then be connected.

Ignition over-ride (optional accessory)

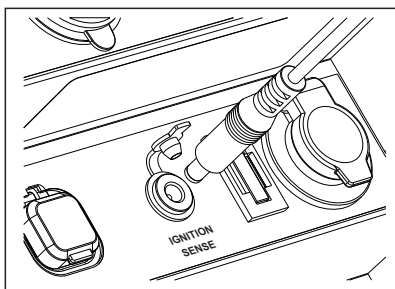

The IGNITION SENSE port increases support for vehicles where the charge voltage drops very low or is very erratic. This may be the case in some vehicles with "Smart Alternators".

Plug the small end of the over-ride cable (optional) into the IGNITION SENSE port.

Plug the larger end into a socket that provides a positive voltage only when the ignition of the vehicle is ON.

CAUTION

Connecting the IGNITION over-ride to a permanent 12V source may result in excessive discharge of the MAIN battery.

Only use the IGNITION SENSE feature if the vehicle alternator voltage is below 13.2V under normal conditions.

System operation

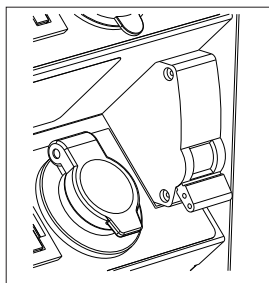

Main Switch

In order to charge or supply power to accessories connected to any of the plugs & sockets, the main switch on the Distribution Box must be in the ON position.

When not in use then it is best to turn the switch OFF. This will isolate the auxiliary battery from all loads.

Charge to the auxiliary battery will start once voltage on the MAIN BATT input exceeds 13.2V. It will stop charge once voltage drops below 12.6V after a short delay.

If the IGNITION SENSE input is used, charge will begin with input voltage above 12.0V and stop when voltage drops below 11.5V.

If solar panels are connected and exposed to sunlight, the Distribution Box will seek the maximum power possible from the panels under the present conditions. Voltage from the panel must be between 9V and 42V.

If both MAIN BATT and SOLAR are connected simultaneously. Priority will be given to the MAIN BATT source and will switch to the SOLAR source automatically when voltage on the MAIN BATT input drops below 12.6V (11.5V if IGNITION SENSE is used).



Top group
(5A)

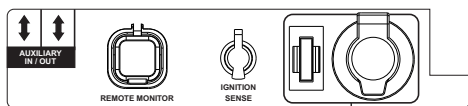

Middle group
(15A)

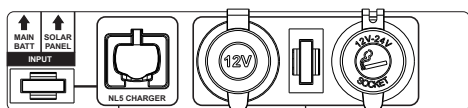

Charger fuse
(10A)

Bottom group
(15A)

Fuses

Each of the modules and sockets are grouped with a fuse for safety.

If any of the fuses need replacement, be sure to replace it with the correct value :

Top group	: 5A
Middle group	: 15A
Bottom group	: 15A
Charger fuse	: 10A

Remote Monitor - (Optional accessory)

The Remote Monitor provides status about the system on a high-contrast LCD screen.

Information such as Main and Auxiliary battery voltages, charge mode, charge current, battery type, battery temperature and error conditions are displayed in a choice of 3 user-selectable display modes.

In addition to the selectable screen modes, the user is able to increase or decrease the screen brightness and choose to turn the display on or off.

The screen will turn off automatically when the system is idle. It will turn on automatically when the next charge cycle starts.

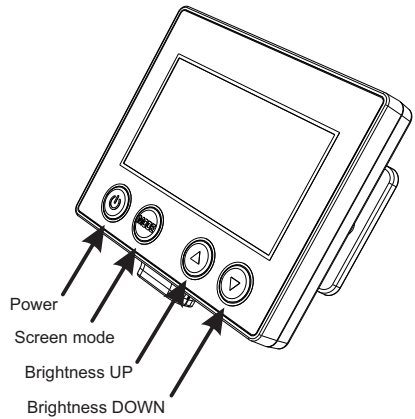

Connecting the Remote Monitor

Lift the dirt cover on the Remote Monitor port.

Connect the square end of the monitor data cable to the remote port as indicated (*fig 1*). It can fit in one direction only.

Press the plug until it clicks securely.

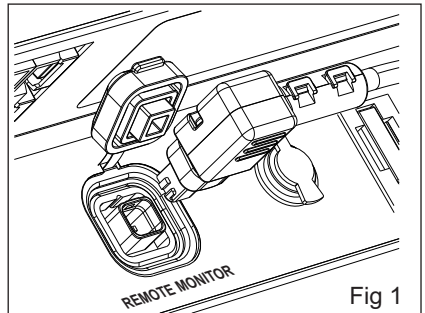

Fig 1

Connect the flat end of the data cable to the Remote Monitor. (*fig 2*).

This connector can fit both ways.

Locate the Remote Monitor in a convenient location using the supplied mounting fixture.

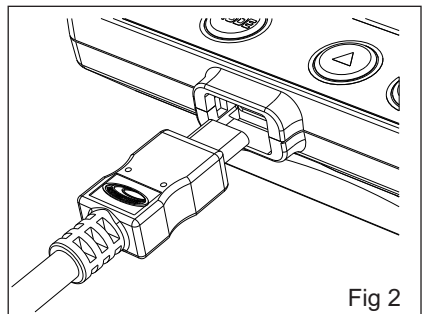

Fig 2

Remote monitor operation

The remote monitor can be turned ON or OFF by pressing the **POWER** button.

The display will turn off automatically after a short delay if there is no active charge cycle.

The display brightness can be increased or decreased by pressing the **UP** or **DOWN** buttons.

The remote monitor has 3 display modes that represent the status of the charging system in different ways.

Press the **MODE** button to cycle through the different display options.



Display mode 1 - This mode focuses on the auxiliary battery with the majority of the screen used to show the auxiliary battery voltage and battery temperature.

The input source (ALT or SOLAR) as well as charge current is displayed during a charge cycle.

If SOLAR is the active charge source, the solar panel voltage is displayed. If there are no active charge cycles, "STBY" is displayed.

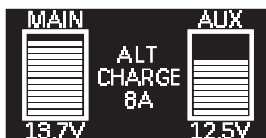

Display mode 2 - In this mode, the status of the main and auxiliary batteries are represented as graphical bar-graphs. The actual voltages are shown for the respective batteries.

During a charge cycle, the input source (ALT or SOLAR) is displayed with the actual charge current.

If there is no active charge cycle, "STANDBY" is displayed.

The AUX graph is animated during charge and represents the battery state of charge.

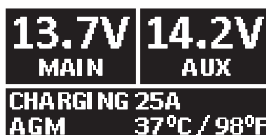

Display mode 3 - This mode shows voltages of the respective main and auxiliary batteries as well as charger mode, charge current, battery type and battery temperature.

If there are no active charge cycles, "STBY" is displayed.

Remote monitor STATUS messages

The remote monitor will show the charge status during an active charge cycle.

During the normal bulk and absorption charge stage, the charge current will be shown as well as the input source.

During the Analysis stage, "TEST" will be shown. This stage helps to detect a defective battery.

During the Float stage, "FLOAT" is shown.

Warning Messages

The remote monitor will respond and indicate various error conditions that may occur under normal operation. These warnings should be investigated to prevent damage to the batteries or the Power Pack.

The following symbols or messages may appear on any of the 3 display modes :



LOW BATTERY or NO BATTERY - This symbol is displayed when either the Main or Auxiliary battery voltage is lower than 11.4V or there is no connection to one of the batteries.

Check fuses and connections to both batteries. Ensure the main switch is ON when in use.

If this symbol and voltage display are flashing, the battery is not holding charge and should be tested.

OVP - OVER VOLTAGE PROTECTION - The voltage applied to the SOLAR or ALT inputs is too high. Ensure the applied voltages are within specification. *Refer to specifications on page 13.*

OTP - OVER TEMPERATURE PROTECTION - The detected auxiliary battery temperature is above 60°C. Charging is stopped to prevent damage to the battery.

This error will also be displayed if the Power Pack internal circuit temperature is above 115°C. Charge will stop until the system temperature recovers to a safe level.

OCP - OVER CURRENT PROTECTION - The detected charge current is higher than specification. Inspect the installation for cable faults or short-circuits.

REV - REVERSE POLARITY - The connections to the auxiliary battery have been reversed. Check the battery connections.

BAD - BAD BATTERY - The Power Pack has detected that the AUX battery is not able to be charged safely. Test the battery and replace if necessary.

Please check cable The plug to the remote monitor may not be inserted correctly. Ensure it is fully inserted.

Specifications

Voltage Range		
MAIN BATT input	11V - 32V	
SOLAR PANEL input	9V - 42V	
Solar Regulator		
Type	MPPT	
Output Current	25A	
Output Power	375W	
12V Alternator Input		
Turn ON	13.2V	
Turn OFF	12.6V	
Over-Voltage	14.8V - 16V	
24V Alternator Input		
Turn ON	26.4V	
Turn OFF	23.2V	
Over-Voltage	29.6V - 31V	
Ignition Over-ride (12V / 24V)		
Turn ON	12.0V	24.0V
Turn OFF	11.5V	23V
Over-Voltage	15.5V - 16V	31V - 32V
Battery charge output		
Voltage	3V -14.8V	
Max Current	25A	
Max Power	375W	
Operating Temperature	-20°C to 85°C	
Standby Current (switch ON)	< 35mA	
Dimensions	257mm x 261mm x 120mm	
Battery Gauge display range	10.7V - 14.7V	
USB charge output (each port)	5V-3A, 9V-2A, 12V-1.5A	
Remote Display	Optional	
Battery Types	Bulk Voltage	Float Voltage
AGM / Gel	14.4V	13.6V
Standard Wet	14.6V	13.6V
Calcium	14.8V	13.6V
Lithium Ion	14.4V	13.6V

Battery Temperature Compensation	
High temperature	-17mV per °C above 30°C
Low Temperature	+17mV per °C below 21°C
Battery over-temperature protection	60°C
Device Protection	
Reverse Polarity	
Over Voltage	
Over Current	
Over Temperature	
Bad Battery Detect	

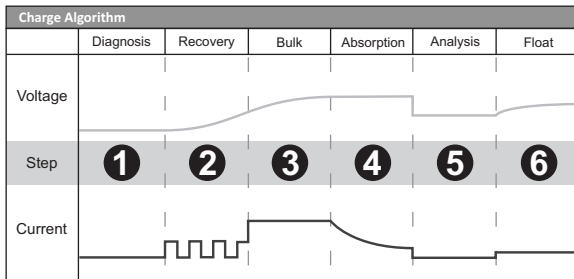

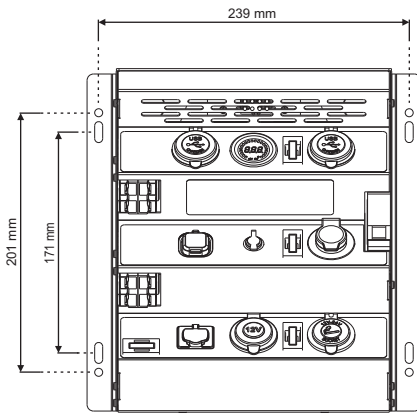
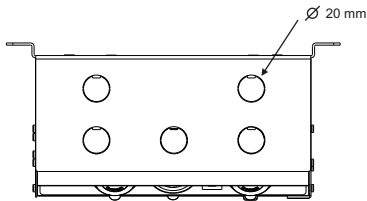
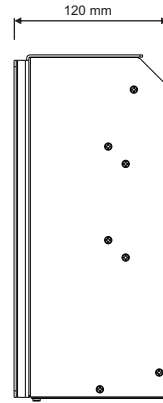
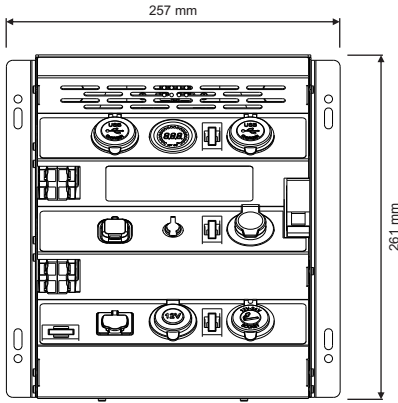

Mounting hole locations

National Luna Limited Warranty - South Africa

This National Luna Warranty supersedes any other advertised Guarantee or Warranty provided with this appliance by any wholesaler or retailer.

National Luna warrants this product to be free from defects in materials and / or workmanship under normal use and service to the original purchaser subject to the following :

1. At any time within THREE YEARS from the date of purchase by the original purchaser, National Luna will at its discretion replace or repair without cost to the owner, through an authorised service agent, any part found to be defective by National Luna.
2. Where parts are replaced by an authorised service agent, the labour costs for the work done will be for the owner's account.
3. This warranty does not apply to accessories or items where the length of life depends on the amount of use and care given.
4. This warranty is valid within the borders of South Africa only.
5. National Luna may consider a warranty void if modifications have been made to this product which may cause undesirable or hazardous operation or may be the cause of the malfunction of this product.
6. National Luna shall not be responsible for any damages of any kind resulting from incorrect voltages or faults with regards to power supply which fall outside of the appliance operating specifications.
7. National Luna shall not be responsible for damage to the product caused by negligent use, storage of hazardous chemicals, use of corrosive substances, fire, flood, civil-disturbances, lightning or any other natural phenomenon.
8. Warranty returns to the factory for repairs - in the event where the unit has been shipped to the factory for repairs, transport costs will be for the owners account.
9. National Luna will not accept any responsibility for the consequential loss or damage caused by, or due to the malfunctioning of this appliance.
10. National Luna shall not be held responsible for any injuries to persons caused by the incorrect or negligent usage of this appliance.
11. Repair work to be done in terms of this warranty must be referred to National Luna for written authorisation before any work is performed.
12. National Luna reserves the right to refuse repair or service under warranty if the original proof of purchase cannot be produced.
13. Removal of serial numbers may render the warranty void.

National Luna Limited Warranty - International

The standard National Luna Warranty in South Africa cannot be applied outside the borders of South Africa.

1. National Luna has a world wide distributor network. These distributors import products and carry the warranty (at their cost) in line with the various countries' conditions of sale.
2. Cross-border customs and duties apply. A National Luna manufactured product that is returned to the factory in South Africa will have the South African warranty applied. However, all transport costs incurred will be for the purchaser's account.
3. It is important to note that a private purchase of this product in South Africa and exported will not carry a warranty. Any labour and parts required for repairs would incur costs in foreign currency and be for the owner's account.
4. In the event of a National Luna product being fitted as standard equipment in caravans and trailers and subsequently being exported from South Africa, the warranty must be carried by the persons responsible for the importing into a country other than South Africa.
5. It is recommended that National Luna products be purchased from the authorised importer in a particular country who carries the applicable warranty and back-up service.

Replaceable Modules

The Distribution Box is designed to allow some of the plugs & sockets to be replaced with other compatible modules within the 29mm range.

The lower group can accommodate the following 29mm modules :

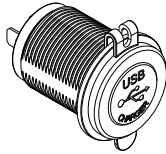
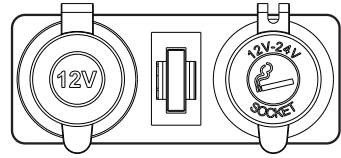

Dual USB charger

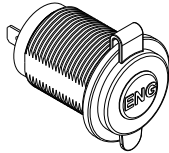

Screw-in DC socket
(Engel plug compatible)

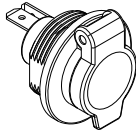

Hella-type socket

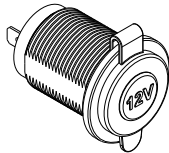

12V DC socket
(factory fitted)

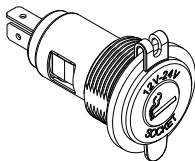

Cigarette-lighter socket
(factory fitted)

Optional Accessories



Remote Monitor



NL5 Intelligent Battery Charger

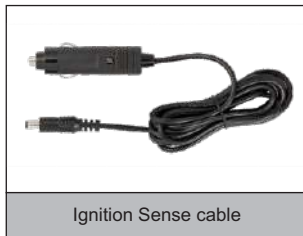

Ignition Sense cable

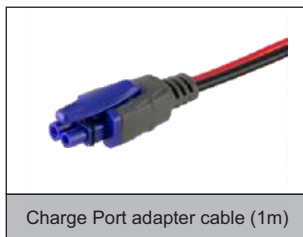

Charge Port adapter cable (1m)

**National Luna sales and support :
www.nationalluna.com**



Patents & Design registrations

South Africa : 2018/06290 ; F2017/01515 ; F2017/01516
Australia : 2018232986 ; 201811491 ; 201811492

BMS-20300 JULY 2021