

LRDR1A

LAND ROVER

Rear suspension package Ensemble pour suspension arrière Ensemble para suspensión de trasero

INSTALLATION INSTRUCTIONS

- Raise vehicle allowing the axle to hang freely.
- Remove existing bump stop assembly & retain fasteners.
- Assemble Aeon rubber spring and bracket as shown in adjacent diagram.
- Mount Timbren assembly using OEM fasteners.
- Lower vehicle.

NOTES:

When removing OEM fasteners, use penetrating fluid.

Do not exceed vehicle manufacturer's recommended axle weight rating. Check for AEON interference with vehicle components - Under load AEON will "expand" in diameter.

INSTRUCTIONS DE MONTAGE

- Soulever le véhicule en laissant l'essieu pendre librement.
- Retirez l'assemblage de butée de protection existant et conservez les fixations.
- Assemblez le ressort en caoutchouc Aeon et le support comme indiqué dans le diagramme ci-contre.
- Monter l'assemblage Timbren en utilisant des attaches OEM.
- Véhicule inférieur.

REMARQUES:

Utiliser un fluide pénétrant, au moment de retirer la boulonnerie du fabricant d'équipement.

Ne pas dépasser le poids nominal sur l'essieu recommandé par le fabricant du véhicule. Vérifier que le ressort AEON n'a pas d'incidence sur d'autres pièces du véhicule - Le ressort AEON augmentera son diamètre avec la charge.

INSTRUCCIONES DE INSTALACIÓN

- Levante el vehículo permitiendo que el eje cuelgue libremente.
- Retire el conjunto de tope de tope existente y retenga los sujetadores.
- Monte el resorte de goma Aeon y el soporte como se muestra en el diagrama adyacente.
- Montar el conjunto Timbren utilizando sujetadores OEM.
- Baje el vehículo.

NOTAS:

Al remover los elementos de sujeción del fabricante original de equipo, utilice fluido penetrante.

No exceda la carga nominal en el eje recomendada por el fabricante del vehículo. Compruebe que no haya interferencia entre el resorte AEON y los otros componentes del vehículo. Bajo carga, el resorte AEON se amplía en diámetro.

Ref. = Reference = No. de référence = Núm. de referencia
Part = Part #. = No. de pièce = Núm. de pieza
Qty. = Quantity = Quantité = Cantidad

| Ref | Part | Qty |
|-----|---------------|-----|
| 1 | A00100-65AG00 | 2 |
| 2 | K11028-003 | 2 |
| 3 | F41308-050 | 4 |
| 4 | F11534-350 | 4 |

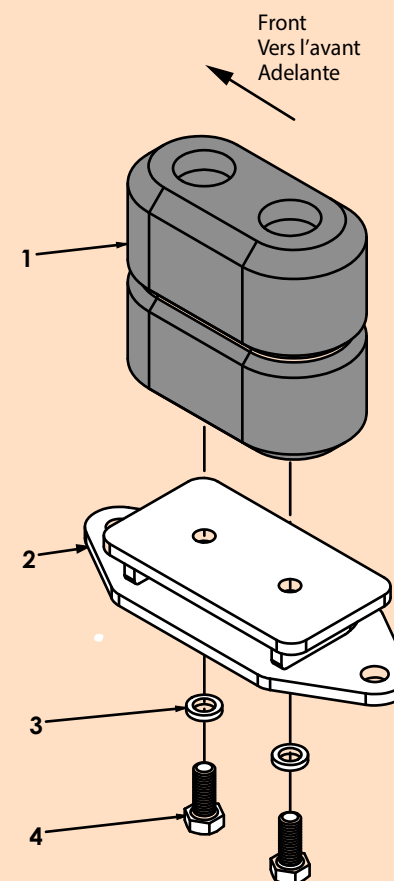

LRDR1A



LRDR1A

TIMBREN INDUSTRIES INC.

www.timbren.com

| PART NUMBER | DESCRIPTION | QTY | LOCATION |
|-------------------|---------------------------------|----------|------------|
| F41308-050 | Lock Washer Split M10 Gr. 8.8 Z | 4 | I1D |
| F11534-350 | HCS M10 x 25 x 1.5 Gr. 8.8 Z | 4 | I1C |

| | | | |
|----------------------|----------------------|----------|-------------|
| A00100-65AG00 | HOLLOW RUBBER SPRING | 2 | C13B |
|----------------------|----------------------|----------|-------------|

| | | | |
|-------------------|----------|----------|------------|
| K11028-003 | Weldment | 2 | TBD |
|-------------------|----------|----------|------------|

| | | | |
|-------------------|---------------------------------|----------|-------------|
| B90201-CR | LARGE REAR BOX - 10.5 x 8.5 x 6 | 1 | A--D |
| B10000 | 8" X 12" BUBBLE FOR KITS | 1 | |
| B00029-010 | BARCODE LABEL FOR KIT | 1 | |

Issued: 4/29/2019

Clearance Instructions:

Rear SES Kits for Pick-Ups and Vans should have a 1/2" to 1-1/2" gap between the rubber spring and contact point when empty.

A partial load, or vehicle accessories will reduce or eliminate the gap.

Front SES kits are usually in full contact.

Medium and Heavy-Duty Trucks, Trailers and Motorhomes will be in constant contact, and have no gap.

Lifetime Warranty:

Timbren SES Kits are warranted against defects in material and workmanship, under normal use and service, for the life of the vehicle on which the kit was originally installed. The warranty is not transferable and proof of purchase is required. The warranty is limited to the replacement of the failed part.

TIMBREN will not be responsible for any labour or freight charges involved in the replacement of any product. TIMBREN shall be entitled to make its own inspection to determine the validity of the claim. TIMBREN shall not be liable nor warranty the product in the event of alteration, misuse, overload, negligence or damage caused by others.

If ride or performance of our product is unsatisfactory in any way, please call: 1-800-263-3113 or email sales@timbren.com

ASSEMBLY NOTES: