



Model SR3500SXX

3500 lbs Capacity
Single Axle

Installation Instructions

IMPORTANT:

- ◆ Aeon rubber spring is factory pre-loaded. This pre-load will be lost if control arm pivot bolt loses its torque. In case of service, bolt must be re-torqued only when Aeon spring is fully loaded as per OEM instructions.
- ◆ Axle seats must be welded to axle after U-bolts are torqued. Do not weld U-bolts

Procedure:

- 1) Mark frame rails at each side where centerline of axle should cross frame (fig.1).
- 2) Locate left and right frame brackets on frame rails, opposite to each other. The inboard faces of each frame bracket must mate corner faces of frame rail (fig. 2). Move frame brackets along frame until the center of axle seats line up with marks on the frame rails, viewing from top. Clamp frame brackets to frame.
- 3) Position axle on axle seats and install U-bolts around axle. Insert washers and nuts. Tighten nuts until snug. The arch (or camber) on axle must be facing up when trailer is right side up. Slide axle on axle seats and center it to trailer frame. Ensure that the contact area of U-bolts on axle is free of grease, oil, etc.
- 4) Install crossmember: Make a crossmember using a 2"x2"x3/16" structural steel tube section. Locate crossmember at front face of LH and RH hangers, as shown in (fig. 2) and secure it to hanger using bolts, washers and nuts.
- 5) To align axle, measure and compare distances "A" and "B" (fig. 1) and make sure that the error (the difference between "A" and "B") is no more than 1/8". If the error is greater than 1/8" reposition frame brackets and recheck.

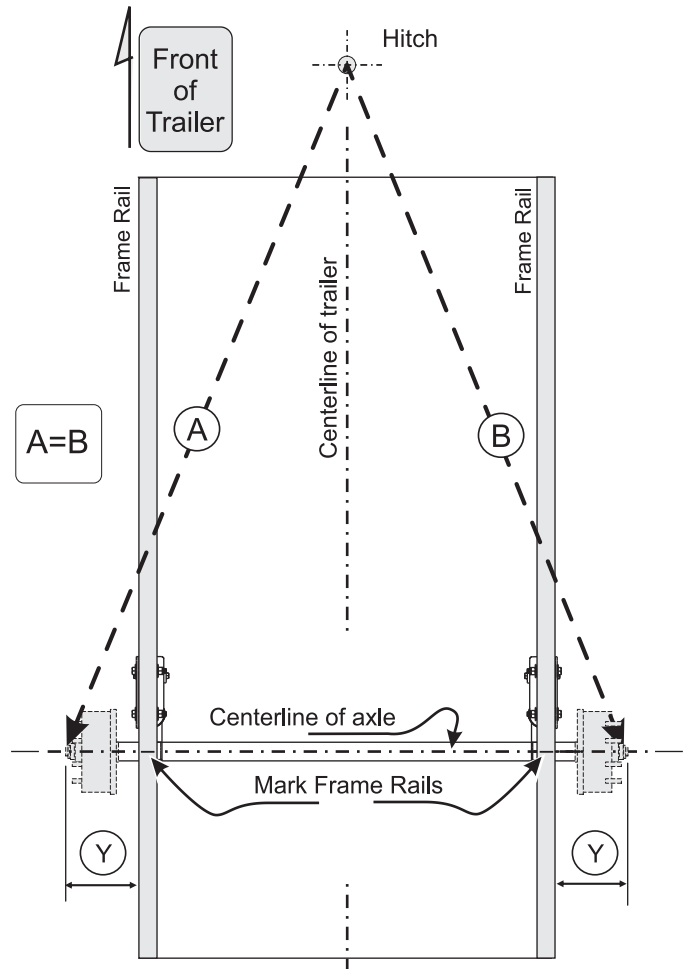

Fig. 1 Axle alignment (View from Top)



Model SR3500SXX

3500 lbs Capacity

Single Axle

Installation Instructions

Procedure: (Cont.)

- 6) Once axle is aligned, torque U-bolts to 70-75 ft-lbs in a crisscross pattern. Drill two holes in the frame at each side using holes of frame bracket as a template. Use 5/8" UNF (grade 5 min.) bolts, lock-nuts, and 5/8" washers to mount frame brackets to frame (fasteners are not included). Torque mounting bolts to 165-175 ft.lbs.
If trailer main frame is made from rectangular hollow sections, reinforce it by adding clamp plates to the inboard side of frame so that it does not collapse under compression of bolts.
- 7) Weld axle seats to axle (along axle only), as shown in fig.2. **DO NOT weld U-bolts.**
- 8) Remove clamps.

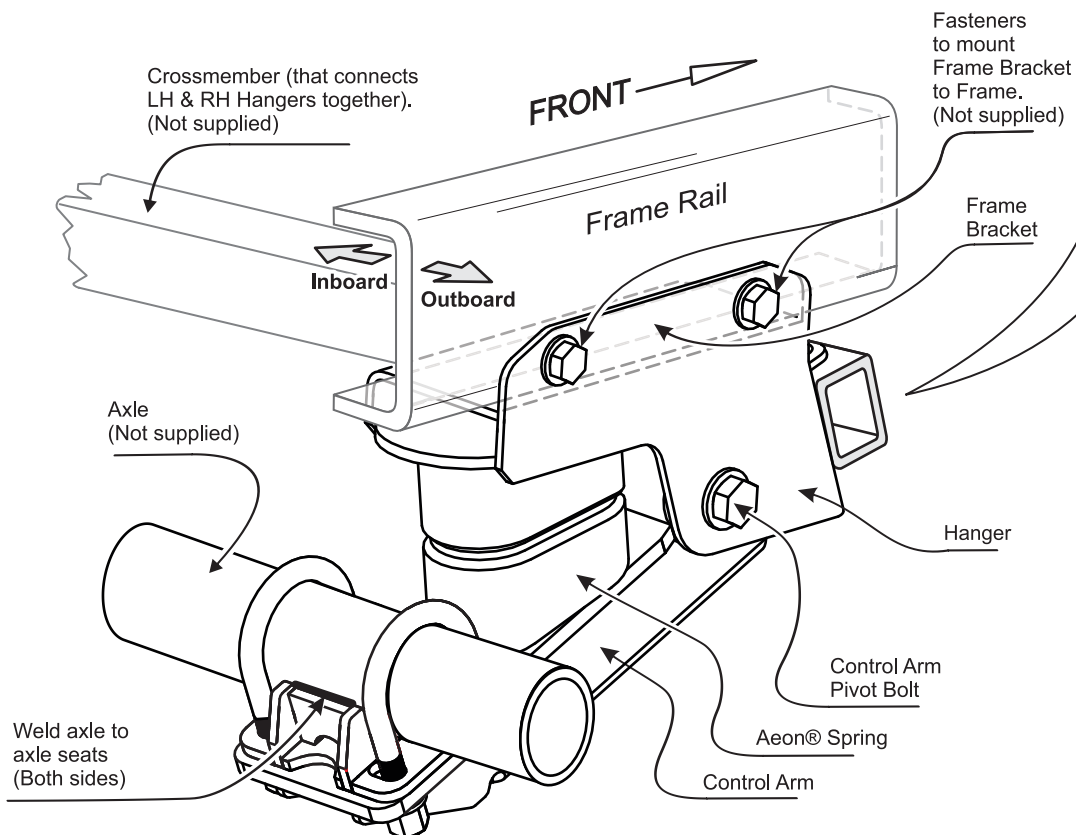
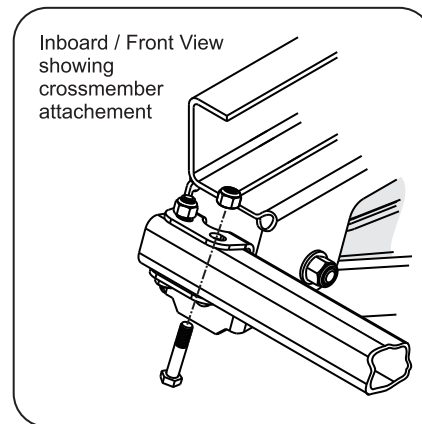

Fig. 2 View of the right-end side suspension on the trailer