



Model SR7000T, SR7K31T & SR7K35T series Equalized Tandem

Installation Instructions

IMPORTANT:

- ◆ Reinforce trailer frame in section areas between front and rear axles. (Remember that each suspension hanger carries the combined share load of both axles at each side).
- ◆ Use extra caution in case you need to disassemble the suspension; be aware that both Aeon rubber springs (Jounce and Rebound) are factory pre-loaded.
- ◆ Axle seats must be welded to axle after U-bolts are torqued. Do not weld U-bolts

Procedure:

1. Mark frame rails where center of tandem (centerline of tandem axles) should cross frame (fig. 2).

Procedure: (Cont.)

2. Locate hangers on frame rails, opposite to each other. Mate inboard corner faces of each hanger with outboard corner faces of its corresponding frame rail (fig. 1). Move hangers along frame until center of hanger lines up with mark on frame rail at each side. Clamp hangers to frame.
3. Position axle on axle seats and install U-bolts around axle. Insert washers and nuts on the opposite side of control arm plate. Tighten nuts until snug. The arch (or camber) on axle must be facing up when trailer is right side up. Slide axle on axle seats and center it to trailer frame. Ensure that the contact area of U-bolts on axle is free of grease, oil, etc.

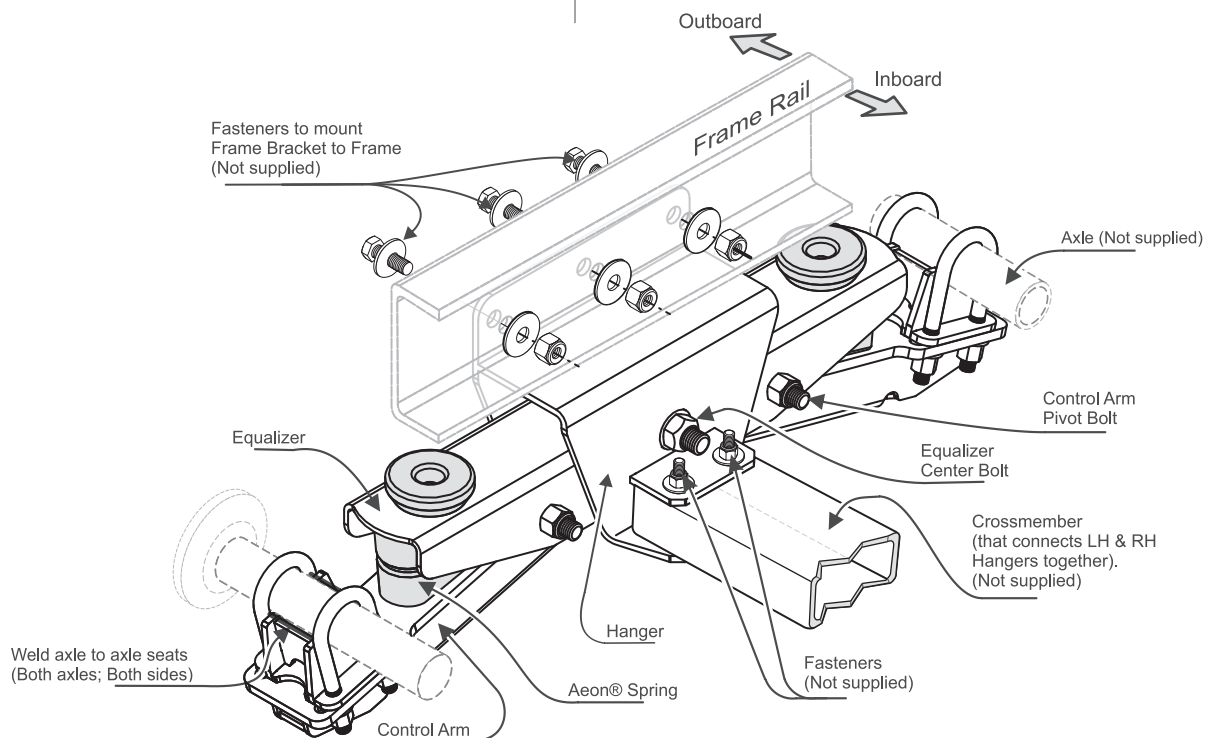

Fig. 1 Installation of suspension to trailer frame
(one side shown only, perspective view from inboard)



Model SR7000T, SR7K31T & SR7K35T series Equalized Tandem

Installation Instructions

Procedure: (Cont.)

4. Install crossmember: Make a crossmember using a 2"x4"x3/16" Hollow Structural Steel, ASTM A500 Grade C or G40.21 Grade 350W). The length of crossmember must be the measured width of trailer frame less 10-1/2". Locate crossmember between hangers: position each end of it between two horizontal plates that are attached to inboard side of hanger. Make sure hangers are perpendicular to bottom surface of trailer. Tack weld and then weld crossmember to hangers (weld from top and bottom). Crossmember can also be bolted to hanger (fig 1): use existing holes as a template to drill holes. Use 1/2" bolts (3-1/4" long), washers and nuts to attach crossmember to hangers. Apply a full torque of 70-75 ft- lbs to each nut.
5. To align axle, locate the left hand and right hand side hangers on frame rails, opposite to each other. Move hangers along frame until center of spindles line up with marks on the frame rails, viewing from top (fig. 2). Clamp hangers to frame. Measure and compare distances "A" and "B". Reposition hangers until the difference between "A" and "B" measurements is less than 1/8".
6. Once axles are aligned, torque U-bolts to 70-75 ft-lbs in a crisscross pattern. Drill three holes in the frame at each side using holes of hanger as a template. Use 5/8" (grade 5 min.) bolts, lock-nuts, and 5/8" washers to mount frame brackets to frame (fasteners are not included). Torque mounting nuts to 165-175 ft.lbs. If trailer main frame is made from rectangular hollow sections, reinforce it by adding clamp plates to the inboard side of frame so that it does not collapse under compression of bolts.
7. Weld axle seats to axles (along axle only), as shown in fig. 1. Use 3/16" fillet weld. Use weld material E70XX.

DO NOT weld U-bolts.

8. Remove clamps.

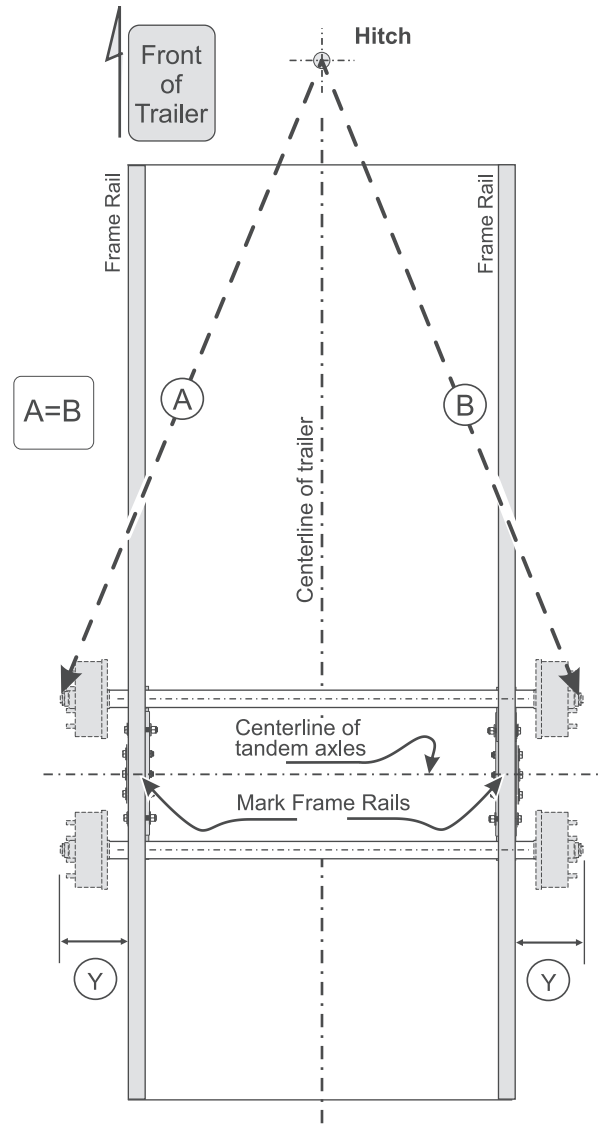

Fig. 2 Axle Alignment (View from the top)