

AXLE-LESS

TRAILER SUSPENSIONS



Product Guide

Escape The Ordinary

Explore. Discover new territory. Do something a little out of the ordinary. You want to go off-road? Maybe plan an epic overland adventure?

In order to pursue your adventure, you're going to need (among other things) a proper trailer. A trailer that can go where you want to go.

Needless to say, you're going to need something out of the ordinary.

You're going to need the Axle-Less trailer suspension. Why? Because there's no thru axle. And when you're exploring off-road, that can make a world of difference.

Escape the ordinary!



Cut From A Different Cloth

Escape to a completely new experience in trailer suspension technology. The Axle-Less suspension meets a much higher standard in efficiency, quality, and originality. Discover the freedom of the Axle-Less suspension.

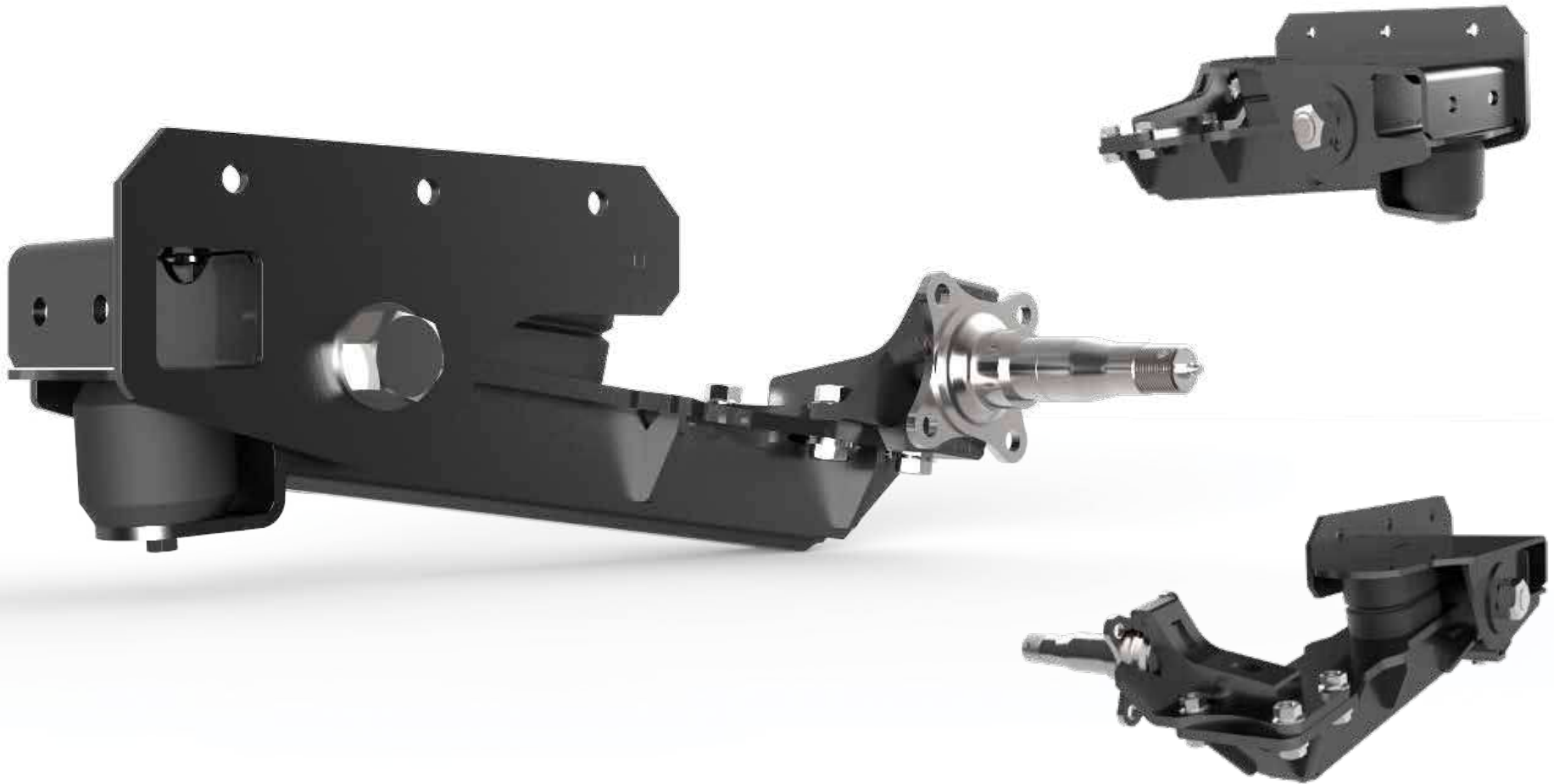



1200 Series

The 400 & 1200 series may be small, but are versatile. The lighter capacity makes them a natural choice for smaller utility or camping trailers. The durability and quality of the Axle-Less suspension ensures it will stand up to whatever abuse is thrown at it.



These series come complete with either a regular straight spindle for a standard wheel & tire combination, or a long, straight spindle to accommodate wide wheel & tire combos.



2000 & 3500 Series

The 2000 & 3500 series Axle-Less suspensions are perfect for landscape, boat and RV trailers. The 4" drop outboard arm option brings the bed of the trailer down to a height that is easier for loading and unloading on landscape trailers and boat trailers.

If you design trailers, the Axle-Less suspension could be the ingredient that takes your next trailer project to another level. The 2000 & 3500 series options include a regular straight, 4" lift and 4" drop outboard arm.





2000HD & 3500HD Series

When your adventure getaway involves something out of the ordinary, you're going to need our beefed-up HD series. The heavier design of the HD series enables your trailer to endure the abuse of the world's harshest trails. Whether you're in the rugged Australian outback or the harsh climate of northern Canada, the HD series will carry you where you need to go and back again.

The HD series offers 5 outboard arm configuration options. For the maximum in off-road capability you can use the 4" lift option (for better clearance), and a longer spindle to accommodate wide wheel and tire combinations.

See last page for available outboard arm options.



1 Metric Tonne HD Series



The 1 Tonne HD series gives you the ability to go farther off road than you ever thought possible. This is our most rugged suspension designed for the most adventurous spirit. Add the 1 Tonne HD to your trailer before you head off into the wild, off road region of your choice.

The 1 Tonne HD series suspension comes equipped with a longer trailing arm. This allows for more suspension travel. In other words, it smooths out the rough, overland trails ensuring greater comfort and safety.



5200 & 7000 Series



The most exciting thing about the Axle-Less suspension is just that – no axle! This unique idea opens the door to new trailer designs and configurations. Whether you lower your trailer to the ground, or give it more ground clearance – just about anything is possible.

Everything from boat trailers to horse trailers, the Axle-Less suspension is the way to go. If there's no axle, there's no more hub face-to-hub face measurements. Building a trailer is easier: pick your suspension, bolt it on and you're done.



Steel Hanger

Laser-cut holes in hanger for easy, bolt-on installation. 2" square hole allows use of steel pipe for frame reinforcement.

Finish

All models available galvanized or powder coated.

Jounce Spring

Natural rubber compound creates smooth and quiet ride at all times. Unique shape & progressive spring rate allows for variable load conditions.

Built-In Camber

Camber appropriate to the suspension capacity has been built into the design of all models.

Easy Lube Spindle

Designed for easy maintenance. Shoot grease through easy-access nipple for maximum lubrication.

Rebound Spring

Small, rubber spring creates constant tension on jounce spring. Full or empty, your trailer maintains a smooth ride.

Bushings

Premium urethane bushings have small grooves allowing grease to lubricate pivot point effectively.

Outboard Arm

Break a spindle? No problem! Four bolts allow you to switch outboard arm configuration easily.

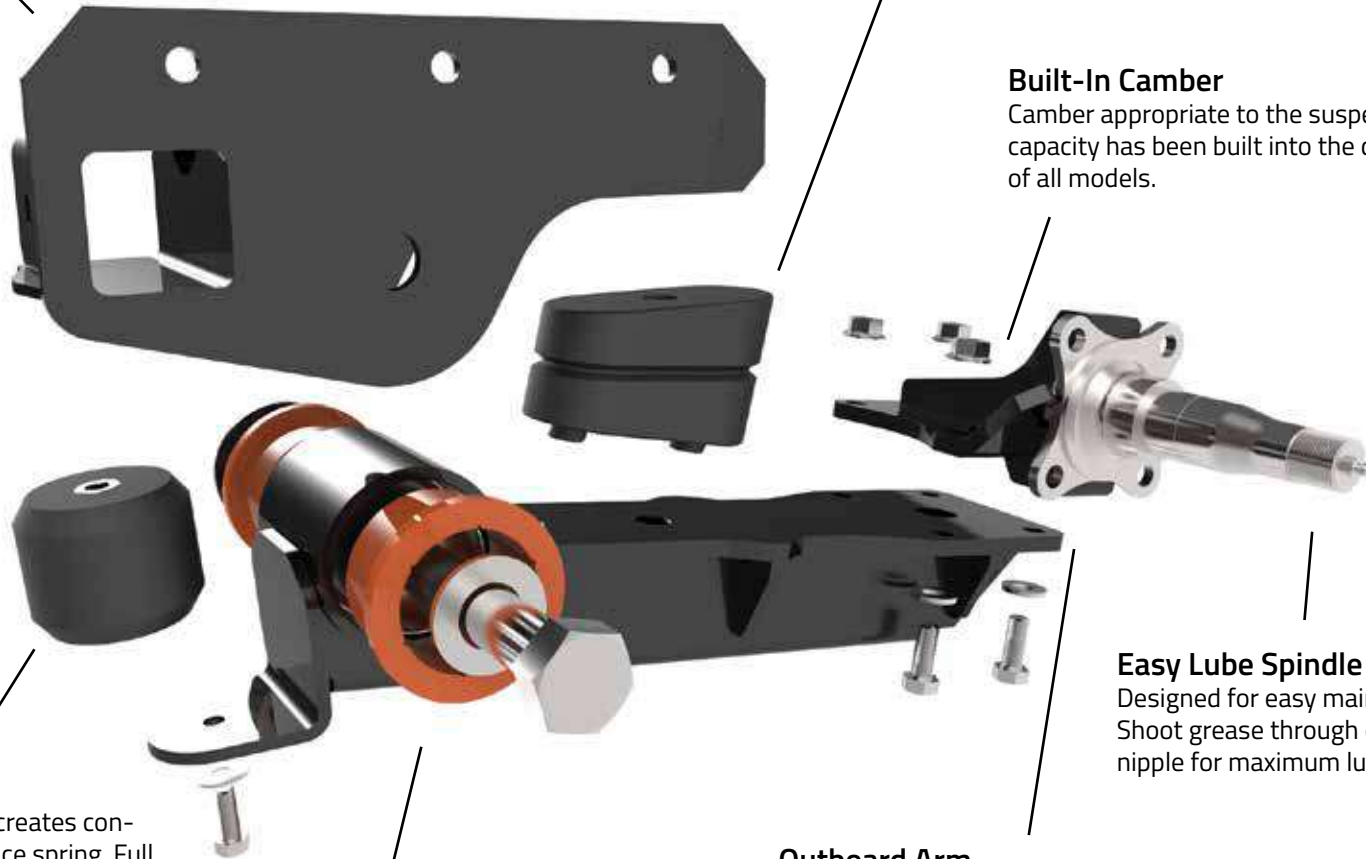

Outboard Arms

We make every effort to meet our customer's requirements. Planning to stick to the pavement? Make use of the regular straight spindle. Need to get the trailer deck as low as possible or maybe maximize ground clearance for an off-road adventure? You will find a wide range of options when it comes to Axle-Less outboard arms.



Regular Straight



Long Straight



2" Lift



2" Lift Long



4" Lift



4" Lift Long



4" Drop



4" Drop Long

It's About Adventure

There's a world of off-roading to discover. And you're willing to do what it takes to get there. But you don't want anything holding you back.

Imagine the freedom to go where you want to go. The Axle-Less suspension gives you the ability to go farther than you ever thought possible. Feel the excitement when you finally pursue your off-road adventure. Because after all...

It's all about the adventure!



Axle-Less Suspension Quick Reference

1200 Series	c/w regular straight spindle	ASR1200S02
1200 Series	c/w regular straight spindle & brake flange	ASR1200S04
2000 Series	c/w regular straight spindle	ASR2000S01
2000 Series	c/w regular straight spindle & brake flange	ASR2000S02
2000HD Series	c/w regular straight spindle & brake flange	ASR2KHDS01
2000HD Series	c/w long straight spindle.....	ASR2KHDS02
2000HD Series	c/w 2" lift 4400 lb. regular spindle & brake flange.....	ASR2KHDS13
2000HD Series	c/w 4" lift long spindle & brake flange	ASR2KHDS03
2000HD Series	c/w 4" lift 4400 lb. long spindle & brake flange	ASR2KHDS12
2000HD Series	c/w 4" lift regular spindle & brake flange.....	ASR2KHDS04
2000HD Series	c/w 4" drop regular spindle & brake flange	ASR2KHDS05
2000HD Series	c/w 4" drop long spindle & brake flange	ASR2KHDS09
1 Tonne HD Series	c/w regular straight spindle & brake flange	ASR1THDS01
1 Tonne HD Series	c/w long straight spindle & brake flange	ASR1THDS02
1 Tonne HD Series	c/w 2 lift 4400 lb. regular spindle & brake flange	ASR1THDS13
1 Tonne HD Series	c/w 4" lift long spindle & brake flange	ASR1THDS03
1 Tonne HD Series	c/w 4" lift 4400 lb. long spindle & brake flange	ASR1THDS12
1 Tonne HD Series	c/w 4" lift regular spindle & brake flange.....	ASR1THDS04
1 Tonne HD Series	c/w 4" drop regular spindle & brake flange	ASR1THDS05
1 Tonne HD Series	c/w 4" drop long spindle & brake flange	ASR1THDS09
3500 Series	c/w regular straight spindle & brake flange	ASR3500S05
3500 Series	c/w 2" lift regular spindle & brake flange.....	ASR3500S08
3500 Series	c/w 4" lift regular spindle & brake flange.....	ASR3500S06
3500 Series	c/w 4" lift long spindle & brake flange	ASR3500S07
3500 Series	c/w 4" drop regular spindle & brake flange	ASR3500S04
3500HD Series	c/w regular straight spindle & brake flange	ASR35HDS04
3500HD Series	c/w long straight spindle & brake flange	ASR35HDS01
3500HD Series	c/w 4" lift long spindle & brake flange	ASR35HDS02
3500HD Series	c/w 4" lift 4400 lb. long spindle & brake flange.....	ASR35HDS08
3500HD Series	c/w 4" lift regular spindle & brake flange.....	ASR35HDS05
3500HD Series	c/w 2" lift long spindle & brake flange	ASR35HDS06
3500HD Series	c/w 2" lift regular spindle & brake flange.....	ASR35HDS07
3500HD Series	c/w 2" lift 4400 lb. regular spindle & brake flange.....	ASR35HDS09
3500HD Series	c/w 4" drop regular spindle & brake flange	ASR35HDS03
3500HD Series	c/w 4" drop long spindle & brake flange	ASR35HDS11
5200 Series	c/w regular straight spindle & brake flange	ASR5200S01
5200 Series	c/w 2" lift regular spindle & brake flange	ASR5200S05
5200 Series	c/w 4" lift regular spindle & brake flange.....	ASR5200S03
5200 Series	c/w 4" drop regular spindle & brake flange	ASR5200S04
7000 Series	c/w regular straight spindle & brake flange	ASR7KS01
7000 Series	c/w 4" drop regular spindle & brake flange.....	ASR7KS02

AXLE-LESS[®] TRAILER SUSPENSIONS

TIMBREN INDUSTRIES, INC.
320 Hopkins St.
Whitby, ON, Canada
L1N 2B9

1-800-263-3113
905-444-9004
sales@timbren.com