

TRAILER AXLE-LESS SUSPENSIONS

For 1200 & 2000 Lbs.
models

Installation Instructions

IMPORTANT NOTE

◆ The AxleLess suspension provides many advantages and permits many innovative designs for trailers. There is no thru axle and therefore the two sides of suspension are completely independent. The absence of an axle tube, however, means there will need to be comparable strengthening of the trailer frame, especially at the areas where the suspension is installed. The function of a regular axle as a structural member must be compensated by strengthening / reinforcing the trailer frame itself to prevent excessive bending or twisting of the frame. At the very least this should mean that the top plate of the suspension frame bracket be fully supported and firmly fastened (bolted/welded) to robust cross members of the frame or to the inboard extension of the frame rail itself or both. Timbren will not be responsible for damage caused by insufficient strengthening of the frame⁽¹⁾.

◆ Use extra caution in case you need to disassemble the suspension; be aware that both Aeon rubber springs (Jounce and Rebound) are factory pre-loaded.

◆ AxleLess suspensions are NOT recommended for tri-axle applications. Even loading is important (Since there is no equalization between axles).

Procedure:

1. Install outboard arm on control arm using 4 bolts and washers and shims as required (fasteners are included). Fig. 1 shows what the right hand side should look like; the left hand side is the mirror image. Torque fasteners to 70-75 ft-lbs (95-102 N.m). Skip this section if outboard arm is factory pre-assembled.

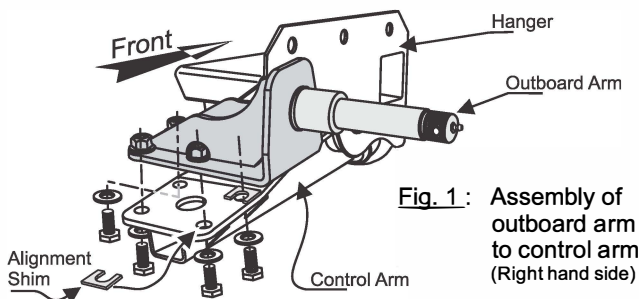

Fig. 1: Assembly of outboard arm to control arm (Right hand side)

2. Make sure frame is perfectly square. Measure and compare the diagonal distances from one corner of frame to the opposite corner. Also measure and compare the distances from the hitch to each rear corner of frame. Ideally the measurements are identical (in each case the difference should be less than 1/8" (3 mm). Mark frame rails where centerline of spindles (wheels) should cross frame (fig. 2)⁽²⁾.

Procedure: (Cont.)

3. Locate the left hand and right hand side hangers on frame rails, opposite to each other. Move hangers along frame until center of spindles line up with marks on the frame rails, viewing from top (fig. 2). Clamp hangers to frame. Measure and compare distances "A" and "B". Reposition hangers until the difference between "A" and "B" measurements is less than 1/8" (3 mm).

4. Be aware that the suspension has camber angles built in. The correct alignment can be obtained ONLY if frame and its crossmembers or mounting surfaces to the suspension are perfectly square and they are sufficiently strong to remain square under maximum loads. Slight camber adjustments and corrections may be necessary by using the shims between the outboard arm and control arm before tightening the 4 bolts.

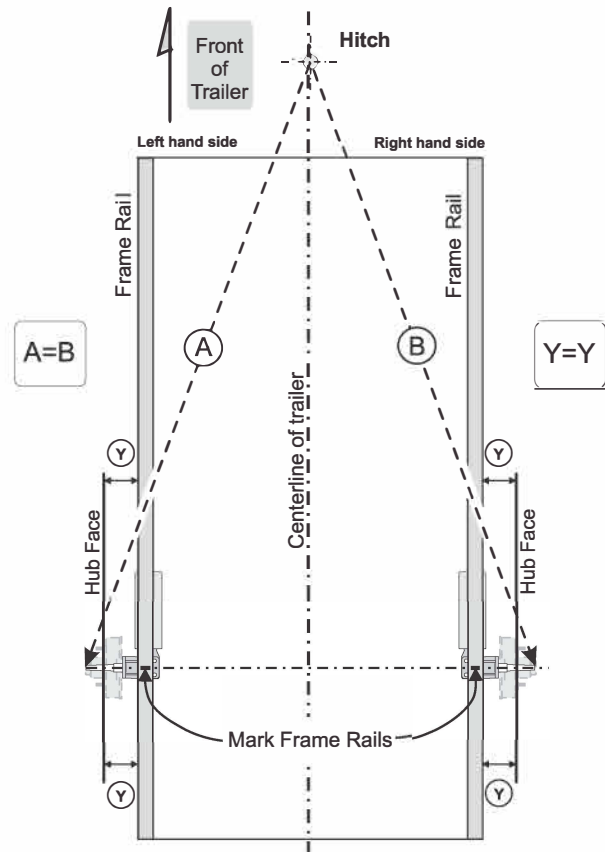

Fig. 2 Spindle Alignment (View from the top)

(1) To add rigidity to the trailer frame structure we recommend using rectangular-shape or fabricated box-form steel sections combined with crossmembers of larger sizes; ultimately it will be the trailer manufacturer's responsibility to make sure that the frame is strong enough to be used with the AxleLess suspension.

(2) Be aware that the driver side and passenger sides have their own factory built-in camber and therefore the two spindles do not need to be exactly parallel.

Installation Instructions

Procedure: (Cont.)

5. Bolt hanger side plate: ⁽³⁾⁽⁴⁾ (fig. 3): Use holes in the hanger side plate as a template (3 or 2 holes, depending on the model #). Drill horizontal holes to the side of frame at each side of trailer. Use ½" UNC (grade 5 minimum) bolts, lock-nuts, and washers to mount hangers to frame (fasteners are not included). Torque mounting bolts to 70-75 ft.lbs (95-102 N.m).

6. Do either 6a or 6b (whichever is easier or more practical):

6.a) Bolt hanger top plate to frame⁽³⁾: Hanger top plate must be in full contact with the frame so that it can be bolted to frame. Use holes in the hanger top plate as a template and drill 2 vertical holes. In case frame is not wide enough, hanger top plate can be bolted to cross members of frame instead (as long as those crossmembers are strong enough). If crossmembers exist but there is a gap between bottom surface of crossmembers and top of hanger then steel spacers (plates) should be used to fill up the gap. Drill common holes to bolt hanger to crossmembers. Use ½" UNC (grade 5 minimum) bolts, lock-nuts, and washers to mount hanger top plate to frame (fasteners are not included). Make sure bolts are long enough the entire length of nuts but they are not too long to interfere with other parts of suspension in the hanger. If trailer does not have crossmembers (but frame main beam itself is sufficiently strong to overcome torsion of frame) then fabricate an inboard extension and attach it to the frame. Reinforce it by gussets as necessary (fig. 3) to make it rigid.

6.b) Skip procedure (6.a) and install a simple suspension crossmember if one or more of the following applies:

- You are retrofitting axles / suspensions on a standard trailer;
- The design of the trailer does not allow drilling vertical holes for bolting hanger top plate;
- Frame could be aluminum; creating frame inboard extension may not be practical;
- Frame crossmembers may not be located directly above hanger top plate and modifying or relocating them is not optional procedure:

Use a 2"x2"x 3/16" (minimum) structural steel tube section. Measure width of trailer and saw cut a piece to that length. Slide tube through corresponding opening in the driver and passenger-side hangers. Drill two holes at each end and bolt suspension crossmember to hanger or weld it at each end (fig. 4).

7. Remove clamps.

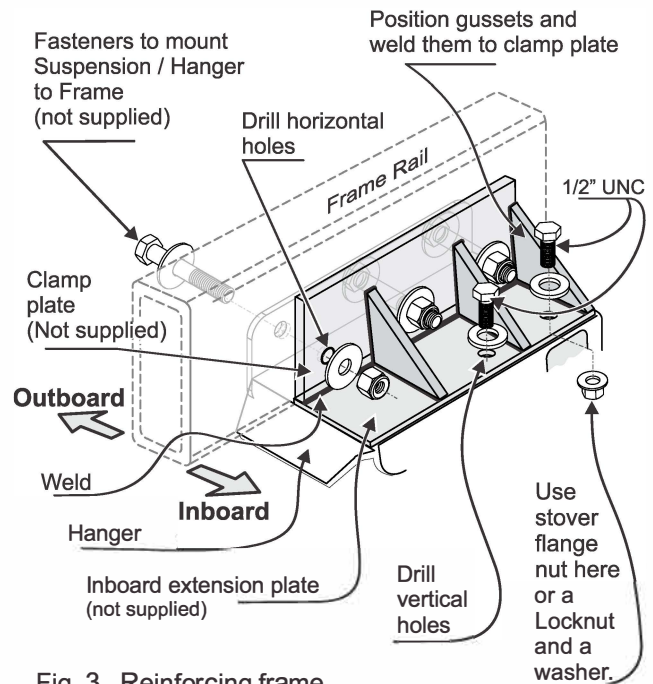

Fig. 3 Reinforcing frame

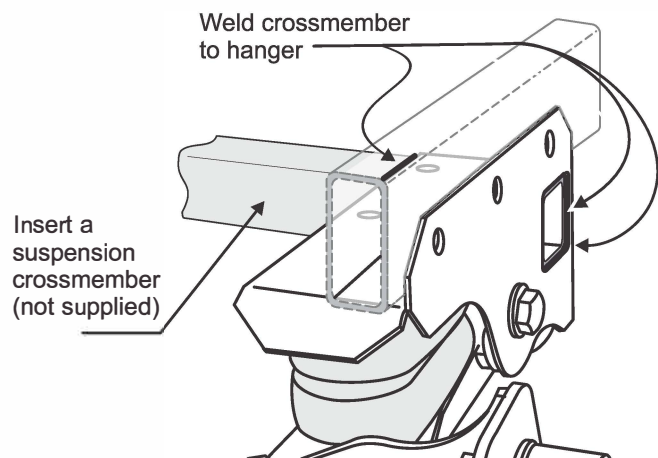

Fig. 4. Suspension crossmember installed

(3) Welding the hanger is optional (instead of bolting it), but be aware that all paint around welding edges need to be ground off prior to welding. Protect Aeon® rubber spring from extreme heat generated during welding.

(4) When bolting the frame be aware that hollow (tubular) sections of frame may not be sufficiently strong to withstand compression of bolted joints and therefore may collapse unless they are reinforced; consider fabricating a bracket similar to the one shown in fig 3 which has a clamp plate to go between the nut/head of bolt and tube. Such bracket must be rigid enough to allow you to apply a full torque to bolts.

Maintenance ^(a)



PRIOR to doing any repair, inspection, or maintenance work under the trailer:

1. Park the trailer on solid, level ground such as a concrete or paved surface. Place the vehicle in park, set the emergency brake and use wheel chocks to prevent the vehicle from moving.
2. No work may be done under any vehicle supported only by a hydraulic or mechanical jack.
3. Additional safety devices such as jack stands are required in order to provide extra protection.

Within the first week of operation:

- Retorque outboard arm (spindle) bolts to 70-75 ft-lbs (95-102 N.m).
- Retorque control arm pivot bolts to 165-175 ft-lbs (224-237 N.m).
- Retorque ALL bolts that are used to mount the hanger to frame (2 vertical bolts & 2 to 3 horizontal bolts, depending on the model #) to 70-75 ft-lbs (95-102 N.m).
- Lift the trailer, turn wheels individually by hand and make sure they are running smoothly and there is no slack in the wheels when moved side to side. Tighten spindle nut to take the slack out and re-check. Then relock it with cotter pin.

Periodic maintenance (once after 4 months, then every 12 months afterwards or sooner)

Do a complete visual inspection of the suspension / hubs. Inspect all metal components, hangers, control arms, outboard arm and frame for cracks, deformed surfaces or broken welds. Check the bearings. Repair or replace according to the manufacturers recommendations. Check the alignment. Check that all bolts are tightened to a torque specified. Repack bearings and hubs with new grease. Spinning the bearing during grease application is often recommended to evenly coat the bearing. Replace grease seals if necessary.

Bushing Lubrication

- For regular highway use, grease suspension bushings every 6,000 miles (10,000 KM) or 6 months, whichever comes first.
- For off-road use, grease suspension bushings at least every 3,000 miles (5,000km) or 3 months, whichever comes first.
- If the trailer is used only occasionally but for longer trips (on off-road or extreme terrain conditions), we advise greasing suspension bushings before each trip.

Securely lift suspension. Find grease nipple (nozzle) underneath tube of control arm where arm is attached to hanger; use grease gun / applicator (either a hand gun applicator or automatic pistol one); apply a liberal amount of grease, fill bushing housing until grease flows out at both ends of control arm. Continue until old grease has been fully replaced with new grease. Wipe excess grease.

Note: Do not mix Lithium, calcium, sodium, or barium complex greases due to the possibility of contamination problems. We recommend using Lithium Complex with NLGI No. 2 consistency.

Here is a list of a few approved suppliers and their products:

Chevron: Delo EP2 235208
Citgo: Lithoplex MP NLGI No. 2
Ashland Oil: Valvoline Val-Plex EP NLGI, No.2
Exxon/Standard: Ronex MP NLGI 2
Mobil Oil: Mobilgrease XHP™ 220 Series
Pennzoil: Pennzoil 7771 707L Premium Wheel Bearing Red Grease
Kendall: Kendall L-427

(a) Parts of this document regarding the installation and maintenance of Wheel end kits (hubs, brakes, bearings, etc.) are applicable ONLY if supplied by Timbren Industries Inc.

**Note on
 TOE-IN Alignment**

Definition of "Toe"

Toe is defined as the inward and outward angle of the tires with respect to the front of the vehicle. With toe-in, the front of the tires is closer together than the rear. Toe-out is the opposite.

Measuring Toe

While frame is upside-down and suspensions & hubs are installed:

Use two 30 inch long straight edges. Hold each against the hub face.

Measure the distance F from the front of one straight edge to the other with respect to the front of the trailer and record the measurement.

Measure the distance R from the rear of one straight edge to the other and record the measurement.

Subtract F from R to find the toe. $R - F = \text{TOE}$

If TOE is a positive number, then the suspension will be toed-in.

If TOE is a negative number, then the suspension will be toed-out.

Adjusting Toe-In

Loosen all 4 mounting fasteners of each outboard arm. Rotate outboard arm until proper toe is reached (see Proper Toe Criteria). Torque bolts as per specified values in the installation instructions.

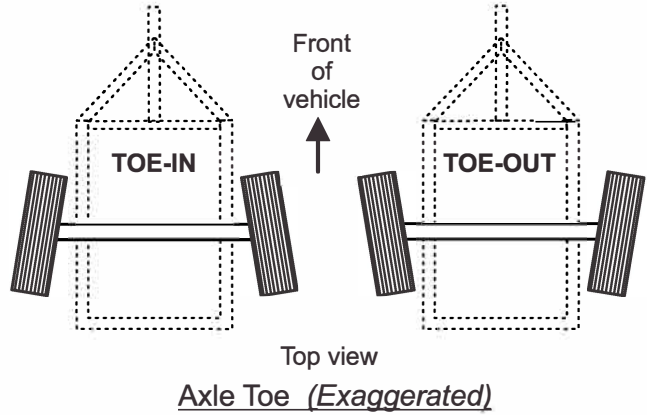

CRITERIA

0" ≤ (TOE-IN) ≤ +1/16"

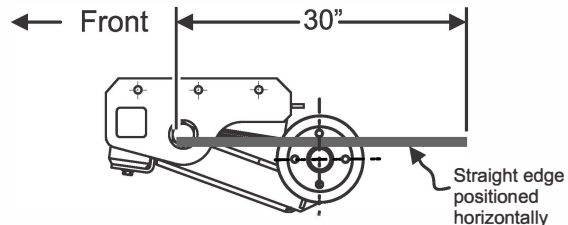

Side view of suspension

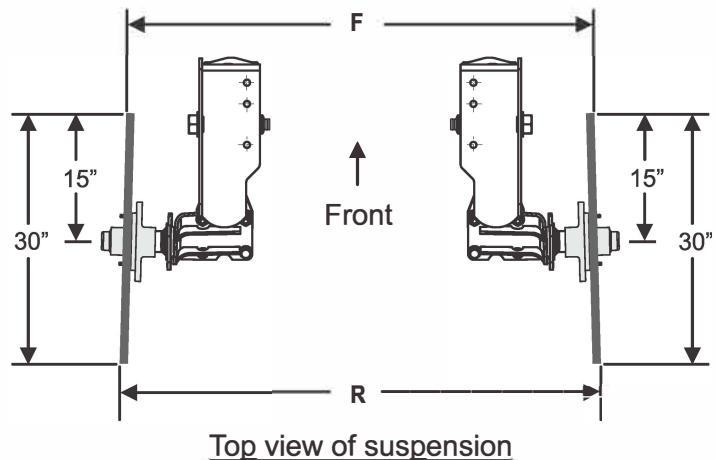
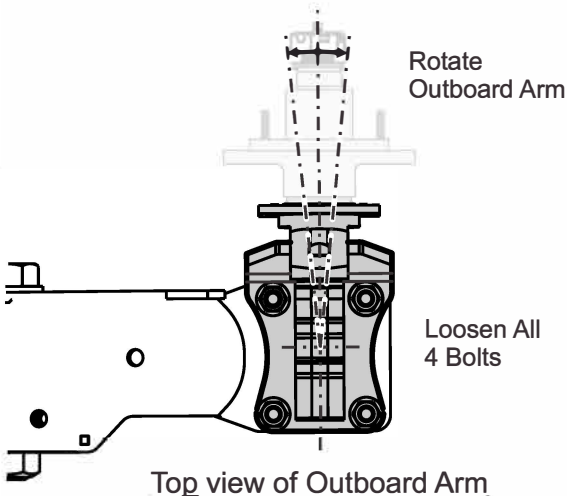

Top view of suspension