

— Instruction Manual —  
PR98SHT, PR98SHTJR AND PR98SXLHT



Bracket to install Steel Backboard on HangTime Systems

Customer Service  
(800) 247-7668

PARTS LIST					
**Packaged Separately					
Item	Qty	Description	Item	Qty	Description
A	1	Steel Backboard**	I	2	7/16" X 1 1/2" Carriage Bolt
B	1	Extension Arm**	J	2	7/16" Flat Washer
C	2	Parallel Linkage**	K	2	7/16" Lock Washer
D	1	Rim**	L	2	7/16" Hex Nut
E	1	Steel Board Bracket	M	4	3/8" X 1 1/2" Hex Bolt
F	1	Top Pivot Bolt**	N	8	3/8" Flat Washer**
G	1	Bottom Pivot Bolt**	O	4	3/8" Lock Washer**
H	2	Lock Nut**	P	4	3/8" Hex Nutt**

- ◆ Inspect all contents prior to installation. Report any missing parts to dealer immediately.
- ◆ Read all instructions before proceeding.

**Notice:**

**Follow the instructions provided with the HangTime pole system through instruction #9 to install/assemble vertical pole and main extension arm assembly. Use these instructions in place of instruction #10 to install the PR98SHT bracket and steel backboard. Continue with instruction #11 provided with the HangTime pole system to complete assembly.**

1. Use *Bottom Pivot Bolt* (G), *Top Pivot Bolt* (F) and *Lock Nuts* (H) to attach *Steel Board Bracket* (E) to *Extension Arm* (B) and *Parallel Linkages* (C). Do not overtighten hardware, make sure the *Extension Arm* (B) and *Parallel Linkages* (C) pivot and adjust up and down freely. See Figure 1.
2. Hang *Steel Backboard* (A) over the top lip of *Steel Board Bracket* (E). Use *7/16" X 1 1/2" Carriage Bolts* (I), *7/16" Flat Washers* (J), *7/16" Lock Washers* (K) and *7/16" Hex Nuts* (L) in the top two holes of *Steel Backboard* (A) and *Steel Board Bracket* (E). Hand tighten hardware at this time. See Figure 1.
3. Use *3/8" X 1 1/2" Hex Bolts* (M), *3/8" Flat Washers* (N), *3/8" Lock Washers* (O) and *3/8" Hex Nuts* (P) to install *Rim* (D). Hand tighten hardware at this time. See Figure 1.
4. Level *Steel Backboard* (A) and *Rim* (D). Tighten all hardware.

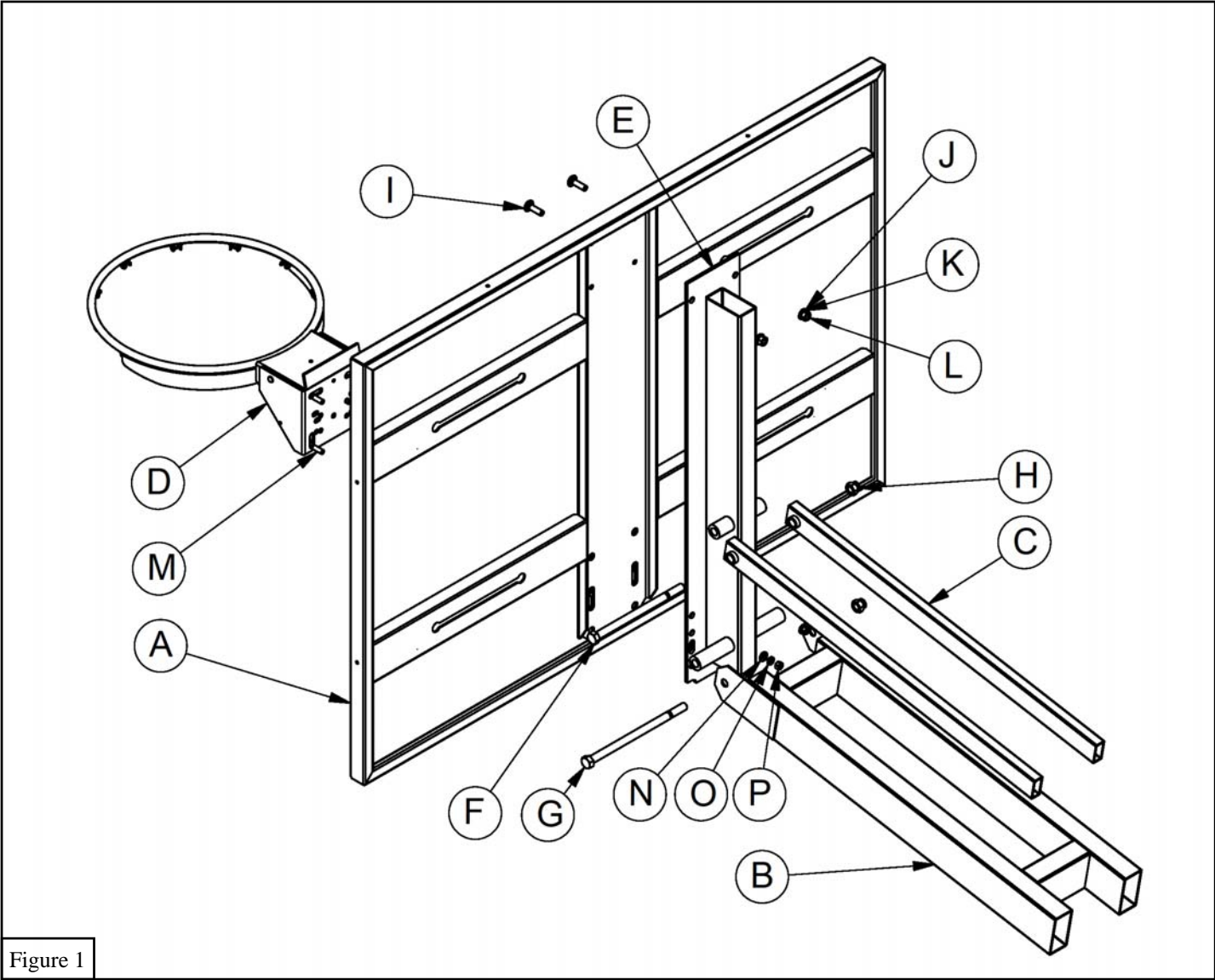

Figure 1