

PristineHydro™

WRS-UC5

WATER REVIVAL SYSTEM INSTALLATION MANUAL



TABLE OF CONTENTS

• Purchase Records	4
• Introduction	5
• Component List	6
• Diagram	7
• Specifications	8
• Quick Connect Guide	9
• Installation STEP 1	
Angle Stop Valve	10
• Installation STEP 2	
Drain Saddle Valve	11
• Installation STEP 3	
Faucet	12
• Installation STEP 4	
Water Storage Tank	13
• Installation STEP 5	
Component Placement	14
• System Connections	15
• Start-Up	17
• Filter Replacement Schedule	18
• Filter Replacement Procedure	19
• Troubleshooting Guide	20
• Maintenance	21
• Conditions	22
• Limited Warranty	23



PristineHydro™

WATER REVIVAL SYSTEM

PURCHASE RECORDS

Please fill out the following information at the time of installation.

SAVE FOR FUTURE REFERENCE

MODEL: WRS-UC5

PURCHASE DATE:

INSTALL DATE:

SOLD BY:

INSTALLED BY:

SERVICE CENTER PHONE NUMBER:



PristineHydro™

WATER REVIVAL SYSTEM

INTRODUCTION

Congratulations on your purchase of a **PristineHydro™ WATER REVIVAL SYSTEM**. When properly maintained, this system will provide you with years of trouble-free operation. The next sections contain important information on the proper care and maintenance of your system. Please take the time to read through this information carefully.

The cartridges in this system must only be replaced with **PristineHydro Authorized Replacement Filters** and on a regular basis in order to maintain system efficiency and to ensure water production that is 100% free of all undesirable acids and contaminants. These cartridges are designed to work together as a system and should be replaced at the recommended intervals. Any significant change in performance of the system should be investigated promptly to avoid secondary damage or deterioration to other parts of the system.

CAUTION: Improperly installed systems could result in water damage due to leaks and/or flooding. Proper installation of this system requires proficiency with standard sink plumbing and proper use of hand and power tools. Unless you possess plumbing skills, we recommend you consult a licensed professional plumber or contractor.

NOTE:

This system has been designed to be installed by a licensed professional plumber or contractor.



PristineHydro™

WATER REVIVAL SYSTEM

COMPONENT LIST

Your new **WATER REVIVAL SYSTEM** should include the following items. If any items are missing, please contact your supplier, retailer or any local professional plumbing service.

Please take a few moments to check all the following components:

- **Water Revival System Assembly**
- **Water Storage Tank**
- **Tank Valve**
- **Angle Stop Valve**
- **Drain Saddle Valve**
- **Faucet Package**
- **Faucet Connector**
- **Filter Housing Wrench**
- **Color Poly Tubing Set (BLACK, BLUE, RED, WHITE)**
- **Bracket Mounting Screws**
- **TDS Meter**
- **Poly Tubing Cutter**
- **Teflon Tape**
- **(2) Extra Replacement Elbows (PP220808W)**

Recommended Tool List

Before you begin, make sure the installation kit and tools are complete and ready to use.

- **Phillips Screwdriver**
- **Drill and Drill Bits**
- **Wrench or Adjustable Wrench**



PristineHydro™

WATER REVIVAL SYSTEM

DIAGRAM

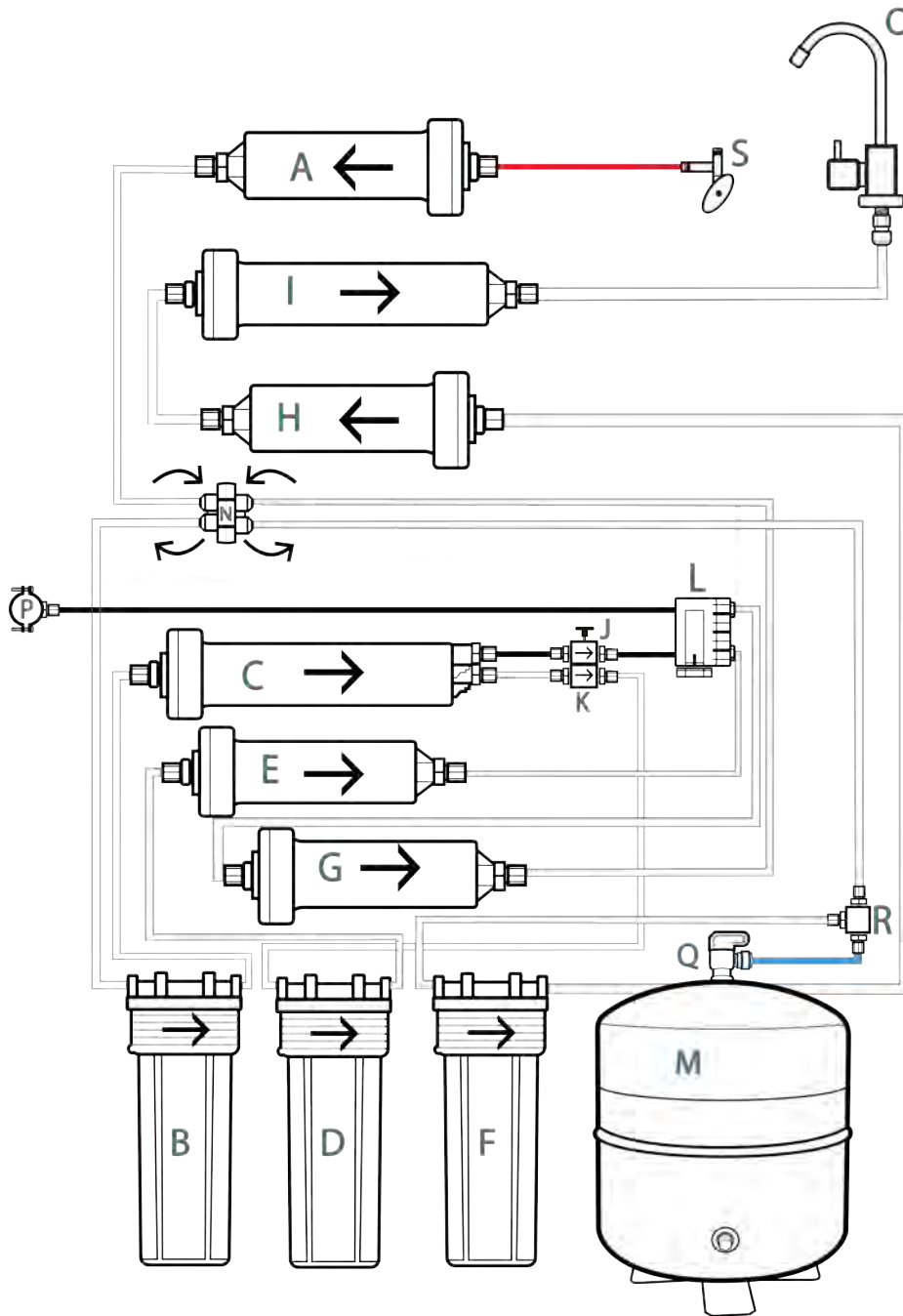

- A. 5 Micron Sediment
- B. KDF + Carbon
- C. High Efficiency Reverse Osmosis Membrane
- D. Primary Deionization
- E. Secondary Deionization
- F. Remineralization
- G. Remineralization
- H. Restructuring + Recharging
- I. Post Granular Polishing Filter
- J. Flow Restrictor
- K. Check Valve
- L. Permeate Pump
- M. Water Storage Tank
- N. Auto Shot-Off Valve
- O. Faucet
- P. Drain Saddle Valve
- Q. Tank Valve
- R. Union Tee
- S. Angle Stop Valve

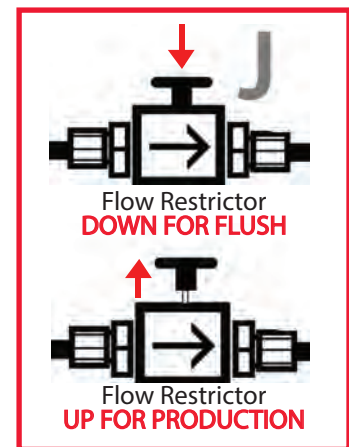

PristineHydro™

WATER REVIVAL SYSTEM

SPECIFICATIONS

SYSTEM PERFORMANCE

Daily Production Rate..... 75 GPD Rated Membrane

FEED WATER REQUIREMENTS

Feed Water Potable, municipal, well water
Feed Pressure 70 to 80 PSI
Feed Temperature 45 Deg. F. to 100 Deg. F.
Total Dissolved Solids 600 PPM or less
Chlorine <1.0 mg/l max
pH 4-8
Turbidity <1.0 NTU (visibly clear)
SDI <5
Iron 0.2 mg/l or less
Manganese 0.03 mg/l or less

**If any of the parameters are exceeded, please contact the supplier.
Pre-treatment or special adjustments may be required.**



PristineHydro™

WATER REVIVAL SYSTEM

QUICK CONNECT GUIDE

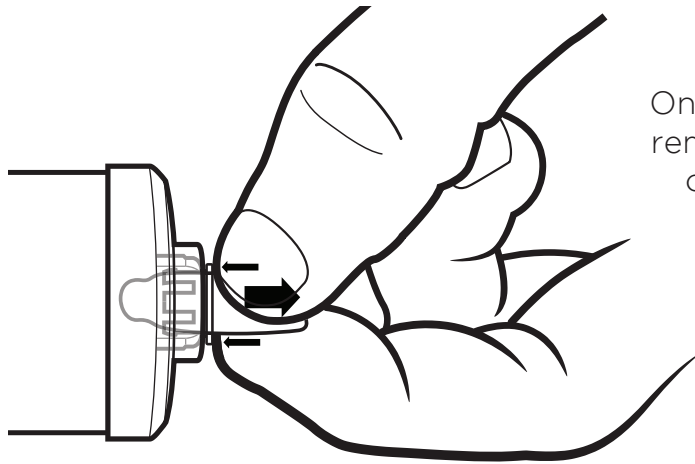

On new filters, be sure to remove plugs from quick connect fittings before attaching tubing.

Push in the collet while simultaneously pulling out the plug.

TO ATTACH TUBING

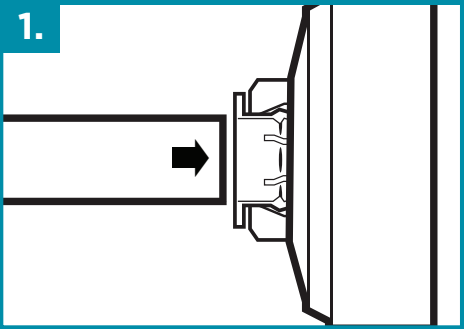

Push tubing straight in as far as it will go.

TO RELEASE TUBING

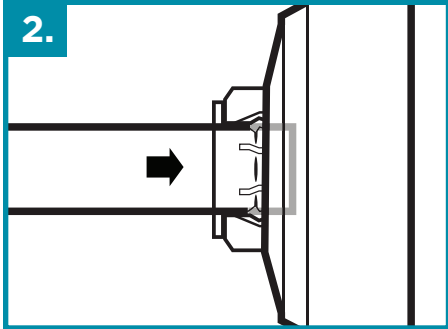

Tubing is secured in position.

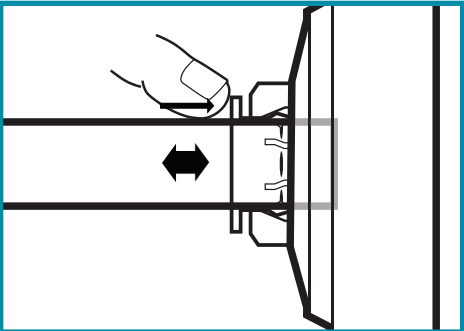

Push in collet while simultaneously pulling on tubing.



WATER REVIVAL SYSTEM

INSTALLATION

STEP 1: Angle Stop Valve

NOTE: These installation instructions are prepared for use by a licensed plumber or contractor.

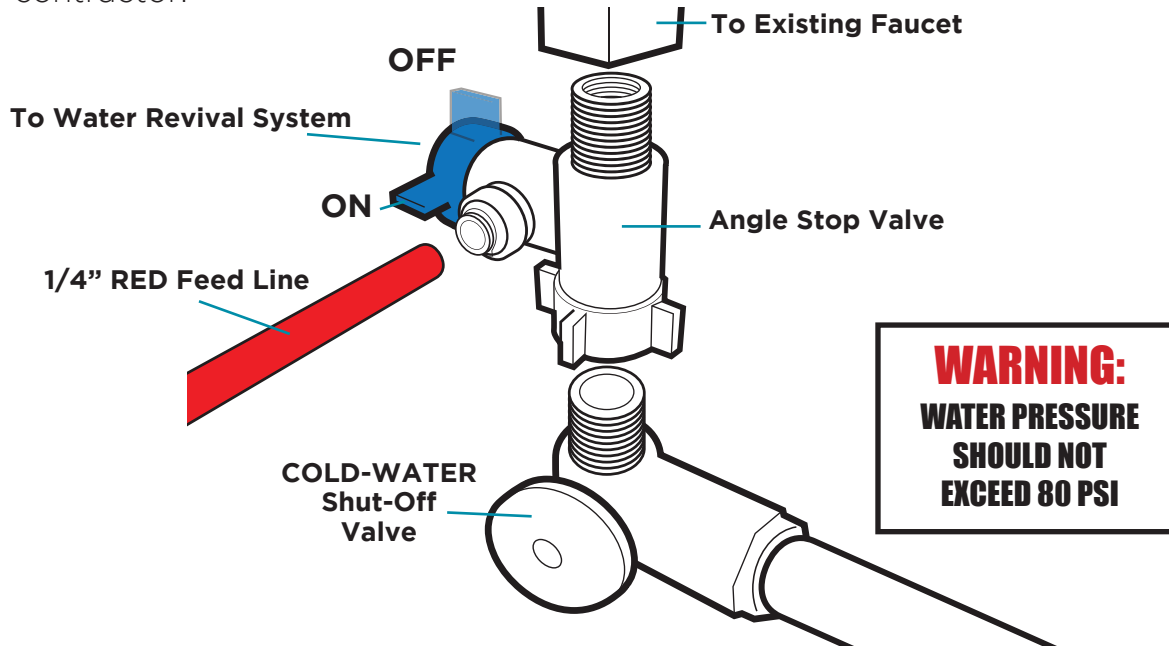

1. Locate the COLD-WATER Shut-Off Valve underneath the sink and turn it OFF.
2. OPEN the COLD-WATER faucet to release the pressure.
3. On the COLD-WATER fitting to the sink, disconnect the flex line from the stand pipe.
4. For traditional piping, an Angle Stop Valve has been supplied. This adapter can be used for both 3/8" or 1/2" feed line plumbing. Simply switch the adapter nut one side of the adapter valve to the other.
5. Thread the female portion of the Angle Stop Valve on to the Cold-Water Shut-Off Valve and re-connect the flex lines to the male threads. If your plumbing is different, connect to the COLD-WATER line with a Saddle Valve or another Valve that is applicable.



STEP 2: Drain Saddle Valve

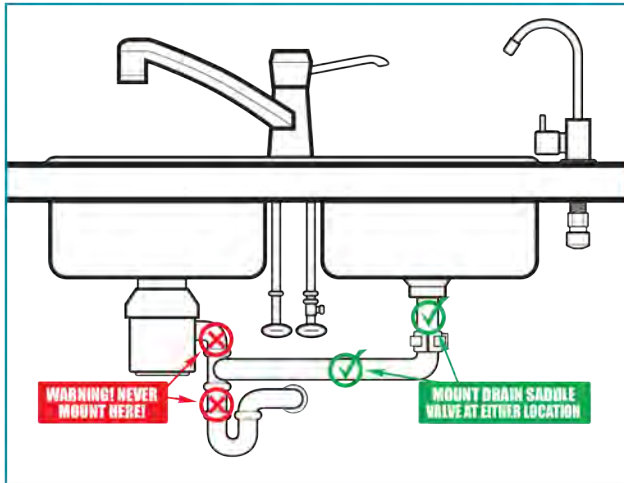

NOTE: To avoid drainage noise, mount drain line as low as possible on the vertical tailpiece, or on horizontal tailpiece.

If existing conditions are favorable, the included Drain Saddle Valve can be used to connect the 1/4" **BLACK** Brine Out Line to an existing drain pipe. It is designed to fit around a standard 1 1/2" OD drain pipe. The Drain Saddle Valve should always be installed before the p-trap. Never mount near the garbage disposal to avoid clogging the drain line with debris.

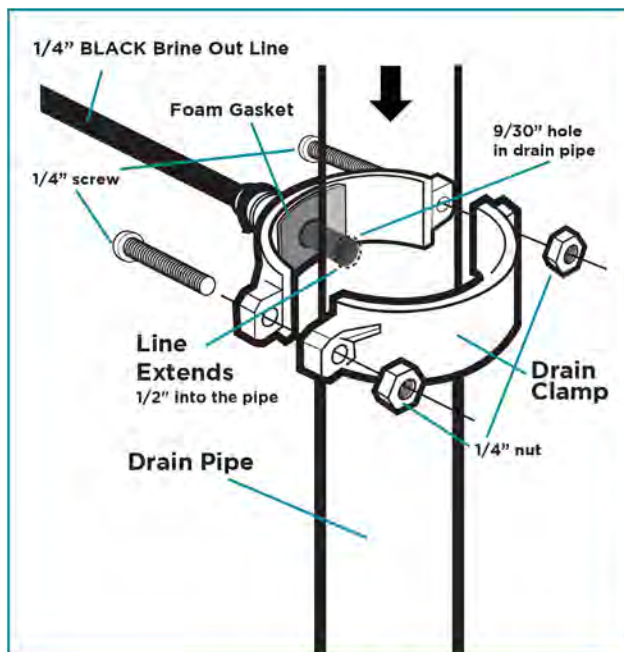

1. Position the Drain Saddle Valve at selected location and mark the opening.

2. Drill 9/30" hole at mark through one side of pipe.

3. Remove backing from foam gasket and place adhesive side to the fitting half of drain clamp around hole.

4. With the **BLACK** line installed 1/2" into the pipe, position both valves of the Drain Saddle Valve on Drain Pipe so the line fits inside.

5. Secure Drain Clamp with bolts and nuts provided. Do not over tighten. Make sure there is equal space between the Drain Clamp on each side.

ATTENTION! Single compartment sinks with garbage disposal may require an alternative drain adapter. See website for available options.

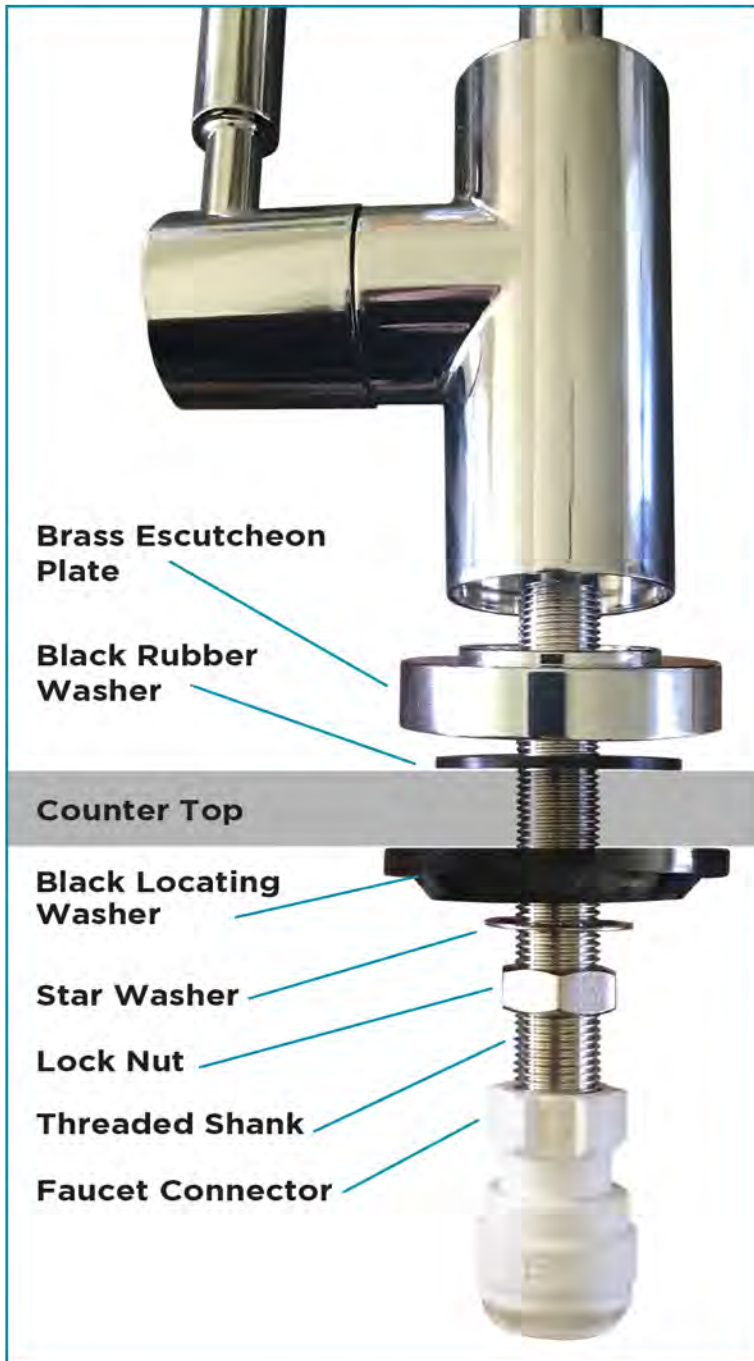
STEP 3: Faucet

The Faucet may be installed on any flat surface. Check the underside of the location for interference. You may use an existing hole on the sink or drill a new hole.

1. Determine the desired location for the Faucet.
2. Make a 1/2" diameter hole using the appropriate tools for the existing materials.
3. On top of the sink, insert the Brass Escutcheon Plate and the Black Rubber Washer in that order over the Threaded Shank.
4. Under the sink, install the Black Locating Washer and the Star Washer over the Threaded Shank. Screw on the Lock Nut and tighten.
5. Thread the Faucet Connector to the end of the Threaded Shank. Make sure it is tight but do not over tighten.

STEP 4: Water Storage Tank



NOTE: The pre-charge on the Water Storage Tank is set at 7-10 psi by the manufacture. If the air pressure is low, remove the blue cap to expose the schrader valve. On an empty tank, add air using a standard floor pump.

1. Open the box and remove the stand from the top of the Water Storage Tank.
2. Wrap the stainless-steel water connection 6-8 times with plumbers (Teflon) tape only.
3. Thread the Tank Valve onto the stainless-steel water connection. Make sure it is tight but do not over-tighten.

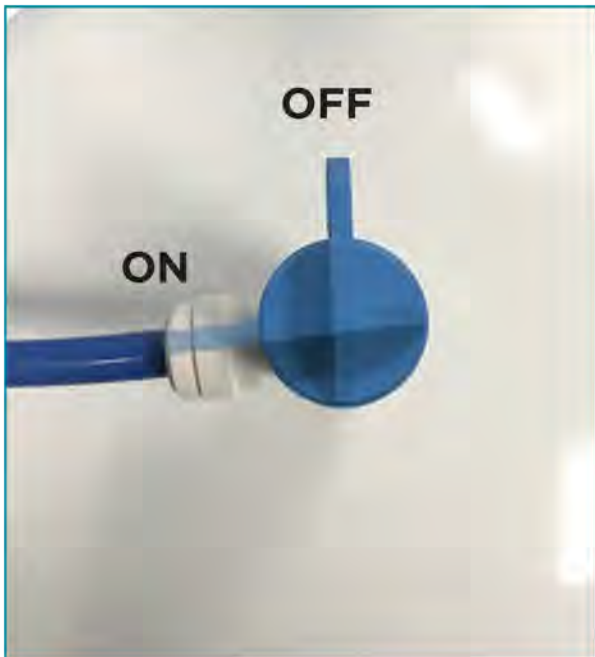

WATER REVIVAL SYSTEM

INSTALLATION

STEP 5: Component Placement

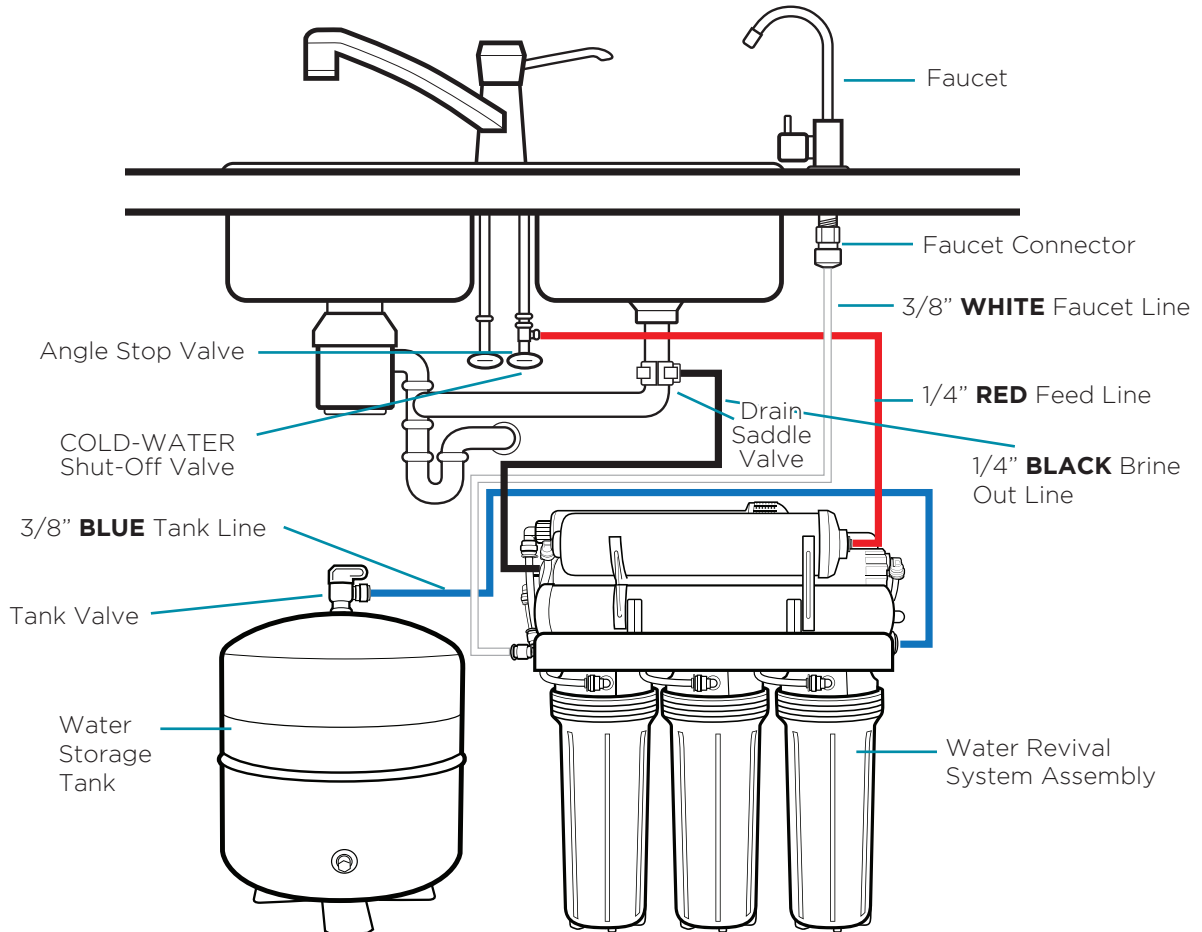

LOCATION: Though most often thought of as an under the kitchen sink counter device, locating the system in a basement, laundry room, or garage may also be convenient, depending on your circumstances.

PLACEMENT: The system should not be further than 10 feet from a drain. Hang the Water Revival System Assembly on a wall or cabinet side wall using the holes in the back of the bracket. Leave at least 3" clearance below the system so that filter cartridges can be easily replaced.

1. Mount the system to a wall or cabinet side wall using the provided hardware.
2. Place the Water Storage Tank in desired location. Since the tank is pressurized, it can stand up vertical or lie down horizontal with the provided base.



WATER REVIVAL SYSTEM

SYSTEM CONNECTIONS

FIG A



FIG B



1. Connect the 1/4" **RED** tube to the 5 Micron **(A)** and the Angle Stop Valve **(B)**.

FIG C



FIG D



2. Connect the 1/4" **BLACK** tube from the Permeate Pump Brine Out **(C)** to the Drain Saddle Valve **(D)**.



PristineHydro™

WATER REVIVAL SYSTEM

SYSTEM CONNECTIONS

FIG E



FIG F



3. Connect the 3/8" **WHITE** tube to the RIGHT SYSTEM PORT **(E)** and the Faucet Connector **(F)**.

FIG G



FIG H



4. Connect the 3/8" **BLUE** tube to the RIGHT SYSTEM PORT **(G)** and the Tank Valve **(H)**.



WATER REVIVAL SYSTEM

START-UP

1. CLOSE the Tank Valve and OPEN the Angle Stop Valve. If any leaks are noted, CLOSE the Angle Stop Valve and correct before proceeding.
2. OPEN the Faucet. After 5 minutes, water will slowly begin to drip out of the Faucet. This will flush out the dust, debris, air and odor from the system.
3. Check system for leaks; tighten when necessary.
4. If possible, use a flashlight to view down the drain to make sure the system is producing waste (brine) water. You should hear the sound of water going down the drain pipe as well as a “clicking” sound from the Permeate Pump.
5. Once the filters have been flushed, CLOSE the Faucet and OPEN the Tank Valve.
6. The Water Storage Tank will fill and the Permeate Pump will automatically shut off in about 1-2 hours, depending on the incoming water pressure.
7. Open the Faucet and drain the Water Storage Tank.

DO NOT DRINK THE WATER FROM THE SYSTEM YET.

8. Water flow will change to dripping depending on your water pressure. Upon complete discharge of the Water Storage Tank, turn handle to CLOSED position on the Faucet and let the refilling process begin.

★★★ REPEAT STEPS 6 & 7 A TOTAL OF THREE TIMES ★★★

9. After the third tank is filled, you may drink the water.

WATER QUALITY CHECK: Your system includes a handheld TDS (total dissolved solids) meter to monitor and maintain the water quality. After the break in period, average TDS readings should be 20-60 ppm. Ranges vary because the chemistry varies with different water sources.

**CHECK FOR LEAKS DAILY DURING THE FIRST WEEK
OF USE AND PERIODICALLY THEREAFTER.**



PristineHydro™

WATER REVIVAL SYSTEM

FILTER REPLACEMENT SCHEDULE

STAGE	DESCRIPTION	AVERAGE SERVICE LIFE	DATE	DATE	DATE	DATE	DATE	DATE	DATE
1	5 Micron	12 Months							
2	KDF + Carbon	12 Months							
3	High Efficiency Reverse Osmosis Membrane	24 Months							
4	Primary Deionization	24 Months							
5	Secondary Deionization	24 Months							
6	Remineralization	24 Months							
7	Remineralization	24 Months							
8	Restructuring + Recharging	N/A							
9	Post Granular Polishing Filter	12 Months							



NOTE: Most customers prefer to replace filters pro-actively in order to maintain PristineHydro™ water quality standards rather than wait for complete filter component degradation. Average Service Life is based on “normal” usage and average feed water quality. Actual filter life will vary with frequency of use, total volume produced, and most importantly, source water quality. If you are a heavy user or your water supply is of below average quality, you may need to replace filters more frequently. We highly recommend periodically checking your system’s output water TDS and replacing filters regularly in order to maintain high system performance.



WATER REVIVAL SYSTEM

FILTER REPLACEMENT PROCEDURE

NOTE: While performing filter changes it is recommended to have a towel handy to dry up any residual water that may leak out from the system.

SYSTEM PREPARATION (pre-service check)

1. Turn OFF Angle Stop Valve.
2. Turn OFF Tank Valve.
3. Open Faucet to relieve pressure.

CARTRIDGE REPLACEMENT

1. Using the supplied Filter Housing Wrench remove the filter housing.
2. Discard old cartridge
3. Install new cartridge in system taking note of the direction of flow.

INLINE FILTER REPLACEMENT

1. Remove tubing from the filter you wish to replace; push in the collet on the quick connect fitting while simultaneously pulling on the tubing. (See pg 9)
2. Replace the filter with the new unit taking note of the direction of flow.
3. Fully insert tubing back into fitting until it hits the internal stop.
4. Give the tube a gentle tug to ensure proper connection.

SYSTEM FLUSH (post-service check)

1. Turn ON Angle Stop Valve
2. If any leaks are noted, CLOSE the Angle Stop Valve and correct before proceeding.
3. Water will slowly begin to drip out of the system Faucet. This will flush out the system.
4. Once the filters have been flushed for an hour, CLOSE the Faucet and OPEN the Tank Valve.
5. The Water Storage Tank will fill and automatically shut off in about 1-2 hours, depending on the incoming water pressure.

MEMBRANE REPLACEMENT

1. Identify and remove the membrane housing from the filter bracket for easier service.
2. Follow the above method for removing the tubing.
3. Unthread the cap from the membrane housing. If overtightened, use a strap wrench for extra leverage.
4. Remove membrane using a pair of pliers.
5. Clean membrane housing with brush.
6. When installing the new membrane, be sure to push the membrane into the housing as far as it will go.

**CHECK FOR LEAKS DAILY DURING THE FIRST WEEK
OF USE AND PERIODICALLY THEREAFTER.**



PristineHydro™

WATER REVIVAL SYSTEM

TROUBLESHOOTING

NOTE: Turn OFF the SYSTEM before servicing or inspecting.

PROBLEM	CAUSE	SOLUTIONS
Milky colored water	- Air in the system	* Air in the system is a normal occurrence with initial startup of system. This milky look will disappear during normal use within 1 to 2 weeks
Fishy smell	- New filters	* Slight odor is a normal occurrence with initial startup of system. OPEN Faucet to flush the system.
Noises from system	- Permeate Pump - Flush/Flow Valve	* While the system is making water the Permeate Pump will make a clicking sound. * High inlet pressure can create hissing sound as water passes through the flow restrictor.
Slow stream from Faucet	- System just starting up - Air pressure in the Water Storage Tank is low	* Normally it takes 1-2 hours to fill the Water Storage Tank. Low water pressure and/or temperature can reduce production rate. * Add pressure to the Water Storage Tank. The pressure should be 7-10 psi when the tank is completely empty.
No water or slow production from Faucet	- Low water pressure - Crimps in tubing - Clogged pre-filters - Fouled High Efficiency Reverse Osmosis Membrane - New System - Angle Stop Valve CLOSED - Tank Valve CLOSED	* Add a booster pump. * Make sure all tubing is straight. * Replace pre-filters. * Replace High Efficiency Reverse Osmosis Membrane. * Wait at least 5 minutes for water to travel through System to Faucet. * OPEN Angle Stop Valve. * OPEN Tank Valve and allow Water Storage Tank to fill to maximum capacity.
Unusual taste or smell	- Coconut Carbon is depleted - Fouled High Efficiency Reverse Osmosis Membrane - Fouled Deionization Cartridge	* Replace Remineralization + Coconut Carbon Cartridge. * Replace High Efficiency Reverse Osmosis Membrane. * Replace Deionization Cartridges.
No drain water	- Clogged Auto Shut-Off Valve - Clogged Filter(s)	* Replace Auto Shut-Off Valve. * Replace Filter(s).
Leaks*	- Fittings are not tightened - Loose tubing - Damaged O-Ring	* Tighten fittings as necessary. * Make sure tubing is fully seated in fittings. * Replace the O-Ring.

***LEAKS SHOULD BE TAKEN SERIOUSLY IN ORDER TO PREVENT WATER DAMAGE.**



PristineHydro™

WATER REVIVAL SYSTEM

MAINTENANCE

Every month or so, it is recommended to flush the High Efficiency Reverse Osmosis Membrane in order to maintain system performance.

1. CLOSE the Tank Valve.

2. OPEN the Faucet to relieve system pressure.

3. Hold DOWN the black button on the Flush/Flow Valve.

4. More brine (waste) water will now flow from the High Efficiency Reverse Osmosis Membrane through the 1/4" **BLACK** Line and down the drain. This helps flush deposits and significantly increases the usable life of the High Efficiency Reverse Osmosis Membrane.

5. After 2 to 3 minutes, release the black button on the Flush/Flow Valve.

6. CLOSE the Faucet and OPEN the Tank Valve in order to return the system to normal operation.

WATER QUALITY CHECK:

Your system includes a handheld TDS (total dissolved solids) meter to monitor and maintain the water quality. After the break in period, average TDS readings should be 40-80 ppm.

Ranges vary because the chemistry varies with different water sources.

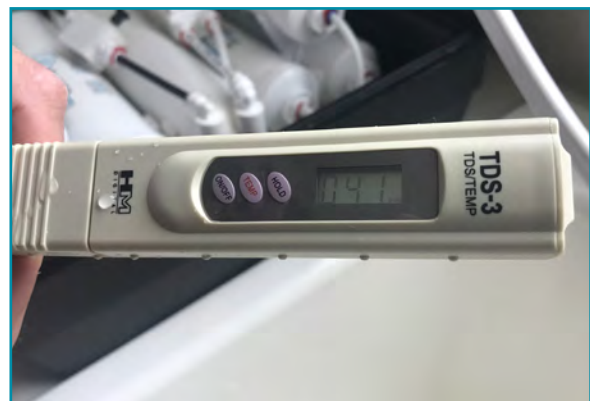

PristineHydro™

WATER REVIVAL SYSTEM

CONDITIONS

IMPORTANT - READ THIS FIRST

Please pay attention to the following installation and safety instructions/recommendations:

- Read the installation manual before installing this system.
- Install the system at a location with adequate drainage.
- This water system is for INDOOR use ONLY. To preserve the unit, avoid using excessive water temperatures (HOT or COLD) and protect against sudden temperature changes.
- The system is designed to be installed by and/or under supervision of a professional, licensed installer or plumber.
- Inspect all connections after the installation to make sure NO LEAKS occur.
- Wait and inspect the system AFTER its pressurized.
- MUST install a Pressure Regulator on the system when your water main pressure is over 80 psi.
- Strongly recommended: SHUT OFF the water supply when homeowner/user will not be using the water system for a long period of time.

IMPORTANT

Please contact your insurance carrier before installing your Water Revival System. PristineHydro WILL NOT be responsible for ANY water damage of any kind under any circumstances.

These are our recommendations to avoid water damage.

- Install a PRESSURE REGULATOR/PRESSURE LIMITING VALVE and LEAK DETECTOR SHUTOFF DEVICE to avoid water damage.
- Homeowner/User must properly maintain the water system and replace filters at regular intervals.

ALL O-RINGS SEALS, FITTINGS, FILTER CANISTERS, AND WATER SEAL TAPE WEAR OUT AFTER CERTAIN PERIODS OF TIME. THE LIFETIME OF THESE COMPONENTS ARE SUBJECT TO DIFFERENCES IN WATER QUALITY. THEREFORE, ADEQUATE MAINTENANCE IS NECESSARY AND MANDATORY.

- Please contact a professional, licensed installer or plumber who can implement the above requirements. Our warranty covers replacement or repair of the purchased system only; NO guarantee, warrantee, or other coverage is provided with respect to any damage or loss to property as a result of installation and usage of this product. Please consult with your own insurance carrier for such coverage if desired.

PRODUCT WARRANTY

For further details, please refer to supplier's terms and conditions of sales.

WARNING

DO NOT INSTALL THE SYSTEM WHERE THE WATER IS MICROBIOLOGICALLY UNSAFE OR OF UNKNOWN QUALITY. ADEQUATE DISINFECTION IS REQUIRED BEFORE OR AFTER THE SYSTEM.



PristineHydro™

WATER REVIVAL SYSTEM

LIMITED WARRANTY

All components except the element(s) are warranted to be free of defects in materials or workmanship for a period of one (1) year from the date of purchase. This limited warranty excludes damage resulting from improper care of handling, accidents, modification, unauthorized repairs, normal wear or other causes which are not defects in materials or workmanship.

If there is a covered defect, **PristineHydro™** will repair or replace the product free of charge or issue a refund at its sole discretion. The product is provided "AS IS AND WITH ALL FAULTS," and **PristineHydro** hereby disclaims all other warranties and/or conditions arising out of the use of the product.

PristineHydro shall determine coverage under this warranty only after physical inspection and verification of the unit/defect(s) by **PristineHydro**. Shipping costs for the return of defective systems to **PristineHydro** shall be at the purchaser's expense. **PristineHydro** will ship repaired or replacement systems or parts at **PristineHydro's** expense.

Elements have a one-year pro-rata warranty. If it is established that the element problem is related to material and or workmanship, then the elements will be replaced at no charge in the first month after the date of purchase. A cost of 8 1/3% per month will be charged for each month after the first month. Improper system operation, excessive water temperature (above 100 Deg. F.), failure to prevent chlorine passage into the system, scaling due to water softener or chemical feed operational negligence and general system neglect voids the element warranty.

This warranty covers the cost of materials only. Any labor charges are paid by the system owner. We do not warrant any system or part of a system that has been damaged by neglect, intentional or negligent or improper use, act of nature, fire or vandalism.

PristineHydro™ assumes no warranty liability with respect to defects in any product caused by:

- Customer's unauthorized modification of the product;
- Customer's unauthorized attempt to repair the product;
- Customer's negligent, accidental, or other improper use of the product;
- Customer's installation, operation, or maintenance of the product other than in a manner described in the instruction manual, if applicable;
- Customer's combination of the product with product(s) not supplied by PristineHydro.



PristineHydro™

WATER REVIVAL SYSTEM

LIMITED WARRANTY

CORRECTION OF DEFECTS BY REPAIR OR REPLACEMENT SHALL CONSTITUTE THE EXCLUSIVE SOLE REMEDY FOR A BREACH OF THIS LIMITED WARRANTY, AND PRISTINEHYDRO WILL NOT BE LIABLE FOR ANY CONSEQUENTIAL DAMAGES, PROPERTY LOSS OR PERSONAL INJURY OR FOR ANY OTHER LOSSES, DAMAGES, OR EXPENSES DIRECTLY OR INDIRECTLY RESULTING FROM THE INSTALLATION OR USE OF PRODUCT, INCLUDING, BUT NOT LIMITED TO WATER DAMAGE. PLEASE CONSULT WITH YOUR OWN INSURANCE CARRIER FOR SUCH COVERAGE IF DESIRED. THE ABOVE WARRANTY SUPERSEDES AND IS IN LIEU OF ALL OTHER WARRANTIES, EXPRESS OR IMPLIED, AND ALL OTHER OBLIGATIONS OR LIABILITIES OF PRISTINEHYDRO, INCLUDING ANY IMPLIED WARRANTIES OF MERCHANTABILITY AND FITNESS FOR A PARTICULAR PURPOSE. NO AGENT DISTRIBUTOR, RETAILER, OR OTHER PARTY IS AUTHORIZED TO MAKE ANY WARRANTIES ON BEHALF OF PRISTINEHYDRO OR TO ASSUME FOR PRISTINEHYDRO ANY OTHER LIABILITY IN CONNECTION WITH ANY PRISTINEHYDRO PRODUCT.

The construction, validity, and performance of this agreement between PristineHydro and customer (purchaser and/or owner of the product) shall be governed by the laws of the State of California, United States of America, without reference to its choice of law rules. Customer expressly submits and consents to the jurisdiction and venue of the State or Federal courts located in Orange County, California, for the trial of any lawsuit arising out of the contract for sale. Any action for the breach of the contract for sale must be commenced within one (1) year after the cause of action has accrued.

FORCE MAJEURE - PristineHydro shall not be liable for any default or delay attributable to any cause, circumstance, or contingency beyond its control or the control of its suppliers or manufacturers which prevents or impedes manufacture, supply, or delivery by PristineHydro. Such causes, circumstances, and contingencies shall include, but not be limited to: acts of God; governmental acts, decrees or restrictions; accidents; wars, riots, or civil commotion; fire; strikes, lockouts, or other labor problems; restraints affecting shipment or credit; non arrival or delay of carriers; inadequate or reduced supply or excessive cost of suitable raw materials, transportation or production facilities; and any other causes, circumstances, or contingencies affecting PristineHydro, its suppliers, or manufacturers as to manufacture, supply, or delivery. In the event of such default



PristineHydro™

WATER REVIVAL SYSTEM

LIMITED WARRANTY

or delay, the date for shipment shall be extended correspondingly. PristineHydro may make delivery on an equitable basis with reference to all its customers.

For service assistance or resolution of a service problem,
or for product information or operation, please visit:

WWW.LIVEPRISTINE.COM



PristineHydro™