

Integral

Owner's Manual



Model: Front Load Cargo Tricycle
Brand: Integral Electrics
Manual Version: 1.0
Release date: 03/25/2023

If you need to reach Integral Electrics for any reason, you can do it using the following contact information:

Phone: +1 510-224-4706
e-mail: hello@integralelectrics.com

Contents

1. INTRODUCTION	4		
1.1 General Warning	4		
1.2 An Important Note on Tipping and Loss of Control	6		
2. FIRST	8		
2.1 Box Contents	8		
2.2 Bike Fit	9		
2.3 Safety First	9		
2.4 Mechanical Safety Check	10		
2.4.1 Nuts, Bolts Screws & Other Fasteners	10		
2.4.2 Tires & Wheels	11		
2.4.3 Brakes	11		
2.4.4 Wheel Retention System	11		
2.4.5 Seat Post	12		
2.4.6 Saddle Alignment	12		
2.4.7 Handlebar	12		
2.5 First Ride	12		
3. SAFETY	13		
3.1 The Basics	13		
3.2 Riding Safety	14		
3.3 Off Road Safety	15		
3.4 Off Road Respect	16		
3.5 Wet Weather Riding	16		
3.6 Night Riding	17		
3.7 Extreme, Stunt Or Competition Riding	18		
3.8 Changing Components Or Adding Accessories	19		
4. FIT	20		
4.1 Stand Over Height	20		
4.2 Saddle Position	20		
4.2.1 Up and Down Adjustment	20		
4.2.2 Front and Back Adjustment	21		
4.2.3 Saddle Angle Adjustment	22		
4.3 Handlebar Height And Angle	23		
4.4 Control Position Adjustments	23		
4.5 Brake Reach	23		
5. TECH	24		
5.1 Wheels	24		
5.1.1 Front Wheels	24		
5.1.2 Rear Wheel	25		
5.1.3 Removing & Installing The Front Wheels	26		
5.1.4 Removing And Installing The Rear Wheel	27		
5.2 Seat Post Cam Action Clamp	28		
5.2.1 Adjusting The Seat Post Cam Action Mechanism	29		
5.3 Brakes	29		
5.3.1 Brake Controls And Features	30		
5.3.2 How Brakes Work	30		
5.4 Shifting Gears	32		
5.4.1 Shifting The Rear Derailleur	32		
		5.4.2 Which Gear Should I Be In?	33
		5.5 Pedals	34
		5.5.1 Removing And Installing The Pedals	34
		5.5.2 Toe Overlap	35
		5.6 Tires And Tubes	35
		5.6.1 Tires	35
		5.6.2 Tubeless Rims And Tires	37
		5.6.3 Tire And Rim Width/Diameter	37
		5.6.4 Tire Clearance	38
		5.6.5 Tire Valves	39
		6. ELECTRIC BIKES	40
		6.1 Knowing Your Bike	40
		6.1.1 Motor	41
		6.1.2 Li-Ion Battery	41
		6.1.3 Pedal Sensor	41
		6.1.4 Display And Throttle	42
		6.1.5 Charger	42
		6.2 Using Your Bike	42
		6.2.1 Display Controls	43
		6.2.2 Battery Controls	44
		6.3 Battery Care And Safety	46
		6.3.1 Initial Actions	46
		6.3.2 Battery Charging	46
		6.3.3 Charger FCC Information	47
		6.3.4 Battery Storage	48
		6.3.5 Battery Shipping And Transport	48
		6.3.6 Battery Disposal	48
		6.3.7 Additional Battery Remarks	48
		6.3.8 Battery Warnings	49
		6.4 Riding An Electric Bike	50
		6.4.1 Safety	50
		6.4.2 Legality	51
		6.4.3 Range	51
		6.4.4 Hills	52
		6.5 Electric Bike Care	53
		6.6 Electric bike service	53
		7. CARGO	54
		7.1 The Front Box	54
		7.1.1 Passengers And Children	55
		7.2 Additional Cargo Considerations	56
		7.2.1 Pre-Ride Checklist	57
		7.2.2 Kickstand and Parking Brake	57
		7.2.3 Maximum Payloads	57
		8. SERVICE	58
		8.1 Service Intervals	58
		8.1.1 Break-In Period	59
		8.1.2 Before Every Ride	59
		8.1.3 After Every Long Or Hard Ride	59
		8.1.4 Disc Brakes	60

8.1.5 As Required	60
8.1.6 If Your Tricycle Sustains An Impact	61
APPENDIX A: TEACHING YOUR CHILD THE RULES AND MODELING THEM YOURSELF	62
APPENDIX B: INTENDED USE OF YOUR BICYCLE	64
APPENDIX C: THE LIFESPAN OF YOUR BIKE AND ITS COMPONENTS	65
APPENDIX D: FASTENER TORQUE SPECIFICATIONS	70
APPENDIX E: TRICYCLE SPECIFICATIONS	72
APPENDIX F: DISPLAY ERROR CODES	73

1. INTRODUCTION

Congratulations on the purchase of your new electric tricycle, we thank you for your trust. This product has been designed with safety and functionality in mind. We wish you lots of joyful hours riding your new electric tricycle.

To ensure you a safe and convenient use of your new electric tricycle, please completely read these instructions carefully prior to use. This manual describes all the functions of your new tricycle as well as important warnings to make your ride safe.

Throughout this manual, you will see that it is recommended to contact your dealer for many items. You can always contact Integral Electrics for parts, advice, and information, however we cannot conduct physical assembly, maintenance or repair. Where physical in person maintenance or repair is required, this can be done by any trained bicycle technician in your area.

IMPORTANT



- a. This manual contains important safety, performance and service information. Read it before you take the first ride on your new tricycle, and keep it for future reference.
- b. Your new electric tricycle rides considerably different from a traditional bicycle, please make sure to completely read the section “Cargo” to familiarize yourself with the specifics of riding an electric tricycle.
- c. Additional safety, performance and service information for specific components such as suspension or pedals on your tricycle, or for accessories such as helmets or lights that you purchase, may also be available. Make sure that your dealer has given you all the manufacturers’ literature that was included with your tricycle or accessories. In case of a conflict between the instructions in this manual and information provided by a component manufacturer, always follow the component manufacturer’s instructions.

NOTE: This manual is not intended as a comprehensive use, service, repair or maintenance manual. Please see your dealer for all service, repairs or maintenance. Your dealer may also be able to refer you to classes, clinics or books on tricycle use, service, repair or maintenance.

1.1 General Warning

Like any sport, bicycling involves risk of injury and damage. By choosing to ride a tricycle, you assume the responsibility for that risk, so you need to know — and to practice — the rules of safe and responsible riding and of proper use and maintenance. Proper use and maintenance of your tricycle reduces risk of injury.

This Manual contains many “Warnings” and “Cautions” concerning the consequences of failure to maintain or inspect your tricycle and of failure to follow safe cycling practices.

- a. The combination of the  safety alert symbol and the word **WARNING** indicates a potentially hazardous situation which, if not avoided, could result in serious injury or death.
- b. The combination of the  safety alert symbol and the word **CAUTION** indicates a potentially hazardous situation which, if not avoided, may result in minor or moderate injury, or is an alert against unsafe practices.
- c. The word **CAUTION** used without the safety alert symbol indicates a situation which, if not avoided, could result in serious damage to the tricycle or the voiding of your warranty.

Many of the Warnings and Cautions say, “You may lose control and fall”. Because any fall can result in serious injury or even death, we do not always repeat the warning of possible injury or death.

Because it is impossible to anticipate every situation or condition that can occur while riding, this manual makes no representation about the safe use of the tricycle under all conditions. There are risks associated with the use of any tricycle which cannot be predicted or avoided, and which are the sole responsibility of the rider.

1.2 An Important Note on Tipping and Loss of Control

WARNING: The most common way to incur and injure yourself or a passenger on a tricycle is by losing control and tipping it over. While this is not an exhaustive list, there are five main ways you can lose control of your trike or tip it over.

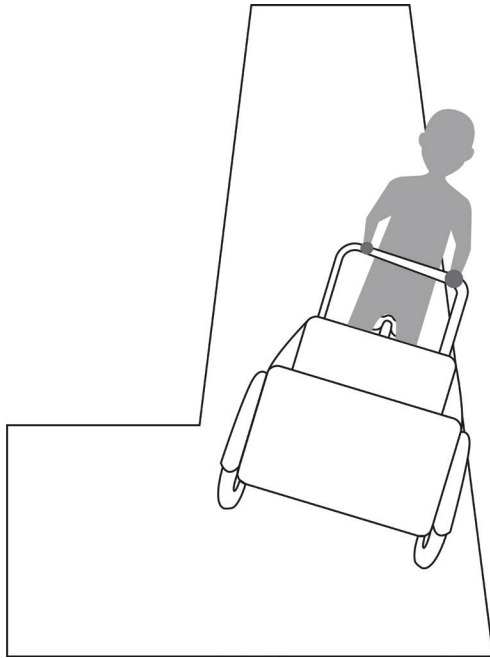

fig. 1

WARNING: Do not go too fast or be in a rush. While the maximum speed of this vehicle is 20 mph, we encourage you not to test this limit. One of the benefits of a cargo tricycle for your busy modern life is that it will allow you to slow down and be fully present with your environment and precious cargo. At times, E-biking may get you to your destination faster because you don't have to circle for parking or get stuck in traffic, **BUT IF YOU ARE IN A RUSH AND CANNOT TRUST YOURSELF TO OPERATE THE TRICYCLE WITH FULL CAUTION AT UNHURRIED SPEEDS, PLEASE LEAVE IT AT HOME.** Especially in the early days of ownership, allow lots of extra time for each trip, go at an unhurried pace, and time how long it takes you to get to your typical destinations. This will allow you to leave with plenty of time so you can drive at a relaxed and cautious pace.

WARNING: Do not take your hands off the steering bar or eyes off the road. Do not reach for your phone, a snack for the kids, or the dog's toy while you are in motion. Please come to a complete stop if you need to accommodate your phone or your passengers.

WARNING: Do not take a sharp turn too fast on flat ground. Your tricycle is equipped with stoppers on the left and right side to prevent you from turning too sharply. However, you alone can control the speed at which you turn. Take turns at 5 mph or less. Even on flat surfaces, turning too sharply at too high a speed can cause tipping. The amount of cargo you are carrying will also impact the weight distribution and speed at which tipping can occur.

WARNING: Do not turn too fast on steep uphill or downhill terrain. If you're going down a steep hill and attempt to turn left or right, the tricycle can easily tip towards the downhill side due to the weight distribution and downhill inertia. For this reason, slow your tricycle almost to a complete stop before making turns on downhill slopes. Even when you are pedaling up a steep hill and going slower, apply the same caution to left and right turns. Any turn on any incline or decline slope that is taken too fast can cause the tricycle to tip towards the down slope side.

WARNING: Avoid using high levels of pedal assist during turns without applying the brakes. Your motor's pedal assist will increase your speed when you are pedaling and not applying the brakes. When you are applying the brakes, the pedal assist is turned off and cannot increase your speed. Given the importance of low speed turns mentioned above, applying the brakes when taking turns in pedal assist mode assures your tricycle maintains a low speed while turning.

1.3 A Special Note For Parents

⚠ WARNING: Your new electric tricycle is designed to be driven exclusively by licensed drivers aged 16 or older. Please do not allow any person or child below 16 years old to drive this electric tricycle as it poses an extremely unsafe situation.

⚠ WARNING: Your new electric tricycle is equipped with a front cargo area suitable for transporting children and goods. Please make sure to read and fully understand the “Cargo” Section of this manual which provides specific information about loading cargo in your tricycle.

As a parent or guardian, you are responsible for the activities and safety of your minor children, and that includes making sure that your children travels safely in your tricycle. It is your responsibility to make sure that the tricycle is in good repair and safe operating condition; that you and your children have learned and understand the safe operation of the tricycle; and that you and your children have learned, understand and obey not only the applicable local motor vehicle, tricycle and traffic laws, but also the common sense rules of safe and responsible bicycling. As a parent, you should read this manual, as well as review its warnings and the tricycle’s functions and operating procedures with your children, before riding with your child in the front cargo area.

⚠ WARNING: Make sure that your child always wears an approved bicycle helmet when riding; but also make sure that your child understands that a bicycle helmet is for bicycling only, and must be removed when not riding. A helmet must not be worn while playing, in play areas, on playground equipment, while climbing trees, or at any time while not riding a tricycle. Failure to follow this warning could result in serious injury or death.

⚠ WARNING: The American Academy of Pediatrics recommends that children under 1 year of age do not ride any kind of bicycle or tricycle. When your child turns 1 year old, ask your pediatrician at your child’s well check to confirm whether he/she has enough neck strength to wear a helmet. Do not attempt to adapt any accessory such as a car seat to your tricycle to transport children under 1 year of age. Failure to follow this warning could result in serious injury or death.

2. FIRST

2.1 Box Contents

Please make sure that you have received all the following items:

1. Electric tricycle
2. Li-Ion battery
3. Battery charger and mains wire
4. Rain cover for cargo area
5. Tool box
6. Manual

If you are missing any of these items, please contact your dealer or reach out directly to Integral Electrics.

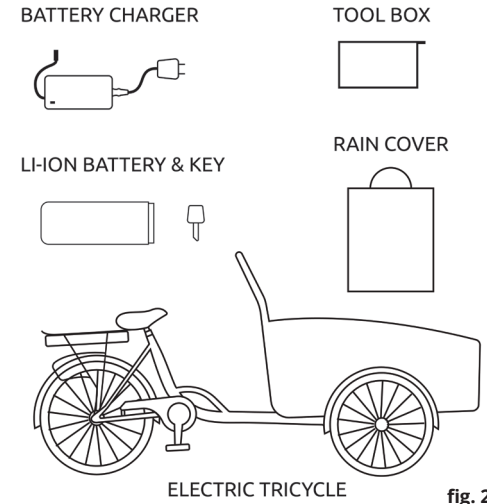

2.2 Bike Fit

1. Is your bike the right size? To check, see Section 4.1 . If your tricycle is too large or too small, you may lose control and fall. If your new bike is not the right size, ask your dealer to exchange it before you ride it.
2. Is the saddle at the right height? To check, see Section 4.2 . If you adjust your saddle height, follow the Minimum Insertion instructions in Section 4.2.1.
3. Are saddle and seat post securely clamped? A correctly tightened saddle will allow no saddle movement in any direction. See Section 4.2.2.
4. Are the stem and handlebars at the right height for you? If not, see Section 4.3.
5. Can you comfortably operate the brakes? If not, you may be able to adjust their angle and reach. See Section 4.5.
6. Do you fully understand how to operate your new tricycle? If not, before your first ride, have your dealer explain any functions or features that you do not understand you do not understand.

2.3 Safety First

1. Always wear an approved helmet when riding your bike, and follow the helmet manufacturer’s instructions for fit, use and care.
2. Do you have all the other required and recommended safety equipment? See Section 3 . It’s your responsibility to familiarize yourself with the laws of the areas where you ride, and to comply with all applicable laws.
3. Do you know how to correctly secure your front and rear wheels? Check Section 5.1 to make sure. Riding with an improperly secured wheel can

cause the wheel to wobble or disengage from the tricycle and cause serious injury or death.

4. On Section 6 additional safety measures pertaining electric tricycles are introduced, please get yourself acquainted with them to safely ride your new electric tricycle.
5. On section 7 specific details pertaining cargo tricycle are introduced, please get yourself acquainted with them to safely ride with children and cargo in your new electric tricycle.

2.4 Mechanical Safety Check

Routinely check the condition of your tricycle before every ride.

2.4.1 Nuts, Bolts Screws & Other Fasteners

A wide variety of fastener sizes and shapes made in a variety of materials are used in your electric tricycle; to make sure that the many fasteners on your tricycle are correctly tightened, refer to the Fastener Torque Specifications in Appendix D of this manual or to the torque specifications in the instructions provided by the manufacturer of the component in question.

Correctly tightening a fastener requires a calibrated torque wrench. A professional bicycle mechanic with a torque wrench should torque the fasteners on you tricycle. If you choose to work on your own tricycle, you must use a torque wrench and the correct tightening torque specifications from the tricycle or component manufacturer or from your dealer. If you need to make an adjustment at home or in the field, we urge you to exercise care, and to have the fasteners you worked on checked by your dealer as soon as possible.

Note that there are some components that require special tools and knowledge. In Sections 4 and 5 we discuss the items that you may be able to adjust yourself. All other adjustments and repairs should be done by a qualified tricycle mechanic.

 **WARNING: Correct tightening force on fasteners – nuts, bolts, screws – on your tricycle is important. Too little force, and the fastener may not hold securely. Too much force, and the fastener can strip threads, stretch, deform, or break. Incorrect tightening force can result in component failure, which can cause you to lose control and fall.**

Make sure nothing is loose. Lift the front wheel off the ground by two or three inches, then let it bounce on the ground. Anything sound, feel or look loose? Do a visual and tactile inspection of the whole bike. Any loose parts or accessories? If so, secure them. If you're not sure, ask someone with experience to check.

2.4.2 Tires & Wheels

Make sure tires are correctly inflated (see Section 5.1). Check by putting one hand on the saddle, one on the intersection of the handlebars and stem, then bouncing your weight on the bike while looking at tire deflection. Compare what you see with how it looks when you know the tires are correctly inflated; and adjust if necessary.

Tires in good shape?

Spin each wheel slowly and look for cuts in the tread and sidewall. Replace damaged tires before riding the bike.

Wheels true?

Spin each wheel and check for brake clearance and side-to-side wobble. If a wheel wobbles side to side even slightly, or rubs against or hits the brake pads, take the bike to a qualified bike shop to have the wheel trued.

 **CAUTION: Wheels must be true for safe riding. Wheel truing is a skill that requires special tools and experience. Do not attempt to true a wheel unless you have the knowledge, experience and tools needed to do the job correctly.**

Wheel rims clean and undamaged?

Make sure the rims are clean and undamaged at the tire bead. Check to make sure that any rim wear indicator marking is not visible at any point on the wheel rim.

 **WARNING: Tricycle wheel rims are subject to wear. Ask your dealer about wheel rim wear. Some wheel rims have a rim wear indicator that becomes visible as the rim's braking surface wears. A visible rim wear indicator on the side of the wheel rim is an indication that the wheel rim has reached its maximum usable life. Riding a wheel that is at the end of its usable life can result in wheel failure, which can cause you to lose control and fall.**

2.4.3 Brakes

Check the brakes for proper operation (see Section 5.3). Squeeze the brake levers. Are the brake quick-releases closed? All control cables seated and securely engaged? Do the brakes begin to engage within an inch of brake lever movement? Can you apply full braking force at the levers without having them touch the handlebar? If not, your brakes need adjustment. Do not ride the bike until the brakes are properly adjusted by a professional tricycle mechanic.

2.4.4 Wheel Retention System

Make sure the front and rear wheels are correctly secured. See Section 5.1 .

2.4.5 Seat Post

Your seat post has an over-center cam action fastener for easy height adjustment, check that it is properly adjusted and in the locked position. See 5.2.

2.4.6 Saddle Alignment

Make sure the saddle is parallel to the bike's center line and clamped tight enough so that you can't twist them out of alignment. See Sections 4.2.

2.4.7 Handlebar

Make sure that the handlebar is inserted into the handlebar supports and firmly fixed so that it doesn't wobble or you are not able to take it out.

Make sure the handlebar grips are secure and in good condition. If your grips are loose, or have cuts, tears or worn out areas, have your dealer replace them.

Your tricycle handlebar is not designed to be compatible with any type of handlebar extensions. If you consider you need to install an extension, please check with your dealer the possibilities, and make sure they are clamped according to the handlebar and extension manufacturer's instructions. Make sure your handlebar, extensions, grips and brake and shifting controls are secure and allow the safe operation of your tricycle, including the ability to steer, brake and shift without any interference.

 **WARNING: A loose handlebar can cause you to lose control, causing a crash resulting in serious injury or death.**

 **WARNING: The ends of handlebars and handlebar extensions must be plugged at all times. Unplugged handlebars or extensions can cut or impale you even in a minor crash, resulting in serious injury or death.**

2.5 First Ride

When you buckle on your helmet and go for your first familiarization ride on your new tricycle, be sure to pick a controlled environment, away from cars, other cyclists, obstacles or other hazards. Ride to become familiar with the controls, features and performance of your new bike.

Familiarize yourself with the braking action of the bike (see Section 5.3). Test the brakes at slow speed, putting your weight toward the rear and gently applying the brakes, rear brake first. Sudden or excessive application of the front brake could cause you to lose control or fall. Applying brakes too hard can lock up a wheel, which could cause you to lose control and fall. Skidding is an example of what can happen when a wheel locks up.

Practice shifting the gears (see Section 5.4). Remember to never move the shifter while pedaling backward, nor pedal backwards immediately after

having moved the shifter. This could jam the chain and cause serious damage to the tricycle.

Check out the handling and response of the bike; and check the comfort. If you have any questions, or if you feel anything about the bike is not as it should be, consult your dealer before you ride again.

3. SAFETY

3.1 The Basics

 **WARNING: The area in which you ride may require specific safety devices. It is your responsibility to familiarize yourself with the laws of the area where you ride and to comply with all applicable laws, including properly equipping yourself and your bike as the law requires.**

Observe all local bicycle laws and regulations. Observe regulations about bicycle lighting, licensing of bicycles, riding on sidewalks, laws regulating bike path and trail use, helmet laws, child carrier laws, special tricycle traffic laws. It's your responsibility to know and obey the laws.

On sections "Electric Bicycle" and "Cargo" additional safety measures pertaining electric tricycles are introduced, please get yourself acquainted with them in order to safely ride your new electric tricycle.

- a. Always wear a cycling helmet (fig. 3) that meets the latest certification standards and is appropriate for the type of riding you do. Always follow the helmet manufacturer's instructions for fit, use and care of your helmet. Most serious bicycle injuries involve head injuries that might have been avoided if the rider had worn an appropriate helmet.



fig.3

-  **WARNING: Failure to wear a helmet when riding may result in serious injury or death.**
- b. Always do the Mechanical Safety Check (Section 2.4) before you get on a bike.
- c. Be thoroughly familiar with the controls of your tricycle: brakes (Section 5.3), pedals (Section 5.4), shifting (Section 5.5), and electric controls (Section 6.2)
- d. Be careful to keep body parts and other objects away from the sharp teeth of chainrings, the moving chain, the turning pedals and cranks, and the spinning wheels of your tricycle.
- e. Always wear:
 - a. Shoes that will stay on your feet and will grip the pedals. Make sure that shoelaces cannot get into moving parts, and never ride barefoot or in sandals.
 - b. Bright, visible clothing that is not so loose that it can be tangled in the tricycle or snagged by objects at the side of the road or trail.

- c. Protective eyewear, to protect against airborne dirt, dust and bugs — tinted when the sun is bright, clear under shadow or night conditions.
- f. Your new electric tricycle is not designed for jumping; therefore, do not attempt any kind of jumping with your bike. Jumping a bike, particularly a BMX or mountain bike, can be fun; but it can put huge and unpredictable stress on the tricycle and its components. Riders who insist on jumping their bikes risk serious damage, to their tricycles as well as to themselves.
- g. Your new electric tricycle is sold as a Class II vehicle, meaning it has a maximum assisted speed of 20mph. Please ride at a speed appropriate for the terrain and traffic conditions, higher speed pose higher risks

3.2 Riding Safety

- a. Obey all Rules of the Road and all local traffic laws.
- b. You are sharing the road or the path with others — motorists, pedestrians and other cyclists. Respect their rights.
- c. Ride defensively. Always assume that others do not see you.
- d. Look ahead, and be ready to avoid:
 - a. Vehicles slowing or turning, entering the road or your lane ahead of you, or coming up behind you.
 - b. Parked car doors opening.
 - c. Pedestrians stepping out.
 - d. Children or pets playing near the road.
 - e. Pot holes, sewer grating, railroad tracks, expansion joints, road or sidewalk construction, debris and other obstructions that could cause you to swerve into traffic, catch your wheel or cause you to have an accident.
 - f. The many other hazards and distractions which can occur on a tricycle ride.
- e. Ride in designated bike lanes, on designated bike paths or as close to the edge of the road as practicable, in the direction of traffic flow or as directed by local governing laws.
- f. Stop at stop signs and traffic lights; slow down and look both ways at street intersections. Remember that a bike always loses in a collision with a motor vehicle, so be prepared to yield even if you have the right of way.
- g. Use approved hand signals for turning and stopping.
- h. Never ride with headphones. They mask traffic sounds and emergency vehicle sirens, distract you from concentrating on what's going on around you, and their wires can tangle in the moving parts of the tricycle, causing you to lose control.
- i. Your new electric tricycle has been designed to carry cargo and passengers in a safe way, please make sure to read Section "Cargo" to learn all safety items related to your new cargo tricycle. Your tricycle is not designed for a rear trailer; therefore do not attempt to install this type of accessory. A rear child seat over the rear rack may be possible depending on brand. Check that the seat installation points do not make contact with the battery beneath the rear rack before installing. Do not use a rear child seat with children over 40 lbs. (18 kgs.)

- j. Never carry anything which obstructs your vision, limits the complete control of the tricycle, or which could become entangled in the moving parts of the bike. Your tricycle has a front cargo area; therefore, make sure that sitting passengers or cargo do not obstruct your vision, that you have an adequate road visibility in a normal riding position and that you have full control of the bike.
- k. Never hitch a ride by holding on to another vehicle.
- l. Don't do stunts, wheelies or jumps
- m. Don't weave through traffic or make any moves that may surprise people with whom you are sharing the road.
- n. Observe and yield the right of way.
- o. Never ride your tricycle while under the influence of alcohol or drugs.
- p. If possible, avoid riding in bad weather, when visibility is obscured, at dawn, dusk or in the dark, or when extremely tired. Each of these conditions increases the risk of accident.

3.3 Off Road Safety

Your new electric tricycle is designed to be driven exclusively by licensed drivers aged 16 or older. Younger people or children should not be allowed to ride this tricycle even in off road and/or private land.

When riding off road please take special note of the following information.

- a. The variable conditions and hazards of off-road riding require close attention and specific skills. Start slowly on easier terrain and build up your skills. Get to know how to handle your bike safely before trying increased speed or more difficult terrain.
- b. Wear safety gear appropriate to the kind of riding you plan to do.
- c. Don't ride alone in remote areas. Even when riding with others, make sure that someone knows where you're going and when you expect to be back.
- d. Always take along some kind of identification, so that people know who you are in case of an accident; and take along some cash for food, a cool drink and a phone for emergency phone calls.
- e. Yield right of way to pedestrians and animals. Ride in a way that does not frighten or endanger them and give them enough room so that their unexpected moves don't endanger you.
- f. Be prepared. If something goes wrong while you're riding off-road, help may not be close.
- g. Your tricycle is not designed for jumping, please do not attempt to jump, do stunt riding or race with your bike even in private terrain.
- h. Since electric tricycles are heavier, have an electric motor and the ability to develop higher speeds, maintain a minimum of 15 feet behind the bike in front of you.
- i. Do not use electric assist on level and downhill grades; under these conditions, the maneuverability of the tricycle is greatly reduced and poses a big risk of accident.

3.4 Off Road Respect

Obey the local laws regulating where and how you can ride off-road, and respect private property. You may be sharing the trail with others — hikers, trail runners, equestrians, and other cyclists. Respect their rights. Stay on the designated trail. Don't contribute to erosion by riding in mud or with unnecessary sliding. Don't disturb the ecosystem by cutting your own trail or shortcut through vegetation or streams. It is your responsibility to minimize your impact on the environment. Leave things as you found them; and always take out everything you brought in.

3.5 Wet Weather Riding

 **WARNING: Wet weather impairs traction, braking and visibility, both for the bicyclist and for other vehicles sharing the road. The risk of an accident is dramatically increased in wet conditions.**

Under wet conditions, the stopping power of your brakes (as well as the brakes of other vehicles sharing the road) is dramatically reduced and your tires don't grip nearly as well. This makes it harder to control speed and easier to lose control. To make sure that you can slow down and stop safely in wet conditions, ride more slowly and apply your brakes earlier and more gradually than you would under normal, dry conditions. See also Section 5.3.

Your electric tricycle has several electrical components: motor, battery, controller, display, sensor and lights; these components are waterproof; however, in case of excessive water presence such as in a heavy storm or flooding, water may ingress and cause damage to the electrical components. Therefore, be conscious and avoid riding your bike in case of storm or presence of lightning.

 **CAUTION: Do not remove the battery under the presence of rain. The battery and its receptacle in the bike are waterproof as long as the battery is plugged. Water may ingress to the electrical components of the bike if the battery is not plugged.**

 **CAUTION: Do not expose the battery to heavy rain. Water may ingress inside the battery compartment leading to an extremely unsafe situation.**

 **CAUTION: Do not attempt to ride your tricycle or charge your battery if you have any suspicion that water may have ingress inside the battery.**

If you detect any water ingress to any of the above mentioned components proceed as follows:

a. Stop using the electrical system of your tricycle. Water may cause corrosion which could lead to a bike malfunctioning resulting in serious injury or death.

b. If you detect moisture inside your display, let it dry under direct sunlight (do not expose your display to direct sun light longer than necessary). If moisture is still present after you have let it dry, contact your dealer for a display replacement.

 **WARNING: If you have any suspicion that water may have ingress inside the battery, stop using your bike and do not attempt to charge the battery. Have it checked by your local dealer or contact us for guidance. At the very least, the inner elements of the battery might corrode in the presence of water or moisture, leading to an unsafe situation which can cause a serious injury, death and considerable property damage.**

Your electric tricycle is accompanied by a rain cover accessory to protect the front cargo area from the weather. When using the accessory, please make sure that the accessory does not obstruct your vision and that you have good road visibility. In case your vision is obstructed, avoid using the rain cover accessory as it could create dangerous situations for yourself and others leading to an accident which can cause serious injury or death.

3.6 Night Riding

Riding a tricycle at night is much more dangerous than riding during the day. A bicyclist is very difficult for motorists and pedestrians to see. Therefore, children should never ride at dawn, at dusk or at night. Adults who chose to accept the greatly increased risk of riding at dawn, at dusk or at night need to take extra care both riding and choosing specialized equipment that helps reduce that risk. Consult your dealer about night riding safety equipment. Your electric tricycle is equipped with front, rear, pedal and wheel reflectors as well as front and rear lights. Bicycle reflectors are designed to pick up and reflect car lights and street lights in a way that may help you to be seen and recognized as a moving bicyclist. Additionally, make sure to turn the lights on when riding at night and make sure that they work properly at all times. If you consider that the front light intensity is not enough for you to ride safely, please do equip your tricycle with an additional light.

 **CAUTION: Check reflectors and their mounting brackets regularly to make sure that they are clean, straight, unbroken, and securely mounted. Have your dealer replace damaged reflectors and tighten or tighten any that are bent or loose.**

 **WARNING: Reflectors are not a substitute for required lights. Riding at dawn, dusk, night or at other times of poor visibility without an adequate bicycle lighting system and without reflectors is dangerous and may result in serious injury or death.**

 **WARNING: Do not remove the front or rear reflectors or reflector brackets from your tricycle. They are an integral part of the tricycle's safety system. Removing the reflectors reduces your visibility**

to others using the roadway. Being struck by other vehicles may result in serious injury or death.

If you choose to ride under conditions of poor visibility, check and be sure you comply with all local laws about night riding, and take the following strongly recommended additional precautions:

- In case your local legislation has a specific light requirement, purchase and install battery or generator powered head and tail lights which meet all regulatory requirements for where you live and provide adequate visibility.
- Wear light colored, reflective clothing and accessories, such as a reflective vest, reflective arm and leg bands, reflective stripes on your helmet, flashing lights attached to your body and/or your tricycle; any reflective device or light source that moves will help you get the attention of approaching motorists, pedestrians and other traffic.
- Make sure that your clothing or anything you may be carrying on the tricycle does not obstruct a reflector or light.
- Make sure that your tricycle reflectors are always correctly positioned and securely mounted.
- Ride slowly and avoid dark areas and areas of heavy or fast-moving traffic. If possible, ride on familiar routes to avoid road hazards.

If riding in traffic:

- Be predictable. Ride so that drivers can see you and predict your movements.
- Be alert. Ride defensively and expect the unexpected.
- If you plan to ride in traffic often, ask your dealer about traffic safety classes or a good book on bicycle traffic safety.

3.7 Extreme, Stunt Or Competition Riding

Whether you call it Aggro, Hucking, Freeride, North Shore, Downhill, Jumping, Stunt Riding, Racing, Enduro or something else; your electric tricycle is not designed to perform any of these activities. If you engage in this sort of extreme, aggressive riding, please consider that you voluntarily assume a greatly increased risk of injury or death.

WARNING: Although many catalogs, advertisements and articles about bicycling depict riders engaged in extreme riding, this activity is extremely dangerous, increases your risk of injury or death, and increases the severity of any injury. Remember that the action depicted is being performed by professionals with many years of training and experience. Know your limits and always wear a helmet and other appropriate safety gear. Even with state-of-the-art protective safety gear, you could be seriously injured or killed when jumping, stunt riding, riding downhill at speed or in competition.

WARNING: Tricycles and tricycle parts have limitations with regard to strength and integrity, and they are not designed nor tested for any type of extreme riding. A component malfunction may lead to serious injury or death.

3.8 Changing Components Or Adding Accessories

There are many components and accessories available to enhance the comfort, performance, and appearance of your tricycle. However, if you change components or add accessories, you do so at your own risk. Unless purchased directly from Integral Electrics, it must be assumed that components or accessories have not been tested for compatibility, reliability, or safety on your tricycle. Before installing any component or accessory, including but not limited to a different size tire, a lighting system, a luggage rack, a child seat, a trailer, etc., make sure that it is compatible with your tricycle by checking with your dealer. Be sure to read, understand and follow the instructions that accompany the products you purchase for your tricycle. See also Appendix A, and C.

WARNING: Failure to confirm compatibility, properly install, operate and maintain any component or accessory can result in serious injury or death.

WARNING: Exposed springs on the saddle of any tricycle fitted with a child seat can cause serious injury to the child.

WARNING: Changing the components on your bike with other than genuine replacement parts may compromise the safety of your tricycle and may void the warranty. Check with your dealer before changing the components on your bike.

WARNING: Any accessory or component attached to, on or near a rotating wheel poses a risk of contacting or stopping the wheel, leading to a crash resulting in serious injury or death. Before every ride check to ensure that all such accessories and components, and the fasteners used to attach them, are securely mounted to your tricycle.

WARNING: Any object that unexpectedly and abruptly stops the rotation of the front wheels can cause the bike and rider to pitch forward (fig. 4), which can result in serious injury or death. fig. 4

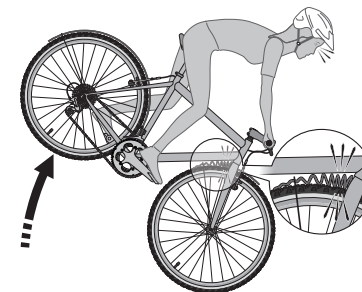

fig. 4

4. FIT

NOTE: Correct fit is an essential element of bicycling safety, performance and comfort. Making the adjustments to your tricycle that result in correct fit for your body and riding conditions requires experience, skill and special tools. Always have your dealer make the adjustments on your tricycle; or, if you have the experience, skill and tools, have your dealer check your work before riding.

⚠ WARNING: If your tricycle does not fit properly, you may lose control and fall. If your new bike doesn't fit, ask your dealer to exchange it before you ride it.

4.1 Stand Over Height

Your tricycle integrates a step-through frame; therefore, stand over height is not applicable to it. Instead, the limiting dimension is determined by saddle height range. You must be able to adjust your saddle position as described in Section 4.2 without exceeding the limits set by the height of the top of the seat tube and the "Minimum Insertion" or "Maximum Extension" mark on the seat post.

4.2 Saddle Position

Correct saddle adjustment is an important factor in getting the most performance and comfort from your tricycle. If the saddle position is not comfortable for you, see your dealer. The saddle can be adjusted in three directions:

4.2.1 Up and Down Adjustment

To check for correct saddle height (fig. 5):

- Sit on the saddle;
- Place one heel on a pedal;
- Rotate the crank until the pedal with your heel on it is in the down position and the crank arm is parallel to the seat tube.

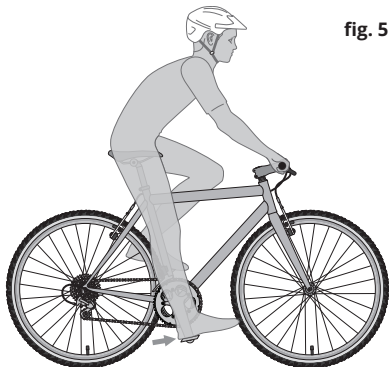

If your leg is not completely straight, your saddle height needs to be adjusted. If your hips must rock for the heel to reach the pedal, the saddle is too high. If your leg is bent at the knee with your heel on the pedal, the saddle is too low. Ask your dealer to set the saddle for your optimal riding position and to show you how to make this adjustment. If you choose to make your own saddle height adjustment:

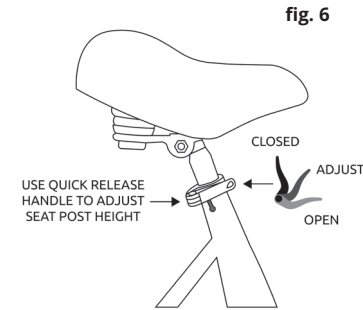

- Loosen the seat post clamp;
- Raise or lower the seat post in the seat tube;
- Make sure the saddle is straight fore and aft;
- Re-tighten the seat post clamp to the recommended torque (Appendix D or the manufacturer's instructions).

Once the saddle is at the correct height, make sure that the seat post does not project from the frame beyond its "Minimum Insertion" or "Maximum Extension" mark (fig. 6).

⚠ WARNING: If your seat post is not inserted in the seat tube as described in above, the seat post, binder or even frame may break, which could cause you to lose control and fall.

4.2.2 Front and Back Adjustment

The saddle can be adjusted forward or back to help you get the optimal position on the bike. Ask your dealer to set the saddle for your optimal riding position and to show you how to make this adjustment. If you choose to make your own front and back adjustment, make sure that the clamp mechanism is clamping on the straight part of the saddle rails and is not touching the curved part of the rails, and that you are using the recommended torque on the clamping fastener(s) (Appendix D or the manufacturer's instructions).

⚠ WARNING: The saddle rails have marks indicating the clamping limits, never clamp beyond these marks as it could lead to saddle failure which could cause you to lose control and fall.

4.2.3 Saddle Angle Adjustment

Most people prefer a horizontal saddle; but some riders like the saddle nose angled up or down just a little. Your dealer can adjust saddle angle or teach you how to do it. If you choose to make your own saddle angle adjustment and you have a single bolt saddle clamp on your seat post, it is critical that you loosen the clamp bolt sufficiently to allow any serrations on the mechanism to disengage before changing the saddle's angle, and then that the serrations fully re-engage before you tighten the clamp bolt to the recommended torque (Appendix D or the manufacturer's instructions).

 **WARNING:** When making saddle angle adjustments with a single bolt saddle clamp, always check to make sure that the serrations on the mating surfaces of the clamp are not worn. Worn serrations on the clamp can allow the saddle to move, causing you to lose control and fall.

 **CAUTION:** Always tighten fasteners to the correct torque. Bolts that are too tight can stretch and deform. Bolts that are too loose can move and fatigue. Either mistake can lead to a sudden failure of the bolt, causing you to lose control and fall.

NOTE: Small changes in saddle position can have a substantial effect on performance and comfort. To find your best saddle position, make only one adjustment at a time.

 **WARNING:** After any saddle adjustment, be sure that the saddle adjusting mechanism is properly seated and tightened before riding. A loose saddle clamp or seat post clamp can cause damage to the seat post, or can cause you to lose control and fall. A correctly tightened saddle adjusting mechanism will allow no saddle movement in any direction. Periodically check to make sure that the saddle adjusting mechanism is properly tightened.

If, in spite of carefully adjusting the saddle height, tilt and fore-and-aft position, your saddle is still uncomfortable, you may need a different saddle design. Saddles, like people, come in many different shapes, sizes and resilience. Your dealer can help you select a saddle which, when correctly adjusted for your body and riding style, will be comfortable.

 **WARNING:** Some people have claimed that extended riding with a saddle which is incorrectly adjusted or which does not support your pelvic area correctly can cause short-term or long-term injury to nerves and blood vessels, or even impotence. If your saddle causes you pain, numbness or other discomfort, listen to your body and stop riding until you see your dealer about saddle adjustment or a different saddle.

4.3 Handlebar Height And Angle

The handlebar construction of your new tricycle differs from that of a traditional bicycle due to the nature of your new vehicle. Therefore, some adjustments available in traditional stem-handlebar constructions are not available, for instance the angle.

To assemble the handlebar, please follow the next steps:

- a. Align and insert the handlebar in the 2 holes at the back of the cargo box.
- b. Set the position most convenient according to your height.
- c. Tighten the screws to secure the handlebar.

 **WARNING:** Changing the handlebar height can affect the tension of the brake cables, locking the brakes or creating excess slack which can make the brake inoperable. Always check that the brakes are correctly adjusted after performing any change in your handlebar height and angle.

 **WARNING:** Always tighten fasteners to the correct torque. Bolts that are too tight can stretch and deform. Bolts that are too loose can move and fatigue. Either mistake can lead to a sudden failure of the bolt, causing you to lose control and fall.

 **WARNING:** Your electric tricycle is not designed to install aerodynamic extensions to handlebars, do not attempt to do it as this could lead to lose control and fall.

4.4 Control Position Adjustments

The angle of the brake and shift control levers and their position on the handlebars can be changed. Ask your dealer to make the adjustments for you. If you choose to make your own control lever angle adjustment, be sure to re-tighten the clamp fasteners to the recommended torque (Appendix D or the manufacturer's instructions).

4.5 Brake Reach

Many bikes have brake levers that can be adjusted for reach. If you have small hands or find it difficult to squeeze the brake levers, your dealer can either adjust the reach or fit shorter reach brake levers.

 **WARNING:** The shorter the brake lever reach, the more critical it is to have correctly adjusted brakes, so that full braking power can be applied within available brake lever travel. Brake lever travel insufficient to apply full braking power can result in loss of control, which may result in serious injury or death.

5. TECH

It's important to your safety, performance and enjoyment to understand how things work on your tricycle. We urge you to ask your dealer how to do the things described in this section before you attempt them yourself, and that you have your dealer check your work before you ride the bike. If you have even the slightest doubt as to whether you understand something in this section of the Manual, talk to your dealer or contact Integral Electrics directly.. See also Appendix B, C and D. To see the exact specification of the components available in your tricycle, refer to Appendix E.

5.1 Wheels

Tricycle wheels are designed to be removable for easier transportation and for repair of a tire puncture. The wheel axles are inserted into slots, called "dropouts" in the fork and frame.

It is very important that you understand the type of wheel securing method on your tricycle, that you know how to secure the wheels correctly, and that you know how to apply the correct clamping force that safely secures the wheel. Ask your dealer to instruct you in correct wheel removal and installation and ask him to give you any available manufacturer's instructions.

- ! WARNING: Riding with an improperly secured wheel can allow the wheel to wobble or fall off the tricycle, which can cause serious injury or death. Therefore, it is essential that you:**
- Ask your dealer to help you make sure you know how to install and remove your wheels safely.**
 - Understand and apply the correct technique for clamping your wheel in place.**
 - Each time, before you ride the bike, check that the wheel is securely clamped. The clamping action of a correctly secured wheel must emboss the surfaces of the dropouts.**

5.1.1 Front Wheels

The front wheels are fitted with a hollow axle with a shaft ("skewer") running through it which has a nut on one end and a fitting for a hex key (through-bolt, fig. 7). Make sure to completely read the instructions in this chapter, and follow them when installing or removing the front wheels. If you don't know what a thru axle is, ask your dealer.

If you intend to replace the skewer or any of its parts, make sure that the new skewer is compatible with your tricycle. Do not remove the skewer from your tricycle and use it on a different tricycle, as it may not be compatible and will not properly secure your wheels. If you have any questions, please reach out to your dealer, or contact us.

A secondary wheel retention mechanism is considered to reduce the risk of the wheels disengaging from the fork if the wheels are incorrectly secured.

In case the nut or the through-bolt are not completely secured, the skewer will keep the wheels in place; however please note that secondary retention devices are not a substitute for correctly securing your front wheels.

! WARNING: A wheel attachment device that is not properly secured can allow the wheels to loosen or come off, suddenly stop the wheels, decrease your control, and cause you to fall, resulting in serious injury or death. Ensure the skewer or any of its parts is not interfering with any part of the tricycle and is fully secured.

WARNING: Do not remove or disable the secondary retention device. As its name implies, it serves as a back-up for a critical adjustment. If the wheels are not secured correctly, the secondary retention device can reduce the risk of the wheels disengaging from the fork. Removing or disabling the secondary retention device may also void the warranty.

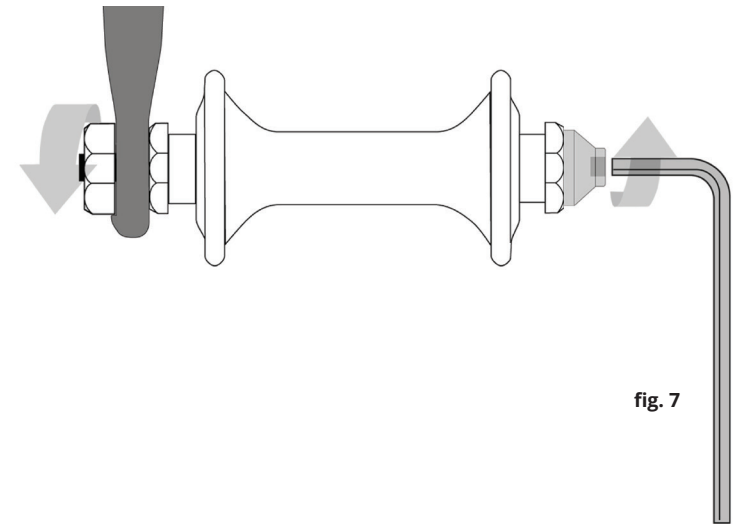

Secondary retention devices are not a substitute for correctly securing your wheels. Failure to properly secure the wheels can cause the wheels to wobble or disengage, which could cause you to lose control and fall, resulting in serious injury or death.

5.1.2 Rear Wheel

The rear wheel is fitted with a hub motor and uses hex nuts to secure the hub axle to the dropouts, this is called a bolt-on wheel (bolt-on wheel, fig. 10). Make sure to completely read the instructions in this chapter and follow them when installing or removing the rear wheel. If you don't know what a thru axle is, ask your dealer.

A secondary wheel retention mechanism is considered to reduce the risk of

the wheel disengaging from the fork if the wheel is incorrectly secured. In case the hex nuts are not completely secured, the safety washer will keep the wheel in place; however please note that secondary retention devices are not a substitute for correctly securing your front wheel.

WARNING: A wheel attachment device that is not properly secured can allow the wheel to loosen or come off, suddenly stop the wheel, decrease your control, and cause you to fall, resulting in serious injury or death. Ensure the skewer or any of its parts is not interfering with any part of the tricycle and is fully secured.

WARNING: Do not remove or disable the secondary retention device. As its name implies, it serves as a back-up for a critical adjustment. If the wheel is not secured correctly, the secondary retention device can reduce the risk of the wheel disengaging from the fork. Removing or disabling the secondary retention device may also void the warranty.

Secondary retention devices are not a substitute for correctly securing your wheel. Failure to properly secure the wheel can cause the wheel to wobble or disengage, which could cause you to lose control and fall, resulting in serious injury or death.

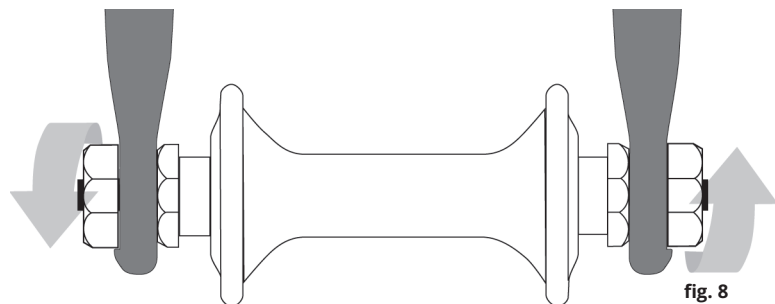

5.1.3 Removing & Installing The Front Wheels

CAUTION: Your tricycle is equipped with a disc brake; exercise care in touching the rotor or caliper. Disc rotors have sharp edges, and both rotor and caliper can get very hot during use.

To remove the front wheel, follow the next steps.

- Put the tricycle in a way that is safe for you and the people around.
- Secure the rear wheel using the feature available in the hand brake.
- Loosen the hex fasteners holding the disk brake caliper.
- Remove the brake caliper.
- Loosen the wheel hex fastener until it is completely loose.
- Slide the wheel towards the outside.

When removing any of the front wheels, make sure that you provide adequate support for the tricycle so it does not fall.

To install the front wheels, follow the next steps.

CAUTION: Your bike is equipped with a front disk brake, be careful not to damage the disk, caliper or brake pads when re-inserting the disk into the caliper. Never activate a disk brake's control lever unless the disk is correctly inserted in the caliper.

- Put the tricycle in a way that is safe for you and the people around.
- Secure the rear wheel using the feature available in the hand brake.
- Slide the wheel hub through the axle.
- Fasten the hex fastener to the torque specifications in Appendix D or the hub manufacturer's instructions to secure the wheel.
- Fasten the brake caliper to the torque specifications in Appendix D.
- Spin the wheel to make sure that it is centered in the frame and clears the brake pads; then squeeze the brake lever and make sure that the brakes are operating correctly.

5.1.4 Removing And Installing The Rear Wheel

CAUTION: Your tricycle is equipped with a disc brake; exercise care in touching the rotor or caliper. Disc rotors have sharp edges, and both rotor and caliper can get very hot during use.

To remove the rear wheel follow the next steps.

- Put the tricycle in a way that is safe for you and the people around.
- Secure the front wheels using the feature available in the hand brake.
- Your bike has a derailleur gear system; shift the rear derailleur to high gear (the smallest, outermost rear sprocket).
- Disconnect the motor wire and make sure the cable coming out of the motor is loose and is not fixed to the bike frame.
- Loosen the hex nuts using the wrench to loosen the hub axle.
- Pull the derailleur body back with your right hand.
- While raising the tricycle, push the rear wheel forward far enough to be able to remove the chain from the rear sprocket, then lift the rear wheel off the ground a few inches and remove it from the rear dropouts.

To install the rear wheel, at least 2 people are required, follow the next steps.

CAUTION: Your bike is equipped with a rear disk brake, be careful not to damage the disk, caliper or brake pads when re-inserting the disk into the caliper. Never activate a disk brake's control lever unless the disk is correctly inserted in the caliper.

- Put the tricycle in a way that is safe for you and the people around.
- Secure the front wheels using the feature available in the hand brake.
- Make sure that the rear derailleur is still in its outermost, high gear, position; then pull the derailleur body back with your right hand. Put the chain on top of the smallest freewheel sprocket.
- Insert the wheel into the frame dropouts and pull it all the way in to the

- dropouts.
- e. Tighten the fasteners to the torque specifications in Appendix D or the hub manufacturer's instructions.
- f. Spin the wheel to make sure that it is centered in the frame and clears the brake pads; then squeeze the brake lever and make sure that the brakes are operating correctly.

5.2 Seat Post Cam Action Clamp

Your bike is equipped with a cam action seat post binder. The seat post cam action binder works exactly like the traditional wheel cam action fastener (Section 4.A.2). While a cam action binder looks like a long bolt with a lever on one end and a nut on the other, the binder uses an over-center cam action to firmly clamp the seat post (see fig. 9)

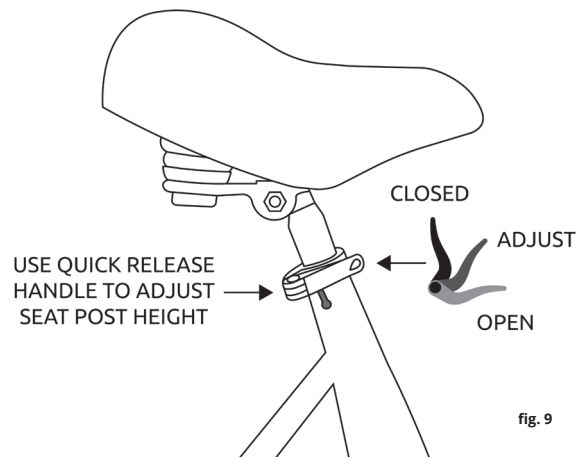

WARNING: Riding with an improperly tightened seat post can allow the saddle to turn or move and cause you to lose control and fall. Therefore:

- a. Ask your dealer to help you make sure you know how to correctly clamp your seat post.
- b. Understand and apply the correct technique for clamping your seat post.
- c. Before you ride the bike, first check that the seat post is securely clamped.

5.2.1 Adjusting The Seat Post Cam Action Mechanism

The action of the cam squeezes the seat collar around the seat post to hold the seat post securely in place. The amount of clamping force is controlled by the tension adjusting nut. Turning the tension adjusting nut clockwise while keeping the cam lever from rotating increases clamping force; turning it counterclockwise while keeping the cam lever from rotating reduces clamping force. Less than half a turn of the tension adjusting nut can make the difference between safe and unsafe clamping force.

WARNING: The full force of the cam action is needed to clamp the seat post securely. Holding the nut with one hand and turning the lever like a wing nut with the other hand until everything is as tight as you can get it will not clamp the seat post safely.

WARNING: If you can fully close the cam lever without wrapping your fingers around the seat post or a frame tube for leverage, and the lever does not leave a clear imprint in the palm of your hand, the tension is insufficient. Open the lever; turn the tension adjusting nut clockwise a quarter turn; then try again.

5.3 Brakes

Your tricycle is equipped with hydraulic disc brakes; these brakes operate by squeezing a hub-mounted disc between two brake pads. The brakes are actuated by way of a handlebar mounted lever.

WARNING: Riding with improperly adjusted brakes, worn brake pads, or wheels on which the rim wear mark is visible is dangerous and can result in serious injury or death. fig. 1

WARNING: Applying brakes too hard or too suddenly can lock up a wheel, which could cause you to lose control and fall (see fig. 1). Sudden or excessive application of the front brake may cause you to lose control, which may result in serious injury or death.

WARNING: Trikes can tip if the driver takes turns too fast or too sharp. Be sure the slow down appropriately for turns to maintain stability (see fig. 1)

WARNING: Some tricycle brakes, such as disc brakes (fig. 10) and linear-pull brakes (fig. 11) are extremely powerful. Take extra care in becoming familiar with these brakes and exercise particular care when using them.

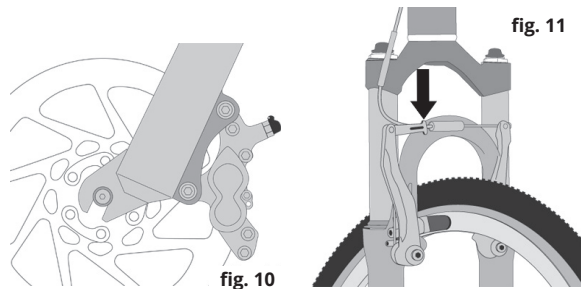

WARNING: Some tricycle brakes are equipped with a brake force modulator, a small, cylindrical device through which the brake control cable runs and which is designed to provide a more progressive application of braking force. A modulator makes the initial brake lever force more gentle, progressively increasing force until full force is achieved. If your bike is equipped with a brake force modulator, take extra care in becoming familiar with its performance characteristics. Some brake force modulators are adjustable. If you don't like the feel of your brakes, ask your dealer about adjusting the brake force modulation.

WARNING: Disc brakes can get extremely hot with extended use. Be careful not to touch a disc brake until it has had plenty of time to cool.

WARNING: See the brake manufacturer's instructions for operation and care of your brakes, and for when brake pads must be replaced. If you do not have the manufacturer's instructions, see your dealer or contact the brake manufacturer.

WARNING: If replacing worn or damaged parts, use only manufacturer-approved genuine replacement parts.

5.3.1 Brake Controls And Features

It's very important to your safety that you learn and remember which brake lever controls which brake on your bike. Traditionally, in the U.S. the right brake lever controls the rear brake and the left brake lever controls the front brake; this is the way your new bike is configured. To check how your bike's brakes are set up, squeeze one brake lever and look to see which brake, front or rear, engages. Now do the same with the other brake lever.

Make sure that your hands can reach and squeeze the brake levers comfortably. If your hands are too small to operate the levers comfortably, consult your dealer before riding the bike. The lever reach may be adjustable; or you may need a different brake lever design.

5.3.2 How Brakes Work

The braking action of a tricycle is a function of the friction between the

braking surfaces. To make sure that you have maximum friction available, keep your disk rotor and caliper clean and free of dirt, lubricants, waxes or polishes.

Brakes are designed to control your speed, not just to stop the bike. Maximum braking force for each wheel occurs at the point just before the wheel "locks up" (stops rotating) and starts to skid. Once the tire skids, you actually lose most of your stopping force and all directional control. You need to practice slowing and stopping smoothly without locking up a wheel. The technique is called progressive brake modulation. Instead of jerking the brake lever to the position where you think you'll generate appropriate braking force, squeeze the lever, progressively increasing the braking force. If you feel the wheel begin to lock up, release pressure just a little to keep the wheel rotating just short of lockup. It's important to develop a feel for the amount of brake lever pressure required for each wheel at different speeds and on different surfaces. To better understand this, experiment a little by walking your bike and applying different amounts of pressure to each brake lever, until the wheel locks.

When you apply one or both brakes, the bike begins to slow, but your body wants to continue at the speed at which it was going. This causes a transfer of weight to the front wheel (or, under heavy braking, around the front wheel hub, which could cause you to lose control and fall).

A wheel with more weight on it will accept greater brake pressure before lockup; a wheel with less weight will lock up with less brake pressure.

So, as you apply brakes and your weight is transferred forward, you need to shift your body toward the rear of the bike, to transfer weight back on to the rear wheel; and at the same time, you need to both decrease rear braking and increase front braking force. This is even more important on descents, because descents shift weight forward.

Two keys to effective speed control and safe stopping are controlling wheel lockup and weight transfer. This weight transfer is even more pronounced if your bike has a front suspension fork. Front suspension "dips/compresses/dives" under braking, increasing the weight transfer. Practice braking and weight transfer techniques where there is no traffic or other hazards and distractions.

Everything changes when you ride on loose surfaces or in wet weather. It will take longer to stop on loose surfaces or in wet weather. Tire adhesion is reduced, so the wheels have less cornering and braking traction and can lock up with less brake force. Moisture or dirt on the brake pads reduces their ability to grip. The way to maintain control on loose or wet surfaces is to go more slowly.

5.4 Shifting Gears

Your multi-speed tricycle has a derailleur drivetrain and a single front gear. The gear-changing mechanism will have:

- Rear cassette or freewheel sprocket cluster
- Rear derailleur
- Gear shifter
- Front gear
- One, two or three front sprockets called chainrings
- Drive chain

There are several different types and styles of shifting controls: levers, twist grips, triggers, combination shift/brake controls and push-buttons. Your bike is equipped with a combination of trigger and push-button. Ask your dealer to explain the type of shifting controls that are on your bike, and to show you how they work.

The vocabulary of shifting can be pretty confusing. A downshift is a shift to a “lower” or “slower” gear, one that is easier to pedal. An upshift is a shift to a “higher” or “faster”, harder to pedal gear. What’s confusing is that what’s happening at the front derailleur is the opposite of what’s happening at the rear derailleur (for details, read the instructions on Shifting the Rear Derailleur and Shifting the Front Derailleur below). For example, you can select a gear which will make pedaling easier on a hill (make a downshift) in one of two ways: shift the chain down the gear “steps” to a smaller gear at the front, or up the gear “steps” to a larger gear at the rear. So, at the rear gear cluster, what is called a downshift looks like an upshift. The way to keep things straight is to remember that shifting the chain in towards the centerline of the bike is for accelerating and climbing and is called a downshift. Moving the chain out or away from the centerline of the bike is for speed and is called an upshift.

Whether upshifting or downshifting, the tricycle derailleur system design requires that the drive chain be moving forward and be under at least some tension. A derailleur will shift only if you are pedaling forward.

CAUTION: Never move the shifter while pedaling backward, nor pedal backward immediately after having moved the shifter. This could jam the chain and cause serious damage to the tricycle.

5.4.1 Shifting The Rear Derailleur

The rear derailleur is controlled by the right shifter. The function of the rear derailleur is to move the drive chain from one gear sprocket to another. The smaller sprockets on the gear cluster produce higher gear ratios. Pedaling in the higher gears requires greater pedaling effort, but takes you a greater distance with each revolution of the pedal cranks. The larger sprockets produce lower gear ratios. Using them requires less pedaling effort, but takes you a shorter distance with each pedal crank revolution. Moving the chain

from a smaller sprocket of the gear cluster to a larger sprocket results in a downshift. Moving the chain from a larger sprocket to a smaller sprocket results in an upshift. In order for the derailleur to move the chain from one sprocket to another, the rider must be pedaling forward.

Your bike has a gear shifter as the one shown in the next image; to downshift you need to activate the trigger by pressing it, one click means one gear change. To upshift, you need to activate the button by pressing it, again, one click means one gear change.

Gear change should be performed while the bike is in movement and preferably, without applying torque to the pedals. Always perform one gear change at a time.

fig. 12

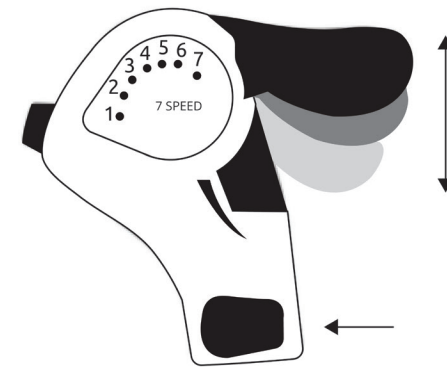

5.4.2 Which Gear Should I Be In?

The largest rear gear gives you the most torque per pedal stroke meaning that it will make easier to pedal through the steepest hills; on the other hand, you will not be able to develop higher speeds. The smallest rear gear is meant for the greatest speed. It is not necessary to shift gears in sequence. Instead, find the “starting gear” which is right for your level of ability — a gear which is hard enough for quick acceleration but easy enough to let you start from a stop without wobbling — and experiment with upshifting and downshifting to get a feel for the different gear combinations.

At first, practice shifting where there are no obstacles, hazards or other traffic, until you’ve built up your confidence. Learn to anticipate the need to shift, and shift to a lower gear before the hill gets too steep. If you have difficulties with shifting, the problem could be mechanical adjustment. See your dealer for help.



WARNING: Never shift a derailleur onto the largest or the smallest sprocket if the derailleur is not shifting smoothly. The derailleur

may be out of adjustment and the chain could jam, causing you to lose control and fall.

 **CAUTION: If moving the shift control, one click repeatedly fails to result in a smooth shift to the next gear chances are that the mechanism is out of adjustment. Take the bike to your dealer to have it adjusted.**

5.5 Pedals

Your bike comes equipped with a pair of pedals; they are not identical and each of them is identified either as “LEFT” or “RIGHT”. Depending on your bike model and version different type of pedals might have been included, refer to the specification sheet in Appendix E to know the exact type included with your bike.

CAUTION: If you received two LEFT or RIGHT pedals, do not attempt to install them and contact your dealer immediately. You may cause irreversible damage to the crank arms if you attempt to install a wrong pedal.

5.5.1 Removing And Installing The Pedals

To install the pedals follow the next steps.

- a. Grease threads of both pedals. (New pedals come with lubricant pre-applied).
- b. Using fingers on wrench flats, thread right side pedal into right crank in clockwise direction. Use wrench to snug pedal.
- c. Position wrench on flats for good mechanical advantage. Hold wrench with one hand while holding opposite crank with other. (Pedal the bike backward to install both left and right.)
- d. Using opposite arm as second lever, tighten pedal. Repeat process for left pedal, but threading pedal counter-clockwise to install.

To remove the pedals follow the next steps.

- a. Rotate bike until right pedal is easily accessed.
- b. Try different wrench positions until wrench and crank arm form an angle of 90 degrees or less. Correct mechanical advantage is critical on pedals, which are often overly tight.
- c. If possible, grab opposite crank for second lever. Turn pedal wrench counter-clockwise to remove right pedal or turn crank so the pedal is pedaling forward. Use care not to abrade skin. Continue to turn wrench counter-clockwise and remove pedal completely from crank.
- d. Rotate bike as necessary until left pedal is easily accessed.
- e. Position pedal wrench for good mechanical advantage onto left pedal, and grab right crank for second lever.
- f. Turn pedal wrench clock-wise to remove left pedal or turn crank so the pedal is pedaling forward. Remove left pedal completely from crank.

5.5.2 Toe Overlap

Toe Overlap is when your toe can touch the front wheel when you turn the handlebars to steer while a pedal is in the forward-most position. This is common on small-framed tricycles and is avoided by keeping the inside pedal up and the outside pedal down when making sharp turns. On any tricycle, this technique will also prevent the inside pedal from striking the ground in a turn.

NOTE: Changing tire size or pedal crank arm length affects toe overlap.

 **WARNING: Toe Overlap could cause you to lose control and fall. Ask your dealer to help you determine if the combination of frame size, crank arm length, pedal design and shoes you will use results in pedal overlap. Whether you have overlap or not, you must keep the inside pedal up and the outside pedal down when making sharp turns.**

5.6 Tires And Tubes

Depending on your bike model and version, different types of tires and tubes might have been included, refer to the specification sheet in Appendix E to know the exact type included with your bike.

 **WARNING: Some tricycles intended for competition are fitted with tires that are glued on to specially made rims. These are called “sew-up” or “tubular” tires. Properly mounting these tires requires specialized knowledge and skills. Ask your dealer to teach you how to mount tubulars before you attempt it on your own. An incorrectly installed tubular tire can come off the rim, causing you to lose control and fall.**

5.6.1 Tires

Tricycle tires are available in many designs and specifications, ranging from general-purpose designs to tires designed to perform best under very specific weather or terrain conditions. If, once you’ve gained experience with your new bike, you feel that a different tire might better suit your riding needs, your dealer can help you select the most appropriate design.

The size, pressure rating, and on some high-performance tires the specific recommended use, are marked on the sidewall of the tire (fig. 13). Some wheel rim manufacturers also specify maximum tire pressure with a label on the rim.

The best and safest way to inflate a tricycle tire to the correct pressure is with a bicycle pump that has a built-in pressure gauge.

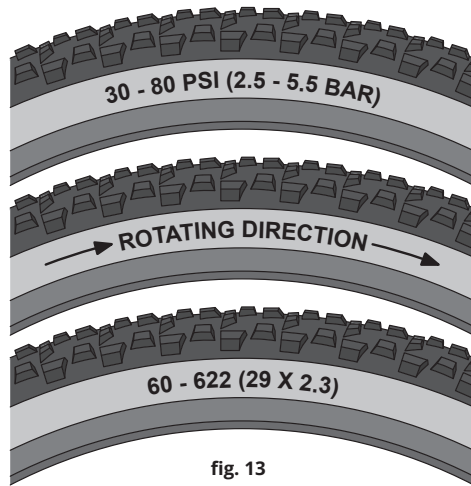

fig. 13

WARNING: There is a safety risk in using gas station air hoses or other air compressors. They are not made for bicycle tires. They move a large volume of air very rapidly, and will raise the pressure in your tire very rapidly, which could cause the tube to explode.

CAUTION: Pencil-type automotive tire gauges can be inaccurate and should not be relied upon for consistent, accurate pressure readings. Instead, use a high-quality dial or digital gauge.

Tire pressure is given either as maximum pressure or as a pressure range. How a tire performs under different terrain or weather conditions depends largely on tire pressure. Inflating the tire to near its maximum recommended pressure gives the lowest rolling resistance, but also produces the harshest ride. High pressures work best on smooth, dry pavement.

Very low pressures, at the bottom of the recommended pressure range, give the best performance on smooth, slick terrain such as hard-packed clay, and on deep, loose surfaces such as deep, dry sand.

Tire pressure that is too low for your weight and the riding conditions can cause a puncture of the tube by allowing the tire to deform sufficiently to pinch the inner tube between the rim and the riding surface. This may also result in rim damage.

WARNING: Never inflate a tire beyond the maximum pressure marked on the tire's sidewall or the wheel rim. If the maximum pressure rating for the wheel rim is different from the maximum pressure shown on the tire, always use the lower rating. Exceeding the recommended maximum pressure may blow the tire off the rim or damage the wheel rim during installation or while riding, resulting in a

loss of control or crash causing serious injury or death, as well as damage to the tire, tube, and/or wheel rim.

WARNING: Never ride a tire inflated below the minimum pressure marked on the tire's sidewall. Tire pressure below the minimum may cause a flat tire and/or the tire to detach from the rim while riding, resulting in a loss of control or crash causing serious injury or death, as well as damage to the tire, tube, and/or wheel rim.

Ask your dealer to recommend the best tire pressure for the kind of riding you will most often do, and have the dealer inflate your tires to that pressure. Then, check inflation as described in Section 2.4.2 so you'll know how correctly inflated tires should look and feel when you don't have access to a gauge. Some tires may need to be brought up to pressure every week or two, so it is important to check your tire pressures before every ride. Some special high-performance tires have unidirectional treads: their tread pattern is designed to work better in one direction than in the other. The sidewall marking of a unidirectional tire will have an arrow showing the correct rotation direction. If your bike has unidirectional tires, be sure that they are mounted to rotate in the correct direction.

5.6.2 Tubeless Rims And Tires

Your tricycle does not come equipped with tubeless rims and tires; should you decide to install this type of rim and tire, make sure to follow the manufacturer's instructions and ask your dealer for compatibility and safety.

WARNING: Riding on an improperly installed, incompatible or damaged tubeless tire and rim combination can cause the tire to unexpectedly lose pressure and detach from the rim, resulting in a crash causing serious injury or death. Ensure the components are compatible according to the component manufacturers before installation.

CAUTION: During installation, an incompatible or damaged tubeless tire and rim combination can cause the tire to unexpectedly lose pressure and tire sealant and detach from the rim, resulting in damage to the wheel or other components, and may injure the installer. Use of eye and ear protection is recommended. Ensure the components are compatible according to the component manufacturers before installation.

5.6.3 Tire And Rim Width/Diameter

Wheel rims and tires come in a wide range of diameters (fig. 14) and widths (fig. 15). The nominal diameter of the rim (A) must match the nominal diameter of the tire (B), and the width of the rim (C) must be compatible with the width of the tire (D).

Always follow the rim and tire manufacturer's recommendations concerning tire models and sizes that are compatible with your specific rims.

WARNING: Failure to use a compatible tire and rim combination can cause the tire to unexpectedly lose pressure and detach from the rim, resulting in a crash causing serious injury or death. Ensure the components are compatible according to the component manufacturers before installation.

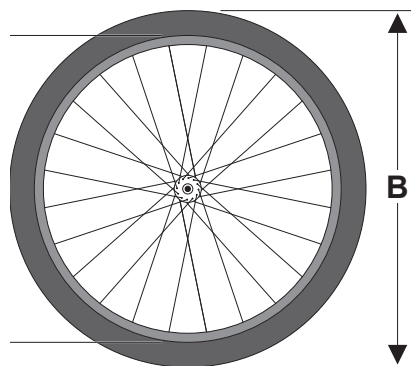

fig. 14

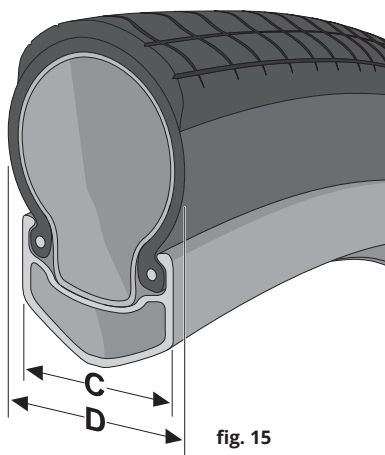

fig. 15

5.6.4 Tire Clearance

The diameter and width of the original equipment wheels and tires on your tricycle have been selected to ensure they provide adequate clearance between the rotating tire and wheel, and the frame, fork, or other components. Any change to your wheels or tires can affect this clearance.

Tires that are marked as being the same size may have different widths when installed, properly inflated and mounted on your bike. Always verify your tire clearance with the tires mounted and fully inflated even if the replacement tires are marked as being the same size as the tires that are being replaced.

Minimum clearance between a properly inflated tire and any part of the bike typically should be at least 6mm (fig. 16 & 17). Some regulations allow for clearance as low as 1.6mm. Please refer to your local dealer or your bike manufacturer for additional information about tire clearance.

Always maintain enough clearance between the rotating tire and rim (fig. 16 & 17), and the frame, fork, or other components. Regularly inspect the frame and fork for damage, as well as the area around the wheel for debris or objects that could become stuck.

When riding your bike, the tires must not be able to contact the fork, frame or any components when a suspension system is fully compressed

or the wheels are subjected to flex from side loads. For example, with a suspension fork, the front tire must clear the fork crown when the fork is fully compressed.

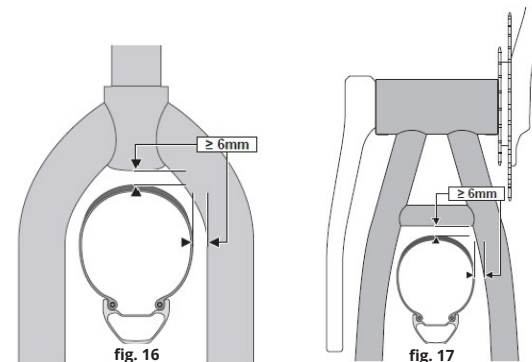

WARNING: Inadequate tire clearance can allow debris or objects to become trapped or cause the wheels to stop unexpectedly, which could cause a crash resulting in serious injury or death.

WARNING: Inadequate tire clearance that results in contact between the tire and any part of the tricycle can result in damage which can lead to failure, which could cause a crash resulting in serious injury or death.

If you have mounted additional accessories or components on your tricycle, particularly fenders, these products may require additional clearance between the tire/wheel and the accessory or component. You should verify the required clearance for any accessory or component mounted on your tricycle with the manufacturer, and do not use the product if the specified clearance cannot be maintained. For additional information on changing components or adding accessories, see section 3.8.

WARNING: Any accessory or component attached to, on or near a rotating wheel poses a risk of contacting or stopping the wheel, leading to a crash resulting in serious injury or death. Before every ride check to ensure that all such accessories and components, and the fasteners used to attach them, are securely mounted to your tricycle.

WARNING: Any object that unexpectedly and abruptly stops the rotation of the front wheels can cause the bike and rider to pitch forward (fig. 4), which can result in serious injury or death.

5.6.5 Tire Valves

There are primarily two kinds of tricycle tire valves: The Schrader Valve and the Presta Valve. The bicycle pump you use must have the fitting appropriate to the valve stems on your tricycle. Please refer to Appendix E to know the

specific valve installed in your tricycle.

The Schrader valve (fig. 18) is like the valve on a car tire. To inflate a Schrader valve tire, remove the valve cap and clamp the pump fitting onto the end of the valve stem. To let air out of a Schrader valve, depress the pin in the end of the valve stem with the end of a key or other appropriate object.

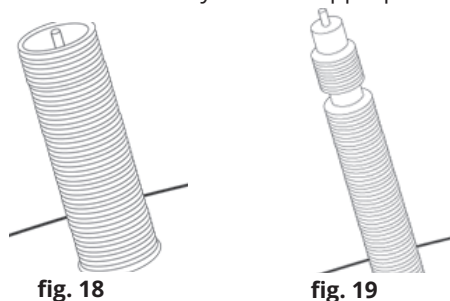

The Presta valve (fig. 19) has a narrower diameter and is only found on bicycle tires. To inflate a Presta valve tire using a Presta headed tricycle pump, remove the valve cap; unscrew (counterclockwise) the valve stem lock nut; and push down on the valve stem to free it up. Then push the pump head on to the valve head, and inflate. To inflate a Presta valve with a Schrader pump fitting, you'll need a Presta adapter (available at your bike shop) which screws on to the valve stem once you've freed up the valve. The adapter fits into the Schrader pump fitting. Close the valve after inflation. To let air out of a Presta valve, open up the valve stem lock nut and depress the valve stem.

⚠ WARNING: We highly recommend that you carry a spare inner tube when you ride your bike. Patching a tube is an emergency repair. If you do not apply the patch correctly or apply several patches, the tube can fail, resulting in possible tube failure, which could cause you to lose control and fall. Replace a patched tube as soon as possible.

6. ELECTRIC BIKES

Your tricycle is equipped with an electric system which provides you with assistance during cycling. In this section the characteristics of the electric system included in your bike are explained.

6.1 Knowing Your Bike

The electric system in your bike is made by the following components:

- Motor
- Li-Ion battery
- Pedal sensor
- Display and throttle
- Charger

6.1.1 Motor

Your electric tricycle is equipped with a hub motor. The motor sits in the center of the rear wheel, and drives that wheel directly. The hub motor's axle is held fixed in either the rear dropouts, and its shell is spun by internal electronics. The rotation of a hub motor is independent of any bicycle drivetrain components, like the cranks, derailleur, or cassette.

The rear hub motor usually gives the best handling characteristics, which means the bike is easier to control. Hub motors are further classified by whether they are gearless (direct drive), or geared. Geared motors are built with internal planetary reduction gearing. They give high torque at low speeds, and freewheel without any drag. Gearless motors generally reach higher speeds than geared motors, are quieter (some are completely silent), can be rated for higher wattage, and are capable of regenerative braking. They also produce less torque, especially at low speed, and have some inherent drag when freewheeling. Your bike is equipped with a geared motor.

Electric bike motors are generally classified by wattage and torque. Watts are a measurement of the capacity of the motor to do work. A motor that is consuming more watts feels more powerful and usually reaches higher speeds, but drains the battery faster. Torque is measured in Newton- meters and is a measurement of the rotating force produced by the motor. This is most felt when starting from a standstill or climbing a hill. In Appendix E you can know the full specification of your motor.

6.1.2 Li-Ion Battery

The battery of your electric tricycle is based on Li-Ion technology. Li-Ion batteries were introduced to the market more than 30 years ago and since then have evolved to be present in almost any application requiring a portable power source; they can be found in many devices across a wide range of industries such as: consumer, telecom, industrial, medical, automotive, etc. Mobility devices such as your new electric tricycle benefit from this technology due to its low weight, small size, high power and longer life cycle compared to other battery technologies. Later in this chapter, a complete section is devoted to explain the use and care of your Li-Ion battery.

6.1.3 Pedal Sensor

Your tricycle is equipped with a pedal assist sensor which detects and measures the pedal crank rotation (cadence) and in some cases the pedal pressure (torque). Based on this detection, the bike electric system naturally combines the motor's effort with the rider's.

Refer to Appendix E to know the specific characteristics of the sensor included in your bike model.

6.1.4 Display And Throttle

Your tricycle is also equipped with a display (User Interface) and a throttle. The display is based on LCD technology and is the main interface device between you and the bike system. Later in this chapter, complete instructions of your display are provided.

Your bike is also equipped with a throttle. Like on a motorcycle, throttles are designed to let the user apply 0-100% of the motor's power at will. Your bike is configured to allow the throttle to act independently of the pedal assist sensor; therefore it is possible to activate the bike by pressing the throttle.

6.1.5 Charger

Along with your bike, you received a charger unit which is compatible with the Li-Ion battery installed in your bike.

WARNING: Do not use the charger unit to charge other Li-Ion batteries than the specified one. Using a non-approved charger is dangerous and might result in fire.

6.2 Using Your Bike

Your new tricycle is categorized as a Class II Electric Bicycle; this means that the electric assistance is obtained in either of the following ways:

- PAS (Pedal Assist) mode. In this mode the bike motor will be activated upon detection of a crank rotation. The amount of power will depend on the assistance level configured.
- Throttle mode. In this mode the bike motor will be activated upon throttle activation, it is not necessary to have a crank rotation. This mode is always enabled; therefore, whenever the system is on, a throttle action will activate the bike motor.

Your brake levers incorporate a cutoff switch, whenever the brake is activated, the motor power will be interrupted. These switches are a safety feature designed to prevent the motor from accidentally engaging and causing injury.

WARNING: You should check the operation of your brake inhibitor switches before every ride. While riding slowly in a controlled environment (like a driveway), engage the motor, then squeeze each brake in turn. The motor should lose power immediately and remain off as long as a brake lever is depressed.

6.2.1 Display Controls

Your bike is equipped with a LCD display.



The display incorporates the following functions:

- Speed display
- Battery capacity indication
- Assistance level setting
- Lighting system activation
- Trip distance and total distance
- Time display for single journeys.
- Walk assistance mode
- Indication of error messages.

Figure 22 shows the display details.

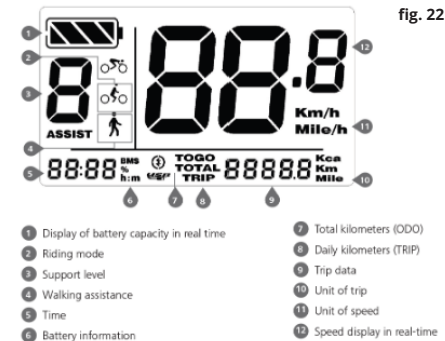

Switching The System On/Off

Press and hold power button (>2S) on the display to turn on the system. Press and hold power button (>2S) again to turn off the system. If the "automatic shutdown time" is set to 5 minutes (it can be reset with the "Auto Off" function, See "Set Auto Off"), the display will automatically be turned off within the desired time when it is not in operation.

Selection Of Support Levels

When the display is turned on, press the plus or minus (<0.5S) button to switch to the support level, the lowest level is 0, the highest level is 5 (the

amount of support level can be set). When the system is switched on, the support level starts in level 1. There is no support at level 0.

Headlights / Backlighting

Hold the plus (>2S) button to activate the frontlight and taillights. Hold the plus (>2S) button again to turn off the frontlight. The brightness of the backlight can be set in the display settings "Brightness".

Walk Assistance

The Walk assistance can only be activated with a standing pedelec. Activation: Press the minus button until the person symbol appears. Next hold down the minus button whilst the person symbol is displayed, now the Walk assistance will activate. The person symbol will blink and the pedelec moves approx. 5 km/h. After releasing the minus button, the motor stops automatically and switches back to level 0.

Reset Mileage

When HMI power on, at the single trip interface press and hold power button and minus button synchronously for 3 seconds to reset TRIP and exit.

Selection Mode

Briefly press power button (0.5s) to view TRIP or ODO.

Battery Capacity Indication

The battery capacity is displayed in real time as 100% to 0%.

Selection Of Unit In Km/Miles

When the system is on, press and hold plus and minus for 2 seconds to the setting interface, and then briefly press (<0.5S) plus or minus to select "Km/h" or "Mile/h". Press and hold plus and minus button together to save and exit to the main interface. Or press (<0.5S) power to save and enter next item "Set display brightness".

Set Display Brightness

When the system is on, press and hold plus and minus for 2 seconds to the setting interface, repetitively press (<0.5S) power until the brightness (bLt) interface (as below), and then press plus to increase or minus to reduce (brightness for 1-8). Press and hold and button together to save and exit to the main interface. Or press (<0.5S) power to save and enter next item "Set Clock".

6.2.2 Battery Controls

On-Off Switch

Your battery incorporates an On-Off switch which cuts the battery output power. This switch is located next to the charging port and acts as a master system switch; in order to be able to turn on the display and the bike, the switch must be in the on position.

fig. 23

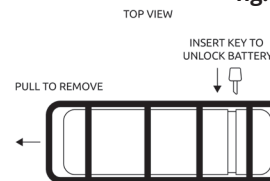
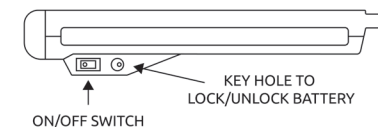

fig. 24



Capacity Gauge

Your battery incorporates a gauge that indicates remaining battery charge. The gauge is made of 5 LEDs each representing a 20% of charge. To activate it the "Voltage" button needs to be pressed once.

This battery charge gauge is based on a simple measurement of battery voltage. This voltage is translated directly to what is shown on the display; for example, the gauge may call the battery full above 48V, and near empty around 40V. This type of gauge is generally accurate, but because a battery's voltage fluctuates based on its load (how much energy is being drained from it at a given moment), the gauge will also not always be stable; it will indicate less charge remaining while the bike is accelerating or climbing a hill, and more when the bike is stopped or being ridden at a steady pace on flat ground.

fig. 25

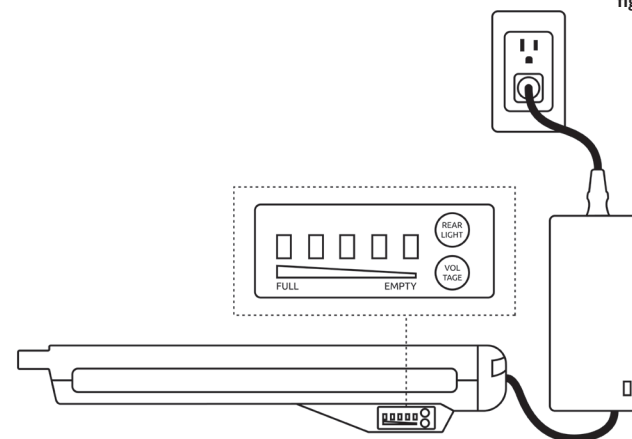

Rear Light

Your battery is equipped with an integrated rear light. The light has 2 different activation modes which are obtained by pressing the "Rear Light" button. In the first activation mode, the light will stay steady on; in the second activation mode, the light will blink twice per second. To switch off the light, press the button until the light off mode is reached.

6.3 Battery Care And Safety

fig. 26

Type: Lithium-ion Battery
Model No: INT-48V-CA
Rating: 46.8V / 13Ah / 608Wh
Charging Instructions: USE SPECIFIED CHARGER ONLY
Warning: RISK OF FIRE OR EXPLOSION, AVOID MECHANICAL SHOCK
Do not: DISASSEMBLE; SHORT CIRCUIT; INCINERATE; EXPOSE TO TEMPERATURES ABOVE 60 °C; EXPOSE TO LIQUID, VAPOR, OR RAIN;

 **WARNING:** Failure to properly use, charge, and store your battery as instructed will void the warranty and may cause a hazardous situation. Before using your battery for the first time, read this section of the manual in its entirety. If you have any questions about this battery or its usage, please contact us.

Proper maintenance and care of batteries will maximize their lifespan and capacity. The warranty of your new battery is valid from the date of purchase only if properly cared for.

As mentioned before, your bike is equipped with a Li-Ion battery. Li-Ion is a very user friendly type of battery when cared for properly. All Li-Ion batteries are subject to degradation, this is a natural behavior and cannot be avoided. Every time the battery is discharged and subsequently recharged, its relative capacity decreases by a small percentage. You can maximize the life of your battery by following the instructions in this guide.

6.3.1 Initial Actions

Batteries are not shipped with a full charge. You should charge your battery for 4-6 hours as soon as possible after you receive it.

NOTE: The rated output capacity of a battery is measured at 77°F (25°C). Any variation in this temperature will alter the performance of the battery. High temperatures allow the battery to deliver more charge but reduce overall battery life & run time; low temperatures reduce the battery ability to deliver charge.

6.3.2 Battery Charging

Please follow these instructions to charge your battery:

1. Connect the charger connector to the battery charging port.
2. Connect the charger to the mains outlet.
3. The charging process is now initiated. While the charging process is active, the charging indicator light shows a red color; once the charging process is finished and the battery is fully charged, the charging

indicator light will show a green color.

4. Once the battery is fully charged (Charging indicator light green), unplug the charger from the mains and then from the battery.
5. Your battery is ready to use; store your charger.

 **CAUTION:** The battery should not be charged if the ambient temperature is below 32°F (0°C) or above 113°F (45°C). Doing so might cause irreversible damage to the battery or could cause a fire resulting in severe injury or death, and property damage.

 **CAUTION:** If the battery charger connector is plugged to the battery while already connected to the mains, a spark might happen. Always connect the charger to the battery before connecting it to the mains.

 **WARNING:** Improper use of the battery charger can cause a fire resulting in severe injury or death, and property damage.
WARNING: The battery charger supplied with this battery is for INDOOR use only.

 **WARNING:** Avoid any contact with water or other fluids while charging the battery. If the battery, charger or any connections become wet, immediately unplug the charger and thoroughly dry all components prior to charging the battery.

 **WARNING:** Use only the battery charger supplied with this battery. If you use any other battery charger, you will void the warranty, you may damage the battery, and you could cause a fire resulting in severe injury or death, and property damage.

 **WARNING:** Never charge a battery continuously for longer than 12 hours.

 **WARNING:** Charge your battery during the day and only in rooms which have a smoke or a fire detector; but not in your bedroom. During the charging process, place the battery on a non-flammable surface such as metal, ceramic, or glass.

 **WARNING:** There is high voltage inside the charger, do not attempt to open it.

6.3.3 Charger FCC Information

The charging equipment provided with your bike has been tested and found to comply with the limits for a Class B digital device, pursuant to Part 15 of the FCC Rules. These limits are designed to provide reasonable protection against harmful interference in a residential installation.

This equipment generates, uses and can radiate radio frequency energy

and, if not installed and used in accordance with the instructions, may cause harmful interference to radio communications. However, there is no guarantee that interference will not occur in a particular installation.

6.3.4 Battery Storage

If you will not use your battery for a period longer than 2 months, follow these instructions for storage:

- Remove the battery from the bike.
- Lithium-ion batteries are best stored at a 30% charge level. During long term storage, recharge your battery to 30% every 90 days. Determine charge level using either the built-in charge indicator on the battery pack, or the battery gauge on the bike. Batteries slowly self-discharge when left unused for a long period of time; if the battery cells are allowed to reach a critically low voltage, their lifespan and capacity will be permanently reduced.
- Always disconnect your charger from the wall outlet and battery before storing the battery.
- Avoid storing your battery in extreme temperatures, whether hot or cold. Batteries are best kept in a cool, dry place. The recommended storage temperature for Li-Ion batteries is between 32–77°F (0–25°C).
- Do not allow your battery to accumulate condensation, as this could cause corrosion or a short-circuit.

6.3.5 Battery Shipping And Transport

Lithium-ion batteries are subject to many regulations, and are often considered dangerous material by carriers. Be sure to check for relevant laws, and ask the carrier for approval prior to shipping a lithium-ion battery, or transporting it by air.

6.3.6 Battery Disposal

Be friendly to the environment! Be sure to recycle your old batteries at a local battery-recycling center. Do not throw them in the garbage! Check www.Call2Recycle.org for more information on free battery drop off locations.

6.3.7 Additional Battery Remarks

- Your battery does not require a break-in period, therefore, you will enjoy its full performance since the first charge.
- It is normal that the battery will become warm to the touch during the recharging process. This is because of the pack's internal resistance and losses in energy conversion efficiency from electric energy to chemical energy.
- Average battery life depends on use and conditions. Even with proper care, rechargeable batteries do not last forever. Conservatively, a Li-Ion battery will last about 500–750 cycles. A partial charge/discharge counts fractionally against those numbers; running the battery down halfway then recharging it completely uses up one half of a charge cycle. "End of useful life" refers to the point at which a battery can no

longer supply 70% of its original rated capacity in ampere hours. After this point, the aging process will accelerate and the battery will need to be replaced.

- Li-Ion batteries do not have any memory. Partial discharge/charge cycles will not harm the battery's capacity or performance. It is OK to charge the battery as often as is convenient.

6.3.8 Battery Warnings

 **WARNING: Use only the battery provided with your bicycle. Even if it is physically possible to connect another type of battery, it is dangerous and potentially damaging to do so.**

 **WARNING: DO NOT use this battery with any other vehicle or appliance. Use of this battery with any other product will void the warranty, and may create a hazardous condition that could cause a fire resulting in severe injury or death, and property damage.**

 **WARNING: Never disassemble the battery or open the battery case. There is a risk of electric shock and damage to the battery.**

 **WARNING: Never short circuit the discharge terminals of the battery. A short circuit will damage the battery and could cause a fire resulting in severe injury or death, and property damage. When handling the battery outside the bicycle, be aware of conductive materials that may short the battery terminals, such as coins, nails, etc.**

 **WARNING: Never crush or puncture the battery. A punctured or crushed battery could catch fire or explode, which could lead to serious injury or death.**

 **WARNING: Protect the battery from water or other moisture. If the battery becomes wet from rain during use, dry it as soon as possible. Remove the battery from the electric bicycle before washing the bicycle. Clean the battery with a dry or slightly moist rag; do not submerge or spray with pressurized water.**

 **WARNING: Keep the battery away from excessive heat (104°F or higher) and/or open flames. Avoid long term exposure to direct rays from the sun.**

CAUTION: Protect the battery from materials that may contaminate the charge port or the output port, such as dirt and sand; the ports may be difficult or impossible to clean out.

CAUTION: To avoid damage to the battery, never subject it to intense physical shock or severe vibration.

6.4 Riding An Electric Bike

6.4.1 Safety

 **WARNING: Because electric bikes are faster and heavier than normal bicycles, they require extra caution and care while riding. Failure to heed the following safety instructions could lead to a crash, injury, or death.**

- Before your first ride, familiarize yourself with this manual.
- Before traveling on streets or around others, practice riding in a safe area away from pedestrians and traffic (such as a driveway or empty parking lot).
- Always use the lowest assist setting until you are comfortable with the bike and feel confident controlling the electric assist.
- When mounting your bike, make sure not to step on the pedals until you are sitting on the saddle and gripping the handlebars tightly. If you apply pressure to the pedals, or move them, the motor assistance might switch on suddenly and result in an uncontrolled start of your bike.
- Always wear a helmet, closed-toe shoes, and eye protection when riding.
- Never ride at a speed outside your comfort zone, or that you feel may be unsafe for the given conditions.
- Keep your hands on the brake levers, and remember that they will always slow or stop the bike if pulled. Even on bikes without brake inhibit switches (see “Brakes” on Section 5.3), the brakes are always more powerful than the motor.
- Heavy electric bikes like your tricycle take longer to slow down; leave extra space for stopping safely.
- Electric bikes are considerably heavier than normal bicycles. For this reason parking, pushing, lifting and carrying the bike is more difficult. Bear this in mind when loading your bike into a van and unloading it, or when mounting it on a bicycle carrier system.
- Remember that all the information in this manual referring to bicycle safety also applies to your electric bike.
- Be prepared to slow down sooner than usual when approaching turns.
- Avoid distractions when riding, and maintain your focus on the road in front of you. Riding at speed means you will have less time to react to any sudden changes in your riding environment.

 **WARNING: Always ride defensively. Any cyclist is at risk when sharing the road, so it is important to dress and ride responsibly. Any collision with another vehicle or pedestrian can cause serious injury or death to all parties involved.**

Pedestrians and vehicles in your riding vicinity may have difficulty judging how quickly you are riding, and you will have less time to judge the speed and direction in which they are traveling.

- Dress to be seen. Wear bright colors and reflective gear.

- When riding, obey all traffic rules and provide clear signals to others sharing the road.

 **WARNING: Make no modifications to the bike's electrical system that are not explicitly approved by the manufacturer.**

6.4.2 Legality

In the United States, federal legislation defines electric bikes as “a two- or three-wheeled vehicle with fully operable pedals and an electric motor of less than 750 watts (1h.p.), whose maximum speed on a paved level surface, when powered solely by such a motor while ridden by an operator who weighs 170 pounds, is less than 20 mph.” Your tricycle is consider an electric bike as per this definition.

However, local and state regulations vary, and it is your responsibility to ensure your bike is legal in your particular area before riding it on public roads. If you're unsure, ask your bicycle dealer for more information about local laws and regulations.

6.4.3 Range

- The range of your electric bicycle varies greatly depending on many factors, the most important are:
- Battery state-of-charge and state-of-health. A fully charged battery will provide the greatest range; additionally, a new battery will always hold more charge than a one with years of use.
- Mode setting (the bike will use less power in the pedal assist Mode due to the required contribution of the rider).
- Tire inflation pressure.
- Rider weight (it takes more energy to accelerate a heavier person).
- Terrain (road surface and hills; traveling on a soft surface, such as dirt or gravel, or climbing a hill uses energy faster).
- Lots of starts and stops (full power from a standing start draws the most amperage from the battery).
- The speed at which you travel, and local wind conditions (air resistance increases exponentially with speed).
- Adjustment of the wheel bearings and brakes (tight bearings or a dragging brake shoe will adversely affect range).
- Your bike is more sensitive to the mentioned factors due to the low vehicle weight in relation to the rider weight. Cars and other forms of vehicles are less sensitive to the above mentioned factors due to the large vehicle weight in comparison to the rider.

To maximize your bicycle range we suggest the following:

- Fully charge your battery before each ride.
- Ride in pedal assist mode and pedal!
- Enjoy the health benefits available from cycling. Every watt of power that you provide is one watt less that the battery has to provide. Make your bicycle a true human/electric hybrid!

- Check your tire pressure regularly and inflate the tires to the maximum pressure printed on the tire sidewall.
- Have your bicycle serviced periodically to ensure that the bearings turn freely and the brakes do not rub the rims (or rotors, for a disc brake) when they are not applied.
- Minimize the weight that you carry.
- Ride at slower speeds.
- Accelerate gently. Assist the system by pedaling as you accelerate to your cruising speed.

As your battery ages, it will gradually lose capacity. With proper care and maintenance, your Li-ion battery will retain up to 70% of its capacity for at least 500 discharge/ recharge cycles. As capacity diminishes, you will notice a gradual drop-off in maximum range capability. When range falls to an unacceptable level, contact your authorized dealer for information regarding purchasing a replacement battery.

6.4.4 Hills

If you encounter a hill that causes the speed of your bicycle to drop below 7 miles per hour (11 kilometers per hour) on electric power only (throttle mode with no pedaling) with the throttle fully applied, PEDAL to assist the bicycle up the hill. Failure to do so could overstress the motor and controller, possibly causing those components to overheat. Further, failure to pedal up steep hills to assist the bicycle will overstress the battery, reducing its capacity and shortening its useful life.

 **WARNING: Extra care should be exercised when descending a steep hill. Your tricycle is considerably heavier than a regular bicycle and you may lose control specially in curvy descents. Brake gently and evenly at the beginning of the descent and do not allow the tricycle to reach a speed beyond the one that you feel comfortable and confident in maneuvering. This warning is specially important when traveling with children inside the cargo box.**

 **WARNING: Turning left or right on a steep hill can cause your electric tricycle to tip over. You must slow your bike nearly to a stop before making a turn on a slope. Greatly reducing the speed of your trike before turning on flat terrain is also recommended. Especially with kids or cargo, take turns with extreme caution, applying the brakes consistently, at the lowest possible speed. See Section 1.2 for more information on tipping risks and how to prevent them.**

Weather Conditions

Your electric bike is built with components that are sealed against dust and water, and can safely operate in most weather conditions. To ensure the longest life of your components, however, you should avoid riding in wet weather if possible. Please refer to Section 3.5 to read more about wet weather riding.

 **WARNING: To avoid risk of electric shock and property damage, never submerge any of the bike's electrical components in a liquid.**

 **WARNING: Electric bikes are faster and heavier than normal bikes. When riding in wet weather, you should use extra caution. You are more likely to fall from a wet road surface when traveling at high speed. Heavy electric bikes also take longer to slow down, and the required stopping distance in wet weather is even greater; be sure to leave ample room for stopping, and brake gently and evenly to avoid falling.**

 **WARNING: Wet weather impairs traction, braking and visibility, both for the bicyclist and for other vehicles sharing the road. So the risk of an accident is dramatically increased. Under wet conditions, the stopping power of your brakes (as well as the brakes of other vehicles sharing the road) is dramatically reduced and your tires don't grip nearly as well. This makes it harder to control speed and easier to lose control. So make sure to ride more slowly and apply your brakes earlier and more gradually than you would under normal, dry conditions**

6.5 Electric Bike Care

Like any bicycle, you should take care of your electric bike to extend its life and keep it operating smoothly.

In addition to following the instructions in "Service" on Section 8, mind the following instructions for keeping your electric bike like new.

- Maintain your batteries as described in "Battery care & safety" on Section 6.3. This is especially important when storing batteries unused for long periods of time.
- Periodically inspect your bike's wiring and electrical connectors for damage. Frayed or heat-damaged wires, loose plugs, or bad connections could eventually cause damage to the system.
- Store your bike indoors. A bike left outside in the weather will deteriorate very quickly. Never cover a stored bike with plastic as condensation buildup could cause damage to electrical components. Battery packs especially should be kept in a temperature controlled, dry environment.
- Review all component manuals and exercise caution before applying any chemicals, paint, or cleaning agents to the electrical components of the bike.

6.6 Electric bike service

If you have any questions, issues, or concerns, please contact your dealer, or the Integral Electrics customer care department using the contact information provided at the beginning of this manual. Do not ride a bike you suspect may not be functioning fully.

 **WARNING:** There are no user serviceable elements incorporated into the motor, motor controller, battery, battery charger, throttle, or wiring harness of your electric bicycle.

DO NOT ATTEMPT TO DISASSEMBLE OR ADJUST ANY OF THESE COMPONENTS.

Doing so may cause extensive damage to these components, will void your warranty, and may cause a hazardous condition. If you cannot resolve a problem with your bicycle, contact your authorized dealer or Integral Electrics using the contact information provided at the beginning of this manual.

7. CARGO

Carrying a load and riding a medium/long-wheelbase bike both require getting accustomed to. You should practice maneuvering and braking on a flat, hazard- and traffic-free street with and without a load before going out onto a public or busy street.

The cargo box is designed to transport children and goods, carrying a seated passenger or heavy load involves risks, foremost of which can be decreased stability, decreased braking power and increased stopping distance. Always make sure you have at least two well-adjusted brakes.

7.1 The Front Box

Your tricycle incorporates a front box used to transport children and goods such as boxes, baskets and cartons. Please follow these instructions when using the front box.

- It is essential to position the load evenly, and to securely attach it to the box using a rope, cam straps or some type of bungee cord.
- Standing, kneeling or jumping on the box while the bike is moving or stopped can easily lead to loss of control of the bike, destroyed rims, a destroyed bike frame, severe injury or death.
- If you are carrying passenger or cargo, secure all loose ends such as dangling straps and loose fitting clothing on passengers so that nothing can get caught in your wheels.
- Make sure you don't surpass the Max Gross Vehicle Weight with the total load on your bike (Appendix B).

 **WARNING:** The load(s) attached or placed on the box of the cargo tricycle must be securely fastened. Check that no edges or parts of the load can come into contact with moving parts of the tricycle. You could lose control of the tricycle and fall.

 **WARNING:** A combination of factors – including the structural rigidity of the frame, individual component strength, steering behavior, and weight distribution – affect the bike's handling. When

riding with a heavy load, the bike will require more effort to balance and more time to brake.

 **WARNING:** There is a strong relationship between the weight of the rider and the amount of cargo the rider can comfortably balance and ride with. Most riders can comfortably carry 80% of their weight. You should determine if you are comfortable carrying that much weight.

 **WARNING:** Riding with passenger(s), cargo, or both affect the Pedelec's weight, balance, center of gravity, and handling. **WARNING:** Do not to exceed the maximum carrying capacity, which includes rider weight, passenger weight, rear rack, Child Seat(s) and any other accessories. Check Appendix B for the maximum weight limit.

7.1.1 Passengers And Children

 **WARNING:** The user of this product acknowledges both an understanding and an assumption of the risks involved in cycling, cycling with cargo, and cycling with a passenger, especially with children.

 **WARNING:** Never leave a child unattended on the back of a tricycle.

- Children are the most vulnerable individuals in case of an accident, we urge you to follow these instructions when traveling with children.
- Carrying passengers by bicycle is subject to limitations and regulations in most countries. Check local traffic and regulations to learn more and comply with the law.
- Children traveling in the cargo box should always do so using the incorporated seat belts. The belts should never be unlocked while the vehicle is stopped or in movement. Additionally, children should always use an appropriate helmet for head protection.
- Passenger should remain seated while bicycle is in motion.
- Children under the age of four should not ride on the tricycle as a passenger unless it is equipped with an approved Child Seat accessory.
- Children – regardless of age – should be strong enough to hold up their head and withstand the bouncing that comes with riding.
- Never allow children to climb onto the Pedelec by themselves unless an adult is steadying the bike.
- Always hold onto your Pedelec when a child is in the Child Seat to prevent the Pedelec and child from falling over.
- Periodically check on your child while riding as they may fall asleep.
- Don't let their head strain excessively to one side.
- Practice, practice, practice: Rider size and strength will affect how easily a loaded tricycle can be handled. Always practice in an open, car-free area before carrying a passenger.

When using a Child Seat accessory, please make sure that it meets the following requirements:

- The Child Seat meets the EN 14344, European Standard for Child's Seats for Tricycles.
- The seat is designed so that any contact between the child's feet and the wheel is impossible.
- The child's fingers are protected against being caught in any part of the saddle (such as the springs of suspension saddles).
- The child seat is firmly secured to the cargo box.
- Always thoroughly check the balance. Mount the Child Seat and load it with a dummy weight equivalent to that of the child. Test ride in various road conditions including riding uphill and make sure the tricycle is stable.

WARNING: Never park and leave children on the bike unattended. Wriggling kids can upset the balance of the bike and cause it to fall over, causing serious injury.

WARNING: Do not mount or attach the Child Seat to the seat post, or any other part of the frame that is not approved for child seat mounting.

WARNING: Never, ever leave children unattended on the back of the Pedelec, even if it is on the kickstand. Wriggling children can upset the balance of the bike and a fall may result in serious injuries.

WARNING: Make sure that your child always wears an approved bicycle helmet when riding.

WARNING: Do not allow children to play on, or around a parked tricycle, as this poses a serious injury risk.

WARNING: Handholds: Ensure the rear passenger has something to hold during the ride. Whenever the bike is in motion, passengers not in a Child Seat must keep a grip on something stationary.

No warning is a substitute for good judgment. Always use good judgment. If you have reason to suspect that your own judgment isn't great, share your plans with somebody you respect, and ask for a second opinion.

7.2 Additional Cargo Considerations

WARNING: Always make sure you have at least two well-adjusted brakes. Under severe loads (as when carrying a passenger or cargo) at high speed a very strong front brake can lead to failure of the bike.

WARNING: Keep feet and hands away from moving wheel and chain. Contact with moving parts can result in serious injury.

WARNING: To reduce the risk of injury, use wheel-skirts, approved side bags, sideloader feet support and/or approved child seat when carrying passengers or children. Instruct passengers to keep feet and limbs outside of the wheel well and away from moving parts.

7.2.1 Pre-Ride Checklist

- Ensure straps cannot get caught in the wheels.
- Ensure bags, boxes or any other item are in a position where they cannot be caught in the spoke.
- Double-check your load for security and stability.
- Check that your brakes are well adjusted.
- Check to see that your wheels are securely fastened.
- Check that your helmet and passenger's helmets are securely fastened.
- Check that no components or frame members are cracked or broken (in general, if at any time you notice a crack or bend in your bike, stem, forks, or bars of your tricycle, stop riding immediately; take your bike to your local bike shop and have them inspect it)
- Check that your bike is equipped with the proper passengers accessories (child seat, foot pegs, handle bar, side bags, etc.).

7.2.2 Kickstand and Parking Brake

Your tricycle does not incorporate a traditional bicycle kickstand, instead, the brake levers have a blocking function which will activate the wheel brakes and keep the bike stopped (fig. 27). There are a few important points to take into consideration when using this function.

- The brake function is not designed for heavy loading, passenger loading or commercial applications.
- The user should always hold on to the bike when loading it.

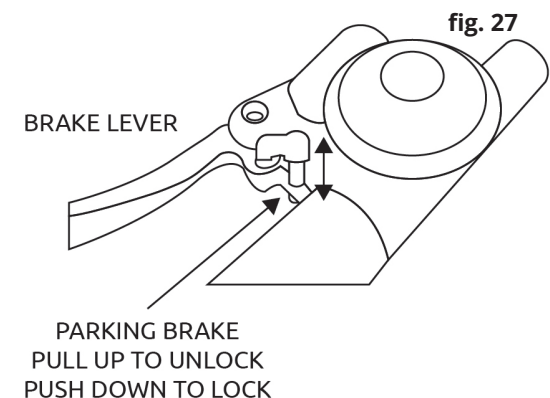

7.2.3 Maximum Payloads

Please refer to Appendix B to know the weight limits of your bike.

8. SERVICE



WARNING: Technological advances have made bicycles and bicycle components more complex, and the pace of innovation is increasing. It is impossible for this manual to provide all the information required to properly repair and/or maintain your tricycle. In order to help minimize the chances of an accident and possible injury, it is critical that you have any repair or maintenance that is not specifically described in this manual performed by your dealer. Equally important is that your individual maintenance requirements will be determined by everything from your riding style to geographic location. Consult your dealer for help in determining your maintenance requirements.



WARNING: Many tricycle service and repair tasks require special knowledge and tools. Do not begin any adjustments or service on your tricycle until you have learned from your dealer how to properly complete them. Improper adjustment or service may result in damage to the tricycle or in an accident which can cause serious injury or death.

If you want to learn to do major service and repair work on your bike:

- a. Ask your dealer for copies of the manufacturer's installation and service instructions for the components on your bike, or contact the component manufacturer.
- b. Ask your dealer to recommend a book on tricycle repair.
- c. Ask your dealer about the availability of tricycle repair courses in your area.

We recommend that you ask your dealer to check the quality of your work the first time you work on something and before you ride the bike, just to make sure that you did everything correctly. Since that will require the time of a mechanic, there may be a modest charge for this service.

We also recommend that you ask your dealer for guidance on what spare parts, such as tires, inner tubes, light bulbs, batteries, Patch Kit, lubricants etc. it would be appropriate for you to have once you have learned how to replace such parts when they require replacement.

8.1 Service Intervals

Some service and maintenance can and should be performed by the owner, and require no special tools or knowledge beyond what is presented in this manual.

The following are examples of the type of service you should perform yourself. All other service, maintenance and repair should be performed in a properly equipped facility by a qualified tricycle mechanic using the correct tools and procedures specified by the manufacturer.

8.1.1 Break-In Period

Your bike will last longer and work better if you break it in before riding it hard. Control cables and wheel spokes may stretch or "seat" when a new bike is first used and may require readjustment by your dealer. Your Mechanical Safety Check (Section 2.4) will help you identify some things that need readjustment. But even if everything seems fine to you, it's best to take your bike back to the dealer for a checkup. Dealers typically suggest you bring the bike in for a 30 day checkup. Another way to judge when it's time for the first checkup is to bring the bike in after three to five hours of hard off-road use, or about 10 to 15 hours of on-road or more casual off-road use. But if you think something is wrong with the bike, take it to your dealer before riding it again.

8.1.2 Before Every Ride

Mechanical Safety Check (Section 2.4)

8.1.3 After Every Long Or Hard Ride

If the bike has been exposed to water or grit; or at least every 100 miles: Clean the bike and lightly lubricate the chain's rollers with a good quality bicycle chain lubricant. Wipe off excess lubricant with a lint-free cloth. Lubrication is a function of climate. Talk to your dealer about the best lubricants and the recommended lubrication frequency for your area. Squeeze the front brake and rock the bike forward and back. Everything feel solid? If you feel a clunk with each forward or backward movement of the bike, you probably have a loose headset. Have your dealer check it.

Lift the front wheel off the ground and swing it from side to side. Feel smooth? If you feel any binding or roughness in the steering, you may have a tight headset. Have your dealer check it.

Grab one pedal and rock it toward and away from the centerline of the bike; then do the same with the other pedal. Anything feel loose? If so, have your dealer check it.

Take a look at the brake pads. Are they worn or not hitting the wheel rim squarely? Time to have the dealer adjust or replace them.

Carefully check the control cables and cable housings. Any rust? Kinks? Fraying? If so, have your dealer replace them.

Squeeze each adjoining pair of spokes on either side of each wheel between your thumb and index finger. Do they all feel about the same? If any feel loose, have your dealer check the wheel for tension and trueness.

Check the tires for excess wear, cuts or bruises. Have your dealer replace them if necessary.

Check the wheel rims for excess wear, dings, dents and scratches. Consult your dealer if you see any rim damage.

Check to make sure that all parts and accessories are still secure, and tighten any that are not.

Check the frame, particularly in the area around all tube joints; the handlebars; the stem; and the seatpost for any deep scratches, cracks or discoloration. These are signs of stress-caused fatigue and indicate that a part is at the end of its useful life and needs to be replaced. See also Appendix C.

8.1.4 Disc Brakes

Disc brakes require a different set of inspection steps. Check for these issues before every ride:

- Pads rubbing on rotors.
- Worn out pads (which can lead to over-extended pistons).
- Pistons that are stuck and/or won't retract fully.
- Disc rotors that are bent and need straightening by the dealer.
- Hydraulic brakes that feel "sponge-y" and/or levers that can be depressed all the way to the grips without generating adequate stopping power (due to trapped air and/or leaks).

 **WARNING: Like any mechanical device, a tricycle and its components are subject to wear and stress. Different materials and mechanisms wear or fatigue from stress at different rates and have different life cycles. If a component's life cycle is exceeded, the component can suddenly and catastrophically fail, causing serious injury or death to the rider.**

Scratches, cracks, fraying and discoloration are signs of stress-caused fatigue and indicate that a part is at the end of its useful life and needs to be replaced. While the materials and workmanship of your tricycle or of individual components may be covered by a warranty for a specified period of time by the manufacturer, this is no guarantee that the product will last the term of the warranty. Product life is often related to the kind of riding you do and to the treatment to which you submit the tricycle. The tricycle's warranty is not meant to suggest that the tricycle cannot be broken or will last forever. It only means that the tricycle is covered subject to the terms of the warranty. Please be sure to read Appendix B, Intended Use of your tricycle and Appendix C, The lifespan of your bike and its components.

8.1.5 As Required

If either brake lever fails the Mechanical Safety Check (Section 2.4), don't ride the bike. Have your dealer check the brakes. If the chain won't shift smoothly and quietly from gear to gear, the derailleur is out of adjustment. See your dealer.

Every 25 (hard off-road) to 50 (on-road) hours of riding: Take your bike to your dealer for a complete checkup.

8.1.6 If Your Tricycle Sustains An Impact

First, check yourself for injuries, and take care of them as best you can. Seek medical help if necessary. Next, check your bike for damage. After any crash, take your bike to your dealer for a thorough check. Carbon composite components, including frames, wheels, handlebars, stems, cranksets, brakes, etc. which have sustained an impact must not be ridden until they have been disassembled and thoroughly inspected by a qualified mechanic.

See also Appendix C, Lifespan of your bike and its components.

 **WARNING: A crash or other impact can put extraordinary stress on tricycle components, causing them to fatigue prematurely. Components suffering from stress fatigue can fail suddenly and catastrophically, causing loss of control, serious injury or death.**

APPENDIX A: TEACHING YOUR CHILD THE RULES AND MODELING THEM YOURSELF

In addition to The Basics, Riding Safely, Off Road Safety, Wet Weather Riding, Night Riding, Bicycling in Traffic and Downhill, Stunt and Competition Biking, kids need to be taught and to have frequently reinforced the following rules and lessons which adults are already expected to know. We urge you to take the time to familiarize yourself with these rules and to teach them to your child as you ride together.

Rules

- No playing in the road or in the street.
- No riding on busy streets.
- No riding at dawn, dusk or at night.
- Stop for all STOP signs.
- Ride on the right of traffic.

Lessons

The lessons that follow relate to some of the most common real situations that children encounter when riding their bikes. Go over these situations with your child and make sure the lesson objective is accomplished.

Driveway Rideout

When a youngster rides out of the driveway and is struck by a car, that is called a rideout accident.

What Can You Do?

First, realize the danger of your own driveway. If there are obstructions to the view of passing motorists (like bushes or trees), trim them back. You might park your car in front of the driveway, if local ordinance permits. This way, your child can't use the driveway as a launching pad. But the most important thing you can do is teach your child about driveway safety. Take your child outside to the driveway and have him/her practice the following steps:

1. Stop before entering the street.
2. Look left, right and left again for traffic.
3. If there's no traffic, proceed into the roadway.

Running A Stop Sign

Car/bike crashes can happen when a cyclist runs a stop sign. Most cyclists who get hit riding through stop signs know that they were supposed to stop. They just thought it would be OK this time; or they may have been distracted. The thing to impress upon your child is that while he/she may not get hit every time, running stop signs will eventually result in an accident.

What Can You Do?

Take your child to a stop sign near home. Explain what it means by emphasizing the following points:

- a. Stop at all stop signs, regardless of what is happening.
- b. Look in all directions for traffic.

- c. Watch for oncoming cars making left turns.
- d. Watch for cars behind you making right turns.
- e. Wait for any cross traffic to clear.
- f. Proceed when safe.

In order to make this lesson stick, you may have to change your own driving habits. If you creep through intersections controlled by stop signs, you are showing your child that you don't really believe what you preach. For your child's sake, stop at stop signs.

Turning Without Warning

Another major accident type involves cyclists who make unexpected left turns. They neither look behind for traffic, nor do they signal. The key factor here is neglecting to look to the rear. If the cyclist had looked, he/she would have seen the danger coming up from behind.

What Can You Do?

Of course, you ought to teach your child not to ride across busy streets - at least until the child has had some advanced training and is old enough to understand traffic. But in the meantime, for residential street riding, you can teach your child to always look and signal before turning left. A big part of this lesson is teaching the child how to look to the rear without swerving.

Take your child to a playground or a safe area away from traffic or obstructions to practice riding along a straight line while looking behind. Stand alongside and hold up a different number of fingers on your hand after the child rides by. Call his/her name. After 15 minutes of practice, a ten year old should be able to look behind his/herself and identify how many fingers you are holding up - without swerving.

Riding At Dawn, At Dusk Or At Night (See Also Section 3.6)

Most car/bicycle accidents happen at night where an overtaking car hits a bike. (An overtaking car is one that comes up from behind and passes the cyclist on the left.) These overtaking accidents can be very serious.

What Can You Do?

First, you should keep your youngster from riding at dawn, dusk or at night. It requires special skills and equipment. Few children have either. Secondly, make sure your child understands that if he/she gets caught out at dusk or after dark on a bike, the thing to do is to call you for a ride home. One suggestion is to have your child carry a cell phone, and as an added precaution, tape a phone number to the bike so that, in an emergency, an adult will be able to call home.

Following The Leader

There is increased risk of car/bike collision if children are following each other, because if the first one does something dangerous, those following may do it too.

What Can You Do?

Teach your child to always assess the traffic situation for him/herself. When a group is riding around, each cyclist should stop for stop signs; each cyclist should look to the rear before making left turns; and so on. One way to get the message across is to play a game with the child similar to 'Simon Says'. In this game, however, the emphasis should not be on doing what 'Simon Says', but rather have the child make a decision based on the situation. The child should learn to ignore what 'Simon Says'. Children need to learn to think for themselves to ride safely.

Summary

Teach your child early - the earlier the better. Learning skills such as looking and avoiding hazards takes time. Be prepared to repeat lessons until your child understands what you're trying to get across. Be patient. Your efforts will be rewarded, knowing that your child is aware of safe riding skills.

APPENDIX B: INTENDED USE OF YOUR BICYCLE

 **WARNING: Understand your bike and its intended use. Choosing the wrong bicycle for your purpose can be hazardous. Using your bike the wrong way is dangerous.**

No one type of bicycle is suited for all purposes. Your retailer can help you pick the "right tool for the job" and help you understand its limitations. There are many types of bicycles and many variations within each type. There are many types of mountain, road, racing, hybrid, touring, cyclo-cross and tandem bicycles.

There are also bicycles that have a mix of features. For example, there are road/racing bikes with triple cranks. These bikes have the low gearing of a touring bike, the quick handling of a racing bike, but are not well suited for carrying heavy loads on a tour. For that purpose you want a touring bike.

Within each of type of bicycle, one can optimize for certain purposes. Visit your bicycle shop and find someone with expertise in the area that interests you. Do your own homework. Seemingly small changes such as the choice of tires can improve or diminish the performance of a bicycle for a certain purpose.

On the following pages, we generally outline the intended uses of various types of bikes.

Note: Industry usage conditions are generalized and evolving. Consult your dealer about how you intend to use your bike.

General Purpose Riding

Your tricycle is referred to as "Condition 2".

Your tricycle is designed for riding on a paved surface, smooth gravel roads and improved trails with moderate grades where the tires do not lose ground contact.



Intended

For paved roads, gravel or dirt roads that are in good condition, and bike paths.

Not Intended

For off-road or mountain bike use, or for any kind of jumping. Some of these bikes have suspension features, but these features are designed to add comfort, not off-road capability. Some come with relatively wide tires that are well suited to gravel or dirt paths. Some come with relatively narrow tires that are best suited to faster riding on pavement. If you ride on gravel or dirt paths, carry heavier loads or want more tire durability talk to your dealer about wider tires.

Maximum Weight Limit

	lbs	kg
Rider	275	125
Luggage	397	180
Total	672	305

APPENDIX C: THE LIFESPAN OF YOUR BIKE AND ITS COMPONENTS

NOTHING LASTS FOREVER, INCLUDING YOUR BIKE.

When the useful life of your bike or its components is over, continued use is hazardous. Every tricycle and its component parts have a finite, limited useful life. The length of that life will vary with the construction and materials used in the frame and components; the maintenance and care the frame and components receive over their life; and the type and amount of use to which the frame and components are subjected. Use in competitive events, trick riding, ramp riding, jumping, aggressive riding, riding on severe terrain, riding in severe climates, riding with heavy loads, commercial activities and other types of non-standard use can dramatically shorten the life of the frame and components. Any one or a combination of these conditions may result in an unpredictable failure.

All aspects of use being identical, lightweight bicycles and their components will usually have a shorter life than heavier bicycles and their components. In selecting a lightweight bicycle or components you are making a trade

off, favoring the higher performance that comes with lighter weight over longevity. So, if you choose lightweight, high performance equipment, be sure to have it inspected frequently.

You should have your tricycle and its components checked periodically by your dealer for indicators of stress and/or potential failure, including cracks, deformation, corrosion, paint peeling, dents, and any other indicators of potential problems, inappropriate use or abuse. These are important safety checks and very important to help prevent accidents, bodily injury to the rider and shortened product life.

Perspective

Today's high-performance bicycles require frequent and careful inspection and service. In this Appendix we try to explain some underlying material science basics and how they relate to your bicycle. We discuss some of the trade-offs made in designing your bicycle and what you can expect from your bicycle; and we provide important, basic guidelines on how to maintain and inspect it. We cannot teach you everything you need to know to properly inspect and service your bicycle; and that is why we repeatedly urge you to take your bicycle to your dealer for professional care and attention.

 **WARNING: Frequent inspection of your bike is important to your safety. Follow the Mechanical Safety Check in Section 2.4 of this Manual before every ride. Periodic, more detailed inspection of your tricycle is important. How often this more detailed inspection is needed depends upon you.**

You, the rider/owner, have control and knowledge of how often you use your bike, how hard you use it and where you use it. Because your dealer cannot track your use, you must take responsibility for periodically bringing your bike to your dealer for inspection and service. Your dealer will help you decide what frequency of inspection and service is appropriate for how and where you use your bike. For your safety, understanding and communication with your dealer, we urge you to read this Appendix in its entirety. The materials used to make your bike determine how and how frequently to inspect.

Ignoring this WARNING can lead to frame, fork or other component failure, which can result in serious injury or death.

Understanding Metals

Steel is the traditional material for building bicycle frames. It has good characteristics, but in high performance bicycles, steel has been largely replaced by aluminum and some titanium. The main factor driving this change is interest in lighter bicycles by cycling enthusiasts.

Properties Of Metals

Please understand that there is no simple statement that can be made that characterizes the use of different metals for tricycles. What is true is

how the metal chosen is applied is much more important than the material alone. One must look at the way the bike is designed, tested, manufactured, supported along with the characteristics of the metal rather than seeking a simplistic answer.

Metals vary widely in their resistance to corrosion. Steel must be protected or rust will attack it. Aluminum and Titanium quickly develop an oxide film that protects the metal from further corrosion. Both are therefore quite resistant to corrosion. Aluminum is not perfectly corrosion resistant, and particular care must be used where it contacts other metals and galvanic corrosion can occur.

Metals are comparatively ductile. Ductile means bending, buckling and stretching before breaking. Generally speaking, of the common tricycle frame building materials steel is the most ductile, titanium less ductile, followed by aluminum.

Metals vary in density. Density is weight per unit of material. Steel weighs 7.8 grams/cm³ (grams per cubic centimeter), titanium 4.5 grams/cm³, aluminum 2.75 grams/cm³. Contrast these numbers with carbon fiber composite at 1.45 grams/cm³.

Metals are subject to fatigue. With enough cycles of use, at high enough loads, metals will eventually develop cracks that lead to failure. It is very important that you read the basics of metal fatigue below.

Let's say you hit a curb, ditch, rock, car, another cyclist or other object. At any speed above a fast walk, your body will continue to move forward, momentum carrying you over the front of the bike. You cannot and will not stay on the bike, and what happens to the frame, fork and other components is irrelevant to what happens to your body.

What should you expect from your metal frame? It depends on many complex factors, which is why we tell you that crashworthiness cannot be a design criteria. With that important note, we can tell you that if the impact is hard enough the fork or frame may be bent or buckled. On a steel bike, the steel fork may be severely bent and the frame undamaged. Aluminum is less ductile than steel, but you can expect the fork and frame to be bent or buckled. Hit harder and the top tube may be broken in tension and the down tube buckled. Hit harder and the top tube may be broken, the down tube buckled and broken, leaving the head tube and fork separated from the main triangle.

When a metal bike crashes, you will usually see some evidence of this ductility in bent, buckled or folded metal.

It is now common for the main frame to be made of metal and the fork of carbon fiber. The relative ductility of metals and the lack of ductility of carbon fiber means that in a crash scenario you can expect some bending or bucking

in the metal but none in the carbon. Below some load the carbon fork may be intact even though the frame is damaged. Above some load the carbon fork will be completely broken.

The Basics Of Metal Fatigue

Common sense tells us that nothing that is used lasts forever. The more you use something, and the harder you use it, and the worse the conditions you use it in, the shorter its life.

Fatigue is the term used to describe accumulated damage to a part caused by repeated loading. To cause fatigue damage, the load the part receives must be great enough. A crude, often-used example is bending a paper clip back and forth (repeated loading) until it breaks. This simple definition will help you understand that fatigue has nothing to do with time or age. A tricycle in a garage does not fatigue. Fatigue happens only through use.

So what kind of “damage” are we talking about? On a microscopic level, a crack forms in a highly stressed area. As the load is repeatedly applied, the crack grows. At some point the crack becomes visible to the naked eye. Eventually it becomes so large that the part is too weak to carry the load that it could carry without the crack. At that point there can be a complete and immediate failure of the part.

One can design a part that is so strong that fatigue life is nearly infinite. This requires a lot of material and a lot of weight. Any structure that must be light and strong will have a finite fatigue life. Aircraft, race cars, motorcycles all have parts with finite fatigue lives. If you wanted a tricycle with an infinite fatigue life, it would weigh far more than any tricycle sold today. So we all make a trade off: the wonderful, lightweight performance we want requires that we inspect the structure.

What To Look For

ONCE A CRACKS STARTS IT CAN GROW AND GROW FAST. Think about the crack as forming a pathway to failure. This means that any crack is potentially dangerous and will only become more dangerous.	If you find crack, replace the part.
CORROSION SPEEDS DAMAGE. Cracks grow more quickly when they are in a corrosive environment. Think about the corrosive solution as further weakening and extending the crack.	Clean your bike, lubricate your bike, protect your bike from salt, remove any salt as soon as you can.
STAINS AND DISCOLORATION CAN OCCUR NEAR A CRACK. Such staining may be a warning sign that a crack exists.	Inspect and investigate any staining to see if it is associated with a crack.
SIGNIFICANT SCRATCHES, GOUGES, DENTS OR SCORING CREATE STARTING POINTS FOR CRACKS. Think about the cut surface as a focal point for stress (in fact engineers call such areas “stress risers,” areas where the stress is increased). Perhaps you have seen glass cut? Recall how the glass was scored and then broke on the scored line.	Do not scratch, gouge or score any surface. If you do, pay frequent attention to this area or replace the part.
SOME CRACKS (particularly larger ones) MAY MAKE CREAKING NOISE AS YOU RIDE. Think about such a noise as a serious warning signal. Note that a well-maintained bicycle will be very quiet and free of creaks and squeaks.	Investigate and find the source of any noise. It may not a be a crack, but whatever is causing the noise should be fixed promptly.

Fatigue Is Not A Perfectly Predictable Science

Fatigue is not a perfectly predictable science, but here are some general factors to help you and your dealer determine how often your bicycle should be inspected. The more you fit the “shorten product life” profile, the more frequent your need to inspect. The more you fit the “lengthen product life” profile, the less frequent your need to inspect.

Factors That Shorten Product Life:

- Hard, harsh riding style
- “Hits”, crashes, jumps, other “shots” to the bike
- High mileage
- Higher body weight
- Stronger, more fit, more aggressive rider
- Corrosive environment (wet, salt air, winter road salt, accumulated sweat)
- Presence of abrasive mud, dirt, sand, soil in riding environment

Factors That Lengthen Product Life:

- Smooth, fluid riding style
- No “hits”, crashes, jumps, other “shots” to the bike
- Low mileage
- Lower body weight
- Less aggressive rider
- Non-corrosive environment (dry, salt-free air)
- Clean riding environment



WARNING: Do not ride a bicycle or component with any crack, bulge or dent, even a small one. Riding a cracked frame, fork or component could lead to complete failure, with risk of serious injury or death.

Understanding Composites

It is often necessary to remove and disassemble components in order to properly and carefully inspect them. This is a job for a professional tricycle mechanic with the special tools, skills and experience to inspect and service today's high-tech high-performance tricycles and their components.

Aftermarket “Super Light” Components

Think carefully about your rider profile as outlined above. The more you fit the “shorten product life” profile, the more you must question the use of super light components. The more you fit the “lengthen product life” profile, the more likely it is that lighter components may be suitable for you. Discuss your needs and your profile very honestly with your dealer. Take these choices seriously and understand that you are responsible for the changes.

A useful slogan to discuss with your dealer if you contemplate changing components is “Strong, Light, Cheap –pick two.”

Original Equipment Components

Tricycle and component manufacturers test the fatigue life of the components that are original equipment on your bike. This means that they have met test criteria and have reasonable fatigue life. It does not mean that the original components will last forever. They won't.

APPENDIX D: FASTENER TORQUE SPECIFICATIONS

Correct tightening torque of threaded fasteners is very important to your safety. Always tighten fasteners to the correct torque. In case of a conflict between the instructions in this manual and information provided by a component manufacturer, consult with your dealer or the manufacturer's customer service representative for clarification. Bolts that are too tight can stretch and deform. Bolts that are too loose can move and fatigue. Either mistake can lead to a sudden failure of the bolt.

Always use a correctly calibrated torque wrench to tighten critical fasteners on your bike. Carefully follow the torque wrench manufacturer's instructions on the correct way to set and use the torque wrench for accurate results.

Recommended Torque Value

COMPONENT	IN-LB	NM
Headset, Handlebar, Seat Area		
Seat fixing bolt (seat rail binder)	174–347	19.7–39.2
Handlebar fixing bolt	44–60	5.0–6.8
Crankset, Bottom Bracket, Pedal Area		
Crank bolts	305–391	34.5–44.2
Pedal (into crank)	307–350	34.7–39.5
Derailleur Shift Lever Area		
Rear derailleur cable pinch bolt	35–45	4.0–5.1
Rear derailleur mounting bolt	70–86	7.9–9.7
Shift lever	22–26	2.5–2.9
Rack Area		
Bicycle rack to frame (6mm bolts)	88.5	10
Wheel Area		
Wheel axle nuts to frame/fork	360–390	29.4–44.1
Brakes		
Brake lever to handlebar	53–69	6.0–7.8
Brake pad to caliper	50–70	5.6–7.9
Brake caliper (disc) to frame/fork	60–90	6.8–10.2
Disc rotor to hub	35–55	4.0–6.2

APPENDIX E: TRICYCLE SPECIFICATIONS

Frame	
Frame	Carbon steel
Basket	Carbon steel
Handlebar	Custom aluminum
Wheelset	
Hub	Aluminum sealed
Rim	Double wall aluminum in V shape
Spoke	Chromed 10g spokes
Tire and tube	Front: Kenda Puncture proof 20" x 2.125" Rear: Kenda Puncture proof 24" x 1.9"
Freewheel	Shimano
Drivetrain	
Motor	500W Bafang Hub DC Brushless Motor G020.500 DC Torque: 45 Nm
Cadence sensor	Magnetic 12 sensor
Derailleur	Shimano Tourney TY300
Shifter	Shimano Tourney TX50
Cassette	Shimano Tourney TZ500
Chain	KMC Chain Z8.3
Brakes	
Brake	Zoom hydraulic Disc Brake 180mm rotor and alloy lever
Electrical	
Battery	48V 13Ah Li-Ion battery
Charger	110W; 54.6V 2A
Components	
Grip	Leather type grip
Saddle	Cushioned cruiser type

Lights	Front: 85Lux Rear: Battery integrated
--------	--

Note on Tricycle Specifications

Please contact hello@integralelectrics.com if you need additional specifications. We constantly improve our product line based on customer feedback. So while we maintain up to date manuals for each model we produce, contacting us directly ensures you have the best component information available. We can work directly with you or your local bicycle technician to support all components of your tricycle.

APPENDIX F: DISPLAY ERROR CODES

Error	Declaration	Troubleshooting
04	The throttle has fault.	1. Check the connector of throttle whether they are correctly connected. 2. Disconnect the throttle, If the problem still occurs, please contact your retailer. (only with this function)
05	The throttle is not back in its correct position.	Check the throttle can adjust back into its correct position, if the situation does not improve, please change to a new throttle.(only with this function)
07	Overvoltage protection	1. Remove the battery. 2. Re-Insert the battery. 3. If the problem persists, please contact your retailer.
08	Error with the hall sensor signal inside the motor	Please contact your retailer.
09	Error with the Engine phase's	Please contact your retailer.
10	The temperature inside the engine has reached its maximum protection value	1. Turn off the system and allow the Pedelec to cool down. 2. If the problem persists, please contact your retailer.
11	The temperature sensor inside the motor has an error	Please contact your retailer.
12	Error with the current sensor in the controller	Please contact your retailer.

Error	Declaration	Troubleshooting
13	Error with the temperature sensor inside of the battery	Please contact your retailer.
14	The protection temperature inside the controller has reached its maximum protection value	1. Turn off the system and let the pedelec cool down. 2. If the problem persists, please contact your retailer.
15	Error with the temperature sensor inside the controller	Please contact your retailer.
21	Speed sensor Error	1. Restart the system 2. Check that the magnet attached to the spoke is aligned with the speed sensor and that the distance is between 10 mm and 20mm. 3. Check that the speed sensor connector is connected correctly. 4. If the error persists, please contact your retailer.
25	Torque signal Error	1. Check that all connections are connected correctly. 2. If the error persists, please contact your retailer.
26	Speed signal of the torque sensor has an error	1. Check the connector from the speed sensor to make sure it is connected correctly. 2. Check the speed sensor for signs of damage. 3. If the problem persists, please contact your retailer.
27	Overcurrent from controller	Please contact your retailer.
30	Communication problem	1. Check all connections are correctly connected. 2. If the error persists, please contact your retailer.
33	Brake signal has an error (If brake sensors are fitted)	1. Check all connectors. 2. If the error continues to occur, please contact your retailer.

Error	Declaration	Troubleshooting
35	Detection circuit for 15V has an error	Please contact your retailer.
36	Detection circuit on the keypad has an error	Please contact your retailer.
37	WDT circuit is faulty	Please contact your retailer.
41	Total voltage from the battery is too high	Please contact your retailer.
42	Total voltage from the battery is too low	Please contact your retailer.
43	Total power from the battery cells is too high	Please contact your retailer.
44	Voltage of the single cell is too high	Please contact your retailer.
45	Temperature from the battery is too high	Please contact your retailer.
46	The temperature of the battery is too low	Please contact your retailer.
47	SOC of the battery is too high	Please contact your retailer.
48	SOC of the battery is too low	Please contact your retailer.
61	Switching detection defect	Please contact your retailer. (only with this function)
62	Electronic derailleur cannot release.	Please contact your retailer. (only with this function)
71	Electronic lock is jammed	Please contact your retailer. (only with this function)
81	Bluetooth module has an error	Please contact your retailer. (only with this function)

