

STANCHION CART ASSEMBLY INSTRUCTIONS

STEP INSTRUCTION

- A** Install swivel casters (#2) to cart base (#1) using four **M8x16mm bolts** and four **M8 locknuts** as shown in **Figure A**. Repeat step for other swivel caster.
- B** Install fixed casters (#3) to cart base (#1) using four **M8x16mm bolts** and four **M8 locknuts** as shown in **Figure B**. Repeat step for other fixed caster.
- C** Install cart post (#4) to cart base (#1) using one **M8x45mm bolt** and one **M8 washer** as shown in **Figure C**. Repeat step for other cart post.
- D** Install vertical upright (#5) to cart base (#1) using two **M8x60mm bolts**, two **M8 washers** and two **M8 locknuts** as shown in **Figure D**. Repeat step for other vertical upright.
- E** Install handle/grid (#6) to vertical uprights (#5) using four **M8x20mm bolts**, four **M8 washers** and four **M8 locknuts** as shown in **Figure E**.

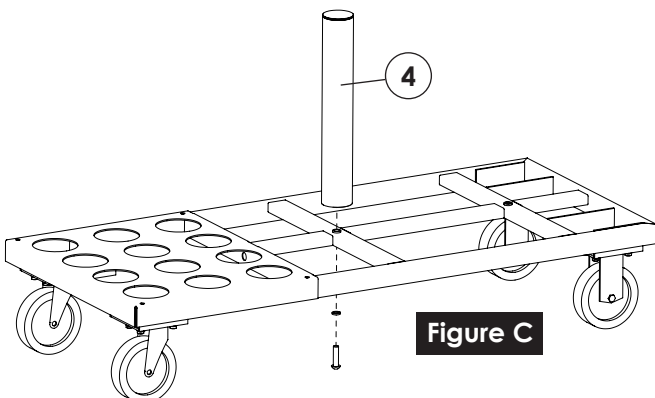
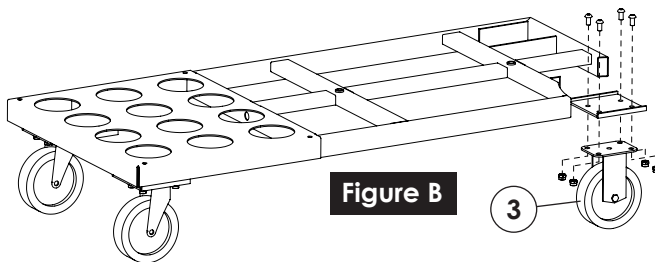
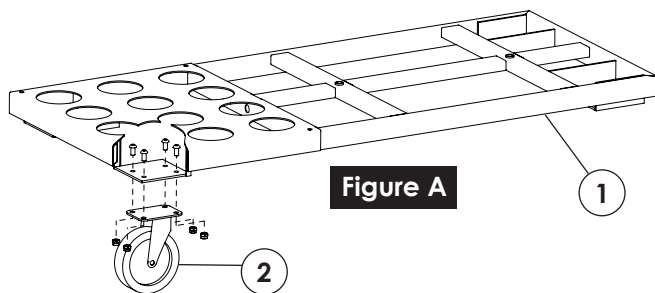

Stanchion Cart Parts List

Item#	Description	Qty
1	Cart Base	1
2	Swivel Caster	2
3	Fixed Caster	2
4	Cart Post	2
5	Vertical Upright	2
6	Handle/Grid	1

Hardware List

Description	Qty
M8 x 16mm Bolt	16
M8 x 20mm Bolt	4
M8 x 60mm Bolt	4
M8 x 45mm Bolt	2
M8 Locknut	24
M8 Washer	10

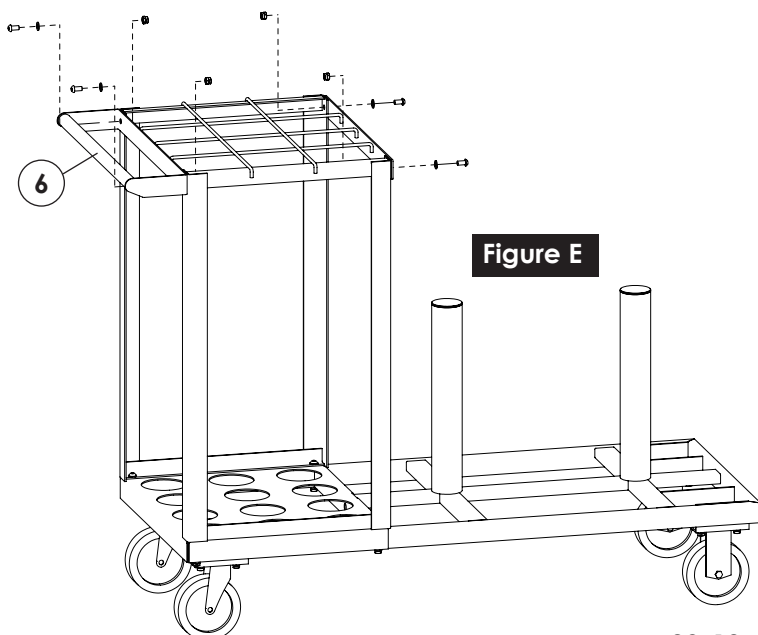
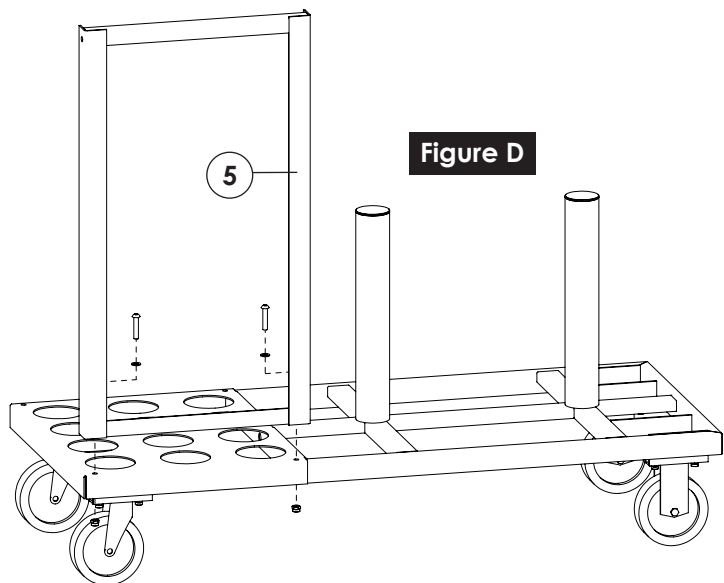

03-18

USWEIGHT

US Weight
4594 E. Radio Tower Lane
Olney, IL 62450

PH # 1-877-201-9748
usw.sales@escaladesports.com
Additional product information
can be found at
www.usweight.com