

# USWEIGHT

Thank you for your business. We value our customers.

US Weight  
4594 E. Radio Tower Lane  
Olney, IL 62450

PH # 1-877-201-9748  
usw.sales@escaladesports.com

Additional product information and installation videos can be found at [www.usweight.com](http://www.usweight.com)

## DO NOT RETURN

Contact manufacturer for any product issues.

[usw.sales@escaladesports.com](mailto:usw.sales@escaladesports.com) - toll free at [1-877-201-9748](tel:1-877-201-9748).

# QuikSecure Sentry

## Parts List:

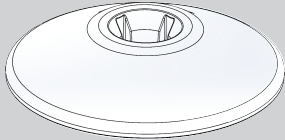

Base (2)



Post (2)



No Tools Required

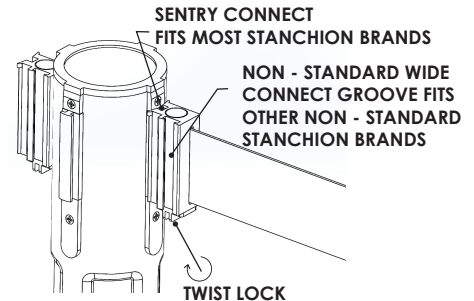
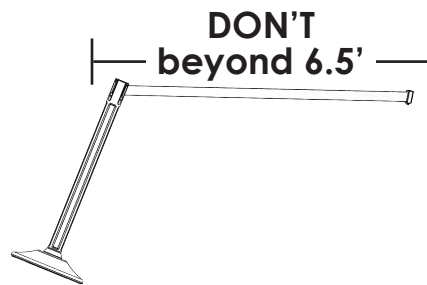
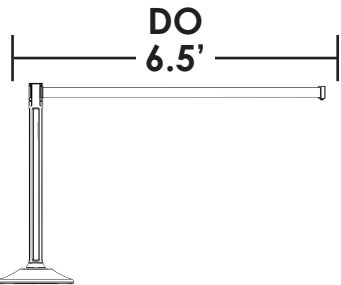

### IMPORTANT NOTE: - QuikSecure Sentry 6.5 foot retractable belt stanchion.

- The QuikSecure Sentry is advertised and sold as a 6.5' retractable belt stanchion. We do not advise using the belt beyond the intended 6.5' length, as the QuikSecure Sentry may want to tip.
- Cassette Braking Mechanism - your belt cassette is equipped with a braking mechanism. The purpose of the mechanism is to safely slow belt retraction.

## Assembly Instructions

1. Insert the post into the base by aligning the pin at the bottom of the post to the cross cutout in the base.

Once aligned, push post down completely and rotate post  $\frac{1}{8}$  of a turn to lock post/pin into place. See Figure A.

2. Once post is assembled to base, stanchion can be positioned for use.

3. To remove post, push post down completely and rotate post  $\frac{1}{8}$  of a turn. Lift post from base.



↓ Push Post Down Completely

Important!

↻ Rotate  $\frac{1}{8}$  Turn

- A Bottom View of Base pin shown locked in place.

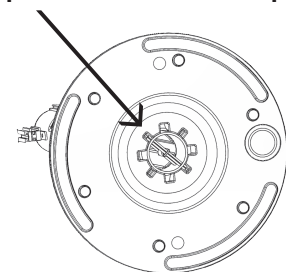

**WRONG!**

