USER MANUAL

MODEL:

SS3

WALK THROUGH FOOTWEAR SANITIZER

English (Original Instructions)



USER MANUAL: SS3

READ ALL INSTRUCTIONS BEFORE OPERATING EQUIPMENT

Table of Contents

System Requirements	03	Maintenance	10
Installation	05	Troubleshooting	11
Operation	08	Appendices	
Cleaning	09	Parts Callouts	14



WARNING:

1. All personnel using this unit must be familiar with the information contained in this manual. Follow all installation and maintenance instructions.
2. Ensure solid footing and use both hands when operating the unit.
3. Avoid contact of chemicals with skin and eyes. If contact occurs, see MSDS sheet for further first aid measures.
4. Follow safety instructions of chemical manufacturer (MSDS).
5. Always follow plant and OSHA guidelines about the use of equipment.
6. Disconnect air before servicing equipment.
7. Always follow safety precautions and obey warning labels. Failure to do so could result in injury or death.

USER MANUAL: SS3

READ ALL INSTRUCTIONS BEFORE OPERATING EQUIPMENT

Overview

The SS3 footwear sanitizer is a compact, low cost way to quickly and efficiently apply sanitizer to the bottom of footwear in an easy to use, walk through model. Designed for dry facility environments, the SS3 increases pathogen prevention while maintaining minimal moisture output.

Using only compressed air the SS3 applies 0.2 ounces of sanitizer to the bottom of each boot, simultaneously, via 8 misting nozzles (4 per boot). The misting output reduces over-spray while still providing adequate solution coverage to the entire sole, preventing cross contamination between high risk environments and control zones.

Specifications

- Construction: 304 Stainless Steel, HDPE Polypropylene, PVC, Viton (seals)
- Weight: 93 lbs. (42.18 kg.)
- Dimensions: 29.5" x 28" x 42"
749.3 x 711.2 x 1,066.8 mm
- Solution consumption: 0.4/oz. per activation*
- Noise Level: Less than 70 dB(A)

**Dilution rates and flow rates given are based on chemical with viscosity of water and factory air pressure settings.*

Requirements

- Compressed Air: 70-80 PSI*
Air regulator with 1/4" industrial quick connect supplied with unit
- Liquid Temperature Range: 40-100°F (4-37°C)
- Chemical compatibility: Chemical products used with this equipment must be formulated for this type of application and compatible with unit materials and plumbing seals.

NOTE: For more information on chemical compatibility consult the chemical manufacturer, SDS for your product, or contact our support department.

USER MANUAL: SS3

READ ALL INSTRUCTIONS BEFORE OPERATING EQUIPMENT

Installation Requirements

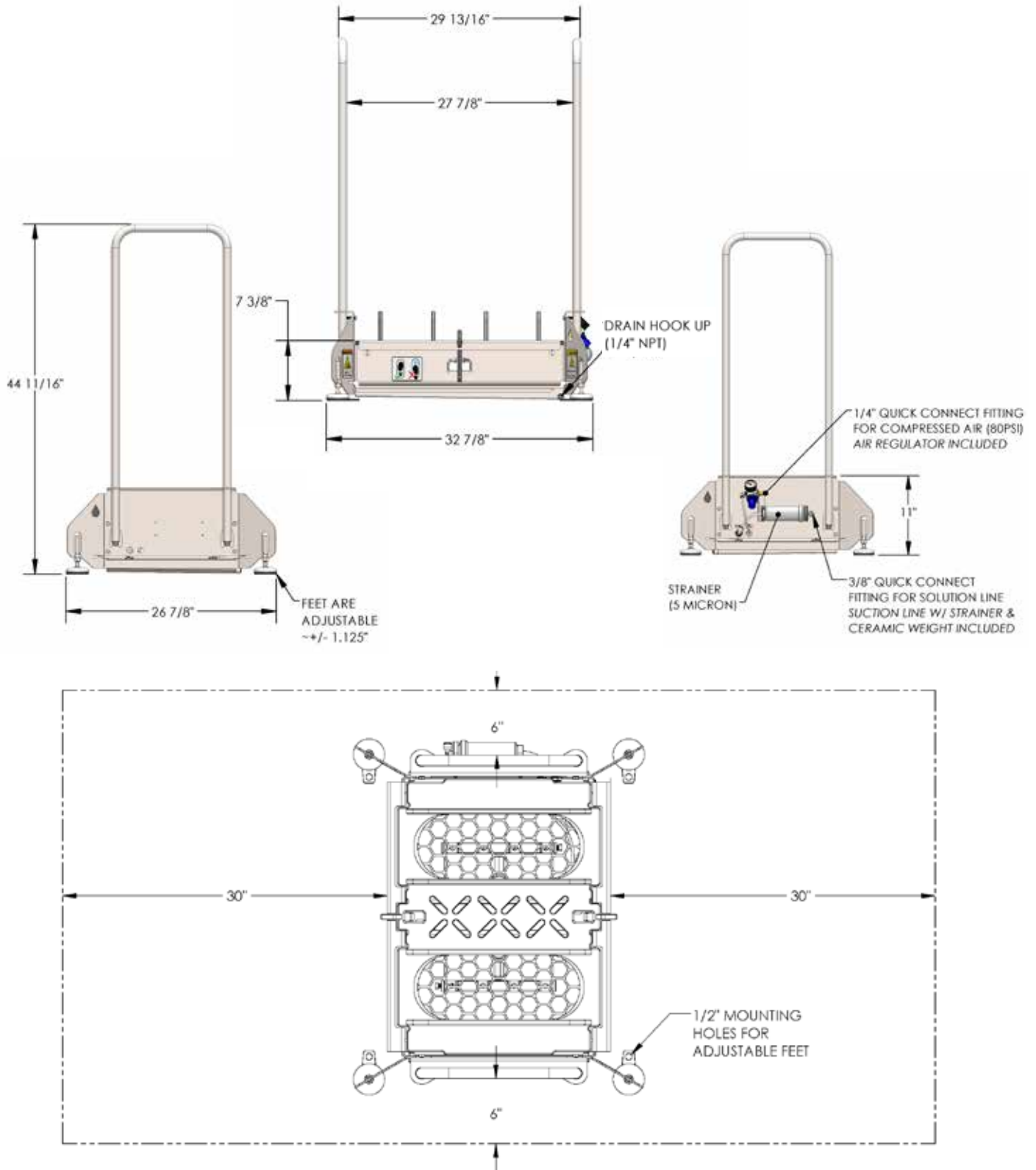

USER MANUAL: SS3

READ ALL INSTRUCTIONS BEFORE OPERATING EQUIPMENT

Installation

Installing Handrail

Due to the shipment size, the SS3 will arrive with the handrails disconnected.

1. Place handrails through the mounting holes on each side of the unit [Figure 5.1].
2. Using a 1/2" wrench or socket, secure the handrails in place using the included 5/8" bolts, with lock washers, to the bottom bracket of the each handrail [Figure 5.2].
3. Using two 1/2" wrenches tighten the bolt through the locknut until the bolt bottoms out against the handrail to secure in place [Figure 5.2].
4. Repeat for opposing handrail (8 bolts total).

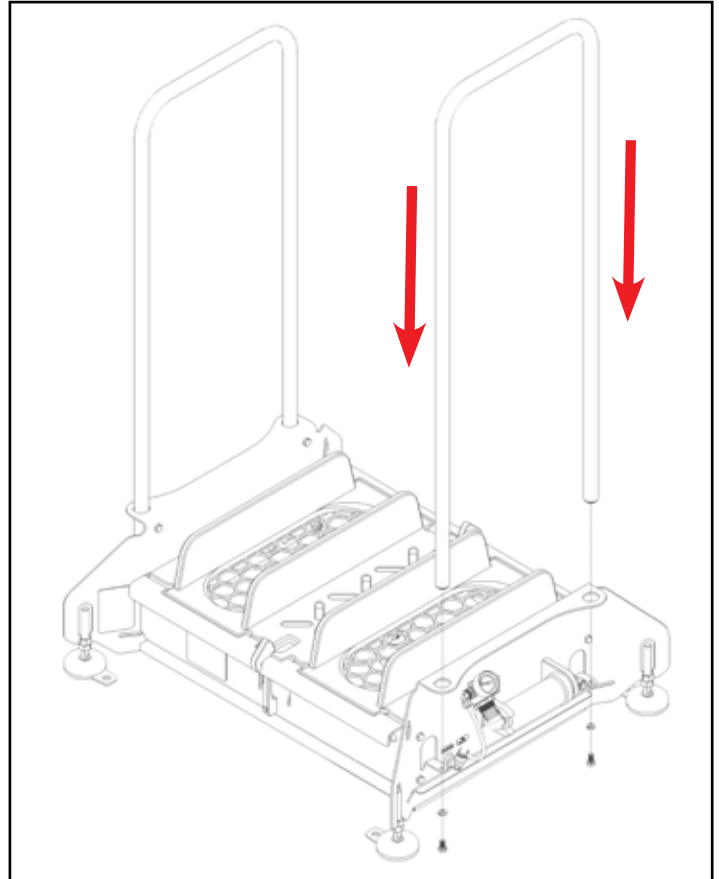

Fig. 5.1: Installing Handrail

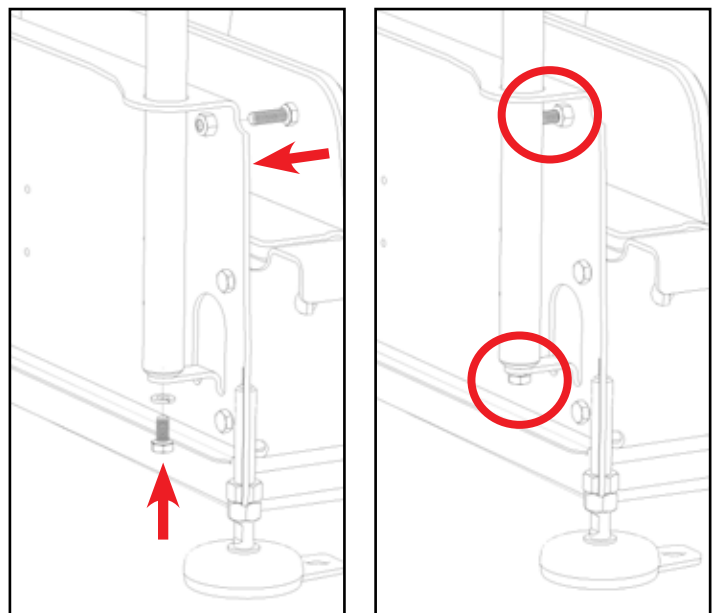

Fig. 5.2: Handrail stabilization bolts

USER MANUAL: SS3

READ ALL INSTRUCTIONS BEFORE OPERATING EQUIPMENT

Installation (continued)

Installing and Mounting the Unit

1. Set unit in desired location.
2. Aspects to consider when deciding on placement:
 - Clearance for entering and exiting.
 - Traffic flow for unit operation.
 - Emergency exit paths or egress in case of emergency.
 - Head room for personnel while using the unit.
 - Flat and/or level floor surface
3. Using a level and 3/4" wrench, stabilize the unit and level in all directions by adjusting the feet and lock nuts as necessary [Figure 6.1].
4. Using the 4 mounting brackets located at each corner, securely fasten the unit to the floor with appropriate hardware for the given material (i.e. concrete anchors, bolts, etc.) [Figure 6.2].

WARNING

If not properly secured to floor the unit may tip over and has the potential to cause personal injury.

5. Using 1/4" industrial quick-disconnect, connect compressed air supply to the air regulator on the side of the unit (80 PSI recommended) [Figure 6.3].
6. Using the included suction line or similar 3/8" OD tubing, connect solution to the unit via the 3/8" quick connect fitting on the inlet port of the filter.

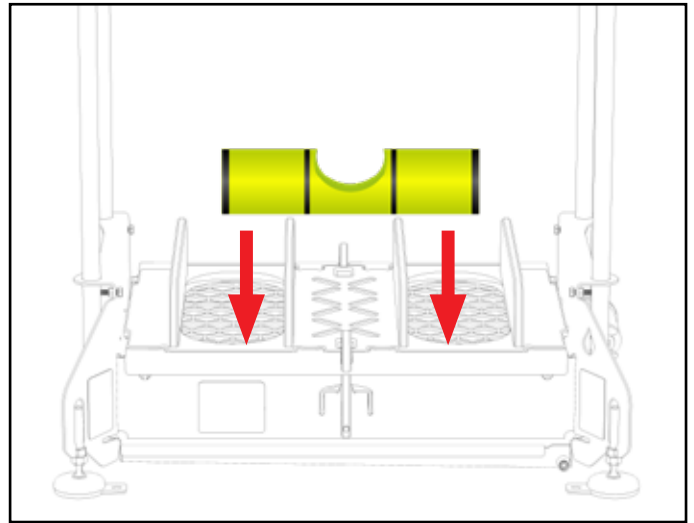

Fig. 6.1: Verify level of unit at each end

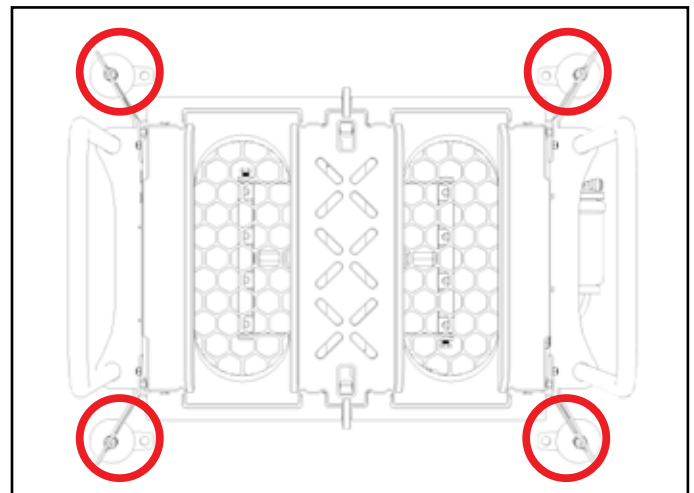

Fig. 6.2: Mounting bracket locations

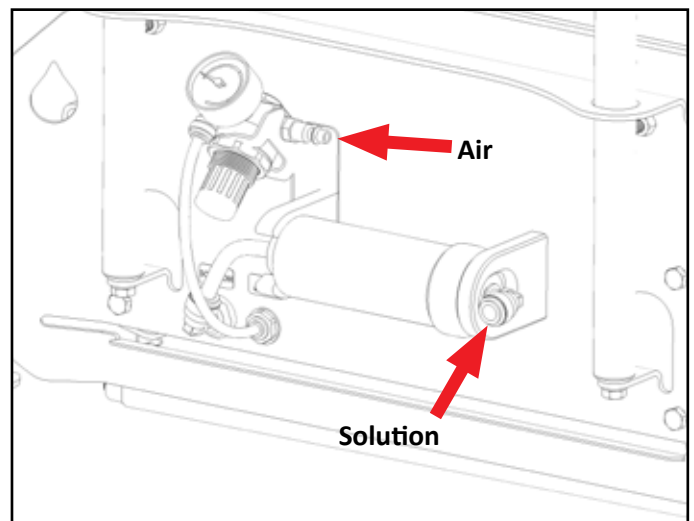

Fig. 6.3: Solution and air line quick fit connections

USER MANUAL: SS3

READ ALL INSTRUCTIONS BEFORE OPERATING EQUIPMENT

Installation (continued)

Installing & Removing Base Plate

1. To remove the base plate, pull back on the plastic latch to free the plate [Figure 7.1].
2. The base plate can be hinged open if desired as shown in [Figure 7.2].
3. Base plate can be removed entirely for COP processes or sprayed down in position.
4. To re-inset, orient as shown [Figure 7.1] and slide past plastic latches until locked into position.

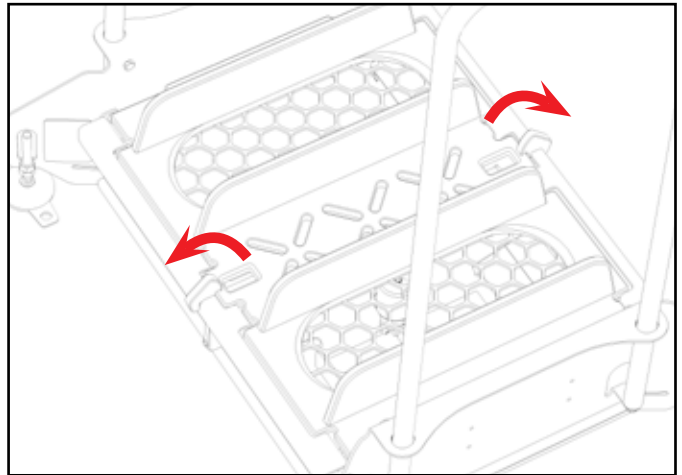

Fig. 7.1: Releasing foot plate latches

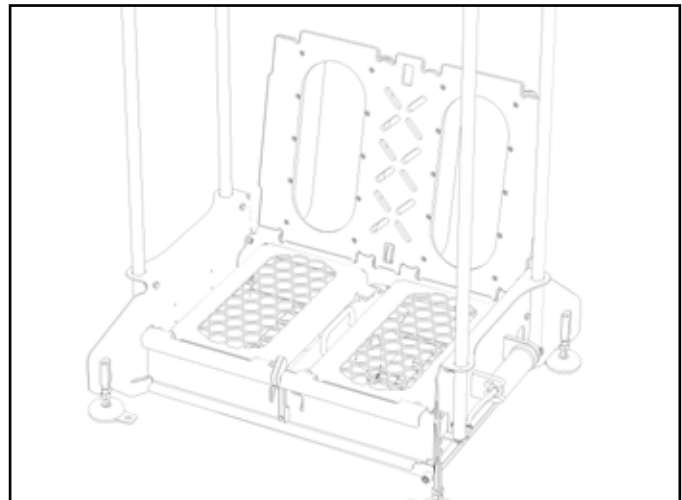

Fig. 7.2: Hinged open foot plate

Removing Plumbing Assembly

1. Hinge open or remove the base plate as previously described.
2. Hinge open each mesh plate.
3. Disconnect the air and solution lines from their quick connect bulk-head fittings.

WARNING

Shut off air supply and exhaust air and solution lines prior to disconnecting.

4. Pull up on the handle to remove the entire plumbing assembly [Figure 7.3].

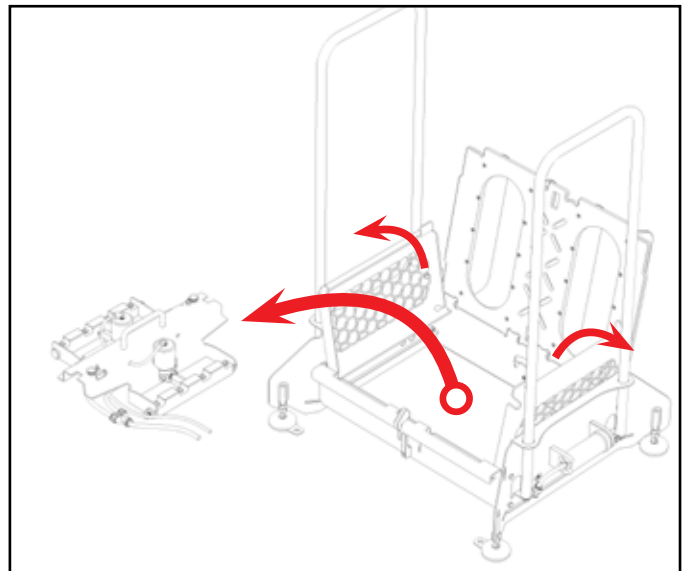

Fig. 7.3: Removing Plumbing Assembly

USER MANUAL: SS3

READ ALL INSTRUCTIONS BEFORE OPERATING EQUIPMENT

Operation

Priming

When first connected (either from initial set-up, after maintenance, or replacement of solution) the unit must be primed for proper activation to occur. Ensure handrails and base plate are secured and the system itself properly installed.

WARNING

This unit is for use with fully protective footwear only. Do not activate the unit if a user's feet are not positioned above nozzle system.

1. Enter the unit from either opening.
2. Step up onto the unit while gripping the handrails.
3. Position feet within base plate outlines, centering each foot above its nozzle system [Figure 8.1].

NOTE: Unit will not operate with only one foot in place. Both feet must be on the unit, in position, for sanitizer activation.

4. Step down, with both feet - the unit will activate as compressed air is engaged and the suction line will begin to draw solution.
5. Repeatedly lift one, or both feet, to cycle the unit multiple times until primed.
6. Once primed, the unit will mist solution evenly between both nozzle manifold assemblies and is ready for normal use.

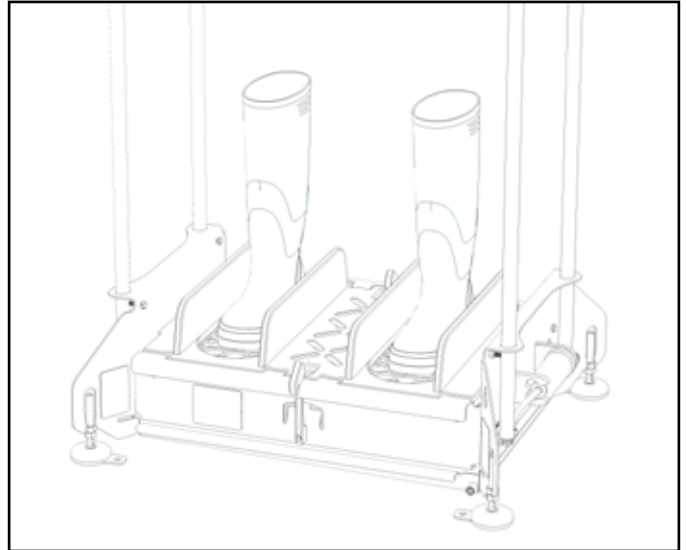
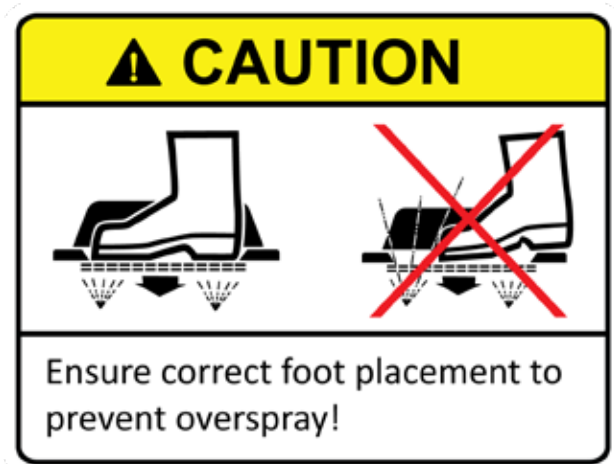

Fig. 8.1: Foot/Boot position for unit operation



USER MANUAL: SS3

READ ALL INSTRUCTIONS BEFORE OPERATING EQUIPMENT

Operation (continued)

General Use

Before operating the unit, ensure solid footing and use both hands on the handrails for support.

1. Enter the unit from either opening.
2. Step up onto the unit while gripping the handrails.
3. Position feet within base plate outlines, centering each foot above its nozzle system [Figure 9.1].
4. When both feet have stepped onto the base, the unit will activate.

NOTE: Unit will not operate with only one foot in place. Both feet must be on the unit, in position, for sanitizer activation.

5. Step down to exit the unit.
6. System is immediately recharged upon exit and is ready for the next user.

Cleaning and Wash-Down

1. Slide out catch pan from either opening to remove [Figure 9.2].
2. Empty/dispose of accumulated solution and/or debris as necessary.
3. Remove the base plate and plumbing assembly from the unit (if desired).
4. Base plate can be washed individually, in a COP tank, or wash machine.
5. The frame can be washed down by conventional means.

NOTE: Consult materials of construction (page 2) for appropriate cleaning solution compatibility.

6. Replace plumbing assembly, catch pan, and base plate before resuming normal operation.

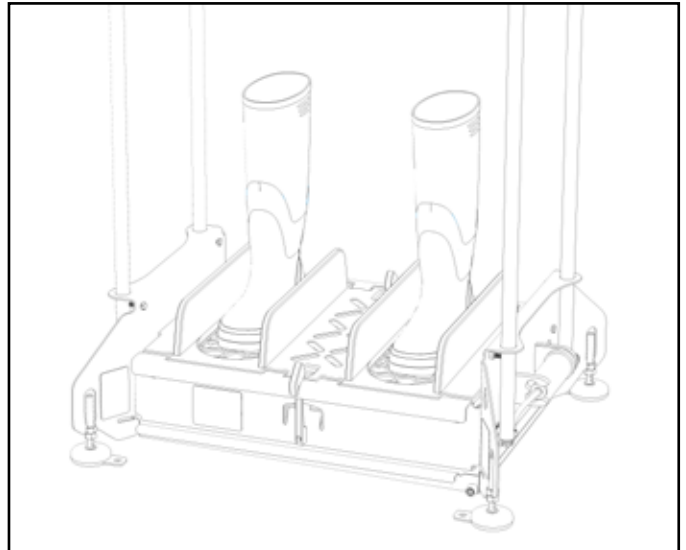

Fig. 9.1: Foot/Boot position for unit operation

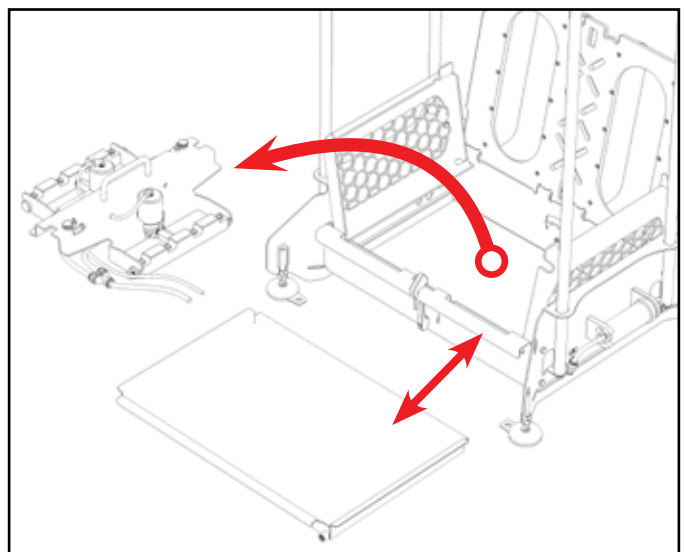
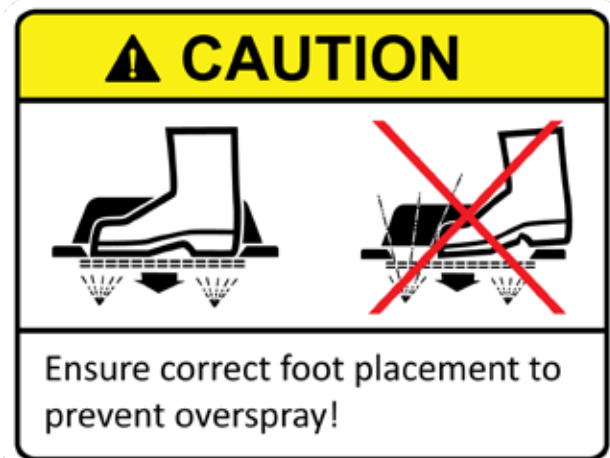

Fig. 9.2: Removing debris and plumbing assembly

USER MANUAL: SS3

READ ALL INSTRUCTIONS BEFORE OPERATING EQUIPMENT

Maintenance

The following maintenance procedures are recommended for normal use. Units which see a high amount of daily use should be inspected more frequently as necessary.



WARNING

Shut off air supply and exhaust air and solution lines prior to maintenance procedures. Always wear appropriate personal protective equipment (PPE) when operating or servicing unit.

Daily:

- Check catch pan for solution or debris accumulation and empty as necessary.
- Inspect plastic base plate and stainless steel mesh plates for soil or solution accumulation and clean as necessary.
- Check solution level to ensure unit remains primed.

Weekly:

- Inspect solution and air lines for leaks.
- Verify nozzles assembly is free of debris and/or clogs. Rinse with low pressure water to clean.
- Check solution line for debris build-up on strainer/filter (if used). Clean or replace as necessary.
- Ensure solid handrails and mounting to floor.
- Check air pressure is set to 80 PSI.

Monthly:

- Check all fasteners to ensure they are tight.
- Check misting nozzles for clogs or irregularities.
- Ensure warning labels and decals are present and in good condition.

Quarterly:

- Inspect structure for cracked welds or bent/damaged components.
- Check plumbing assembly for tight connections.
- Inspect plumbing fittings for cracked or damaged connections.
- Inspect filter and replace if over 6 months old or if misting quality/amount has declined.

Recommended Spare Parts:

Part No.	Description
M1462	SINGLE SHOT-AIR OPERATED OUTPUT-1/4IN PORTS
P2077	CHECK VALVE 1/4" MNPT x 2-7/8", PVC, Viton Seals
P2086	VALVE STEM, BRASS BODY WITH SS STEM
P2089	CHECK VALVE 1/4 MNPT X 1/4 BARB, VITON, PVC
P2110	FILTER INLINE SEDIMENT 2X6X.375 QUICK FIT PP
P2327	NOZZLE, MISTING, FULL CONE, 1/8" MNPT, 3 GPH AT 40 PSI, 303SS

USER MANUAL: SS3

READ ALL INSTRUCTIONS BEFORE OPERATING EQUIPMENT

Troubleshooting



WARNING

Shut off air supply and exhaust air and solution lines prior to maintenance procedures. Always wear appropriate personal protective equipment (PPE) when operating or servicing unit.

Unit is not misting solution:

- Ensure solution container is full, connected to the unit, and primed (see instructions on page 8).
- Check facility compressed air supply and regulator settings (see system requirements on page 3).
- Verify plumbing assembly (inside base) is in position and connected to the interior bulk heads.
- Check plumbing components for damage or points of failure (i.e. valve stem, spring plunger, etc.)
- Ensure user is positioning feet on both mesh plates, at the same time (see operation instructions on page 9).

Unit is spraying irregularly:

- Ensure solution container is full and connected to the unit.
- Check filter, strainer on suction line, and/or spray nozzles for debris build-up - remove, clean, and replace as necessary.
- Verify facility compressed air supply and regulator settings (see system requirements on page 3).
- Ensure connection lines from plumbing assembly inside the unit are not kinked or pinched.

Spray nozzle is not misting:

- Check nozzle for debris build-up or clogs - remove, clean, and replace as necessary.
- Ensure nozzle is secure and fully attached to the spray manifold.
- If necessary repair or replace the nozzle (see page 14 for manufacture part number).

Unit is not staying primed:

- Ensure solution container is full and connected to the unit.
- Verify air and solution lines are connected.
- Check air and solution lines for leaks or failing connection points.
- Remove plumbing assembly and check all connection points and fittings (replace and reconnect to bulk heads when complete).



More Information?

Please contact your equipment representative or manufacturer for further support.

USER MANUAL: SS3

READ ALL INSTRUCTIONS BEFORE OPERATING EQUIPMENT

Appendix A - Parts Callout: Main Assembly

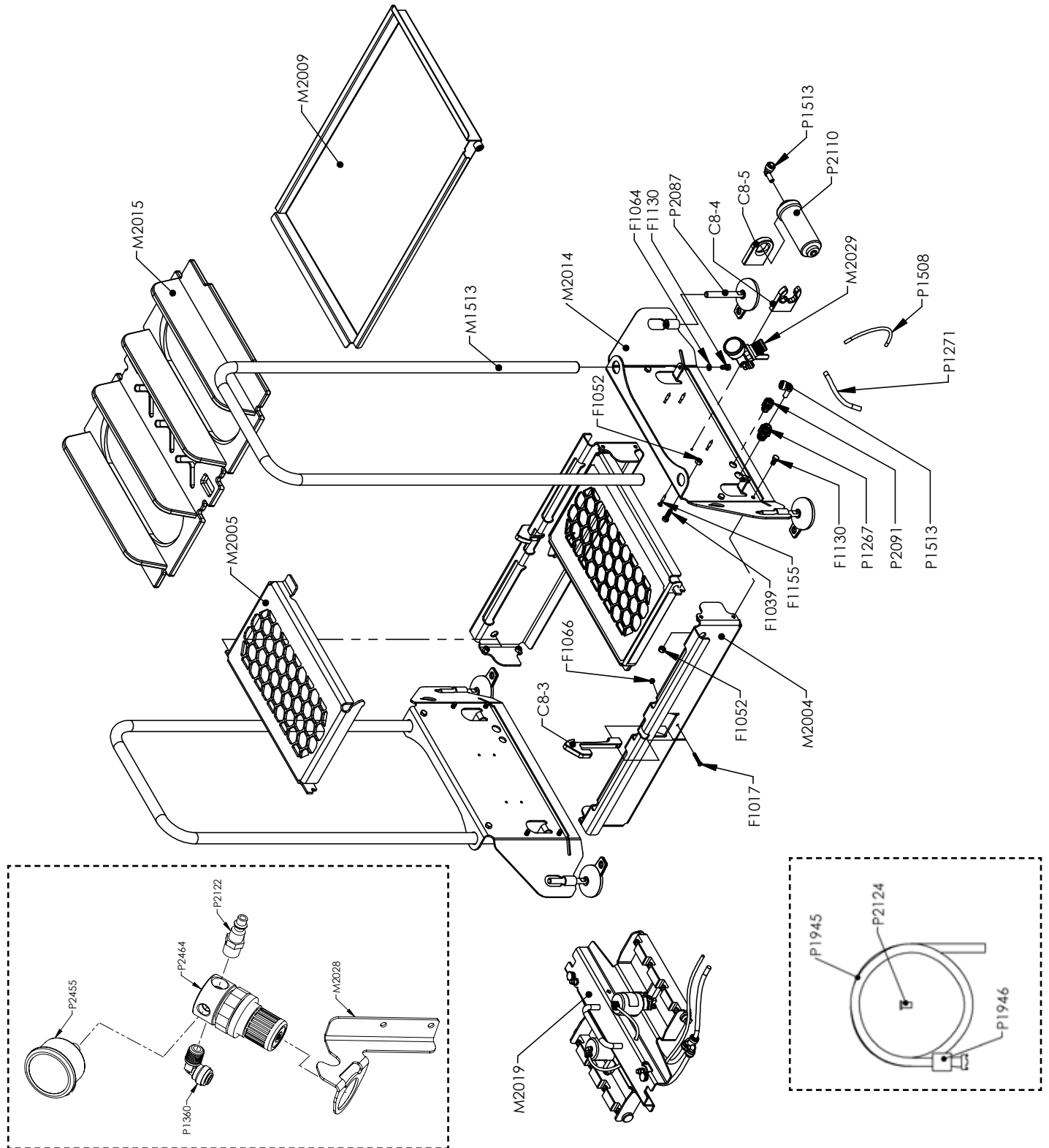

USER MANUAL: SS3

READ ALL INSTRUCTIONS BEFORE OPERATING EQUIPMENT

Appendix A - Parts Callout: Plumbing Assembly

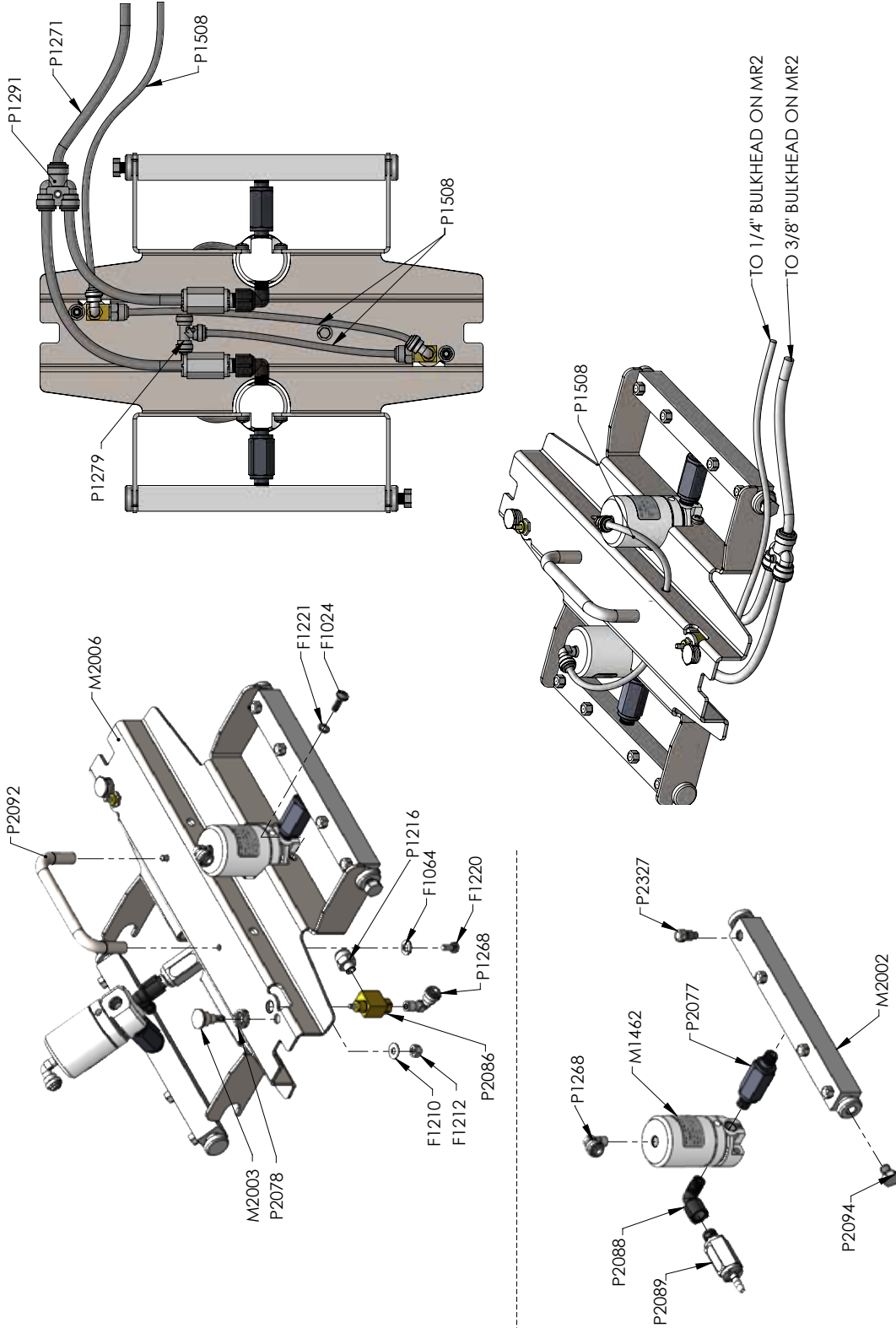

USER MANUAL: SS3

READ ALL INSTRUCTIONS BEFORE OPERATING EQUIPMENT

Appendix A - Parts Callout

Part No.	Description
C8-3	BLX-MR2 LATCH, HDPE
C8-4	FILTER CLIP 1.25 INCH
C8-5	FILTER CLIP CLOSED
F1017	BOLT HHC 10-32 x 1 1/4 SS
F1024	SCREW MACHINE 1/4-20 x 3/4 SS PHILLIPS
F1039	BOLT HHC 5/16-18 x 1 SS
F1052	NUT NYLOCK 5/16-18 SS
F1064	WASHER SPLIT LOCK 5/16 SS
F1066	NUT NYLOCK 10-32 SS
F1128	WASHER SPLIT LOCK 1/4 SS
F1130	BOLT HHC 5/16-18 X 5/8" SS
F1155	SCREW SHARX 10 X 1-1/4 PAN HD 316SS
F1202	NUT HEX 1/2-13 316SS
F1210	WASHER 1/4 316SS
F1212	NUT NYLOCK 1/4-20 316SS
F1220	BOLT HHC M6 X 12 316SS
F1221	WASHER SPLIT LOCK 1/4 316SS
M1462	PUMP-SINGLE SHOT-AIR OPERATED-0.2 OZ PER SHOT-1/4IN PORTS
M1637	HANDLE WELDMENT MBS-100 SINGLE
M2002	MANIFOLD, 1/8" 4-PORT, 10 x 1, 1/4" NPT, PP
M2003	BLX-MR2 SPRING PLUNGER
M2004	BLX-MR2 FRONT PLATE
M2005	BLX-MR2 GRATE PLATE
M2006	BLX-MR2 PUMP BRIDGE
M2009	BLX-MR2 CATCH PAN WELDMENT
M2014	BLX-MR2 SIDE PLATE WELDMENT
M2015	BLX-MR2 BASE LOCATOR PLATE ASSEMBLY
M2017	LABEL BLX-MR2 STEP INFOGRAPH
M2018	LABEL WARNING CHEMICAL SPRAY HAZARD
M2019	BLX-MR2 PLUMBING KIT
M2028	BLX-MR2 REGULATOR BRACKET
M2029	BLX-MR2 AIR REGULATOR ASSEMBLY
P1216	QUICK FIT ADAPTER 1/8" NPT X 1/4" TUBE

Part No.	Description
P1248	LABEL SLIP HAZARD
P1252	PIPE PLUG 1/4" NPT SOCKET HD SS
P1267	QUICK FIT BULKHEAD 3/8"
P1268	QUICK FIT ELBOW 1/8" NPT X 1/4" TUBE
P1271	3/8" OD POLYETHYLENE TUBING - NATURAL
P1271	3/8" OD POLYETHYLENE TUBING - NATURAL
P1279	QUICK FIT TEE 1/4"
P1291	QUICK FIT WYE 3/8"
P1360	QUICK FIT ELBOW 1/4" NPT X 1/4" TUBE
P1508	1/4" OD POLYETHYLENE TUBING - NATURAL
P1508	1/4" OD POLYETHYLENE TUBING - NATURAL
P1513	QUICK FIT STEM ELBOW 3/8" X 3/8"
P1945	VENTURI INJECTOR 1/4" SUCTION LINE AND STRAINER
P1946	VENTURI INJECTOR SUCTION WEIGHT CERAMIC FOR 1/4" TUBE
P2077	CHECK VALVE 1/4" MNPT x 2-7/8", PVC, Viton Seals
P2078	SPRING, 302 SS, 0.72" OD, 0.063" WIRE SIZE
P2086	VALVE STEM, BRASS BODY AND SS STEM
P2087	LEVELING FOOT .5-13 X 4 ANCHORING SS
P2088	PIPE ELBOW STREET .25 PP
P2089	CHECK VALVE 1/4 BARB X 1/4 MNPT, VITON, PVC
P2091	QUICK FIT BULKHEAD 1/4"
P2092	HANDLE U, SS, TAPPED M6 HOLES
P2094	PIPE PLUG 1/8 PP
P2110	FILTER INLINE SEDIMENT 2X6X.375 QUICK FIT PP
P2122	QUICK FIT ADAPTER AIR INDUSTRIAL X 1/4" NPT BRASS
P2124	TUBE FITTING 1/4" ID POLYPROPYLENE
P2327	NOZZLE, MISTING, FULL CONE, 1/8" MNPT, 3.0 GPH AT 40 PSI, 303SS
P2455	GAUGE, PRESSURE, 1-1/2", 0-150psi, 1/8" NPT
P2464	REGULATOR, AIR, 1/4" NPT, COMPACT
P2464	REGULATOR, AIR, 1/4" NPT, COMPACT