

5 Gallon Foam Unit

Operation Manual

FI-5N

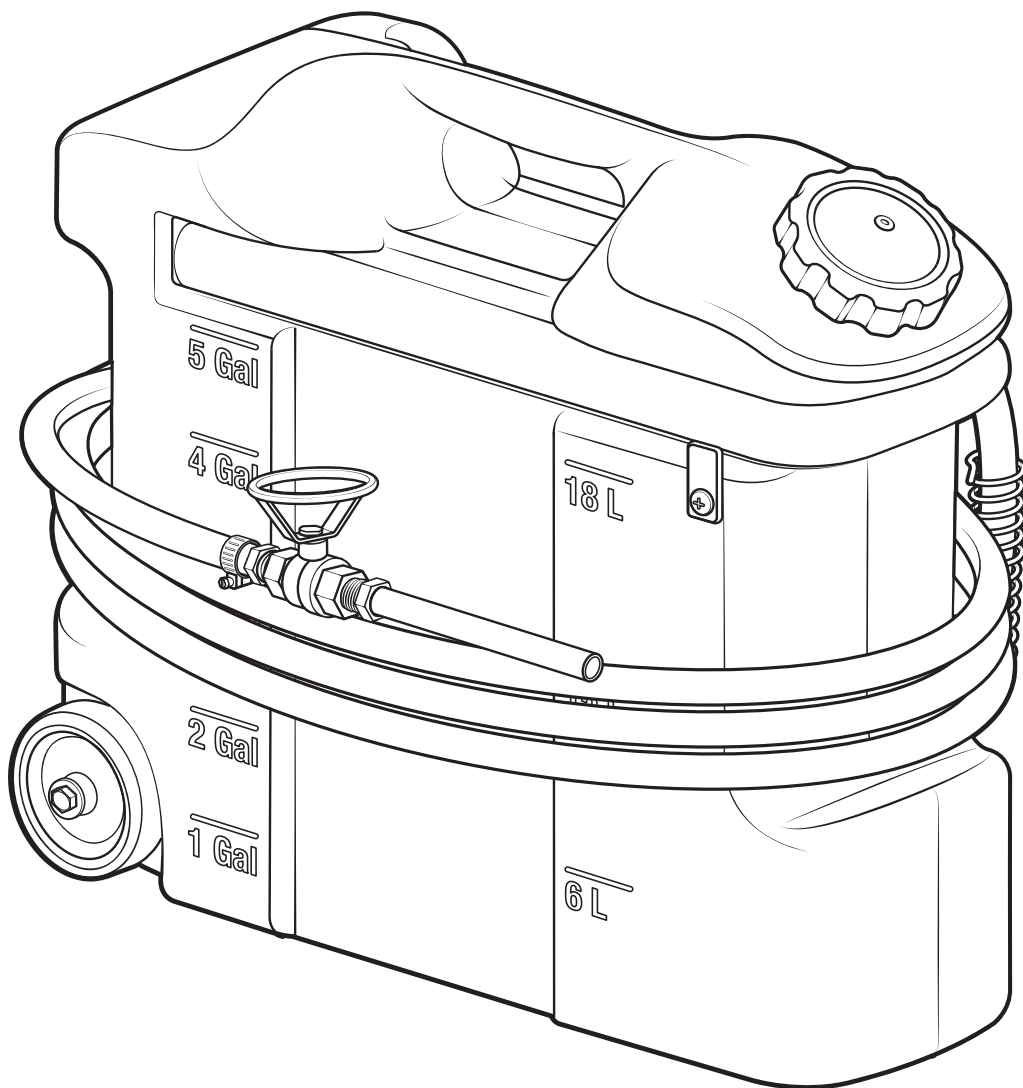

READ ALL INSTRUCTIONS BEFORE USING OR
SERVICING THIS UNIT. KEEP THIS MANUAL IN A
LOCATION THAT IS READILY AVAILABLE TO USERS
AND SERVICE TECHNICIANS.

English (Original Instructions)



Scan this code for
operation manual

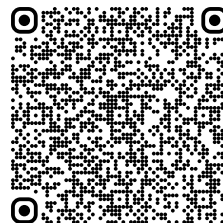

Safety

WARNING

PEOPLE OR OBJECTS CAN BE HURT OR DAMAGED IF THIS UNIT IS NOT USED CORRECTLY!



Failure to read all the instructions before operating the unit may result in personal injury or death from the improper use or the chemical solution. Anyone handling, operating or using the unit must read and understand the instructions in the manual. The buyer assumes all responsibility for safety and proper use in accordance with the instructions.



Using or servicing the unit without appropriate personal protective equipment (PPE) may result in serious injury such as burns, rashes, eye, throat or lung damage and death. Always wear PPE as indicated in the Safety Data Sheet (SDS) when using or servicing the unit. Protect eyes, skin, and lungs against drifting spray.



Chemical solutions may pose a health risk and death if they contact the skin or eyes, are inhaled or swallowed. Always read and follow all chemical safety precautions and handling instructions provided by the chemical manufacturer and the SDS associated with the chemical solution before using the unit.



Pressure within the equipment may cause an unexpected release of the chemical solution and cause serious injury such as burns, rashes, eye damage, throat or lung damage and death. Always depressurize and clean the unit after each use. Release any remaining air pressure by opening the discharge ball valve. Never leave the unit unattended while pressurized.

Using the unit with fluid temperatures above 100°F (37.8°C) may result in scalding, burns, serious injury or death. DO NOT use a solution with a temperature above 100°F (37.8°C).

Operating the unit when damaged or leaking may result in exposure to chemical solutions, serious injury or death. Never use the unit if it is damaged or leaking.

Never point the discharge wand at yourself, another person, or any object you do not want covered in chemical.



Using incoming air pressure exceeding 100 psi (6.9 bar) may result in pressure buildup, explosion, serious injury or death. DO NOT exceed 100 psi (6.9 bar) incoming air pressure when operating the unit.

Use of hydrocarbons and flammable products may result in explosions, fire and serious injury or death. Never use hydrocarbons or flammable products with the unit.



Mixing an alkaline with an acid may result in a chemical reaction. Overheating of the mixture may cause it to splatter caustic compounds or release hazardous fumes, gas and vapors. Always flush the unit with fresh water thoroughly when switching from an alkaline to an acid or an acid to an alkaline.

NOTICE

Servicing or modifying this unit with parts not listed in this manual may cause the unit to operate improperly. Do not use unauthorized parts when servicing the unit.

Use of an air lubricator before the unit may result in diminished performance and damage to the unit. Do not use an air lubricator before the unit.

Moisture in the air lines will damage the pump and diminish the pump life. The air must be filtered, clean, dry and free of moisture. If needed, install an air dryer before the unit.

PROTECT THE ENVIRONMENT



Please dispose of packaging materials, old machine components, and hazardous fluids in an environmentally safe way according to local waste disposal regulations

Product Overview

Requirements

Compressed air requirements	40-80 psi (2.8-5.5 bar) with 5-10 CFM (141.6-283.2 l/min)
Liquid temperature range	40-100°F (4.4-37.8°C)
Chemical compatibility	Chemical products used with this equipment must be formulated for this type of application and compatible with unit materials and pump seals. For more information on chemical compatibility, consult the manufacturer or SDS for your product or contact our customer service department.

Specifications

Power type	Compressed air
Chemical pickup type	Draws from pre-mixed solution
Number of products unit can draw from	One product
Suction line length/diameter	3.5 ft. (1 m) hose with 3/8 in. (12.7 mm) inside diameter
Capacity	5 gallons (113.6 liters)
Discharge line length/diameter	20 ft. (6.1 m) hose, with 1/2 in. (19 mm) inside diameter
Discharge wand/tip type	7 in. (17.8 cm) stainless steel wand with zero tip and ball valve
Output distance	15-20 ft. (4.6-6.1 m)
Output volume	15-30 gal/min (56.8-113.6 l/min)
Flow rate*	2-2.3 gal/min (7.6-8.7 l/min)
Pump seals	Santoprene, Viton, or Kalrez
Wheel type	Two 4 inch (10.2 cm) non-marking wheels

*Flow rates given are based on chemical with viscosity of water and factory air pressure settings.

Product Components

Get to know the FI-5N components that you will need to use, adjust or assemble.

Back plate assembly • Inside view

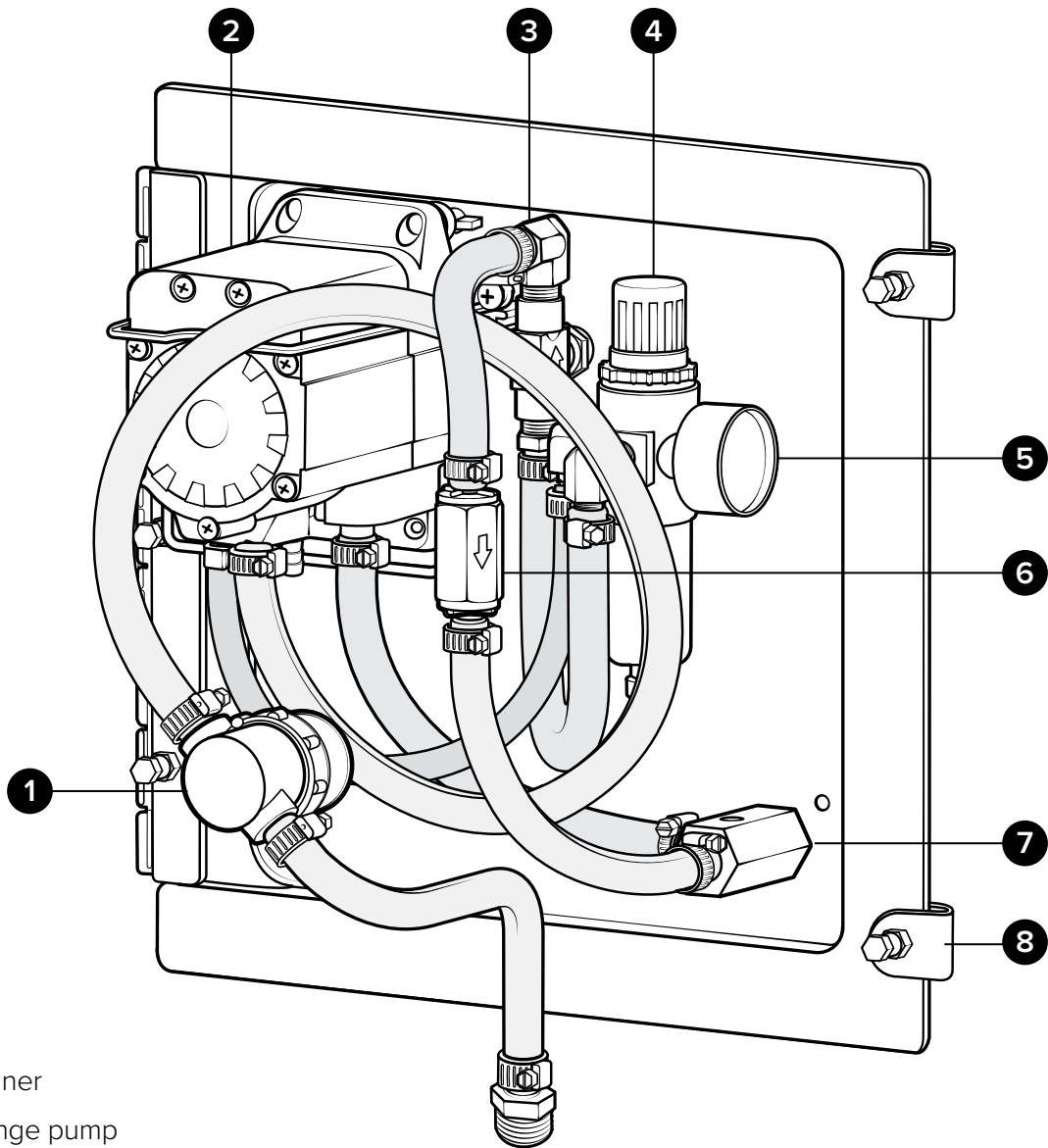

1. In-line strainer
2. Quick-change pump
3. Needle valve
4. Air regulator
5. Air pressure gauge
6. Check valve
7. Tee assembly
8. Back plate thumb nuts

Tank Assembly

Front view

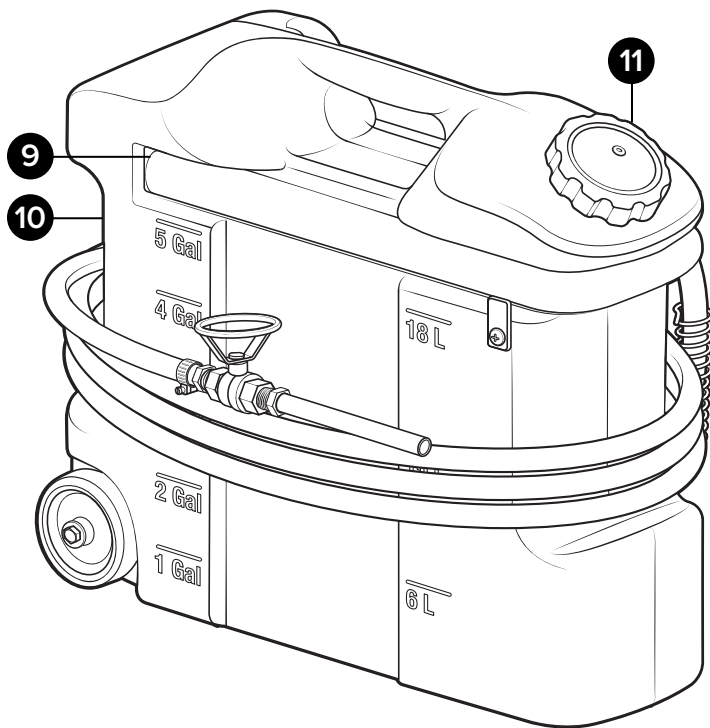

Back view

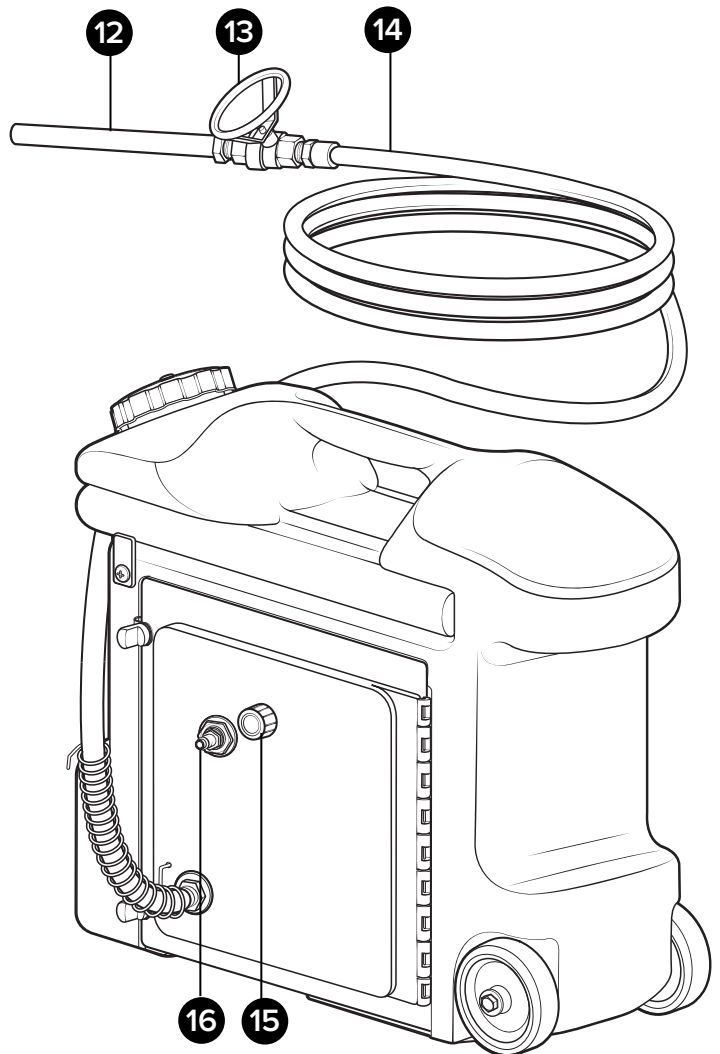

- 9. Handle
- 10. Solution tank
- 11. Cap
- 12. Discharge wand
- 13. Discharge ball valve
- 14. Discharge hose
- 14. Discharge wand
- 15. Needle valve
- 16. Air fitting

Using your unit

Operating Instructions

1. Following all instructions from chemical manufacturer, fill the solution tank with pre-mixed solution.
2. Verify cap is securely tightened.
3. With the discharge ball valve in the closed position, plug an air line into the air fitting.
4. Slowly open the discharge ball valve to begin foaming. Discharge ball valve should be completely open while foaming.
5. While the unit is running and discharging product, adjust the needle valve as needed to regulate the wetness or dryness of the foam following the steps below:
 - a. Close needle valve completely in clockwise direction.
 - b. Open needle valve in counter-clockwise direction 3 complete turns.
 - c. Continue to open needle valve in ¼ turn increments, allowing 30 seconds between adjustments, until desired consistency of foam is achieved.
6. Close the discharge ball valve to stop foaming.

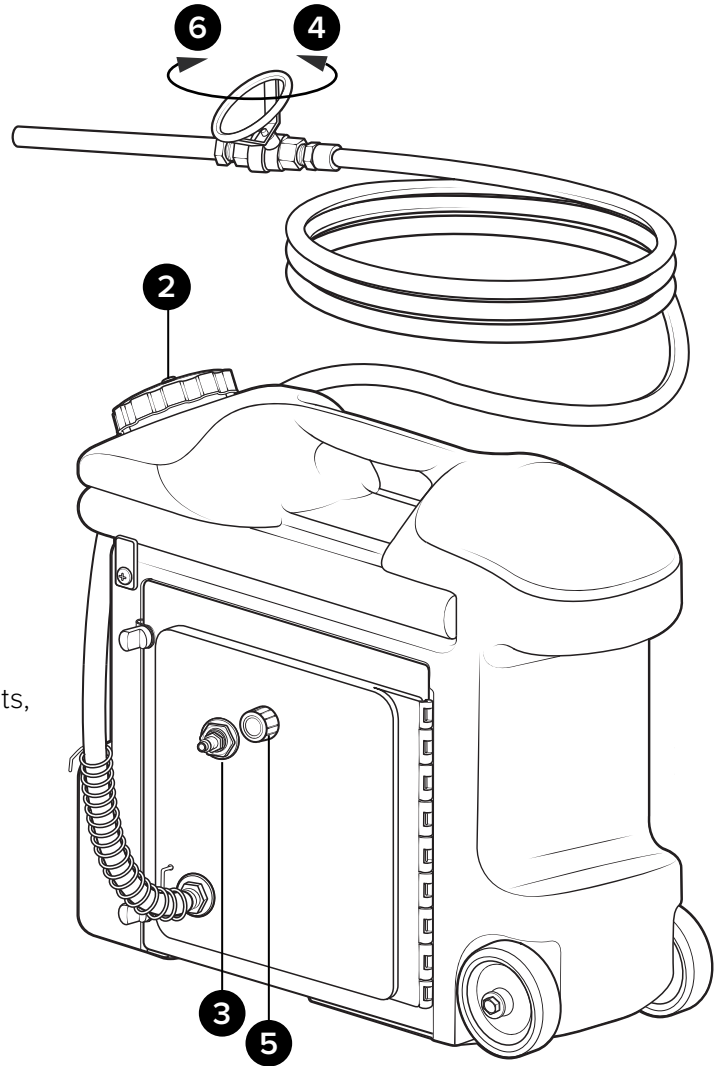

After Use Instructions

NOTE: For proper handling and disposal procedures refer to chemical SDS.

7. Solution should be removed from unit after each use. This can be done in two ways:
 - a. Unthread drain plug from front of tank and drain solution into approved location.
 - b. Place discharge wand into approved container to transfer remaining solution. Turn the needle valve to the wet setting and activate unit until all solution has been flushed from the system.
8. After solution has been removed, disconnect air line from the air fitting.
9. Open discharge ball valve to relieve remaining pressure.
10. Close ball valve after all pressure has been relieved. Store unit with discharge ball valve closed.
11. Before using unit with another chemistry, thoroughly flush with water.

Maintenance

WARNING

Performing any maintenance with the unit pressurized, and connected to the air supply may result in serious injury or death. Always ensure that the unit has been depressurized, and disconnected from the air supply before conducting any maintenance. Servicing or modifying this unit with parts not listed in this manual may cause the unit to operate improperly. Do not use unauthorized parts when servicing the unit.

Maintaining Your Unit

To keep your unit operating properly, periodically perform the following maintenance procedures:

- Inspect the pump for wear and leaks.
 - Inspect all hoses for leaks or excessive wear. Make sure all hose clamps are in good condition and properly secured.
 - Replace the filter located within the air regulator as needed. Clean by unthreading the air regulator bowl from the air regulator.
 - Check the suction line and strainer for debris. Clean as needed.
 - Drain your air compressor tank on a regular basis to help extend pump life. An air source with a high moisture content will accelerate pump wear.
- Note:** If your air source has a high moisture content, install a water separator to the air fitting on the backplate.

Servicing Your Unit

To service your unit, refer to the service manual which includes:

- Troubleshooting procedures.
- Detailed parts breakdowns and illustrations.
- Part numbers of serviceable components and assemblies.



Scan this code for
service manual

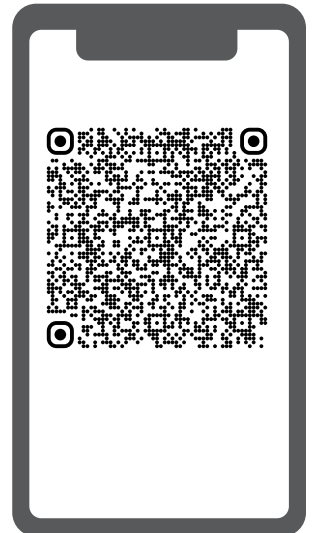

5 Gallon Foam Unit

Service Manual

FI-5N

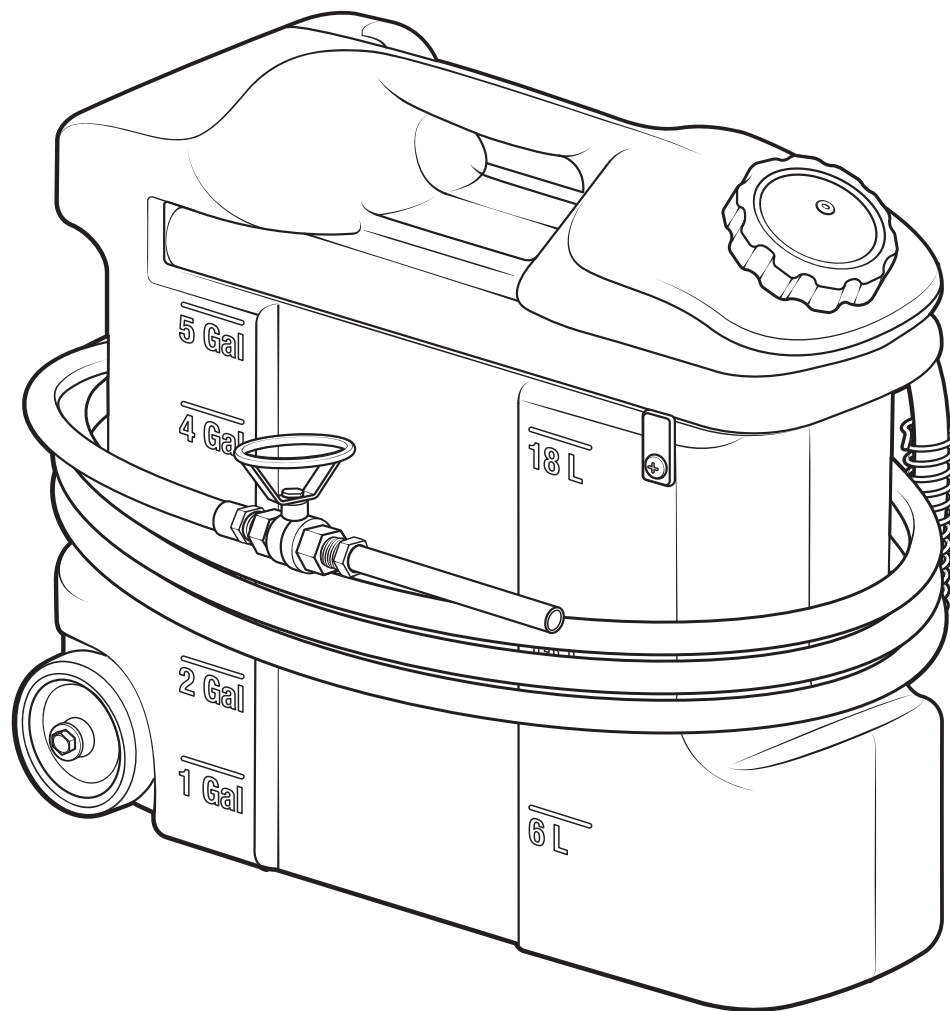

READ ALL INSTRUCTIONS BEFORE USING OR
SERVICING THIS UNIT. KEEP THIS MANUAL IN A
LOCATION THAT IS READILY AVAILABLE TO USERS
AND SERVICE TECHNICIANS.

English (Original Instructions)



Scan this code for
service manual



Safety

WARNING

PEOPLE OR OBJECTS CAN BE HURT OR DAMAGED IF THIS UNIT IS NOT USED CORRECTLY!



Failure to read all the instructions before operating the unit may result in personal injury or death from the improper use or the chemical solution. Anyone handling, operating or using the unit must read and understand the instructions in the manual. The buyer assumes all responsibility for safety and proper use in accordance with the instructions.



Using or servicing the unit without appropriate personal protective equipment (PPE) may result in serious injury such as burns, rashes, eye, throat or lung damage and death. Always wear PPE as indicated in the Safety Data Sheet (SDS) when using or servicing the unit. Protect eyes, skin, and lungs against drifting spray.



Chemical solutions may pose a health risk and death if they contact the skin or eyes, are inhaled or swallowed. Always read and follow all chemical safety precautions and handling instructions provided by the chemical manufacturer and the SDS associated with the chemical solution before using the unit.



Pressure within the equipment may cause an unexpected release of the chemical solution and cause serious injury such as burns, rashes, eye damage, throat or lung damage and death. Always depressurize and clean the unit after each use. Release any remaining air pressure by opening the discharge ball valve. Never leave the unit unattended while pressurized.

Using the unit with fluid temperatures above 100°F (37.8°C) may result in scalding, burns, serious injury or death. DO NOT use a solution with a temperature above 100°F (37.8°C).

Operating the unit when damaged or leaking may result in exposure to chemical solutions, serious injury or death. Never use the unit if it is damaged or leaking.

Never point the discharge wand at yourself, another person, or any object you do not want covered in chemical.



Using incoming air pressure exceeding 100 psi (6.9 bar) may result in pressure buildup, explosion, serious injury or death. DO NOT exceed 100 psi (6.9 bar) incoming air pressure when operating the unit.

Use of hydrocarbons and flammable products may result in explosions, fire and serious injury or death. Never use hydrocarbons or flammable products with the unit.



Mixing an alkaline with an acid may result in a chemical reaction. Overheating of the mixture may cause it to splatter caustic compounds or release hazardous fumes, gas and vapors. Always flush the unit with fresh water thoroughly when switching from an alkaline to an acid or an acid to an alkaline.

NOTICE

Servicing or modifying this unit with parts not listed in this manual may cause the unit to operate improperly. Do not use unauthorized parts when servicing the unit.

Use of an air lubricator before the unit may result in diminished performance and damage to the unit. Do not use an air lubricator before the unit.

Moisture in the air lines will damage the pump and diminish the pump life. The air must be filtered, clean, dry and free of moisture. If needed, install an air dryer before the unit.

PROTECT THE ENVIRONMENT



Please dispose of packaging materials, old machine components, and hazardous fluids in an environmentally safe way according to local waste disposal regulations.

Service Guide

⚠ WARNING

Performing any maintenance with the unit pressurized and connected to the air supply may result in serious injury or death. Always ensure that the unit has been depressurized and disconnected from the air supply before conducting any maintenance. Servicing or modifying this unit with parts not listed in this manual may cause the unit to operate improperly. Do not use unauthorized parts when servicing the unit.

Maintaining Your Unit

To keep your unit operating properly, periodically perform the following maintenance procedures:

- Inspect the pump for wear and leaks.
 - Inspect all hoses for leaks or excessive wear. Make sure all hose clamps are in good condition and properly secured.
 - Replace the filter located within the air regulator as needed. Clean by unthreading the air regulator bowl from the air regulator.
 - Check the suction line and strainer for debris. Clean as needed.
 - Drain your air compressor tank on a regular basis to help extend pump life. An air source with a high moisture content will accelerate pump wear.
- Note:** If your air source has a high moisture content, install a water separator to the air fitting on the backplate. See Page 7 for more details. (Back plate assembly)

Servicing Your Unit

Most repairs on the unit can be performed with the following tools:

- Crescent wrench (2x)
- $\frac{7}{16}$ in. (11 mm) open-ended wrench
- Flat head screwdriver
- Thread seal tape
- #2 Phillips head screwdriver
- #3 Phillips head screwdriver
- Hose cutters
- Knife

Troubleshooting Your Unit

If your unit is not operating properly, try using these troubleshooting tips:

Issue	Solution
Air regulator bowl or air filter has debris such as water, oil, or rust particles	<ul style="list-style-type: none"> • Clean by unthreading the air regulator bowl from the air regulator.
Pump is cycling improperly	<ul style="list-style-type: none"> • The needle valve is open too far. Close and readjust the needle valve as described in the operation section. • Ensure proper foaming chemical and concentration are being used.
Air passes through the pump without cycling	<ul style="list-style-type: none"> • The pump needs to be replaced.
The solution backs up into the air regulator bowl	<ul style="list-style-type: none"> • The check valve needs to be replaced.
Foam comes out wet, no matter where the needle valve is positioned	<ul style="list-style-type: none"> • Check for proper air pressure on the air gauge. The air regulator is factory set at 50 psi (3.4) bar. Operating range is 40 to 80 psi (2.8 to 5.5 bar) with 5 to 10 CFM (141.6 to 283.3 l/min). • The check valve may need to be replaced. • Verify correct chemical concentration is being used.
The unit operates at a reduced pressure	<ul style="list-style-type: none"> • Check suction line and strainer for debris or damage. Clean or replace as needed. To prevent damage to the unit, the strainer must always be used. • Check the air compressor supplying the unit. If the pressure is less than 40 psi (2.8 bar), turn off the unit until the compressor can catch up. • If the air supply is 50 psi (3.4 bar) or above, check the air gauge, which should read near 50 psi (3.4 bar). If the air gauge reads more or less than 50 psi (3.4 bar), adjust the pressure by turning the knob on the top of the air regulator. • Check if the stainless steel mixing mesh is plugged. Remove and clean it by following the instructions below: <ol style="list-style-type: none"> 1. Verify the unit is not plugged into an air supply and then relieve all stored pressure in the unit by turning the ball valve to the open position. 2. Remove discharge hose from hose barb on back of the unit. 3. Open back plate assembly and hold stainless tee with wrench to remove hose barb from tee fitting. 4. Remove the screen and the mixing mesh from inside the tee fitting. 5. Clean any particles from the mixing mesh and the screen. If the mixing mesh has a lot of foreign particles in it, make sure the suction strainer is still in place. 6. Replace the mixing mesh and screen into the back of the tee. Screw the stainless hose barb back into the tee. <p>NOTE: It is recommended to use a pipe thread sealant when reinstalling the stainless hose barb back into the tee fitting.</p>

Tank Assembly

Front view

TNKA-5N-BK:

5 gallon natural tank assembly - black* lid - includes handle, wheels, and backplate thumb nuts

BPTNA:

Back plate thumb nut assembly - includes bolt, thumbnut, and tether

Item number	Description
1	BST1420118-VS ¼-20 x 1 ⅝ in. set bolt - stainless - Vibra-Seal
2	TN1420 ¼-20 thumb nut - brass insert - assembled with tether

Item number	Description
3	JC35B Black* 3.5 in. one-way vented cap polypropylene - includes EPDM gasket and check valve
4	TNK-5N-HNDL Handle for 5 gallon tank
5	PTAB-TNK5N Tab for TNK-5N handle - HDPE
6	TNK-5N 5 gallon natural tank
7	HBSS1238 Stainless hose barb ½ MPT x ⅜ barb

* Additional colors available, see datasheet for options.

CSTA-5WHL:

5 in. caster wheel - includes bolt and washers

Item number	Description
8	B51618214-HH ⅝-18 x 2 ¼ in. bolt - stainless - hex head
9	CST5-WHL Wheel - polypro - for CST5SS and CST5SS-L
10	FW3816 Flat washer for ⅜-16 bolt - stainless - 0.41 in. id x 0.88 in. od x 0.05 in. thk

BPTNA

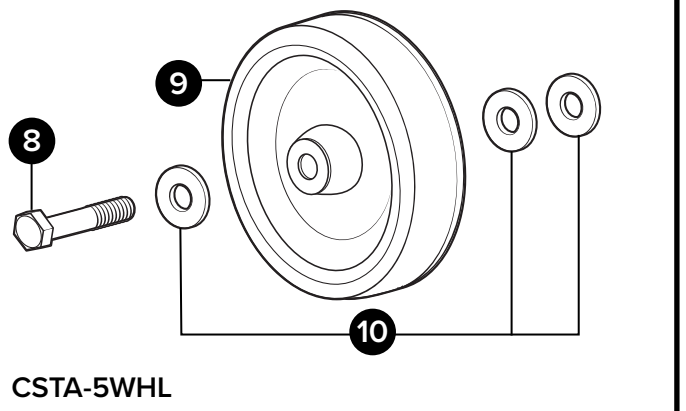
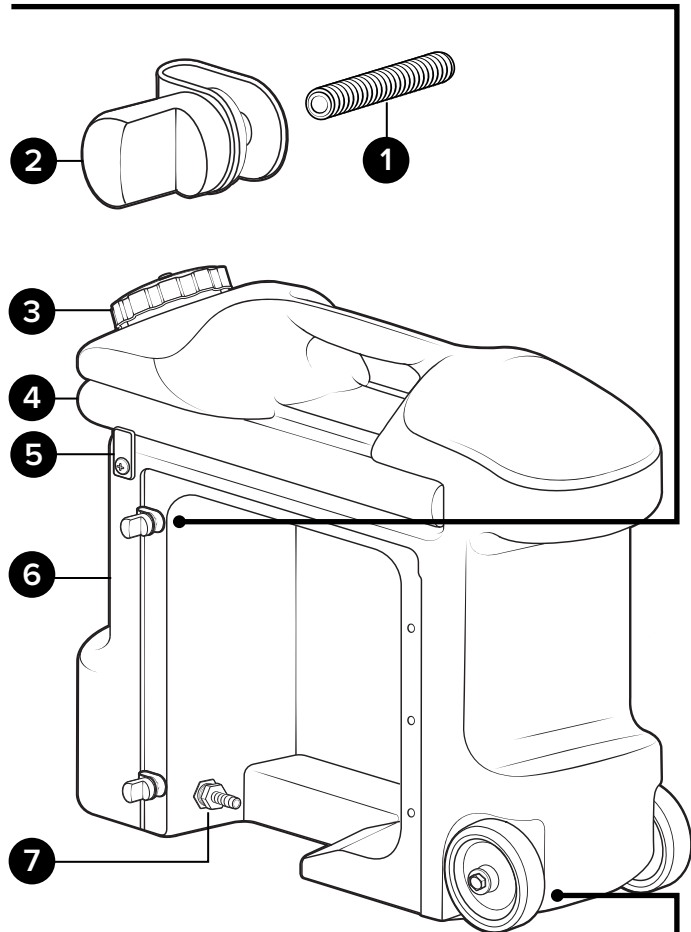

CSTA-5WHL

Back Plate Assembly

Inside view

PA-PF12:

Plate assembly for portable foam units with 1/2 in. hose - Santoprene pump

Additional plate assembly pump options:

PA-PF12K: Kalrez pump

PA-PF12V: Viton pump

Item number	Description
1 A P56	Pump with Santoprene seals - includes hose barbs, air fitting, and exhaust barb
B P56K	Pump with Kalrez seals - includes hose barbs, air fitting, and exhaust barb
C P56V	Pump with Viton seals - includes hose barbs, air fitting, and exhaust barb
2 NV14	Needle valve - 1/4 in. NPT - includes black knob
3 R25	Air regulator - two 1/4 in. FPT ports - two 1/8 in. FPT ports - includes filter and bowl
4 AG100	Air gauge - 1/8 in. NPT - 100 PSI dry model
5 CV38-AP	Check valve - 3/8 in. barbs - PVC body - Hastelloy spring - Teflon ball - white
6 SSC38	Stainless screw band clamp for 3/8 in. hose
7 SST12HB38A-MX	Stainless tee assembly - 1/2 in. FPT x 3/8 in. barb - includes mixing material and screen
8 STR38-IL	In-line strainer - 3/8 barb - EPDM gasket - 20 mesh SS - black bowl
9 H14BL-F	1/4 in. blue hose - hybrid TPE - available per ft.
10 H38BL-F	3/8 in. blue hose - hybrid TPE - available per ft.

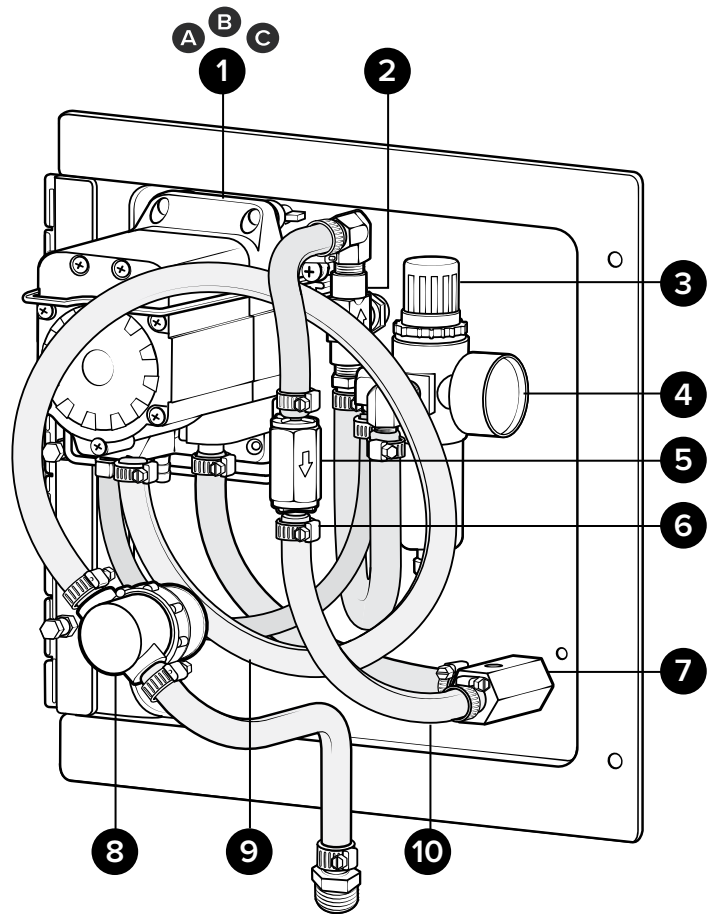

Back Plate Assembly

Back view

PA-PF12:

Plate assembly for portable foam units with 1/2 in. hose - Santoprene pump

Additional plate assembly pump options:

PA-PF12K: Kalrez pump

PA-PF12: Viton pump

Item number	Description	
1	NV14-HNDL	Black knob for needle valve
2	SSSFN12	Serrated flange nut - stainless - 1/2 in.
3	SSA14BKH	Bulkhead adapter - stainless - 1/4 NPT x 1/4 NPSM
4	AP14	Air fitting 1/4 MPT x plug - nickel-plated brass
5	FW12NPT	Flat washer for 1/2 in. NPT - stainless - 0.88 in. id x 1.5 in. od x 0.05 in. thk
6	HBSS1212	Stainless hose barb 1/2 MPT x 1/2 barb

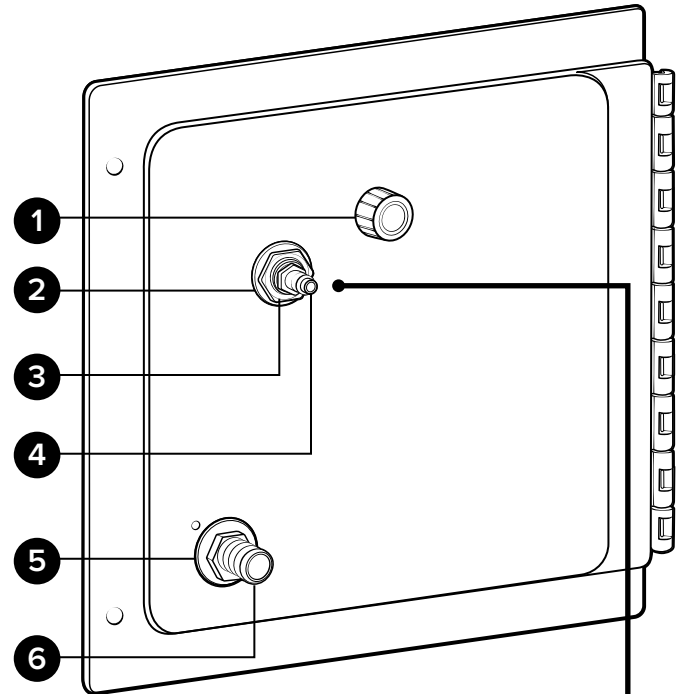

Optional Components

WSA-20CFM:

Water separator assembly - 20 CFM - 1/4 in. FPT ports - includes air plug and union fittings

Item number	Description	
7	SN1414	Stainless hex nipple 1/4 MPT x 1/4 MPT
8	SSU14	Stainless steel union - 1/4 in. FPT
9	WS-20CFM	Water separator - 20 CFM - 1/4 in. FPT ports
10	AP14	Air fitting 1/4 MPT x plug - nickel-plated brass

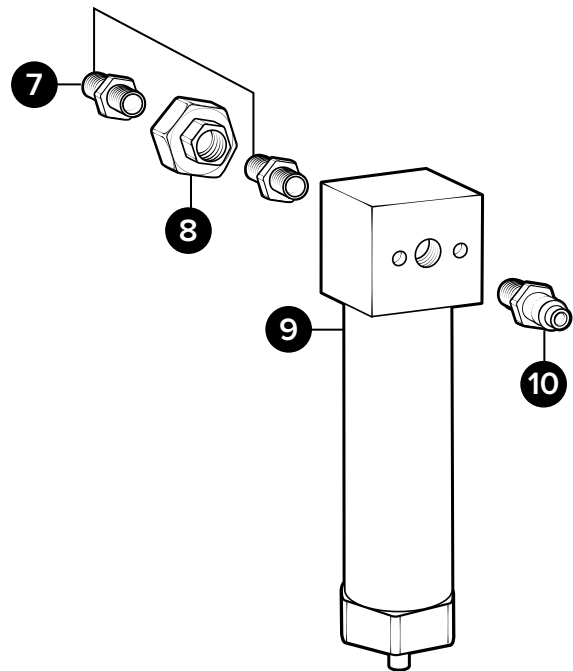

WSA-20CFM*

*Optional assembly sold separately

Back Plate Sub-assemblies

NVA-NV14-PF:

Needle valve assembly for portable foam units - includes hose barbs, and screw band clamps

Item number	Description
1 HBSEL1438	Stainless hose barb ¼ MPT x ⅜ barb elbow
2 NV14-HNDL	Black knob for needle valve
3 NV14	Needle valve - ¼ in. NPT - includes black knob
4 HBSS1438	Stainless hose barb ¼ MPT x ⅜ barb
5 SSC38	Stainless screw band clamp for ⅜ in. hose

SST12HB38A-MX:

Stainless tee assembly - ½ in. FPT x ⅜ in. barb - includes mixing material and screen

Item number	Description
6 SST12HB38	Stainless tee ½ FPT ⅜ barb - no mixing material
7 MXA- PF	Mixing material assembly - includes stainless mesh and screen

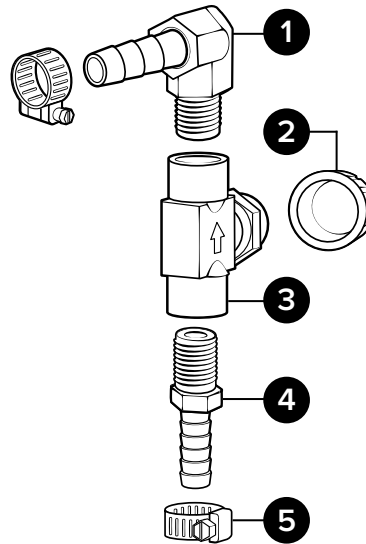
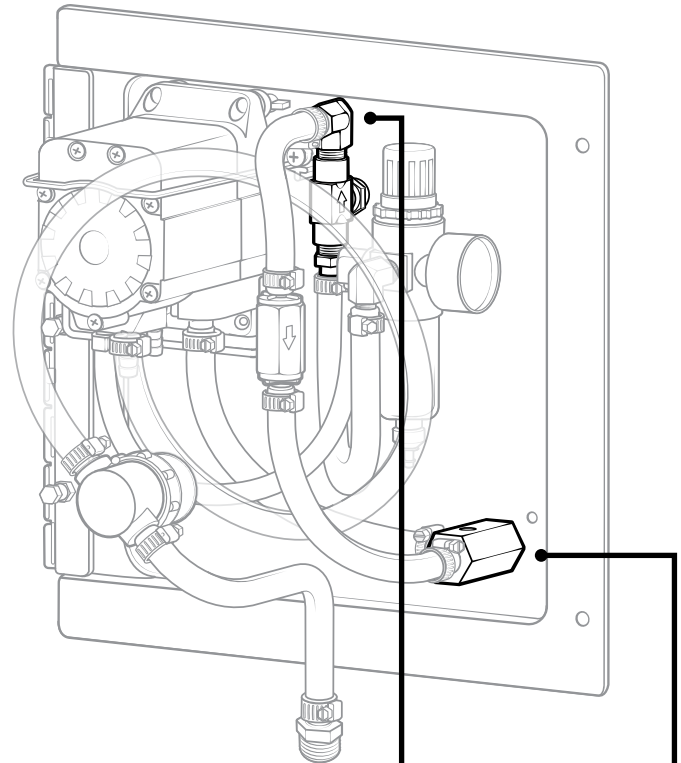

NVA-NV14-PF

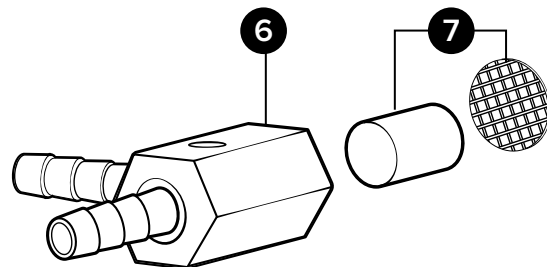

SST12HB38A-MX

Back Plate Sub-assemblies

RGA-R25-PF:

Air regulator assembly for portable foam units - includes air gauge, pump barb, hose, bulkhead fittings, and air plug

Item number	Description
1	HBB14P ¼ in. hose barb - brass - for G57/P56 air fitting with o-ring
2	EC14 Oetiker clamp for ¼ in. hose
3	H14BL-F ¼ in. blue hose - hybrid TPE - available per ft.
4	HBSSSEL1814 Stainless hose barb ⅜ MPT x ¼ barb elbow
5	SSC38 Stainless screw band clamp for ⅜ in. hose
6	H38BL-F ⅜ in. blue hose - hybrid TPE - available per ft.
7	HBSSSEL1438 Stainless hose barb ¼ MPT x ⅜ barb elbow
8	R25 Air regulator - two ¼ in. FPT ports - two ⅜ in. FPT ports - includes filter and bowl
9	AG100 Air gauge - ⅜ in. NPT - 100 PSI dry model
10	SSA14BKH Bulkhead adapter - stainless - ¼ NPT x ¼ NPSM
11	SSSFN12 Serrated flange nut - stainless - ½ in.
12	AP14 Air fitting ¼ MPT x plug - nickel-plated brass

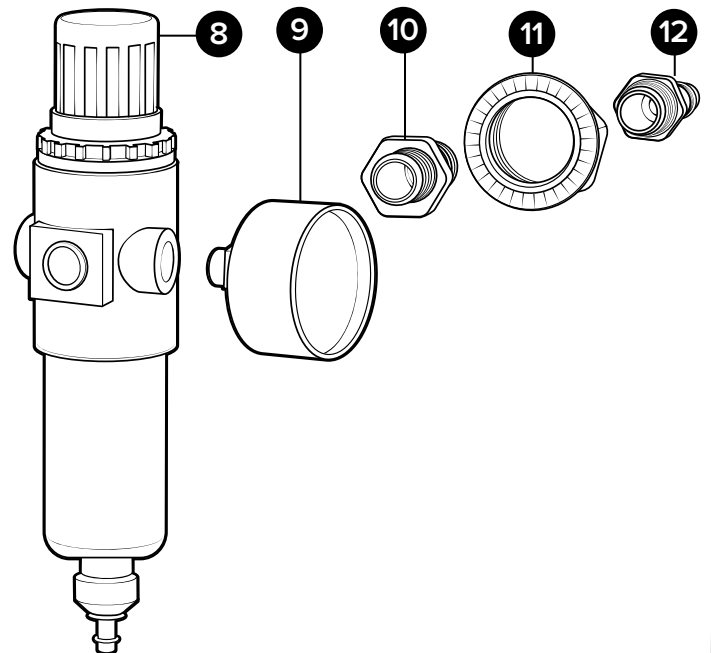
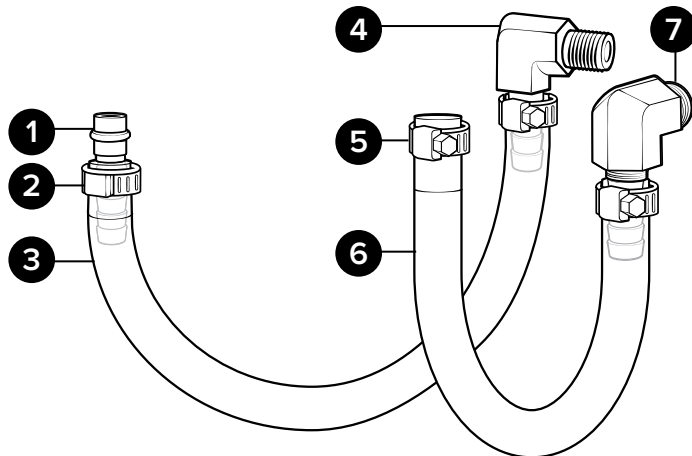
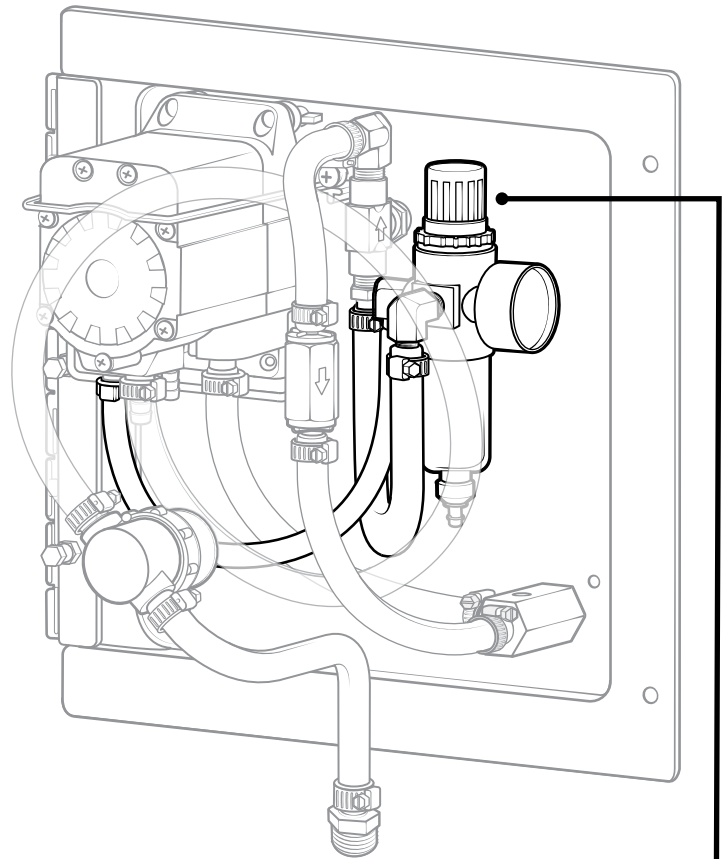

RGA-R25-PF

Suction Assembly

SCTNA-PF-TNK5:

Suction assembly for portable foam units - includes hose, in-line strainer, and pump hose barb - for Santoprene pump

Additional suction assembly options:

SCTNA-PFK-TNK5: Portables with Kalrez pump

SCTNA-PFV-TNK5: Portables with Viton pump

Item number	Description
1	A HB5638 Hose barb for P56 pump - EPDM o-ring
	B HB5638K Hose barb for P56K pump - Kalrez o-ring
	C HB5638V Hose barb for P56V pump - Viton o-ring
2	STR38-IL In-line strainer - 3/8 barb - EPDM gasket - 20 mesh SS - black bowl
3	SSC38 Stainless screw band clamp for 3/8 in. hose
4	H38BL-F 3/8 in. blue hose - hybrid TPE - available per ft.
5	HBSS1238 Stainless hose barb 1/2 MPT x 3/8 barb

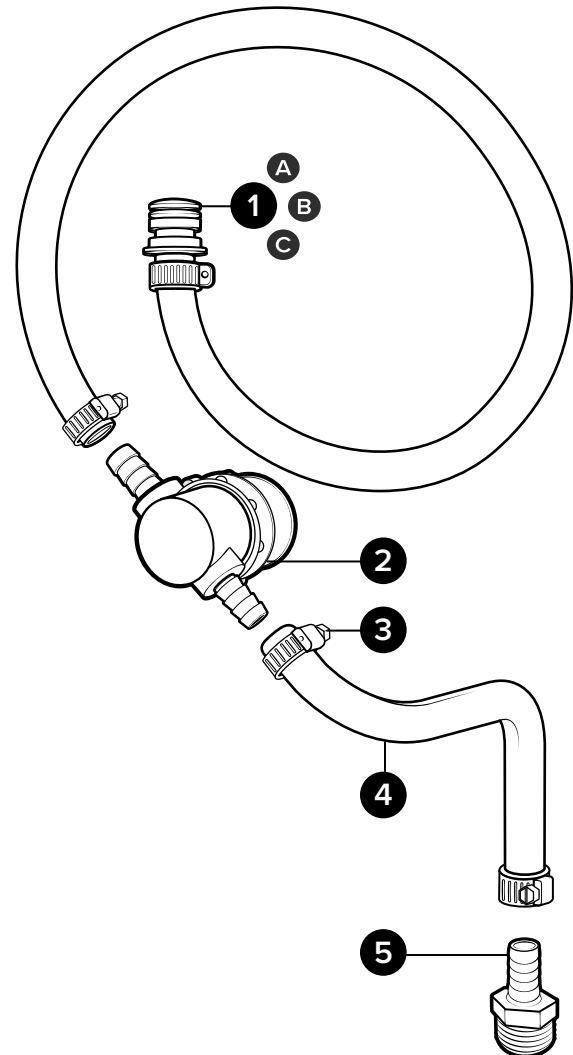
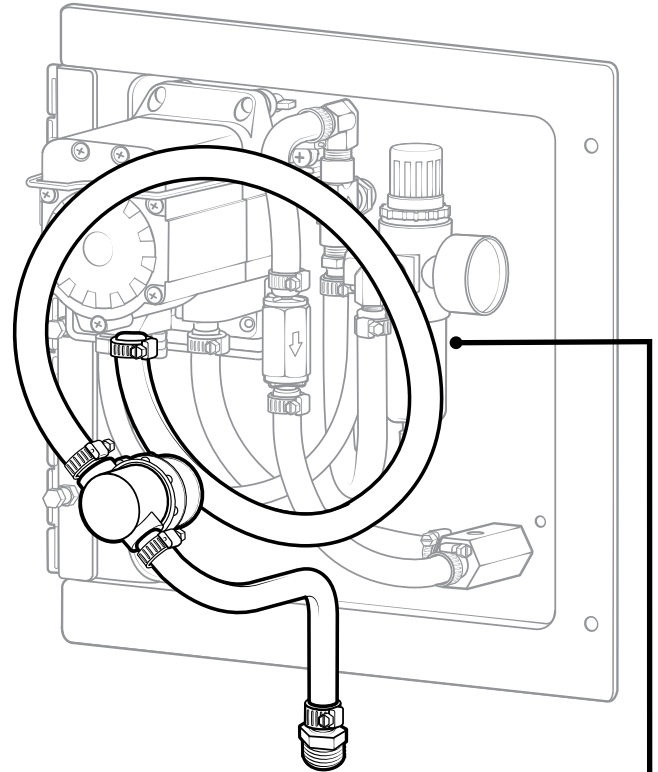

SCTNA-PF-TNK5

Hose Assembly

HA12BL-20:

Hose assembly - 20 ft. of ½ in. blue* hose - includes ferruled hose barb

Item number	Description	
1	HBSS1212	Stainless hose barb ½ MPT x ½ barb
2	SSC12	Stainless screw band clamp for ½ in. hose
3	H12BL-F	½ in. blue* hose - hybrid TPE - available per ft.

* Additional colors available, see datasheet for options.

AKSS12:

Stainless anti-kink spring for ½ in. hose

Item number	Description	
4	AKSS12	Stainless anti-kink spring for ½ in. hose

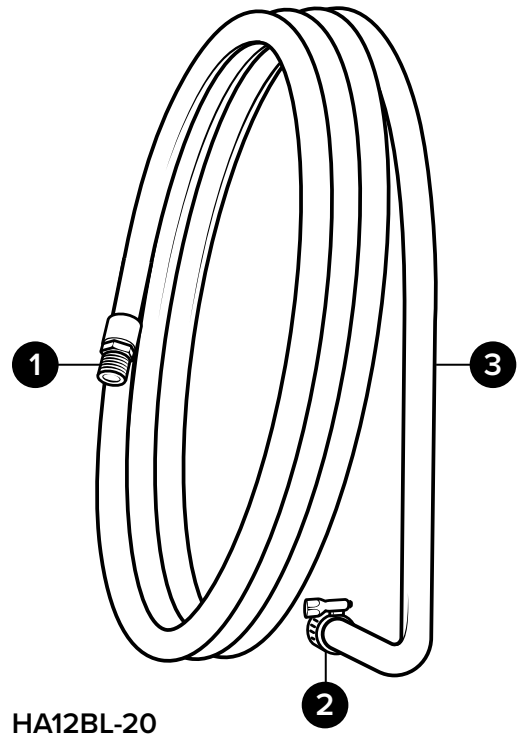
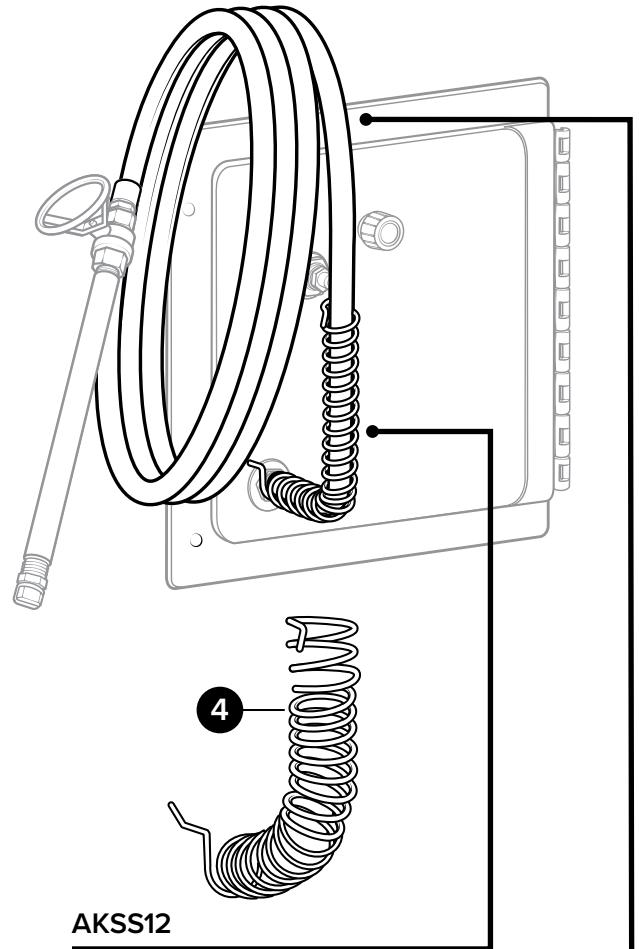

Wand Assembly Options

SSWA12:

Stainless wand assembly for 1/2 in. hose - 1/4 in. outlet

Item number	Description	
1	W147	Polished - SS wand 1/4 MPT toe - 7 in. long
2	HHSB1214	Hex head stainless bushing 1/2 MPT x 1/4 FPT
3	BVSS12	1/2 in. stainless ball valve - welded nut
4	HBSS1212	Stainless hose barb 1/2 MPT x 1/2 barb
5	SSC12	Stainless screw band clamp for 1/2 in. hose

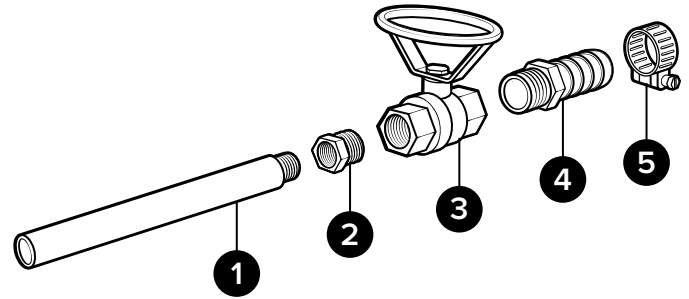

SSWA1210-ST:

Stainless wand assembly for 1/2 in. hose - 10 in. stainless wand - ST80100SS spray tip

Item number	Description	
6	ST80100SS	Spray tip - 80 degree - 10.0 GPM - stainless - 1/2 MPT
7	W1210FM	Stainless wand - 1/2 in. MPT x 1/2 in. FPT - 10 in. long
8	BVSS12	1/2 in. stainless ball valve - welded nut
9	HBSS1212	Stainless hose barb 1/2 MPT x 1/2 barb
10	SSC12	Stainless screw band clamp for 1/2 in. hose

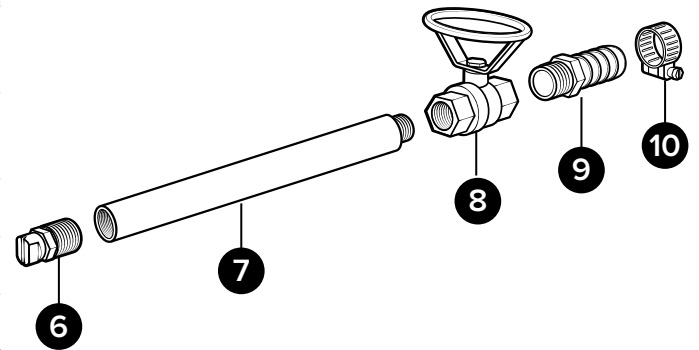

PWA1210-ST:

Poly wand assembly for 1/2 in. hose - 10 in. poly wand - ST80100SS spray tip

Item number	Description	
11	ST80100SS	Spray tip - 80 degree - 10.0 GPM - stainless - 1/2 MPT
12	PW12F10	1/2 in. FNPT and 1/2 in. FNPT wand - black polypropylene - 10 in. long
13	SN1212	Stainless hex nipple 1/2 MPT x 1/2 MPT
14	BVSS12	1/2 in. stainless ball valve - welded nut
15	HBSS1212	Stainless hose barb 1/2 MPT x 1/2 barb
16	SSC12	Stainless screw band clamp for 1/2 in. hose

