USER MANUAL

**MODEL NUMBER:
FI-5N-SM
FI-5NK-SM
FI-5NV-SM
AND RELATED UNITS**

5 Gallon Smart Foam Unit

English (Original Instructions)

U.S. Patent No. 10,076,760

READ ALL INSTRUCTIONS BEFORE OPERATING EQUIPMENT



Read this manual completely and understand the machine before operating or servicing it.

- Read all instructions before installing or operating unit.
- Always wear appropriate personal protective equipment (PPE) when operating or servicing unit.
- Always follow all chemical safety precautions and handling instructions provided by the chemical manufacturer and Safety Data Sheet (SDS).
- If this unit is modified or serviced with parts not listed in this manual, the unit may not operate correctly.
- Never point the discharge wand at yourself, another person, or any object you do not want covered in chemical.
- Always keep the air trigger port clean and free of blockages or debris. If the port becomes dirty or blocked, disconnect the compressed air source from the unit immediately and clean out the port before proceeding.
- Always keep the discharge hose free of kinks or obstructions.
- Always rinse and drain unit after use (as described in the After Use Instructions). Always store unit disconnected from the compressed air source.
- Do not exceed an incoming air pressure of 100 psi (7 bar).
- Do not exceed a fluid temperature of 100°F (37°C).
- Always flush the unit with fresh water thoroughly when switching from an alkaline to an acid or an acid to an alkaline.
- Only use clean and dry air. Air must be filtered and free of moisture or pump life will be diminished. If needed, install a water separator before the unit.
- Do not use an air lubricator before the unit.

PROTECT THE ENVIRONMENT

Please dispose of packaging materials, old machine components, and hazardous fluids in an environmentally safe way according to local waste disposal regulations.



Always remember to recycle.

*Specifications and parts are subject to change without notice.

OPTIONS		
	Pump Seal Material	
FI-5N	Santoprene (standard)	-SM
	Viton (V)	
	Kalrez (K)	
Add bold option codes to item number as shown. For standard options, no option code is needed. Examples: <ul style="list-style-type: none"> • FI-5N-SM (standard unit with Santoprene pump seals) • FI-5NV-SM (unit with Viton pump seals) 		

READ ALL INSTRUCTIONS BEFORE OPERATING EQUIPMENT

REQUIREMENTS	
Compressed air requirements	40-80 psi (3-5 bar) with 5-10 cfm (141-283 l/min)
Liquid temperature range	40-100°F (4.4-37°C)
Chemical compatibility	Chemical products used with this equipment must be formulated for this type of application and compatible with unit materials and pump seals. For more information on chemical compatibility, consult the manufacturer or SDS for your product or contact our customer service department.

SPECIFICATIONS	
Power type	Compressed air
Chemical pickup type	Draws from pre-mixed solution
Number of products unit can draw from	One product
Capacity	5 gallons (18.9 liters)
Discharge hose diameter/length	20 ft. (6.1 m) bonded hose, with 5/8 in. (15.9 mm) and 1/4 in. (6.4 mm) inside diameter
Discharge wand/tip type	Ultra high molecular weight (UHMW) polyethylene handle and wand extension, with 65 fan tip and built-in zero tip
Output distance	With zero tip: 8-12 feet (2.4-3.7 m) With fan tip: 8-12 feet (2.4-3.7 m)
Output volume	With zero tip: 20-32 gal/min (75.7-121.1 l/min) of foam With fan tip: 20-32 gal/min (75.7-121 l/min) of foam
Flow rate*	2 gal/min (7.6 l/min)
Pump seals	Santoprene, Viton, or Kalrez
Wheel type	Two 4 inch (10.2 cm) non-marking wheels

*Dilution rates and flow rates given are based on chemical with viscosity of water and factory air pressure settings.

READ ALL INSTRUCTIONS BEFORE OPERATING EQUIPMENT

Operation Instructions:

1. Follow all instructions from the chemical manufacturer. Fill the tank with water and the advised percentage of chemical concentrate.
2. Verify that the air trigger port is clean and free of blockages or debris, and the discharge hose is not kinked or obstructed.
3. With the wand pointed in a safe direction, connect an air line to the air inlet fitting.

Note: When you connect the air line, listen for any sound from the unit. If you hear the pump activate and begin to cycle, disconnect the air line immediately. This indicates that there is a blockage or other problem somewhere in the system, which could cause the unit to activate spontaneously. The problem must be addressed before proceeding (see “Troubleshooting Instructions”).

4. Place thumb over the air trigger to activate the unit and begin foaming.
5. While the unit is running and discharging product, adjust the needle valve as needed to regulate the wetness or dryness of the foam following the steps below:
 - a. Close needle valve completely in clockwise direction.
 - b. Open needle valve in counter-clockwise direction 2 complete turns.
 - c. Continue to open needle valve in ¼ turn increments, allowing 30 seconds between adjustments, until desired consistency of foam is achieved.
6. Release the air trigger to stop foaming.

Note: When you release the air trigger, the unit will shut off and depressurize. Foam that is already in the discharge hose may seep out, but no more foam will be created until you cover the air trigger again.

After Use Instructions:

1. Rinse the unit tank thoroughly with fresh water. Then fill the tank with fresh water.
2. Activate the unit and allow it to run until all chemical has been flushed from the system.
3. Disconnect the air line from the air fitting.
4. Allow any liquid remaining in the discharge hose to drain out through the discharge wand before storing the unit.

Maintenance Instructions:

To keep your unit operating properly, periodically perform the following maintenance procedures:

Note: Before performing any maintenance, ensure that the unit has been disconnected from the air supply according to the “After Use Instructions.” Also ensure that the unit tank is empty.

- Inspect the air pump for wear and leaks.
- Inspect all hoses for leaks or excessive wear. Make sure all hose clamps are in good condition and properly secured.
- Check the air trigger port on the handle for debris and clean as needed. When cleaning, be careful not to push debris into the port, as it may become lodged inside and create a blockage.
- Clean and replace the filter located within the air regulator as needed. Access the filter by unthreading the air regulator bowl from the air regulator.
- Check the suction line and strainer for debris or blockages, and clean as needed.
- Drain your air compressor tank on a regular basis to help extend pump life. An air source with a high moisture content will accelerate pump wear.

Note: If your air source has a high moisture content, you may wish to install a water separator before the unit.

READ ALL INSTRUCTIONS BEFORE OPERATING EQUIPMENT

Troubleshooting Instructions:

- Check to ensure that the discharge hose is uncoiled properly, and that there are no kinks that could obstruct fluid flow.
- Check the suction line and strainer for debris or damage. Clean or replace as needed. To prevent damage to the unit, the strainer must always be used.
- Check the air regulator bowl and air filter for debris such as water, oil, or rust particles. Clean by unthreading the air regulator bowl from the air regulator.
- If the needle valve is open too far, the pump may cycle improperly due to lack of air pressure. If this occurs, close and readjust the needle valve as described in the Operation Instructions.
- Make sure proper foaming chemical and concentration are being used.
- If air passes through the pump without cycling, the pump needs to be replaced.
- If solution backs up into the air regulator bowl, the check valve needs to be replaced.
- If foam comes out wet, no matter where the needle valve is positioned, the check valve may need to be replaced.
- Check for proper air pressure on the air gauge. The air regulator is factory set at 50 psi (3.4 bar). Operating range is 40 to 80 psi (3 to 5 bar) with 5 to 10 CFM (141.6 to 283.3 l/min).
- If the unit activates when the air trigger port is not covered:
 1. Verify that the air trigger port is clean and free of blockages or debris, and the discharge hose is not kinked or obstructed.
 2. If the problem persists, try bypassing the air trigger. To do this, disconnect the ¼ inch hose from the wand. Point the wand in a safe direction and connect an air line to the unit. Then, use your thumb or finger to seal the open port of the ¼ inch hose at the wand.
 - a. If the unit activates when you connect the air line, the valve block may need to be replaced.
 - b. If the unit does not activate when you connect the air line, the hose or wand assembly may need to be replaced.
- If the unit does not activate when the air trigger port is covered:
 1. Confirm the incoming air supply is consistently 50 psi (3.4 bar) on the air gauge.
 2. If the problem persists, the valve block may need to be replaced.
- If the unit operates at a reduced pressure:
 1. Check the air compressor supplying the unit. If the pressure is less than 40 psi, turn the unit off until the compressor can catch up.
 2. If the air supply is 50 psi (3.4 bar) or above, check the air gauge, which should read near 50 psi (3.4 bar). If the air gauge reads more or less than 50 psi (3.4 bar), adjust the pressure by turning the knob on the top of the air regulator.
 3. If the problem persists, the stainless steel mixing mesh inside the tee fitting could be plugged. Remove and clean the mesh following the instructions below:
 - a. Ensure that the unit has been flushed and disconnected from the air supply according to the "After Use Instructions." Also ensure that the unit tank is empty, and/or that the valve at the base of the suction line is closed.
 - b. Remove the stainless hose barb from the tee fitting).
 - c. The stainless steel mixing mesh is located inside the tee fitting. Remove the old mesh and the screen that holds it in place. If the mesh and screen are in good condition, they can be cleaned and re-used. If not, they should be replaced with new parts.
 - d. Insert the new mesh.
 - e. Insert the new screen. Make sure it is seated securely, but not bent or deformed.
 - f. Reconnect the hose barb to the tee fitting. Attach the ¾ inch hose to the hose barb and secure it with the screw band clamp.
 - g. If you found a lot of particles or blockages inside the mesh, check the suction line strainer to make sure it is in place and operating correctly.

READ ALL INSTRUCTIONS BEFORE OPERATING EQUIPMENT

**TANK ASSEMBLY
ITEM NUMBER: TNKA-5N-BK**

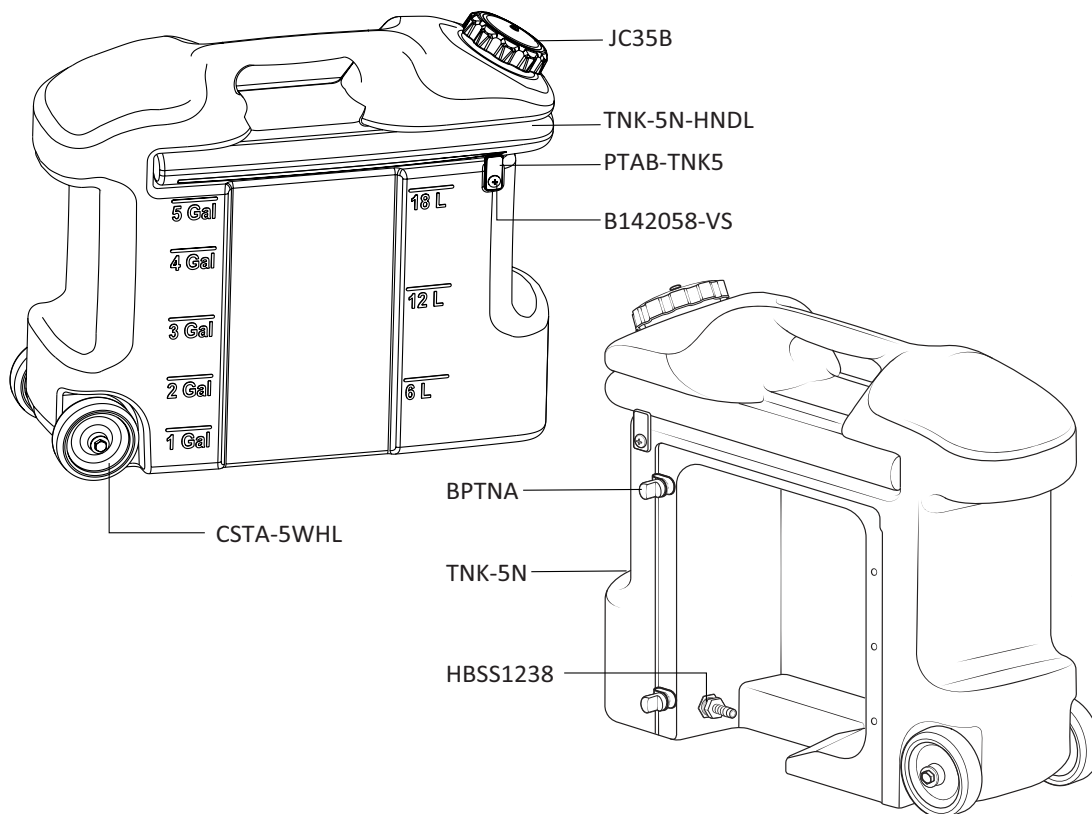

**WAND ASSEMBLY
ITEM NUMBER: SMWA**

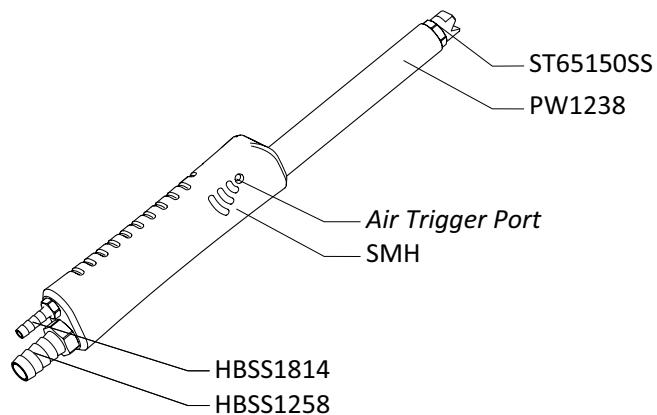

**DISCHARGE HOSE ASSEMBLY
ITEM NUMBER: H5814BL-20**

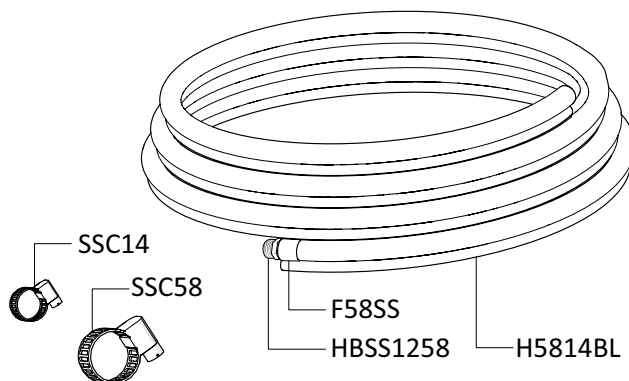

READ ALL INSTRUCTIONS BEFORE OPERATING EQUIPMENT

BACK PLATE ITEM NUMBER: PA-PF-SM

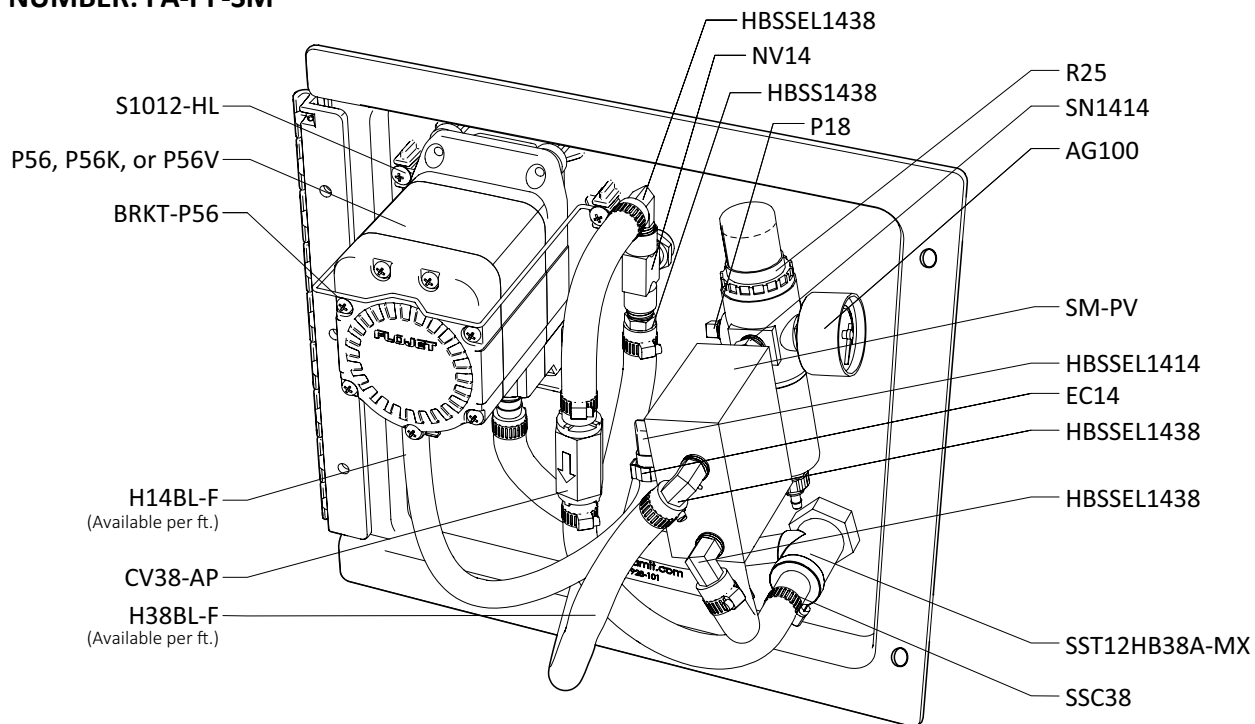

BACK PLATE Outside View

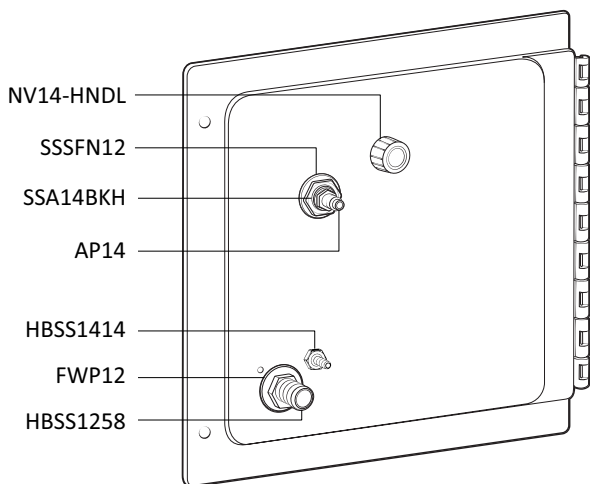

SUCTION ASSEMBLY

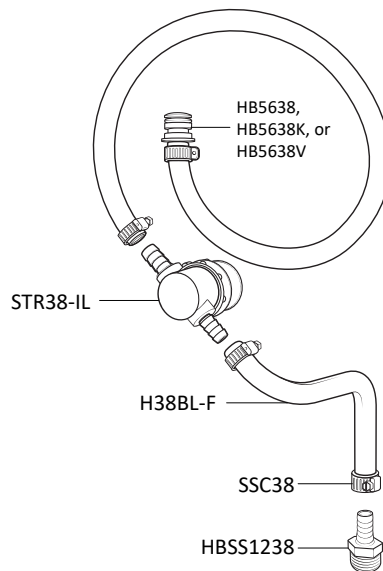

READ ALL INSTRUCTIONS BEFORE OPERATING EQUIPMENT

ITEM NUMBER	DESCRIPTION
AG100	AIR GAUGE - 1/8 IN. NPT - 100 PSI DRY MODEL
AP14	AIR FITTING 1/4 MPT X PLUG-NICKEL-PLATED BRASS
B142058-VS	1/4-20 X 3/8 IN. BOLT-STAINLESS-TRUSS HEAD PHILLIPS-VIBRASEAL
BPTNA	BACK PLATE THUMB NUT ASSEMBLY - INCLUDES BOLT, THUMB NUT, AND TETHER
<i>BST14201125-VS</i>	1/4-20 SET BOLT - 1.125 IN. LONG - VIBRA-SEAL
<i>TN1420</i>	1/4-20 THUMB NUT - BRASS INSERT - ASSEMBLED WITH TETHER
BRKT-P56	PUMP BRACKET- STAINLESS STEEL
CSTA-5WHL	5 IN. CASTER WHEEL - INCLUDES BOLT AND WASHERS
<i>B51618225</i>	8-8 STAINLESS STEEL HEX HEAD SCREW - BOLT
<i>CST5-WHL</i>	WHEEL - POLYPRO - FOR CST5 AND CST5-L
<i>FW38X78</i>	FLAT WASHER - .406 X .875 OD X .05 THK - 18-8 SS
CV38-AP	CHECK VALVE - 3/8 IN. BARBS - PVC BODY - HASTELLOY SPRING - TEFLON BALL - WHITE
EC14	OETIKER EAR CLAMP FOR 1/4 IN. HOSE
EC58	OETIKER EAR CLAMP FOR 3/8 IN. HOSE
FW58	FLAT WASHER FOR 3/8 IN. PIPE - STAINLESS - 0.687 ID X 1.5 OD X 0.07 THK
FWP12	3/8 ID X 1.5 OD X 0.05 THK SSFW
FWP14	C-816 1/2in SS WASHER
H14BL-F	1/4 INCH BLUE HOSE-HYBRID TPE-AVAILABLE PER FT.
H38BL-F	3/8 INCH BLUE HOSE-HYBRID TPE-AVAILABLE PER FT.
H5814BL	3/8 IN AND 1/2 IN BONDED BLUE HOSE- AVAILABLE PER FT
HBSEL1414	STAINLESS HOSE BARB 1/4 MPT X 1/4 BARB ELBOW
HBSS1238	STAINLESS HOSE BARB 1/2 MPT X 3/8 BARB
HBSS1258	STAINLESS HOSE BARB 1/2 MPT BY 3/8 BARB
HBSS1438	STAINLESS HOSE BARB 1/4 MPT X 3/8 BARB
HBSS1814	1/8 MPT X 1/4 STAINLESS HOSE BARB
HBSEL1438	STAINLESS HOSE BARB 1/4 MPT X 3/8 BARB ELBOW
JC35B	BLACK 3.5 IN. ONE-WAY VENTED CAP POLYPROPYLENE - INCLUDES EPDM GASKET AND CHECK VALVE
NV14	FLOW CONTROL VALVE - INCLUDES BLACK KNOB
<i>NV14-HNDL</i>	KNOB FOR 2839-1/4 NEEDLE VALVE
P18	PLUG 1/8 MPT HEX HEAD 304 SS
P56	PUMP WITH SANTOPRENE SEALS - INCLUDES HOSE BARBS, AIR FITTING, AND EXHAUST BARB

P56K	PUMP WITH KALREZ SEALS - INCLUDES HOSE BARBS, AIR FITTING, AND EXHAUST BARB
P56V	PUMP WITH VITON SEALS - INCLUDES HOSE BARBS, AIR FITTING, AND EXHAUST BARB
PLPF	PORTABLE FOAMER BACK PLATE W/ HINGE AND HOLES
PLPF-PIN	302 STAINLESS PORTABLE PLATE HINGE PIN
PTAB-TNK5	TAB FOR TNK-5N HANDLE - HDPE
PW1238	POLY WAND - 1/2 MPT X 3/8 FPT - UHMW
R25	AIR REGULATOR - TWO 1/4 IN. FPT PORTS - TWO 3/8 IN. FPT PORTS - INCLUDES FILTER AND BOWL
<i>AFR25</i>	AIR FILTER FOR R25
<i>ABR25</i>	METAL AIR BOWL FOR R25
S1012-HL	10-16 X 1/2 IN. SCREW-STAINLESS-HI LO
SC1212	S.S. COUPLER 1/2IN BY 1/2IN
SN1414	STAINLESS HEX NIPPLE 1/4 MPT X 1/4 MPT
SSA14BKH	BULKHEAD ADAPTER - STAINLESS - 1/4 NPT X 1/4 NPSM
SM-PV	PNEUMATIC VALVE FOR SMART TECHNOLOGY UNITS
SMH	HANDLE FOR BONDED HOSE - 1/2 in. FPT AND 3/8 in. FPT - UHMW
SSA14	SS304 MALE/FEMALE ADAPTOR 1/4 NPT X 1/4 NPT
SSC14	STAINLESS SCREW BAND CLAMP FOR 1/4 IN. HOSE
SSC38	STAINLESS SCREW BAND CLAMP FOR 3/8 IN. HOSE
SSC58	STAINLESS SCREW BAND CLAMP FOR 1/2 IN. HOSE
SSSFN12	SERRATED FLANGE NUT - STAINLESS - 1/2 IN.
SST12HB38A-MX	STAINLESS TEE ASSEMBLY - 1/2 IN. FPT X 3/8 IN. BARB - INCLUDES MIXING MATERIAL AND SCREEN
<i>SST12HB38</i>	STAINLESS TEE 1/2 FPT 3/8 BARB - NO MIXING MATERIAL
<i>MXA- PF</i>	MIXING MATERIAL ASSEMBLY-INCLUDES STAINLESS MESH, SCREEN
STR38-IL	IN-LINE STRAINER - 3/8 BARB - EPDM GASKET - 20 MESH SS - BLACK BOWL
ST65150SS	SPRAY TIP-65 DEGREE-15.0 GPM-STAINLESS-3/8 MPT
TNK-5N	5 GALLON NATURAL TANK
TNK-5N-HNDL	HANDLE FOR 5 GALLON TANK

NOTE: All products covered by this patent made for you under any license, should be marked with the notice "U.S. Patent No. 10,076,760"