



# VACUUM SEALER SU-310

Tabletop model. 10 m<sup>3</sup>/h. 320 mm.



## SALES DESCRIPTION

- 320 mm. sealing bar.
- 10 m<sup>3</sup>/h Busch vacuum pump.
- Vacuum controlled by sensor.

## FEATURES AND BENEFITS

- ✓ Powered by Busch.
- ✓ Vacuum controlled by sensor.
- ✓ Vacuum PLUS.
- ✓ LCD colour screen: all information at a glance.
- ✓ Backlit touch keyboard.
- ✓ Programmable: 25-programme memory. Blocking option.
- ✓ "Pause" button.
- ✓ Phased vacuum programme.
- ✓ Detection of the evaporation of liquids.
- ✓ Double seal.
- ✓ Cordless sealing bar.
- ✓ Progressive decompression.
- ✓ Vac-Norm ready with Automatic decompression.
- ✓ Stainless steel body and chamber. Deep-drawn chamber.
- ✓ Damped transparent lid of high durability polycarbonate.
- ✓ Dry-oil programme for drying the pump.
- ✓ Working hours counter for oil changes.
- ✓ Safety system with protection against vacuum failure.
- ✓ NSF-listed model.

## INCLUDES

- ✓ BUSCH pump.
- ✓ Sensor Controls.
- ✓ 25 programmable settings.
- ✓ Vacuum PLUS: up to 10 seconds of extra vacuum pull.
- ✓ Soft air function.
- ✓ Clear methacrylate lid.
- ✓ "PAUSE" function.
- ✓ Liquid detection system.
- ✓ Dry oil cycle.
- ✓ NSF Approved.
- ✓ Filling plate.

## ACCESSORIES

- Filling plates
- Liquid insert plates
- Vac-norm external vacuum kits
- Vac-norm containers
- Smooth bags for vacuum packing
- Thermal labels for CG2 printer
- RB Desktop printer for SU vacuum packing machines \*
- Thermal transfer labels for printer



**sammic** | www.sammic.com  
Food Service Equipment Manufacturer

Polígono Basarte, 1. phone +34 943 15 72 36  
20720 Azkoitia, Spain sales@sammic.com



Project	Date
Item	Qty
Approved	

FOOD PRESERVATION AND SOUS-VIDE  
VACUUM PACKING MACHINES - "SENSOR ULTRA" LINE

product sheet  
updated 05/09/2019



# VACUUM SEALER SU-310

Tabletop model. 10 m<sup>3</sup>/h. 320 mm.



## SPECIFICATIONS

Pump capacity: 10 m<sup>3</sup>/h  
 Bar length: 320 mm  
 Total loading: 370 W  
 Vacuum pressure (maximum): 2 mbar

### Internal dimensions

- ✓ Width: 330 mm
- ✓ Depth: 360 mm
- ✓ Height: 155 mm

### External dimensions (WxDxH)

- ✓ Width: 384 mm
  - ✓ Depth: 465 mm
  - ✓ Height: 403 mm
- Net weight: 39.5 Kg  
 Noise level (1m.): 75 dB(A)  
 Background noise: 32 dB(A)

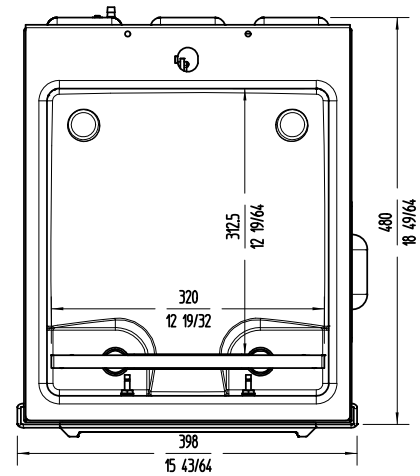
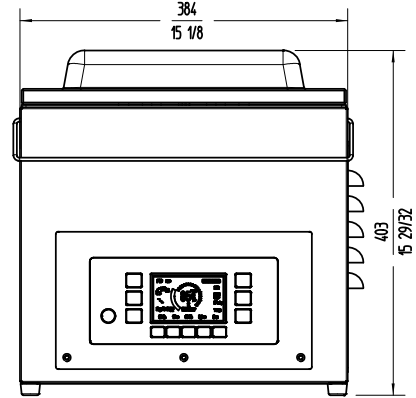
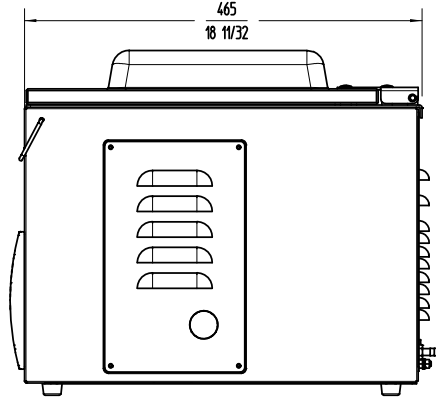

## AVAILABLE MODELS

- 1140730 Vacuum packing machine SU-310 230/50-60/1
- 1140731 Vacuum packing machine SU-310G 230/50-60/1
- 1140732 Vacuum packing machine SU-310P 230/50-60/1
- 1140733 Vacuum packing machine SU-310GP 230/50-60/1
- 1140735 Vacuum packing machine SU-310 120/50-60/1
- 1140736 Vacuum packing machine SU-310G 120/50-60/1
- 1140737 Vacuum packing machine SU-310P 120/50-60/1
- 1140738 Vacuum packing machine SU-310GP 120/50-60/1
- 1140739 Vacuum packing machine SU-310G+ 120/50-60/1
- 1140740 Vacuum packing machine SU-310GP+ 120/60/1

\* Ask for special versions availability

**sammic** | www.sammic.com  
 Food Service Equipment Manufacturer

Polígono Basarte, 1. phone +34 943 15 72 36  
 20720 Azkoitia, Spain sales@sammic.com



Project	Date
Item	Qty
Approved	

FOOD PRESERVATION AND SOUS-VIDE  
 VACUUM PACKING MACHINES - "SENSOR ULTRA" LINE

product sheet  
 updated 05/09/2019