



# PS-12 MEAT GRINDER

Hourly output: up to 100 Kg.



DYNAMIC PREPARATION  
COMMERCIAL MEAT GRINDERS



## FEATURES AND BENEFITS

Ideal for foodservice, communities and food retailers.

- ✓ Body and hopper in stainless steel.
- ✓ Mincing head blockage that ensures a perfect cut.
- ✓ Sturdy and ventilated motor.

## SALES DESCRIPTION

Motor unit and cutting unit in aluminium.

System: Enterprise.

1 knife and a Ø 6 mm. mesh plate included.

## INCLUDES

- ✓ Enterprise system, aluminium cutting unit.
- ✓ Ø 6mm. mesh plate.

## ACCESSORIES

- Mesh plates



**sammic** | [www.sammic.com](http://www.sammic.com)  
Food Service Equipment Manufacturer

Polígono Basarte, 1. phone +34 943 15 72 36  
20720 Azkoitia, Spain [sales@sammic.com](mailto:sales@sammic.com)



Project	Date
Item	Qty
Approved	

product sheet  
updated 02/08/2019



# PS-12 MEAT GRINDER

Hourly output: up to 100 Kg.



## SPECIFICATIONS

Production /hour (max): 100 Kg

Plate diameter: 70 mm

Inlet mouth diameter (1) : 45 mm

Electrical supply: 230 V / 1 ~

Total loading: 440 W

### External dimensions (WxDxH)

✓ Width: 227 mm

✓ Depth: 470 mm

✓ Height: 410 mm

Net weight: 17.3 Kg

Noise level (1m.): <70 dB(A)

Background noise: 32 dB(A)

IP Protection grade:21

### Crated dimensions

340 x 480 x 340 mm

Gross weight: 18.9 Kg.

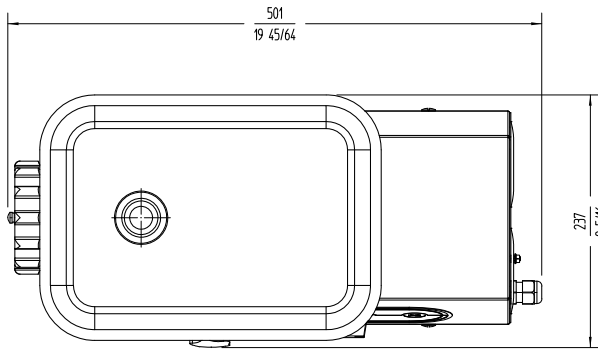
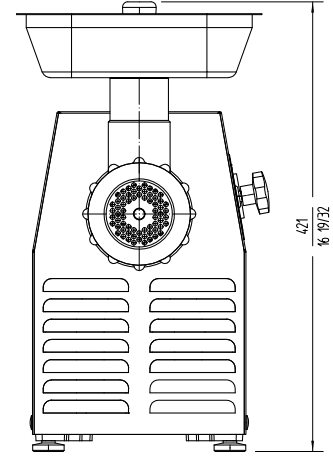
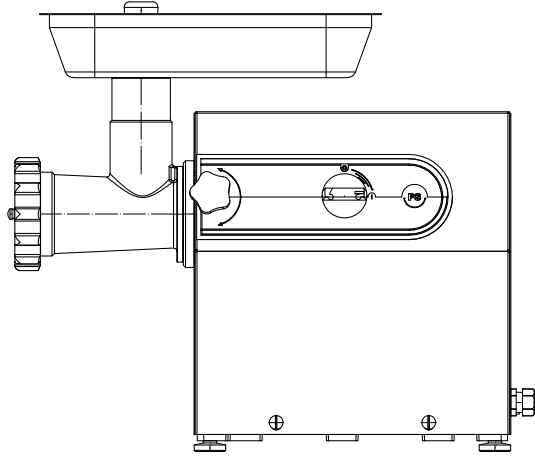

DYNAMIC PREPARATION  
COMMERCIAL MEAT GRINDERS

## AVAILABLE MODELS

1050110 Meat mincer PS-12 230/50/1

1050111 Meat mincer PS-12 220/60/1

\* Ask for special versions availability

**sammic** | [www.sammic.com](http://www.sammic.com)  
Food Service Equipment Manufacturer

Polígono Basarte, 1. phone +34 943 15 72 36  
20720 Azkoitia, Spain [sales@sammic.com](mailto:sales@sammic.com)



Project	Date
Item	Qty
Approved	

product sheet  
updated 02/08/2019