



COMMERCIAL ORANGE JUICER ECP

Lever operated citrus juice squeezer



FEATURES AND BENEFITS

- ✓ Stainless steel body.
- ✓ Lever operated.
- ✓ Easy to clean.

SALES DESCRIPTION

ACCESSORIES

- Outer strainer
- Stainless steel decanter



sammic | www.sammic.com
Food Service Equipment Manufacturer

Polígono Basarte, 1. phone +34 943 15 72 36
 20720 Azkoitia, Spain sales@sammic.com



Project	Date
Item	Qty
Approved	

SNACK BAR-PIZZERIA
COMMERCIAL ORANGE JUICERS

product sheet
updated 02/08/2019



COMMERCIAL ORANGE JUICER ECP

Lever operated citrus juice squeezer



SPECIFICATIONS

Production oranges/hour: 200

Total loading: 130 W

External dimensions (WxDxH)

✓ Width: 200 mm

✓ Depth: 300 mm

✓ Height: 370 mm

Net weight: 8 Kg

Noise level (1m.): 60 dB(A)

Background noise: 25 dB(A)

Crated dimensions

300 x 300 x 445 mm

Gross weight: 9.8 Kg.

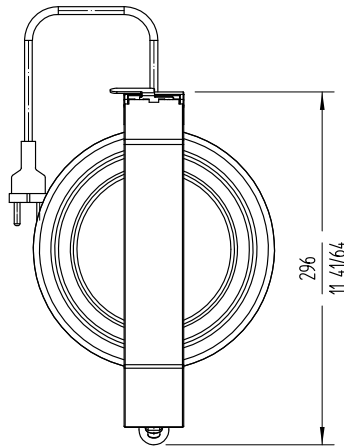
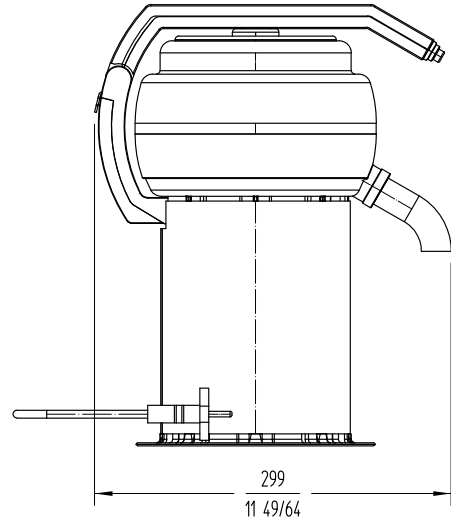
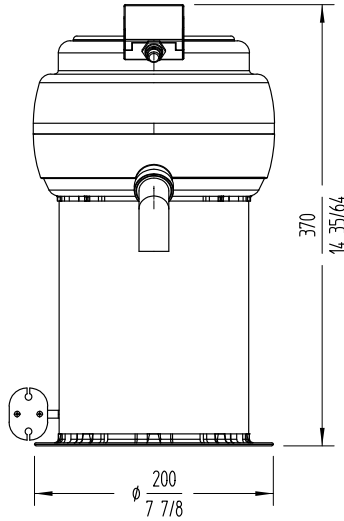

SNACK BAR-PIZZERIA
COMMERCIAL ORANGE JUICERS

AVAILABLE MODELS

3420033 Citrus juice extractor ECP 230/50/1

3420034 Citrus juice extractor ECP 120/60/1

3420035 Citrus juice extractor ECP 220/60/1

* Ask for special versions availability

sammic | www.sammic.com
Food Service Equipment Manufacturer

Polígono Basarte, 1. phone +34 943 15 72 36
20720 Azkoitia, Spain sales@sammic.com



Project	Date
Item	Qty
Approved	

product sheet
updated 02/08/2019