

**Family**  
COOKING EQUIPMENT STAR 90

**Section**  
GAS AND ELECTRIC GRILL

**Model**  
NG98G

**Code**  
CR0590700

## 80 MM GAS GRILL

Gas grill constructed in AISI 304 stainless steel. Reversible cast iron cooking grille. Forward sloping for cooking fatty meats, with 40 mm elements in direct contact and drip tray for collecting grease. Flat for cooking fish and vegetables with circular 10 mm diameter elements. 135 mm tall splashguard in AISI 304 stainless steel on three sides. Grease collection channel at front, easily removed for cleaning. Removable drawer for collecting cooking fats or holding water, positioned underneath the heating elements. The water allows the cooking fats to cool. Evaporation of water ensures grilled food will be tender. Controls positioned on fixed front control panel. Heating by means of burner in AISI 304 stainless steel positioned under the grille, protected by the AISI 316 stainless steel diffuser, easily removed for cleaning. Heat is adjusted by means of a safety tap with thermocouple and a pilot burner. Piezoelectric ignition. Scraper for grille supplied. Appliance equipped with height adjustable feet in stainless steel. IPX5 protection rating.



### Technical data

Width mm:	800	Internal dim. oven mm:	
Depth mm:	900	Oven capacity:	
Height mm:	870	Oven power kW:	
Weight kg.:	122.00	Qty heating zones:	2 x 11 kW
Volume m <sup>3</sup> :	1.00	Plate dim. mm:	632x627
Power supply:		Dim. heating zone mm:	
Gas power kW:	22.00	Qty tank:	
Electric power kW:		Tank dim. mm:	
		Tank capacity l:	

**Family**  
COOKING EQUIPMENT STAR 90

**Section**  
GAS AND ELECTRIC GRILL

**Model**  
NG98G

**Code**  
CR0590700

**80 MM GAS GRILL**

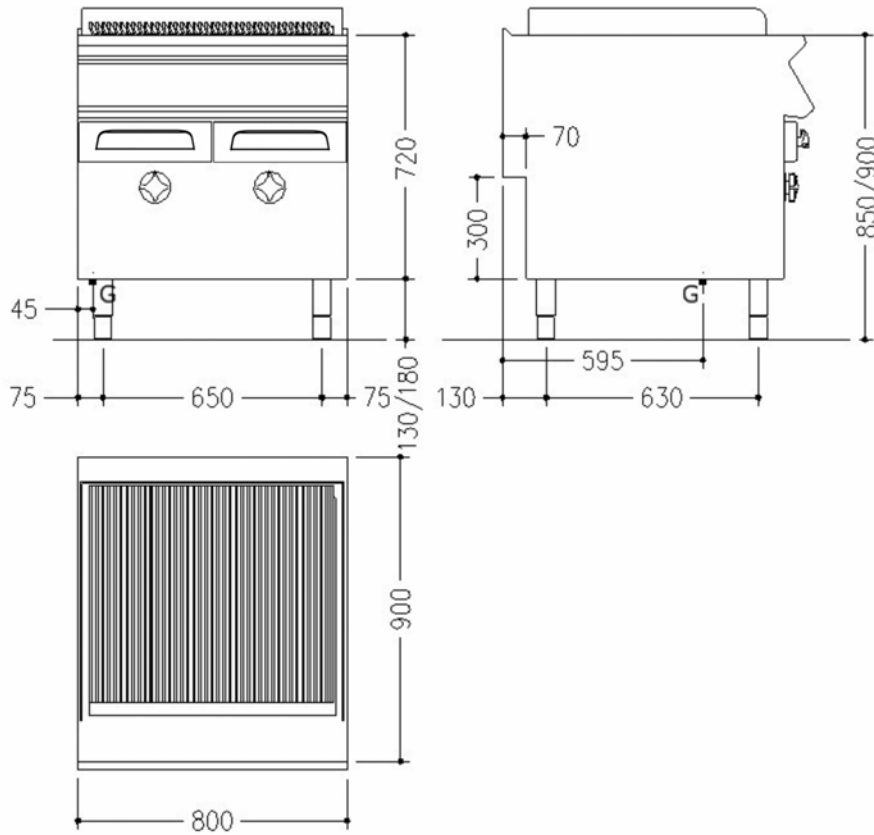

**Legend**

(E) Socket 1:

(E) Socket 2:

(G) Gas:  $\varnothing 1/2"$ - H=200mm

(AD) Softened water:

(AF) Cold water:

(AC) Hot water:

(S) Draining:

(FR) In e out freon:

(V) Steam: