

INSTALLATION GUIDE

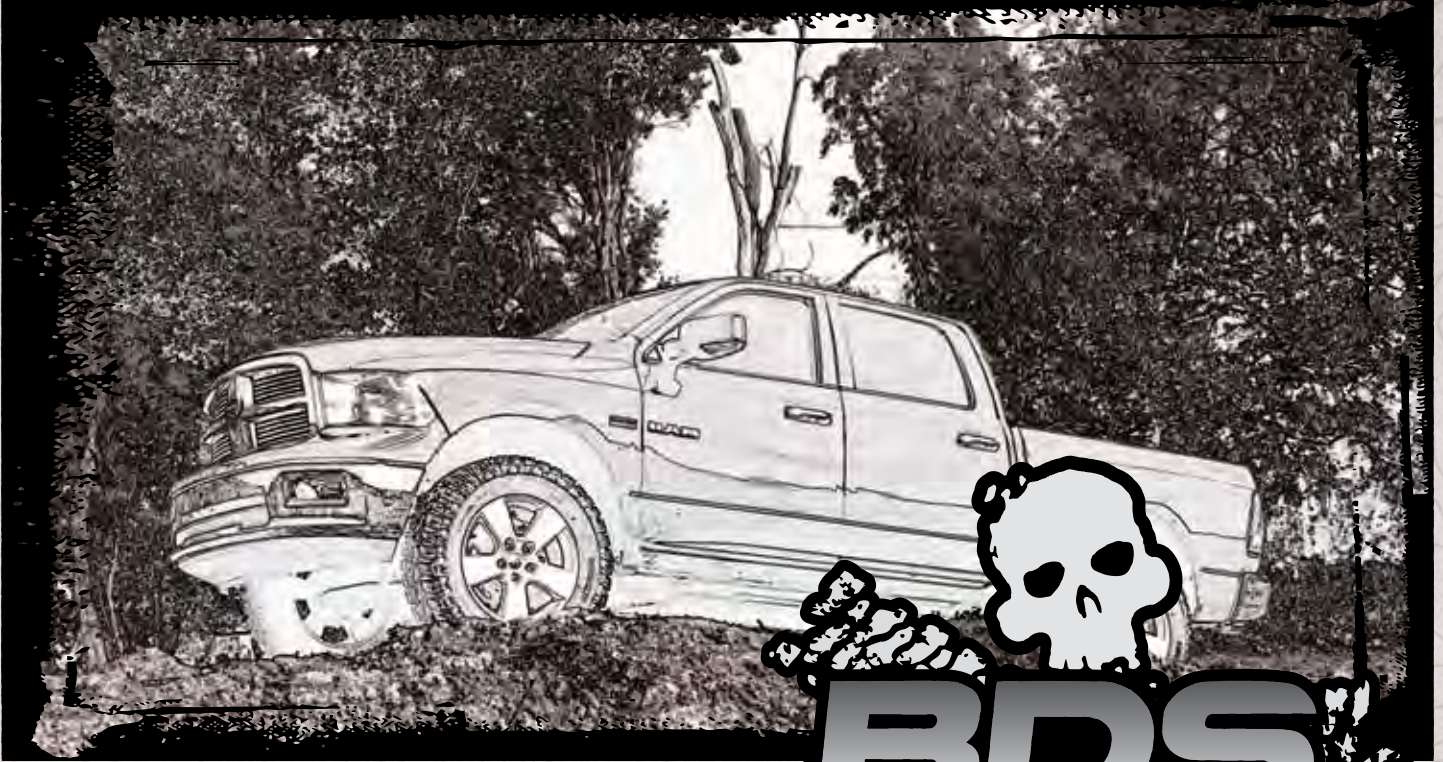

Part#: 012315



HARDCORE LIMITED LIFETIME WARRANTY

3" BDS Performance Suspension System

Ram 1500 4WD | 2019+

Rev. 052820

491 W. Garfield Ave., Coldwater, MI 49036 • Phone: 517-279-2135

Web: www.bds-suspension.com • E-mail: tech-bds@ridefox.com

Read And Understand All Instructions And Warnings Prior To Installation Of System And Operation Of Vehicle.

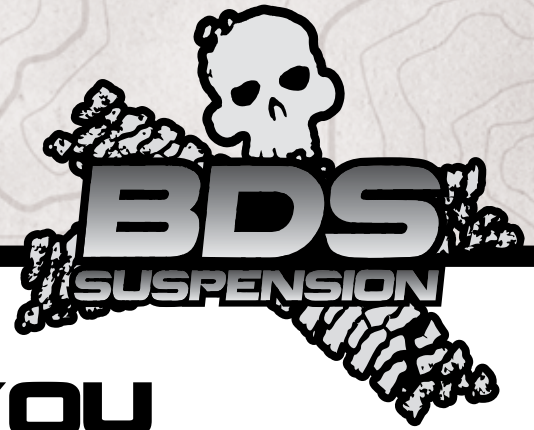

THANK YOU

Your truck is about to be fitted with the best suspension system on the market today. That means you will be driving the baddest looking truck in the neighborhood, and you'll have the warranty to ensure that it stays that way for years to come.

Thank you for choosing BDS Suspension!

BEFORE YOU START

BDS Suspension Co. recommends this system be installed by a professional technician. In addition to these instructions, professional knowledge of disassembly/ reassembly procedures and post installation checks must be known.

FOR YOUR SAFETY

Certain BDS Suspension products are intended to improve off-road performance. Modifying your vehicle for off-road use may result in the vehicle handling differently than a factory equipped vehicle. Extreme care must be used to prevent loss of control or vehicle rollover. Failure to drive your modified vehicle safely may result in serious injury or death. BDS Suspension Co. does not recommend the combined use of suspension lifts, body lifts, or other lifting devices. You should never operate your modified vehicle under the influence of alcohol or drugs. Always drive your modified vehicle at reduced speeds to ensure your ability to control your vehicle under all driving conditions. Always wear your seat belt.

BEFORE INSTALLATION

- Special literature required: OE Service Manual for model/year of vehicle. Refer to manual for proper disassembly/reassembly procedures of OE and related components.
- Adhere to recommendations when replacement fasteners, retainers and keepers are called out in the OE manual.
- Larger rim and tire combinations may increase leverage on suspension, steering, and related components. When selecting combinations larger than OE, consider the additional stress you could be inducing on the OE and related components.
- Post suspension system vehicles may experience drive line vibrations. Angles may require tuning, slider on shaft may require replacement, shafts may need to be lengthened or trued, and U-joints may need to be replaced.
- Secure and properly block vehicle prior to installation of BDS Suspension components. Always wear safety glasses when using power tools.
- If installation is to be performed without a hoist, BDS Suspension Co. recommends rear alterations first.
- Due to payload options and initial ride height variances, the amount of lift is a base figure. Final ride height dimensions may vary in accordance to original vehicle attitude. Always measure the attitude prior to beginning installation.



Visit 560plus.com for more information.

TIRES AND WHEELS

Works with stock rims with stock tires, or up to 12.50" wide tires on 17/18/20x9 w/ 4.5"-5" backsacing.



BEFORE YOU DRIVE

Check all fasteners for proper torque. Check to ensure for adequate clearance between all rotating, mobile, fixed, and heated members. Verify clearance between exhaust and brake lines, fuel lines, fuel tank, floor boards and wiring harness. Check steering gear for clearance. Test and inspect brake system.

Perform steering sweep to ensure front brake hoses have adequate slack and do not contact any rotating, mobile or heated members. Inspect rear brake hoses at full extension for adequate slack. Failure to perform hose check/ replacement may result in component failure. Longer replacement hoses, if needed can be purchased from a local parts supplier.

Perform head light check and adjustment.

Re-torque all fasteners after 500 miles. Always inspect fasteners and components during routine servicing.

CONTENTS OF YOUR KIT

012315 Box Kit		
Part #	Qty	Description
A301	1	UCA Assembly - DRV
02749	1	UCA - Drv
500-1134	1	Ball Joint
560-1098	2	Rubber Bushing
A302	1	UCA Assembly - PASS
02750	1	UCA - PASS
500-1134	1	Ball Joint
560-1098	2	Rubber Bushing
B1185	1	Bag Kit
02911	2	Ball Joint Cap
9452K145	2	O-ring (#139)
45NA53	1	Grease Packet
967	1	Bolt Pack - Brake Line Hardware
	2	Wire Clip
	2	1/4"-20 x 5/8" bolt grade 5 cz
	2	1/4"-20 serrated edge flanged nut
	2	1/4" SAE Clear Zinc Washer
032159R	2	Ram 1599 Rear Coil Spring

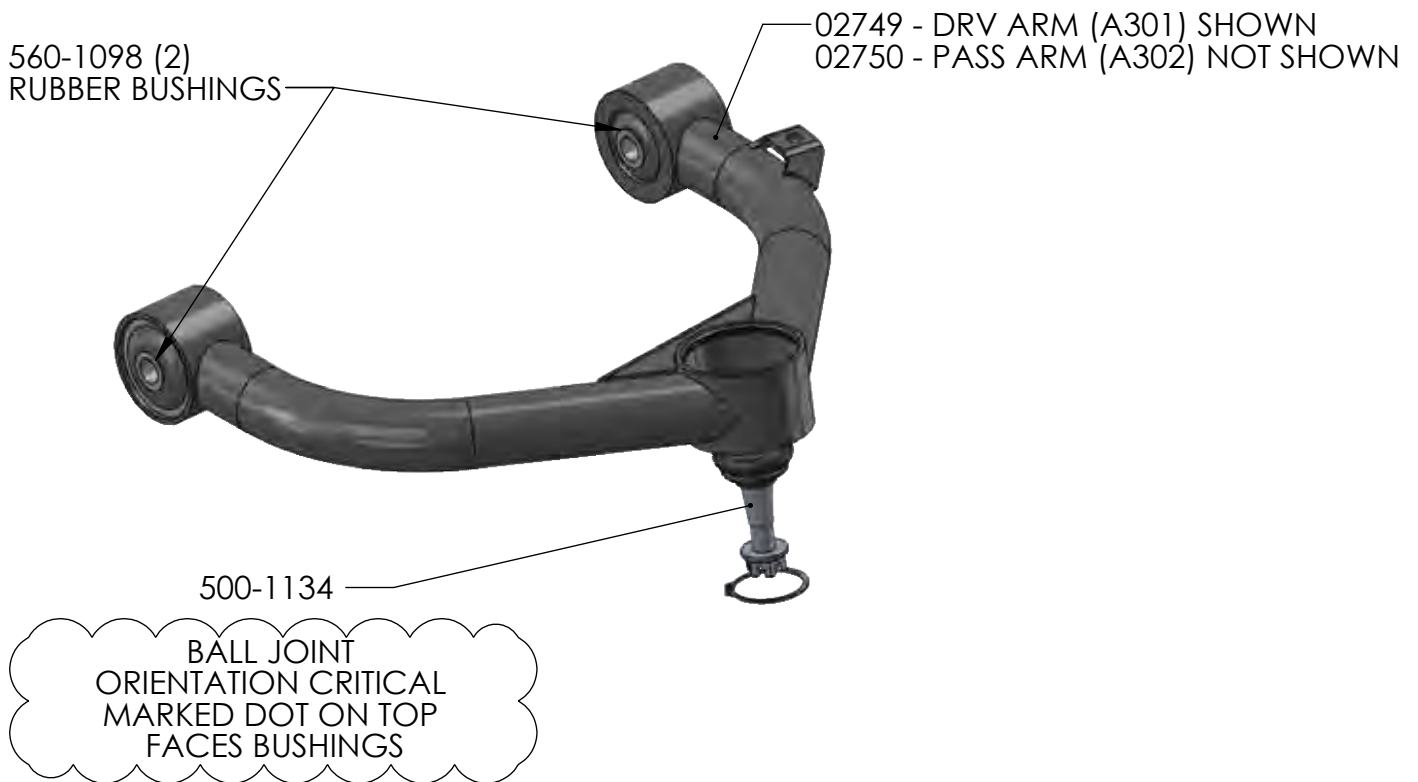

TECH TIPS

TROUBLESHOOTING INFORMATION FOR YOUR VEHICLE

1. Will not work with stock rims with a 12.50" wide tire, tire will rub the UCA at full steering lock. If the stock rim is reinstalled it will need to be with the stock size tire ONLY!
2. Ball joint used is 500-1134, use this for replacement purposes if a new ball joint is ever needed. Ball joint is directional and must be installed with the 'dot' facing either inward or outward on the vehicle, otherwise damage may occur.

INSTALLATION INSTRUCTIONS

INSTALLATION INSTRUCTIONS

1. Park vehicle on clean, flat, and level surface. Block the rear wheels for safety.
2. Raise the front of the vehicle and support the frame rails with jackstands.
3. Remove the front wheels.

SPECIAL TOOLS

Torque Wrench
8677 Chrysler Ball Joint Separation Tool (or Equiv)

FRONT DISASSEMBLY

4. Disconnect the sway bar links from the lower control arm. Leave the links attached to the sway bar. (Fig 1). Save hardware.

FIGURE 1



5. Disconnect both outer tie rod ends from spindle steering arm. Save hardware.
6. Disconnect both upper control arms from spindle steering arm. Be careful not to damage any electric wires or brake lines.
7. Support the lower control arm with a hydraulic jack. Remove the three strut-to-frame mounting nuts (Fig 5).

! Caution *DO NOT loosen the middle strut nut.*

FIGURE 2



8. Remove the (1) bolt and nut connecting the shock to the lower control arm. (Do not discard bolt and nut as it will be used with your new FOX coil-over kit)
9. Remove the stock shock assembly. You may need to use a pry bar to lower the suspension enough to remove the stock shock. Be careful not to damage any brake lines or electrical wires.
10. Disconnect the ABS wire from the upper control arm.
11. Remove the upper control arm from the vehicle. Do not hit the aluminum steering knuckle with a hammer to dislodge the upper ball joint taper. Chrysler manual recommends #8677 ball joint tool. (Fig 3) Failure to properly disassemble the ball joint may weaken the factory aluminum knuckle and cause premature failure.

FIGURE 3



COILOVER INSTALLATION

12. Install the new coil-over assembly. With remote reservoir models make sure that the hoses are facing outward and towards the front of the vehicle. (Fig.4) Connect the top shock hat to the vehicle using the bolts and washers provided or with Performance Series models connect the top shock hat to the vehicle using the nuts and washers provided. Tighten all three bolts/nuts to 24 ft-lbs. (you will need to remove the outer center bolt to install the reservoir bracket in step 14)

FIGURE 4



13. Connect the shock assembly to the lower control arm, reusing the stock bolt and nut. Leave hardware loose.
14. On the external reservoir models, install the reservoir bracket by placing on top of the vehicle coil-over bucket and align the bracket center hole with the outer center hole of the shock top hat, install supplied bolt and torque to 24 ft-lbs.
15. On the external reservoir models, install the reservoir onto reservoir bracket using two supplied clamps. Utilize the slots in the bracket to locate clamps. Do not feed clamps through the slots in the brackets.

CONTROL ARM INSTALLATION

16. Install new arm with factory hardware and new ball joint nut. Snug, but do not tighten the upper control arms at this time. Final torque will be done with the weight of the vehicle on the wheels. Tighten the upper ball joint nut to 65 ft-lbs. Do not loosen to get the cotter pin to install.

Note: Arms are side specific. The arms will have the ball joint offset towards the rear of the vehicle. The ABS tab will be towards the 'rear' of the vehicle.

17. Grease the upper ball joint at this time.
18. Use included grease packet to grease the o-ring, install o-ring onto upper ball joint cap. Press into the upper control arm with the palm of one's hand. (Fig 5)

FIGURE 5



19. Reconnect the sway bar on both sides to the lower control arm and torque the nut to 88 ft-lbs.
20. Reconnect the outer tie rod on both sides and torque to factory specifications
21. Reinstall wheels and torque to 130 ft-lbs in a crossing pattern.
22. Cycle the steering to check for adequate ABS slack, adjust as necessary.
23. Lower vehicle to the ground and tighten the upper control arm hardware to 128 ft-lbs.
24. Torque the lower coilover bolts on the lower control arms to 124 ft-lbs.

REAR INSTALLATION

25. Park the vehicle on clean, flat, and level surface. Block the front wheels for safety.
26. Disconnect the rear track bar from the axle, retain hardware.
27. Raise the rear of the vehicle and support the frame rails with jackstands.
28. Remove the wheels.
29. Support the axle with a hydraulic jack.
30. Remove the OE shocks. Retain the mounting hardware.
31. Remove rear sway bar links from the frame, retain the hardware (Fig. 6). Leave the links attached to the sway bar

FIGURE 6



32. Lower the rear axle and remove the coils, retain the rubber isolators.
33. Slowly lower the axle. It may be necessary to un-clip the hard brake line mounts as well as the wiring harness clips on the rear differential. As you lower the axle ensure that all wiring/hoses have adequate slack and are not overextended. Install the new coil spring with the OE rubber isolator.

Note: If equipped, transfer the coil wrap onto the upper coil windings.

FIGURE 7

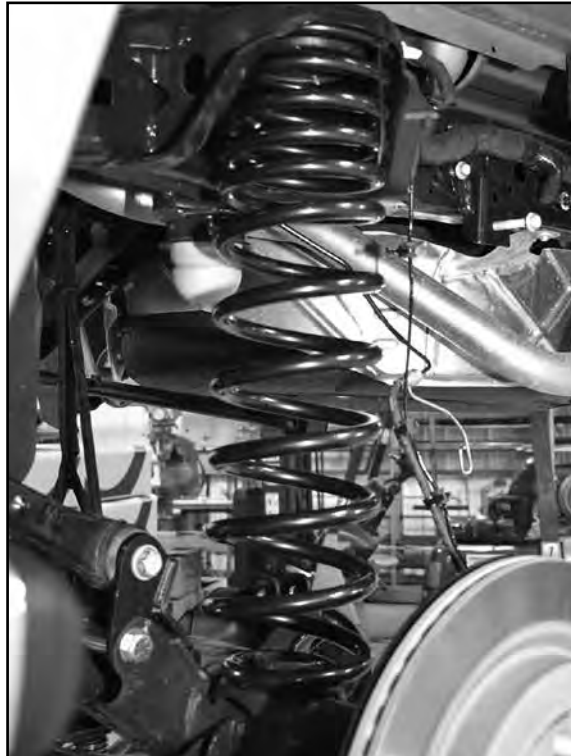

34. Install the new rear shocks. Tighten upper hardware so the bushing starts to swell. Tighten lower shock hardware to 75 ft-lbs.

35. Reinstall the factory sway bar link to the frame mount with the OE hardware. Torque to 41 ft-lbs.
36. Reattach any brake or ABS lines that were disconnected to install the coil springs.
37. Install wheels and lower vehicle to the ground.
38. Torque the wheels to 130 ft-lbs in a crossing pattern.
39. Install the rear track bar into the factory bracket with the OE bolt and nut. Tighten to 127 ft-lbs.

POST INSTALLATION INSTRUCTIONS

40. Check all hardware for proper torque.
41. Check hardware again after 500 miles and at regularly scheduled maintenance intervals.
42. The vehicle will need a complete front end alignment.
43. Adjust headlights.
44. Grease the ball joint at regular service intervals. Replacement ball joint # is 500-1134



WE WANT TO SEE YOUR RIDE!

Grab photos of your BDS-equipped truck in action and send them in for a chance to be featured. Send it in to our Bad Ass Rides customer gallery at bds-suspension.com/bar and post them on the BDS Fan Page on Facebook at facebook.com/BDSSuspensions. Don't forget about your BDS swag! BDS offers t-shirts, hoodies, decals and more available on the BDS website or through your local BDS distributor.

TIME TO HAVE SOME FUN

Thank you for choosing BDS Suspension.

For questions, technical support and warranty issues relating to this BDS Suspension product, please contact your distributor/installer before contacting BDS Suspension directly.

2019-2020 RAM 1500 3" BDS PERFORMANCE SUSPENSION SYSTEM

TORQUE SPECIFICATIONS

COMPONENT	TORQUE (FT-LBS)
Shock Top Hat to Frame	24
Upper Ball Joint	65
Swaybar to Lower Control Arm	88
Upper Control Arm	128
Lower Coilover Bolt	124
Rear Lower Shock	75
Rear Swaybar to Frame	41
Track Bar to OE Bracket	127