

KIFCO®

OPERATOR'S MANUAL

Model

WRT/E-4 & WRT/E-5

Water Reel® Irrigation

Copyright © Jan 2006, Kifco Inc.

Kifco Inc.
707 S Schrader Ave., P.O. Box 290, Havana, IL 62644
Phone 309-543-4425 Fax 309-543-4945
www.kifco.com

P/n 193-0192-1 updated 10/21/10

Introduction

Thank You for purchasing a Kifco® Water-Reel®.

Read this manual carefully to learn how to operate and service your Water-Reel properly. Failure to do so can result in personal injury and/or property damage.

This manual is a permanent part of your Water-Reel and should always be available for reference by the operator. This manual should remain with the Water-Reel when it is sold.

Measurements in this manual are in U.S. units unless otherwise stated.

The machine sides are designated water inlet side and level wind chain side.

The serial number of your Water-Reel should be written in the space provided in the Dealer Checklist section (page 3) of this manual.

If you have a problem or if you do not understand some feature of your Water-Reel, contact your Kifco dealer.

Warranty is provided as part of the Kifco product support. Please see specific warranty statement in this manual.

The warranty excludes:

- ! Alterations or modifications not approved by Kifco Inc. Neither Kifco dealers nor representatives are authorized to make exceptions to warranty policy. Any deviations from standard warranty require written authorization from Kifco Inc. Irrigation tube that is longer, larger in diameter, or made from non-approved materials will void the warranty on the entire machine.
- ! Damage caused by normal wear, accident, lack of reasonable care and maintenance, neglect or abuse.
- ! The replacement cost of normal service items such as filters, gaskets, brake bands, etc., unless these parts are known to be defective.
- ! Transportation, mailing, service call, or diagnosis costs. Labor for repairs is also excluded unless unusual circumstances exist and then only if pre-approved.

Dealer Checklists

Owner's Name _____

Address _____

City _____ State _____ zip _____

Model _____ Serial No. _____ Date Sold _____

Pre-delivery Checklist: Check below before delivery to customer.

- | | |
|--------------------------------------|---------------------------------|
| _____ 1. Guards and shields in place | _____ 6. Sprinkler Nozzles |
| _____ 2. Decals in place and legible | _____ 7. Clutch Disengage |
| _____ 3. Tire pressure | _____ 8. Supply Hose Fittings |
| _____ 4. Lubrication (Page **) | _____ 9. Touch up paint & clean |
| _____ 5. Spool Brake adjustment | |

Delivery Checklist:

Review the operator manual with the user and explain the following:

- _____ 1. Kifco warranty policy and claims procedure
- _____ 2. Safe operation and service
- _____ 3. How to operate your Water-Reel
- _____ 4. Transporting the Water-Reel on roads or highways.
- _____ 5. Speed adjustment and effect on depth of water
- _____ 6. Effect of water pressure on Water-Reel performance
- _____ 7. Winterization and storage procedures
- _____ 8. Give the customer this manual and encourage the customer to read and study the information in the manual.

Date Delivered _____

Name of Dealer _____

Dealer Phone Number _____

Table of Contents

Introduction	1
Dealer Checklists	2
Safety	4
Controls	8-9
Handling the Polyethylene Tube	10
Maintenance and Service	11
Water-Reel Start-up & Operation	12
Performance Guide	18
Adjustments	
Level-wind Timing	19
Sprinkler Options	20
Brake Adjustment	21
Engine Drive travel speed	22
Maintenance	
Polyethylene Tube Repair	23
Filters	24
Valve Plumbing	25
Winterization and Storage	26
Assembly	27
Specifications	28
Booster Pump	29-30
Optional Equipment	31
Warranty	32

Parts Book Available at www.kifco.com

Safety

Owners Responsibilities

The owner is responsible for the safe operation of this product.

It is the owner's responsibility to:

1. Read and understand these instructions.
2. Operate the machine according to prescribed limitations.
3. Properly train others who may be permitted to operate the machine.
4. Heed rules of safety, including but not limited to those in these instructions.
5. Exercise good judgment relating to safe operation and safe conduct by operators and spectators whether invited or not.
6. Always bring the safety decals and placards on the machine to the attention of operators and spectators.
7. ***Keep all shields and guards in place!***

Read and Heed the Special Messages!

This safety alert symbol is used to indicate messages related to safety. When you see this safety symbol, obey the safety message to avoid personal injury, property damage or both.



A "**Caution**" message in this manual or on a machine placard means that you could be injured and/or equipment or property may be damaged if you do not follow instructions.

A "**Warning**" message in this manual or on a machine placard means that a hazard exists that could result in severe personal injury or death.

A "**Danger**" message in this manual or on a machine placard means that a hazard exists that will result in severe personal injury or death.

Location of Safety Messages:

These safety messages are placed for the operator's safety.
You **MUST** read and follow these precautions to prevent injury.

1. **CAUTION**
BLEED OFF PRESSURE SLOWLY BEFORE
REMOVING SUPPLY HOSE

2. **CAUTION**
BEFORE PULLING CART OUT, TURN OFF
WATER AND DISENGAGE DRIVE

3. **WARNING**
REPLACE SHIELD:
IF YOU CAN READ
THIS A SHIELD HAS
BEEN REMOVED

4. **WARNING**
10
MPH
NOT DESIGNED FOR
HIGHWAY USE
MAXIMUM SPEED 10 MPH

5. **WARNING**
DO NOT DISENGAGE
DRIVE WHILE
IN OPERATION!

6. **WARNING**
STAND CLEAR OF SPRINKLER

7. **WARNING**

DO NOT OPERATE THIS MACHINE UNTIL YOU HAVE READ AND UNDERSTAND THE OPERATORS MANUAL, IF YOU DO NOT HAVE A COPY OF THE OPERATORS MANUAL, CONTACT YOUR DEALER OR OUR FACTORY IMMEDIATELY:

DO NOT OPERATE THIS MACHINE UNLESS ALL SAFETY SHIELDS ARE SECURELY IN PLACE.
DO NOT CLEAN, LUBRICATE, ADJUST OR REPAIR THIS MACHINE WHILE IN OPERATION.
DO NOT RIDE OR CLIMB ON THIS MACHINE AT ANY TIME.
DO NOT PLACE HANDS BEHIND SHIELDS WHILE THE MACHINE IS IN OPERATION.
DO NOT ALLOW CHILDREN OR OTHERS NEAR THE SPRINKLER, CART OR MACHINE DURING OPERATION.

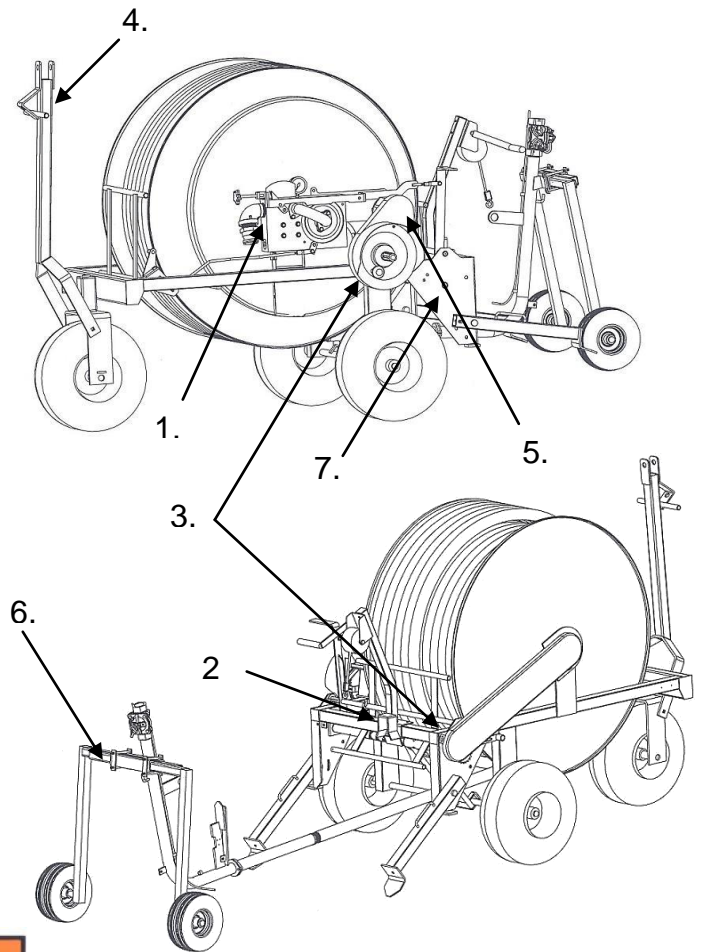

Safety

Learn To Be A Safe Operator

Read This Manual

Know the controls on the Water-Reel and also how to stop the water supply! Do not allow children to operate the Water-Reel.

Do not allow anyone to operate the Water-Reel with out proper instruction.



Protect Children

Keep children away when you operate the Water-Reel.

Do not allow children to operate the tractor that is positioning the Water-Reel.

Never allow children to climb or ride on the machine at any time.

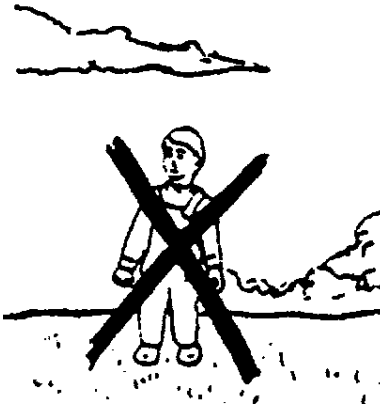

Use Caution Around Pressurized Lines

For your own protection, always take care when working with or around pressurized equipment. Shut off the pump before working with any components. Including the pump, supply lines, machine or related equipment.

Be sure pressure is relieved from any supply line before it is disconnected.



When the automatic sprinkler shut-off is used, pressurized water may be trapped in the system tube.

Stay Away From Operating Sprinklers

Stay away and keep others away from the sprinkler head during operation. Pressurized water from a sprinkler can inflict serious injury to bystanders.

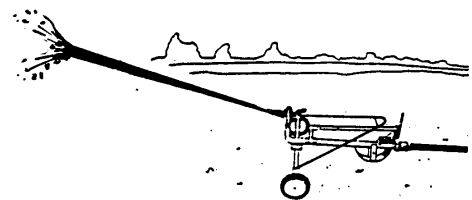

Safety

Use Caution When Towing

Your Water-Reel is not intended for highway towing.

Towing Speed:

10 MPH maximum on smooth surfaces.
3 MPH maximum on rough surfaces.

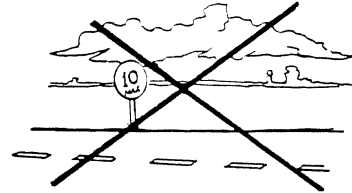

Never tow the Water-Reel in excess of 10 MPH.

Keep Hands and Clothing Away

Do not under any circumstances reach into the Water-Reel while it is in operation.

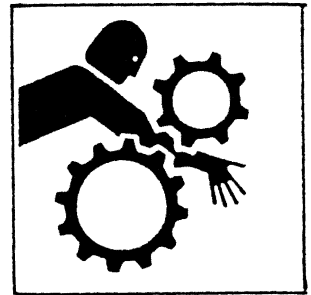

Keep All Guards and Shields in Place

Never operate this machine with safety guards removed!

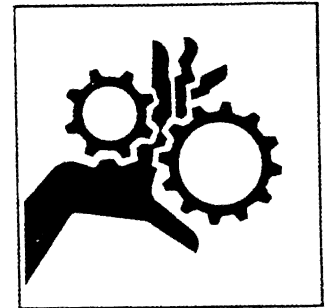

Never Service or Make Adjustments While the Water-Reel is Pressurized

Shut the water off at the source before attempting to do any service, maintenance of adjustments.

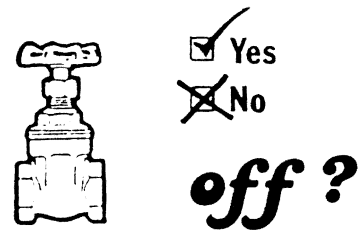

Stay Away From Power Lines

Avoid letting irrigation water contact power lines.

Be careful not to contact power lines with irrigation pipe or mechanical equipment.



Controls Turbine Drive

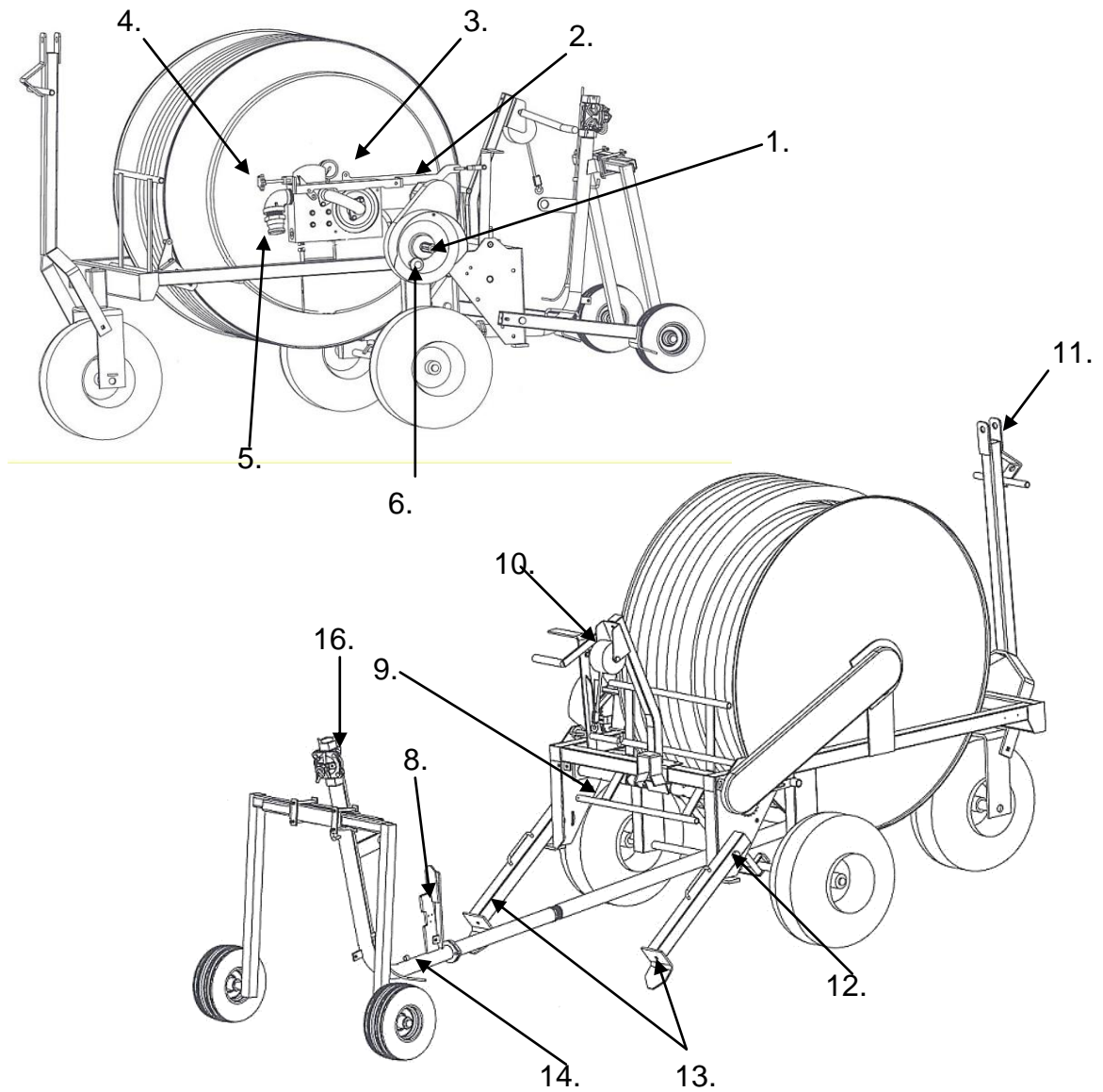

- 1. PTO Adapter
- 2. Shut-off Hold Out
- 3. Gauge (160lb)
- 4. Travel speed
- 5. Entry Fitting
- 6. Clutch Disengage Knob

- 8. Actuator Valve
- 9. Auto Shut Off Bar
- 10. Transport Boom
- 11. Towing Hitch
- 12. Release Pin
- 13. Stabilizer Leg
- 14. Gun Cart
- 15. Rewind Tool (not shown)
- 16. Pressure Relief Valve
and Sprinkler Control Selector Valve

Engine Drive Controls

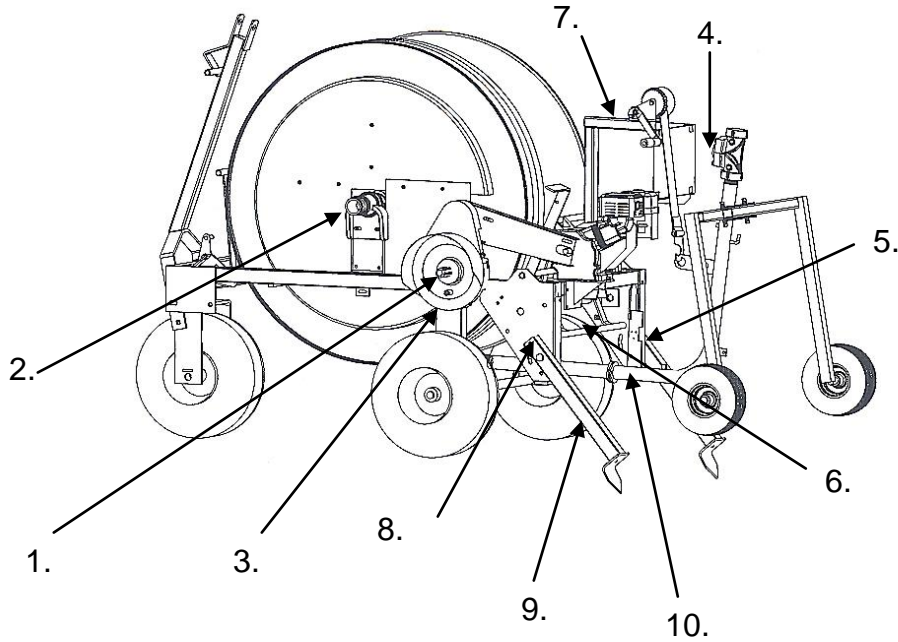

- | | |
|--|-----------------------------|
| 1. PTO Adapter | 7. Transport Boom |
| 2. Entry Fitting | 8. Release Pin |
| 3. Clutch Disengage Knob | 9. Stabilizer Leg |
| 4. Sprinkler Control Selector Valve
and Pressure Relief Valve | 10. Gun Cart |
| 5. Actuator Valve | 11. Rewind Tool (not shown) |
| 6. Auto Shut Off Bar | |

Handling The Polyethylene Tube

The polyethylene irrigation tube is a durable product that will operate reliably for many years if handled properly and given a reasonable amount of care.

Unlike rubber hose or hose with a woven jacket (lay flat hose), polyethylene is a semi-rigid product that retains its shape when it is not pressurized. This characteristic makes it feasible to pump water through it while it is rolled up on a reel.

A few simple precautions need to be observed to prevent damaging the tube when operating your Water-Reel.

When starting a new water-reel for the first time, it is important that the tube be pulled nearly all the way out in order to tighten the new tube on the spool.

1. ***Never transport the Water-Reel with the drive disengaged! The irrigation tube will become loose and tangled.*** Do not attempt to operate the Water-Reel if there are any coils of tube that are loose or misplaced. If loose coils of tube are noticed after pulling the tube out, they must be tightened by rotating the spool by hand. If this is not possible, then pull all of the tube out before attempting to rewind the tube.
2. Never try to relocate the Water-Reel if the tube is not fully rewound onto the machine.
3. Never pull the tube off the machine other than by pulling on the sprinkler cart (straight out from the machine).
4. Never run over the tube with any kind of vehicle and avoid pinching or pulling the tube around objects. Make it a point to never bend the tube sharper than 25 times the diameter of the tube.
5. Be careful when operating other equipment near the tube so that it doesn't get gouged or punctured.

Remember, polyethylene tube is semi-rigid and subject to being kinked. These foregoing precautions will reduce the possibility of kinking or damaging your tube. Throughout the irrigation industry the words 'tube' and 'hose' are used interchangeably in connection with hard hose traveling machines.

Maintenance and Service

Maintenance Procedures: Perform inception and any maintenance procedure after 100 hours of use. Your Water-Reel machine is equipped with Delrin® spool bearings, that do not need lubrication, but should be inspected periodically for any wear problems.

Tire Pressure: Inflate tires to the pressure imprinted on each tire.

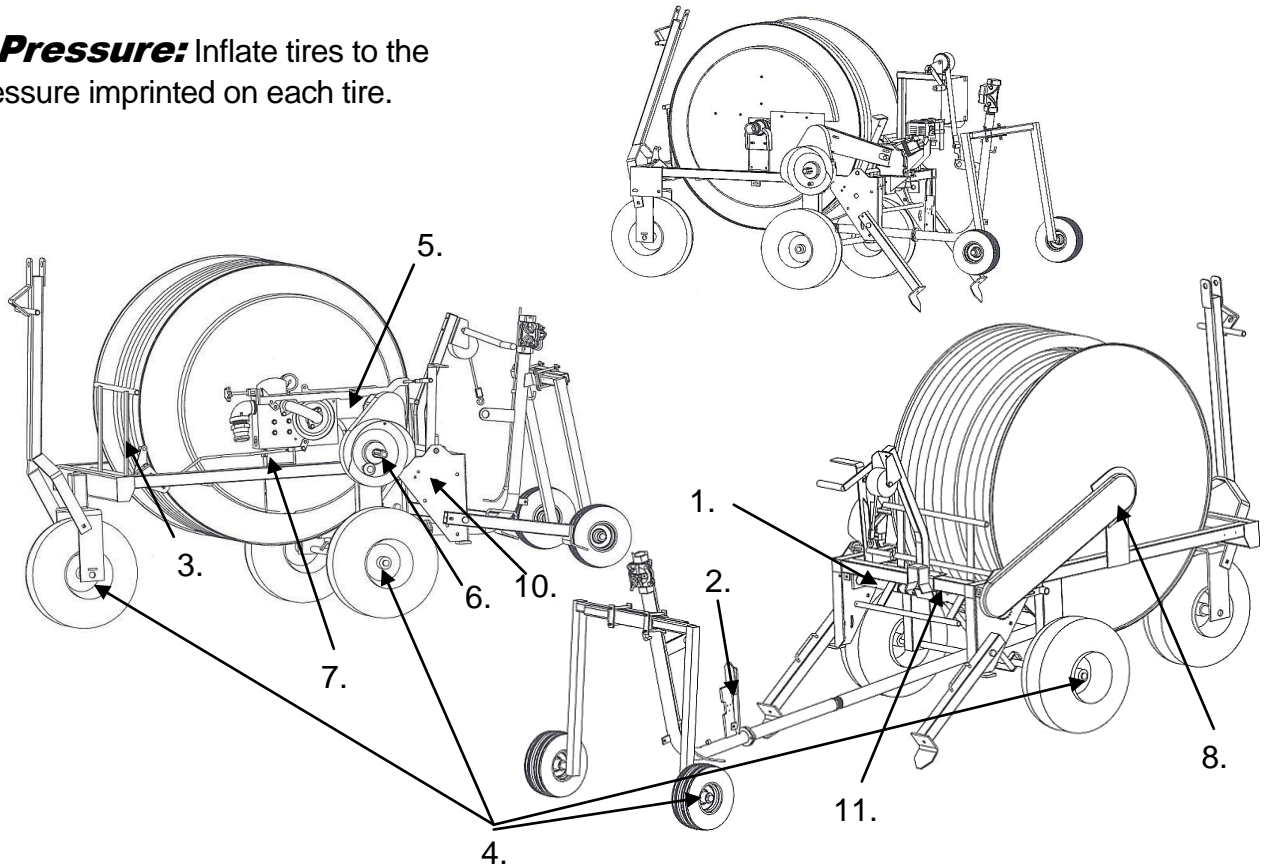

1. Level wind screw- check for excessive wear
2. Valve Actuator- lubricate spool with liquid soap
3. Tube rider- oil pivot points if necessary
4. Wheels - grease at zerk periodically
5. Drive belt, check periodically
6. Clutch drive sprocket- grease periodically
7. Turbine filter- drain
8. Level wind drive chain- oil periodically
9. Tube rewind tool (not shown)
10. Levelwind sleeve bearing – grease at zerk periodically
11. Levelwind follower – grease at zerk periodically

Water-Reel Start-Up & Operation

The successes of the Water-Reel irrigation system depends a great deal on the operator's understanding of the proper pull out and start up procedure. **Do not attempt to operate this Water-Reel until you read and understand the preceding section titled "Handling the Polyethylene Tube"!**

The following steps are important.

1. Pull the Water-Reel into position with the sprinkler cart towards the run to be irrigated. Be especially careful to have the machine square and in good alignment with the irrigation path. It is allowable for the tube not to be pulled out in a straight line, however, it is important that **the first 25% of the tube be pulled straight away from the machine.** Failure to observe this limitation places excessive side load on the level wind mechanism and may result in equipment failure or tube damage.
2. Fold down the stabilizer legs and confirm they have made good ground contact. Make sure both legs swing freely at their hinges. **Never** attempt to operate the Water-Reel with only one leg down.

When the Water-Reel begins to operate with the tube pulled out, the machine may raise up onto the stabilizer legs. The machine is then resting on the front wheel and the stabilizer legs with the two main wheels off the ground. This is normal. Do not attempt to interfere with this action. The Water-Reel has been designed to maximize its capability to anchor itself. Also, front wheel must be straight. **Do not turn the front wheel crossways.**

3. Disengage the clutch. To disengage, pull on dog knob and rotate 90° to locked out position.

Water-Reel Start-Up & Operation

4. Check spool brake for proper tension. There should be noticeable resistance to unrolling. The purpose of the spool brake is to prevent coasting of the spool during tube pull out. **Coasting of the spool is the most frequent cause of malfunction!** This problem is most common when the Water-Reel is frequently used in short runs and the entire tube is seldom pulled all the way out. When the spool coasts, it will appear that the level-wind mechanism is out of time with the incoming tube, **make no attempt to re-time the machine until it is determined that the tube is not loose.** If the tube does become loose the only way to correct the problem is to pull the tube all the way out and allow the machine to operate a full-length run. See the "adjustments" section of this manual for adjusting the spool brake.
5. Attach the water supply line to the machine to confirm that all lines reach and the Water-Reel is set in the proper place. **Do not turn on the water.**
6. Lower the sprinkler cart from its transport position. Determine if the automatic sprinkler shut off is to be used and set the desired sprinkler arc. See Following Diagrams.

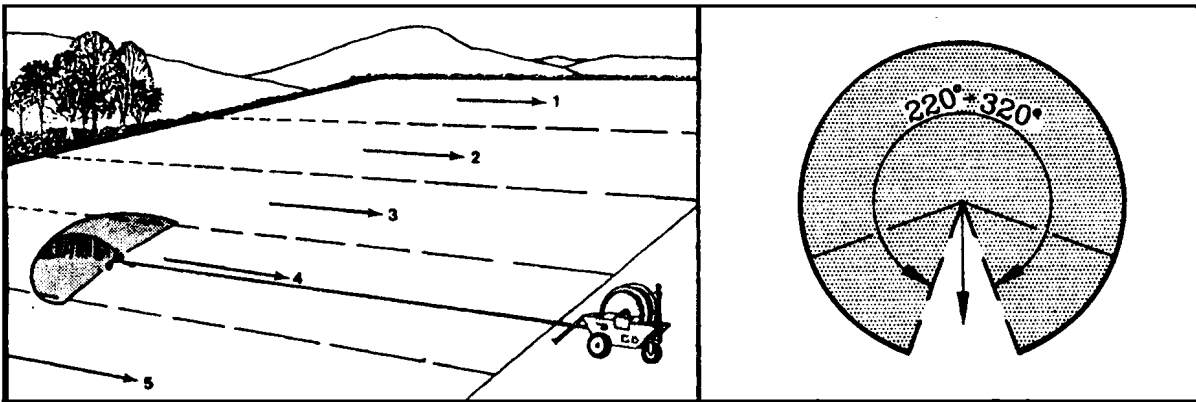

Start-Up & Operation

7. Pull the sprinkler cart out the desired distance. Pull the tube out slowly 3 m.p.h. and avoid sudden stops or any thing that will make the spool more likely to coast.

Warning!
Stand clear of the machine and the guncart while the tube is being pulled out.

Note: When the tube is pulled out to follow a contour or to avoid an obstacle, the extent that it is pulled in a curve should be very gradual. Under no circumstances should the tube curve more than 90 degrees in its entire length. How well the tube will follow its laid out path back to the machine will depend mostly on the surface of the ground. For example, if there are contours or furrows to follow, the tube may track back very well. If the soil or vegetation is slick and no rows or furrows exist, the tube may cut across the laid out path and be recoiled back on the machine in the shortest distance. (A straight line)

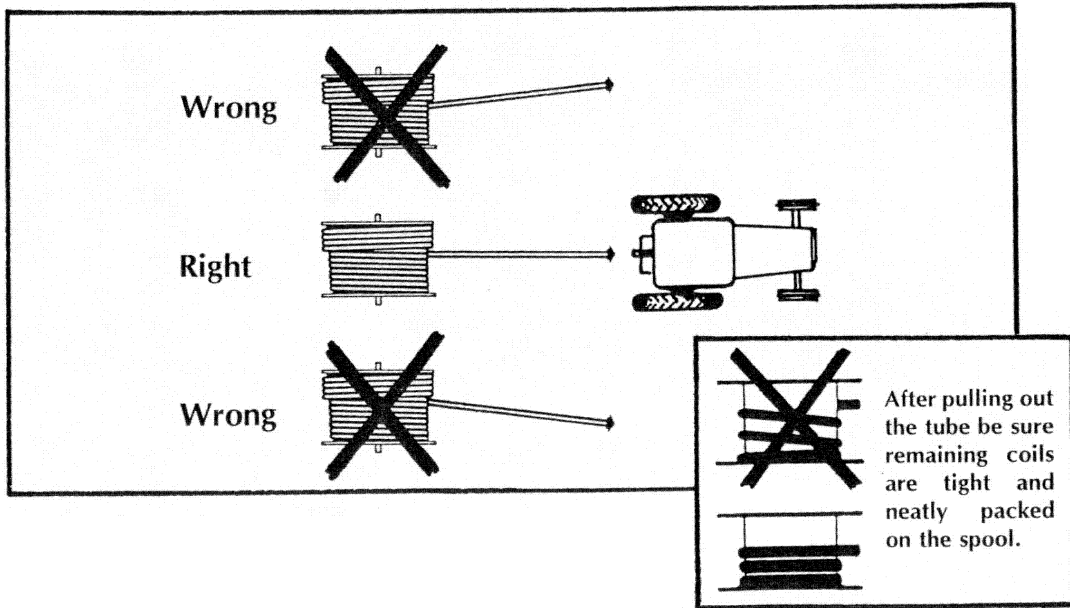

Start-Up & Operation

- Determine if the automatic water shut-off is to be used and set the valve accordingly. To reset the Sprinkler Control Valve, push the actuator knob into the forward most position. The sprinkler flow selector valve will only operate automatically if the actuator valve has been reset.

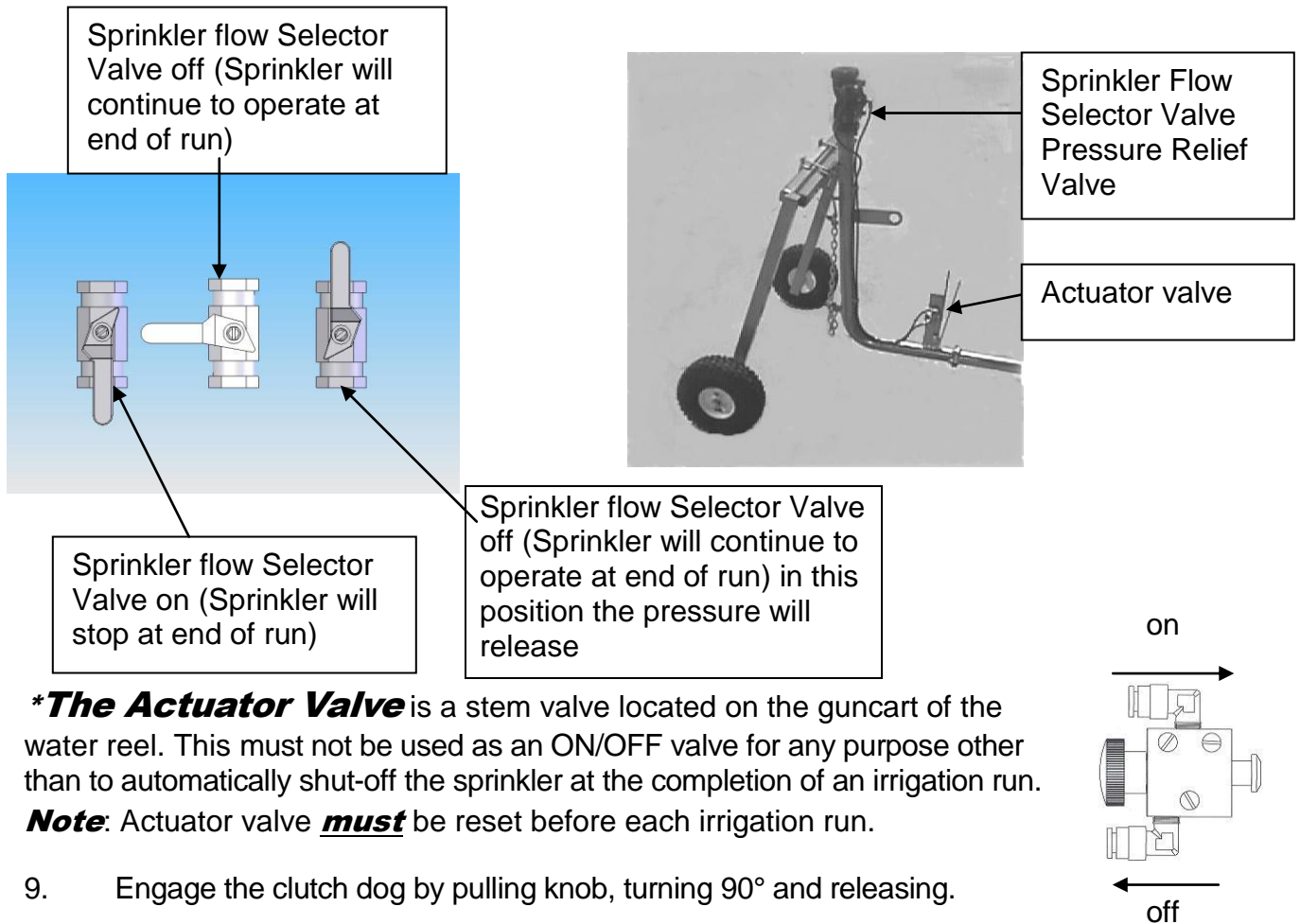

***The Actuator Valve** is a stem valve located on the guncart of the water reel. This must not be used as an ON/OFF valve for any purpose other than to automatically shut-off the sprinkler at the completion of an irrigation run.

Note: Actuator valve **must** be reset before each irrigation run.

- Engage the clutch dog by pulling knob, turning 90° and releasing.
- Turn on the water supply. Confirm the sprinkler is operating as expected and in the desired arc.
- After all air is purged from the system and the sprinkler is operating smoothly, raise the shut off latch, the machine will then begin to rewind. Set the Travel Speed Control to the desired retraction speed. **Note:** As tube tightens, be sure coils are lying side by side (no gaps).

The Travel Speed Control Screw, located on the turbine block, controls the butterfly that regulates the amount of water flowing through the turbine motor.

Start-Up & Operation

11. Observe water pressure, travel speed, and sprinkler performance to confirm desired performance. See performance guide supplied with the machine.

Turbine Drive Only.

On initial start up, adjust lock nut (#2) on travel control screw. To adjust, turn speed control knob out until a noticeable pressure change has occurred (approximately 10 PSI). Once this is reached, screw lock nut to face of plate (nut is not used to lock screw, only to prevent over speed).

1. Knurled nut, used to lock travel control screw.
2. Lock nut, used to prevent excessive pressure loss through turbine.
3. Speed Control Knob

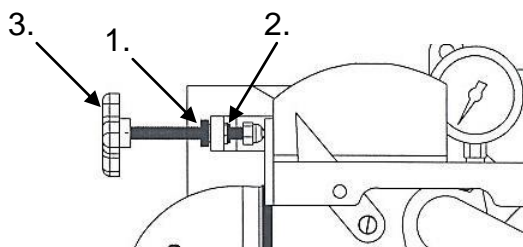

13. When the sprinkler cart completes the irrigation run and has contacted the shut-off bar, the retraction of the hose will stop. If the sprinkler control valve was set for automatic water shut-off, the water flow will also be stopped.

Important

When using the automatic water shut-off feature, be sure the water can be shut-off automatically without damaging the water supply or the Water-Reel! Stopping the flow of water can damage a pump or water lines and excessive pressure can be created. A qualified person should confirm if you could safely utilize the automatic water shut-off.

Note: Some municipalities prohibit the use of water mains intended for fire protection and there may also be requirements for back-flow prevention. Investigate and obey all local regulations regarding the use of water.

14. With the irrigation run completed, turn off water supply, open the pressure relief valve. Lift the sprinkler cart and stabilizer legs into transport position, and disconnect the water supply. The Water-Reel is now ready to be moved and set up in a new location. **Note: On completion of first run only!** Adjust the transport arm so it is directly above the sprinkler cart body.

Anti-Reverse Pawl:

The anti-reverse pawl engages the teeth of the clutch sprocket, and prevents the tube from becoming loose on the spool due to spool backlash, at the end of the run or during machine transport. **NOTE: Clutch must be engaged to prevent backlash.**

Tube Rider:

The tube rider applies pressure to the tube preventing the tube from becoming loose as the sprinkler cart approaches the machine and sprinkler thrust tends to push the cart forward.

Start-Up & Operation

Depth Of Water Applied:

The depth of water applied by the Water-Reel is regulated by the speed the sprinkler is moving over the ground. It is also affected by the amount of water being discharged by the sprinkler head.

The sprinkler nozzle size and the water pressure determine the amount of discharged water. These two factors are determined by the available water and the capability of the water pump at the water supply. The selection of the sprinkler nozzle needs to be made based on the water supply and pump performance.

Travel Speed Settings- Using the Performance Guide:

Inlet PSI is always read @ the Water Reel and while sprinkler valve is open and water is flowing from sprinkler.

MODEL T200 X 580' KOMET TWIN MAX Area covered may vary depending on wind conditions, field dimentions, & use of different sprinklers. Specifications are subject to change without notice.	Nozzle size	SPRINKLER			AREA (Ft)			INLET PSI	INCHES DEPTH OF APPLICATION								
		PSI	GPM	DIA	WIDE	X	LONG		TRAVEL SPEED - FEET PER HOUR								
									0.3	0.4	0.6	0.8	1	1.2	1.4	1.6	
	0.51"	40	47	179	143	X	652	62	92	69	46	35	28	23	20		
	0.51"	50	53	191	153	X	656	75	97	73	49	37	29	24	21		
	0.55"	40	55	186	149	X	654	66		78	52	39	31	26	22	19	
	0.55"	50	62	197	158	X	659	80		83	55	41	33	28	24	21	
	0.63"	40	72	200	160	X	660	76		95	63	47	38	32	27	24	
	0.63"	50	80	215	172	X	666	92		98	65	49	39	33	28	24	
	0.67"	40	81	208	166	X	663	83		103	68	51	41	34	29	26	
	0.67"	50	91	224	179	X	670	101		107	71	53	43	36	31	27	

**WARNING! TO AVOID EXCESSIVE PRESSURE LOSSES, NEVER OPERATE THIS MACHINE AT SPEEDS HIGHER THAN INDICATED!
USE THE HIGH SPEED BELT PULLEY FOR SPEEDS OVER 50 FEET PER HOUR**

Start-Up & Operation

After the desired depth of water has been determined and the proper nozzle has been installed, follow the steps in the following example to set the speed: (Assume: 0.55" nozzle, 80 PSI inlet pressure, and a desired depth of water of 1 inch.)

1. Find the proper section in the Performance Guide for the 0.55" nozzle. (1)
2. Locate the 80 PSI inlet pressure. (2)
3. Find depth of application 1.00 inch (3)
4. Locate 33 feet per hour. (4)
5. You can see that the water pressure on the sprinkler nozzle is 50 PSI. The flow in gallons per minute being discharged through the sprinkler is 62 and the wetted diameter is 197 feet. (5)
6. The effective irrigated width is 158 feet and the maximum effective irrigated length is 659 feet (6)
7. Hours required for a complete run is 17.6 hours. Approximate time can be figured by dividing the tube length by the feet per hour.

There are several possible settings,

Nozzle Size	GPM	Irrigated Area	PSI	Feet Per Hour	Hours for Full Run
0.51"	47	143' x 652'	62	28	20.5
0.55"	62	168' x 659'	80	33	17.5
0.67"	81	166 x 663'	83	41	14.2

Note: The PSI is the pressure reading while the machine is running and the sprinkler is operating. If the pressure drops while running, use the chart to determine the performance at the new inlet pressure. If the pressure drops below the lowest inlet pressure shown, consider using a smaller size nozzle.

Adjustments

Level-Wind Timing:

Proper timing of the level-wind mechanism is essential to the successful operation of the Water-Reel. Improper level-wind timing will result in mis-wrapped tube. Travel will be interrupted because the auto shutoff bar will stop the water motor in order to prevent damage to the irrigation tube. **Do not continue to operate if the tube is not winding properly!**

Important! Be positive that the timing is really at fault before attempting to change the timing. Your Water-Reel was shipped from the factory with the tubing wound on it. The level-wind timing was set at the factory prior to installing the tube. If there has been no disassembly of the level-wind mechanism, or the tubing removed & reinstalled, it is very unlikely that the timing is wrong. If the tube is loose on the spool the level-wind system will appear to be out of time. **(See item #4 in the Water-Reel Start-up & operation section of this manual and also the brake adjustment section).**

To retime the level-wind, these steps **must** be followed:

1. Pull all the irrigation tube out from the Water-Reel. The elbow to which the tube is fastened must be on 45° with the elbow outlet pointed toward the sprinkler cart. (See Figure 1). Be especially careful not to pull the tube off the elbow. You may wish to stop slightly before the elbow is exactly on 45° location and turn the spool the last few degrees by hand.
2. Observe the position of the tube follower on the horizontal level-wind screw. The tube follower must be in its most extreme position (all the way to the end of the level-wind screw thread) and on the same side of the Water-Reel as the spool elbow. (See Figure 2). Align the timing mark with the timing mark decal arrow.

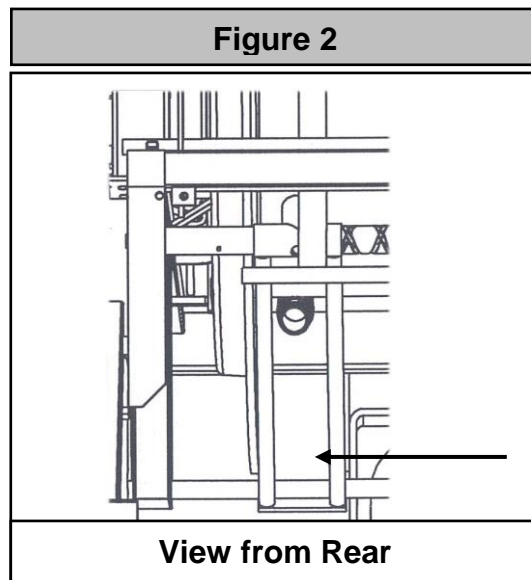
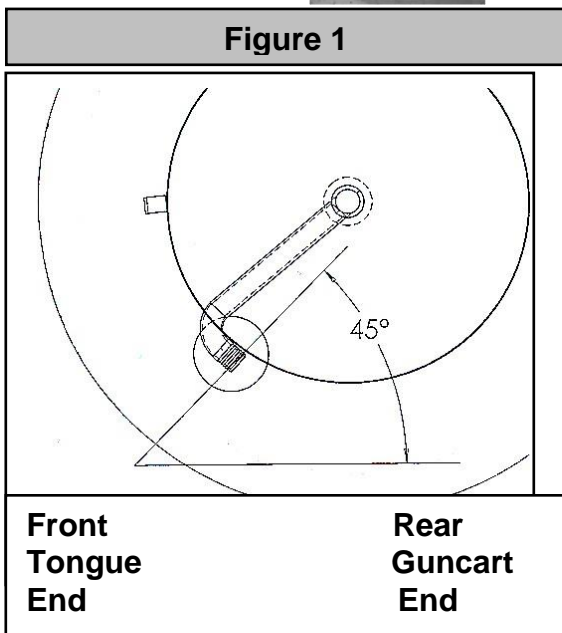
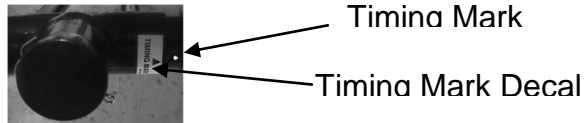

Adjustments

3. To change the timing, remove the shield and level-wind drive chain from the right hand side of the Water-Reel. Rotate the level-wind input sprocket until the tube follower is positioned as described in step #2. Reinstall the level-wind drive chain and shield.

The level-wind will now be in proper timing.

Important

Never attempt to retime the Water-Reel without first pulling all the tube out. Changing the timing with some of the tube still on the spool may result in damage to the irrigation tube and/or the Water-Reel.

Sprinkler Options and Adjustment

1) Nozzle

2) Part Circle Pin

3) Part Circle Stops

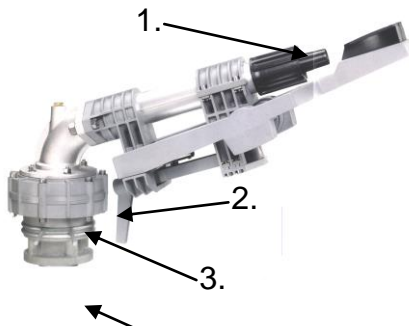

Komet Twin Max

Part circle stops can be rotated to provide any desired arc of operation. No tools are required to change the arc. **Do not** attempt to remove the spring clips from the base of the sprinkler.

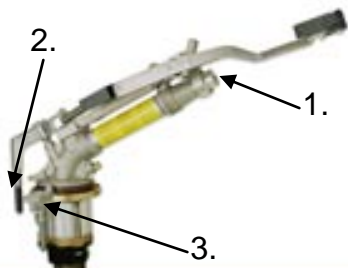

Nelson SR-75

Part circle stops can be rotated to provide any desired arc of operation. To adjust the stop slacken the lever bolt, move the stop and re-tighten

Adjustments

Adjusting Spool Brake

The purpose of the spool brake is to prevent coasting of the spool when the tube is being pulled out. This function is important in order to keep the tube from becoming loose on the spool.

The brake band must be in good working order and maintained at the proper tension. The brake should offer substantial resistance to turning the spool by hand

To adjust the spool brake, turn the tensioning nut, behind the clutch sprocket, clockwise. This will increase the drag on the spool during tube pull out. The spring should be approximately 4 inches in length when adjusted.

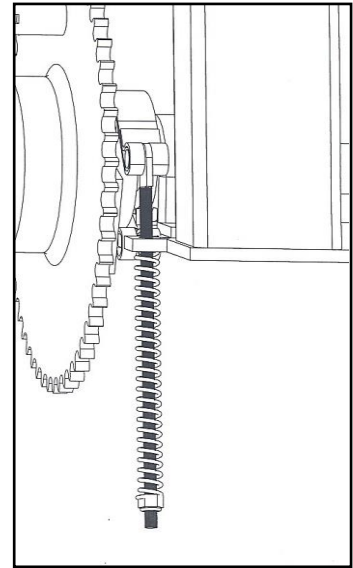

Note: When the tube becomes loose on the spool, it may appear that the levelwind is not in time with the incoming tube. This occurs because the spool is coasting inside the coils of tube. The level-wind mechanism is moving but no tube is coming out.

This problem is more noticeable if the Water-Reel is being used on short runs where the entire tube is seldom pulled all the way out.

Turbine Speed Adjustment

The turbine speed is controlled by the position of the butterfly valve. As the butterfly opens, water can by pass the turbine. The speed can be adjusted by turning the travel speed control knob.

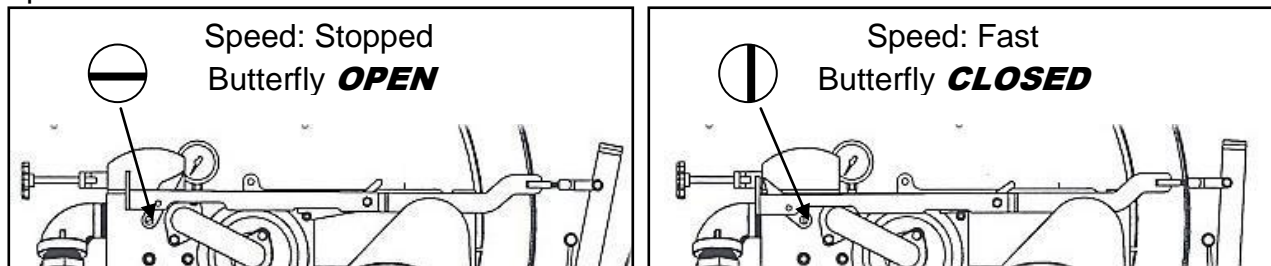

To adjust, refer to paragraph # 2 of step # 11 page 15.

1. To manually stop tube rewind pull handle on shut off bar back so the shut off latch drops into position.

Note: Latch will lock the bar in the off OFF position; latch must be released to restart the turbine.

Adjustments

Tube Rider Bar Adjustment

Adjust the tube rider bar (using the adjustment bolt on the left side of machine) so the distance between the bar and the spool core is 5 inches then tighten locknut.

Engine Drive Only

Travel (rewind) speed adjustment

The travel speed of an engine drive machine is determined by the engine R.P.M. which is adjusted by the engine throttle.

On units with standard slow speed drive train configuration 3600 engine R.P.M. produces a *average rewind top speed of approximately 15 inches per minute.(75 f.p.h.)

Adjust engine speed to achieve desired rewind speed, Minimum engine recommended speed of 1800 R.P.M. produces average rewind speed of approximately 7 inches per minute.(37.5 f.p.h.)

On units with standard high speed drive train configuration, 3600 engine R.P.M. produces an *average rewind top speed of approximately 120 inches per minute, with the average low rewind speed being 60 inches per minute.

* NOTE- Average rewind speed is the rate of tube re-wind at mid point of the run when the spool is approximately half full.

Speeds other than standard can be achieved, consult factory for recommendation.

Recommended engine speed for sustained operation is 1800 to 3600 R.P.M.

Repair and Maintenance

Warning! Installing fittings or repairing polyethylene tube used on your Water-Reel is hazardous! The tube has a memory from being coiled on a reel and will try to coil back up if the tube is loosened from one end or cut in two. The condition poses a serious hazard to person and/or property. The tube must be restrained any time there is a loose end!



Polyethylene Tube Repair

Screw-in menders are an excellent alternative to Butt Fusion Welding for the repair of Polyethylene tube. The compact design allows a mender to be wound onto the spool without damaging itself or the adjacent coils of tube. They can be installed in the field and the tube can be put into service immediately after the repair is made. The menders are designed to be fitted at ambient temperature. **Never** try to apply heat to assist installation. Menders must be installed straight and concentric with the tube to prevent premature failure.

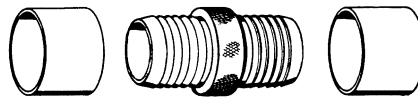

Installation Instructions



Cut the tube on either side of the damaged area. Make good straight cuts. Use a block of wood or soft hammer to tap the collar fully on to the end of the tube.



Chamfer the tube internally with a knife or coarse file so that the end of the screw-in mender will enter the tube.



Important: Please note the mender threads are different on each end. One is left hand and one is right hand. Screw the mender about 2/3rds into the end of the tube using a wrench on the center knurled shoulder. Then unscrew it. Repeat the procedure for the other end. Watch for the left hand thread.



Now start the mender in both ends simultaneously. As it screws in, it will draw both ends of the tube to the center. This time, screw it all the way to the shoulder. The tube should now be ready to go immediately back into service.

Repair and Maintenance

Filter

Your Water-Reel is equipped with a filter to protect the water motor from dirt and debris, which may be present in the irrigation water. The filter protects **only** the water motor. The water flowing out of the sprinkler is not filtered.

To clean the filter; turn OFF water supply, remove the filter cap on the bottom of the turbine manifold, and pull out filter with fingertip. Clean and inspect the filter than reinstall.

Never attempt to remove the filter while the machine is pressurized. Always turn off the water supply and relieve pressure before starting any form of maintenance.

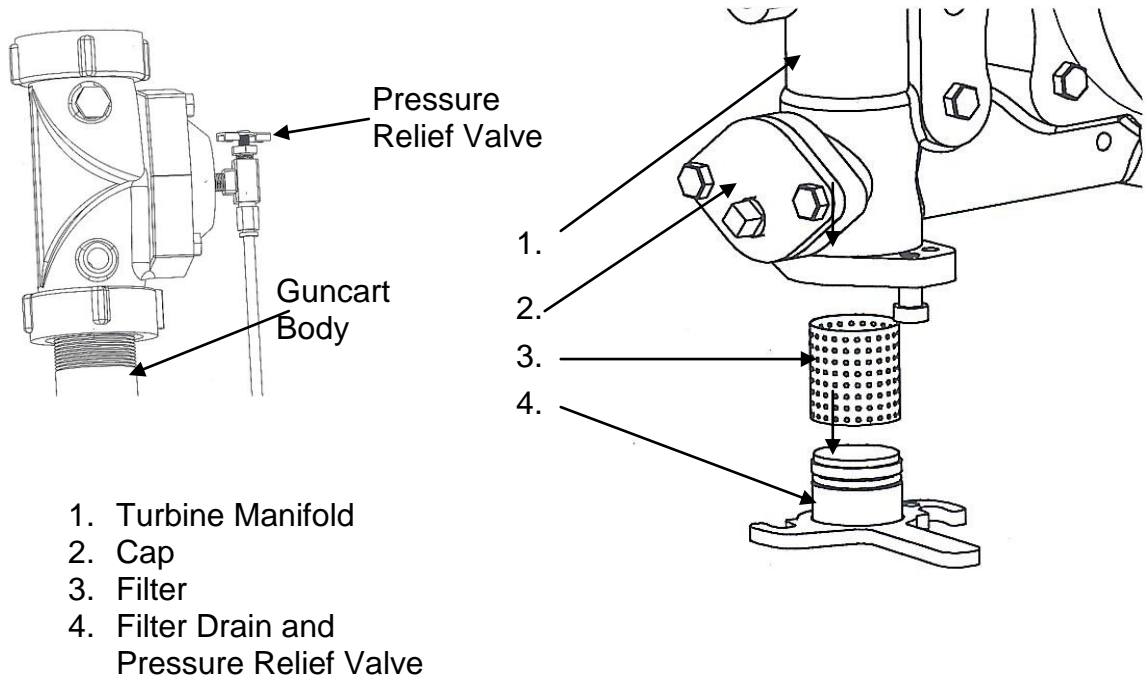

The filter should be cleaned at least once each season, even when operating with clean water. When pumping from ponds or streams, the filter must be cleaned more frequently. In very dirty water conditions it may be necessary to clean the filter each time the Water-Reel is used

Repair and Maintenance

Valve Plumbing

The Actuator Valve signals the sprinkler control valve by supplying pressurized water to the diaphragm of the water sprinkler control valve at the completion of the irrigation run.

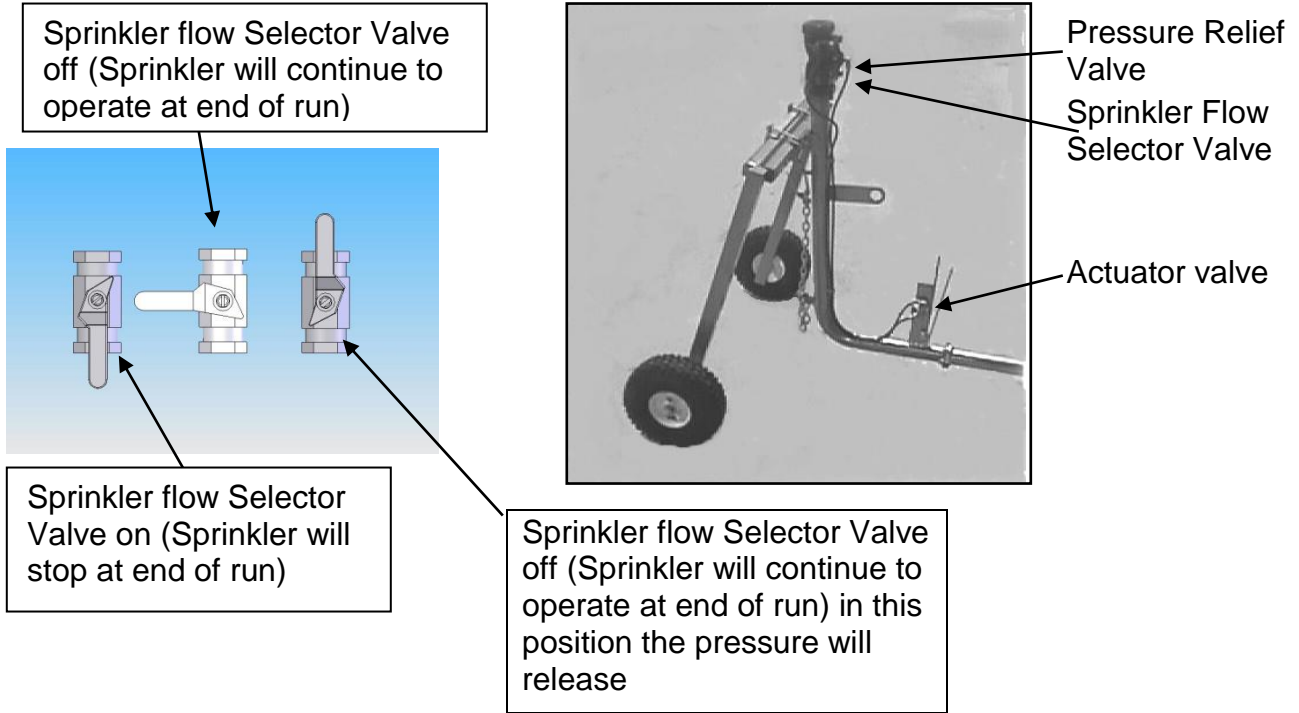

Note: In applications where the water has a high mineral content, buildup of minerals in the actuator valve can cause the valve to be difficult to shift.

To free the valve, apply liquid detergent to the exposed ends of the valve stem, or in the top fitting (after removing tube) and work the stem back and forth by hand.

Note: To remove the small lines from their fittings, depress the ring at the top of the fitting and pull tube out. To reinstall the tubing insert into fitting and push firmly until it seats.



To disconnect, push in release collar with thumb and index finger, pull the tube free.



To connect, push tubing in until it Bottoms on the tube stop.

Winterizing and Storage

For winter and/or off 'season' storage do the following:

Winterizing

1. Open the drain valve on the gun cart and remove the filter cap on the base of the turbine manifold.
2. Be certain the water inlet to the Water-Reel is open and the water supply hose removed. Pull 3 or 4 coils of tube off the hose spool. Rewind the coils of tube by hand. ***Freezing will not damage the type of Polyethylene tube used on your Water-Reel.*** Even though the tube does not need to be drained you must take care to drain all metal parts.
3. Remove plug, and open petcocks to drain gun cart body and sprinkler control valve
4. If the machine is equipped with a booster pump, the pump must also be drained.

Storage

1. Lubricate all points in the lubrication chart to prevent rust and corrosion from forming.
2. Check and Clean filter.
3. Store the Water-Reel away from the direct rays of the sun.
4. Make sure all openings such as the water inlet are plugged so rodents and insects cannot bring foreign material into the Water-Reel.
5. When taking the Water-Reel out of storage, be sure there are no rodent or insect nests that may plug filters, valves or sprinkler.
6. If a Booster Pump is installed it is recommended to service the engine in preparation for the next season.

Assembly

Water-Reels are shipped with all primary assembly complete. The only items to assemble at the destination are:

1. Pull out hose end a few feet, and install guncart.
2. Sprinkler installation on the cart.
3. Installation of the proper sprinkler nozzle.
4. Final adjustment of the transport arm should be made upon completion of the first irrigation run.

The transport arm should be located directly above the sprinkler cart body when the sprinkler cart is completely drawn up to the shut-off bar. This exact location is not possible before the Water-Reel has been operated because the irrigation hose may be loose on new units, particularly if they have been shipped a long distance. (See "Handling the Polyethylene Tube" section).

Check tire pressures before attempting to tow the Water Reel

Floation tires 15-20 PSI

Tires 14" or less 20-30 PSI

Tires above 14" 40-50 PSI

Check tire wall for actual pressure rating.

Specifications

Dimensions, Weights, Etc.

Cart suspended from the transport attachment.

Model	WRT-4	WRT-4		WRT-5	WRT-5
PE Tube ID/LENGHT	1.80/380	2.00/320		2.00/580	2.10/320
PE Tube Length	380	320		580	320
Dry Weight (lbs)	890	900		1290	1220
Weight w/water (lbs)	1260	1340		2000	1820
Dimensions (ft-in)					
Machine Length	5-4	5-4		7-6	7-6
Length w/cart*	6-0	6-0		10-6	10-6
Width	4-3	4-3		5-0	5-0
Height	4-9	4-9		5-8	5-8

Machine/Sprinkler Performance

Information is also available from your dealer or Kifco Inc.

Booster Pump Operating Instructions

The Booster Pumps fitted to Kifco Water-Reels are for the sole purpose of adding pressure to an incoming water supply. These pumps should **NEVER** be allowed to run dry. The pump seals will be damaged if the pump body is not full of water when the pump is running.



The Booster Pump engine is supplied with fuel from an auxiliary fuel tank mounted beside the engine. **Never refuel while the engine is running.**

Starting The Engine/Pump

Before attempting to start the engine check fuel and oil levels. The oil level is very important. Also check that the water flow control valve at the sprinkler cart is in the on position. **Water must be running through the pump.**

Start-up Procedure

1. Turn the ignition switch to `On`
2. The fuel line valve below the tank and valve on the engine must be `On`
3. If the existing water supply produces water flow that is too low the **Flow Switch** will prevent the engine from starting on units so equipped. To by-pass the Flow Switch depress the button mounted on the engine cover beside the gauge and hold down until the engine has started and the flow is sufficient for the engine to run with the by pass button released.
4. With the booster pump running a pressure increase should be observed on the machine pressure gauge. Use the engine throttle to control the water pressure. If there is no apparent increase in the water pressure, stop the engine and check the water supply.

Note: A pump inlet pressure gauge is installed to read the incoming line pressure. If this gauge shows little or no line pressure it is an indication that there is something wrong with the water supply. e.g. The supply line is too small or there is a restriction in the line.

Important - Please be sure to read and understand the following note.

Engine Choke

The choke lever on the booster pump engine may have a mid-position that can be used for engine warm-up. **It is imperative that the choke lever is in the full open position when the engine is in normal operation.**

The booster pump operation is such that the engine must accept full load as soon as it starts, therefore the engine may require a partial choke setting for a few seconds after starting. If the choke is left partially on, it will damage the engine. The oil will become contaminated with gasoline and/or a heavy carbon buildup will form inside the engine, which will make the engine seize.

Booster Pump Operating Instructions

Automatic Shutdown

At the completion of an irrigation run the engine will shutdown automatically if the sprinkler control selector valve on the guncart has been set to shut off the water supply. (See Page 14) Otherwise the engine will run until it is manually stopped.

Important Safety Message

If the automatic shutdown feature is in use or the nozzle becomes plugged and the pressure switch fails to stop the engine, the water inside the pump will become scalding hot. The booster pump is equipped with a high temperature valve, which discharges a small quantity of water to prevent the water in the pump from becoming too hot. The valve is located on the pump volute as indicated in the drawing below. It can also be installed in place of the drain plug. Do not operate this pump if this valve is not in place or is damaged. **Do not attempt to plug the discharge port of the high temperature valve!**

Maintenance (**Note.** New engines are shipped **without** oil!!!) Use Type SAE30 Oil Regularly check the engine oil level. Make periodic oil and air cleaner changes. Read the engine manufacturer's manual for instructions and maintenance procedures.

Oil Alert - Please note the following:

The Honda engines used on the booster pumps are equipped with a low oil level switch. If the engine becomes low on oil, it will stop. To avoid unwanted shutdown of the pump, it is important that the engine oil level be kept full.

Note: The dipsticks on the Honda engines are designed to indicate the proper oil level when the checking plug is unscrewed. Remove the dipstick, wipe it clean and check the oil level without screwing it back into the engine. Be sure to follow the engine manufacturers recommendations when checking the oil level. Just removing the plug and checking the level may give a false reading that is higher than actual oil level.

Winterizing

The pump must be drained of water. To drain the pump, remove the plug from the bottom of the pump body. Service the engine in preparation for the next season.

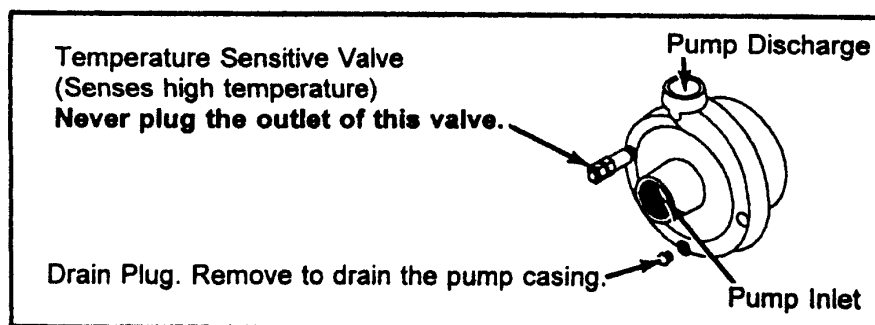

Optional Equipment

1. ***Booster Pump Kit***- 5HP & 9HP Booster.
2. ***Substitute Sprinklers*** – Refer to your dealer or Kifco.
3. ***2 Inch Feeder Hose and Fittings*** – See “Accessories Price List”

Kifco® Water Reel®

WARRANTY

KIFCO products are warranted to the original user for a period of one year from the date of his purchase invoice, that the equipment will be free from defects in material and workmanship subject to the following conditions:

Satisfaction of this warranty will be limited to the replacement or repair or modification of the equipment involved at the manufacturer's option. The manufacturer's obligation under this warranty shall be limited to a credit to the dealer or customer in the amount of the current list price of the parts or materials required for replacement, repair, or modification of the equipment.

Freight costs shall be paid by the dealer/customer.

This warranty extends only to the original user of KIFCO equipment purchased from an authorized KIFCO dealership.

This warranty does not apply to certain component parts used on KIFCO equipment. The original manufacturer warrants such component parts and KIFCO'S responsibility is limited to communicating the need for warranty service to each manufacturer. Such component parts include, but are not limited to tires and tubes, batteries, gearboxes, transmissions, pumps and sprinklers.

This warranty shall be available only if:

- A) KIFCO has received a properly executed delivery record and
- B) KIFCO is notified in writing within 30 days upon discovery of an alleged defect and
- C) KIFCO'S examination of the equipment discloses, to its satisfaction, that such alleged defect has not been caused by misuse; neglect; improper installation; improper operations; improper maintenance; repair or alteration; accident; or unusual or extraordinary use demands.

THE FOREGOING WARRANTY SUPERSEDES AND IS IN LIEU OF ALL OTHER WARRANTIES WHETHER EXPRESSED, IMPLIED OR STATUTORY, AND ALL OTHER LIABILITIES OR OBLIGATIONS ON THE PART OF KIFCO INC.

- A) KIFCO MAKES NO WARRANTY OF MERCHANTABILITY IN RESPECT TO THE EQUIPMENT.
- B) KIFCO MAKES NO WARRANTY THAT THE EQUIPMENT IS FIT FOR ANY PARTICULAR PURPOSE.

LIMITATION OF LIABILITY

KIFCO SHALL IN NO EVENT BE LIABLE FOR ANY CONSEQUENTIAL DAMAGES (INCLUDING BUT NOT LIMITED TO, DAMAGES FOR INJURY TO THE PERSON OR PROPERTY OR LOST PROFITS) OR ANY INCIDENTAL OR SPECIAL DAMAGES AND/OR EXPENSES, OR CLAIMS FOR INDEMNIFICATION, BY REASON OF ANY DEFECT IN THE EQUIPMENT OR ITS MANUFACTURE, DESIGN OR FUNCTIONING, OR ANY INSTRUCTIONS CONCERNING THE EQUIPMENT.

No agent or representative of KIFCO or any of its dealerships has authority to waive, alter or add to the printed provisions of this warranty and limitations of liability.

**KIFCO INC.
707 SOUTH SCHRADER AVE.
HAVANA, ILLINOIS 62644**

5/97