



Most Trusted Traveling Irrigation Systems Since 1964

Football Field Layouts

One Pass Irrigation

Model	B140	T180	T200S
Required Supply Pressure	106 PSI	87 PSI	80 PSI
Required Supply Pressure (With 5Hp Booster Pump)	56 PSI	37 PSI	30 PSI
Required Supply Pressure (With 9Hp Booster Pump)	33 PSI	14 PSI	7 PSI
Flow	53 GPM	53 GPM	53 GPM

The B140, T180 or T200S can irrigate a football field in a single pass with 53 GPM and a minimum pressure of 80 to 106 PSI. The T200S requires less pressure due to shorter hose and larger diameter.

All performance data based on Nelson SR75 with a .50" nozzle.

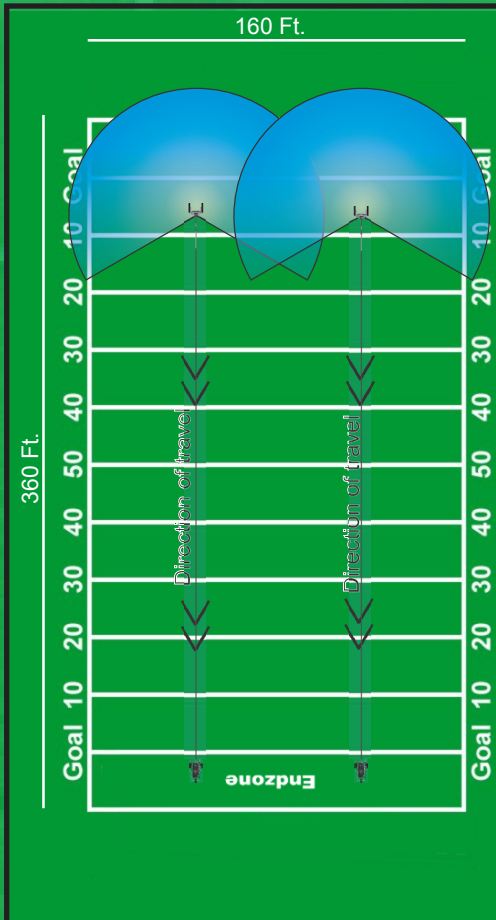
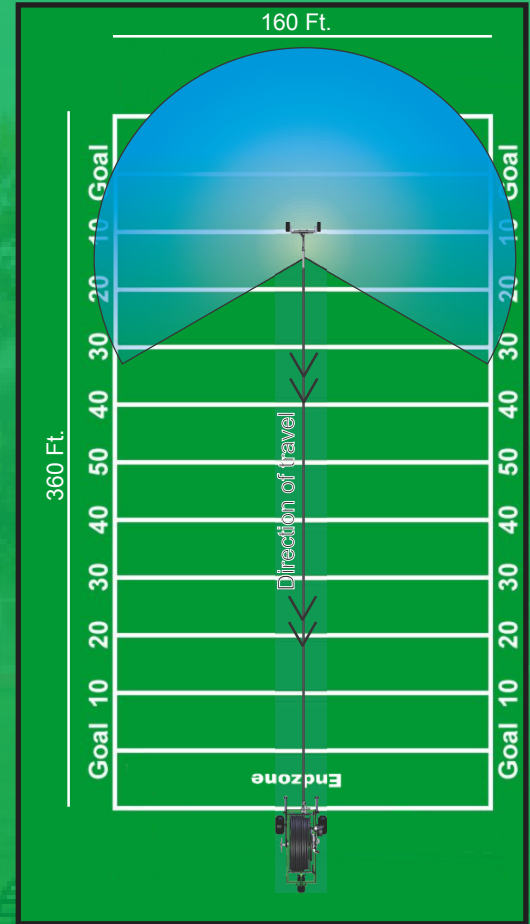

Two Pass Irrigation

Model	B110	B140
Required Supply Pressure	55 PSI	50 PSI
Flow	14 GPM	14 GPM

The B110 and B140 can irrigate a football field in two passes.

All performance data based on Sime K1 with 8mm nozzle.

All data contained herein are representative samples. Graphics may not be to scale as field dimensions and sprinkler performance vary. Please refer to model specific spec sheets for more detailed data.



700 S. Schrader Ave.
Havana, IL 62644
(800) 452-7017
www.kifco.com

Baseball Field Layouts

One Pass Irrigation

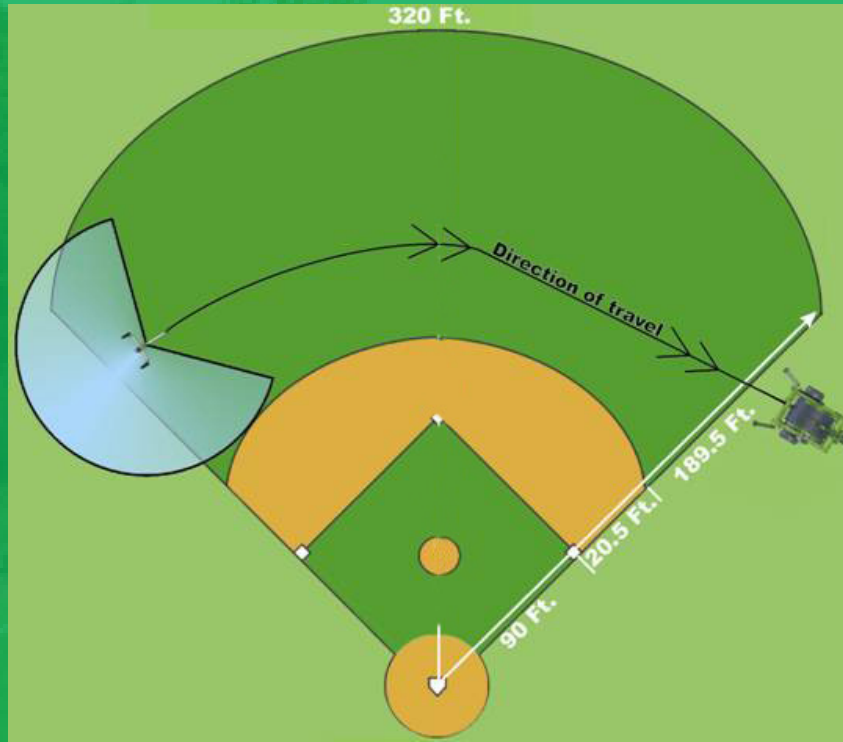

Kifco Water-Reels will follow the curve of a baseball field if pulled out along an arc. Note: The Water-Reel must be pulled out along an arc after a straight pull out of a minimum of 20% of the total tube length.

Model	B140	T180	T200S
Required Supply Pressure	90 PSI	81 PSI	77 PSI
Required Supply Pressure (With 5Hp Booster Pump)	40 PSI	31 PSI	27 PSI
Flow	42 GPM	42 GPM	42 GPM

The B140, T180 and T200S can all irrigate a baseball field in 1 pass with 35-40 GPM and a minimum pressure of 55 to 90 PSI. The T200S optimizes pressure and flow for the fastest application of water.

All performance data based on SR75 w/ a .45" nozzle

All data contained herein are representative samples. Graphics may not be to scale as field dimensions and sprinkler performance vary. Please refer to model specific spec sheets for more detailed data.



Most Trusted Traveling Irrigation Systems Since 1964

Soccer Field Layouts

One Pass Irrigation

Model	T200S
Minimum Inlet Pressure	104 PSI
Minimum Inlet Pressure (With 5 or 9Hp Booster Pump)	56 or 29 PSI
Flow	61 GPM

The T200S can all irrigate a soccer field in a single pass with 61 GPM and a minimum pressure of 29 to 104 PSI. The T200S requires less pressure due to shorter hose and larger diameter. All performance data based on Nelson SR75 w/ a .50" nozzle.

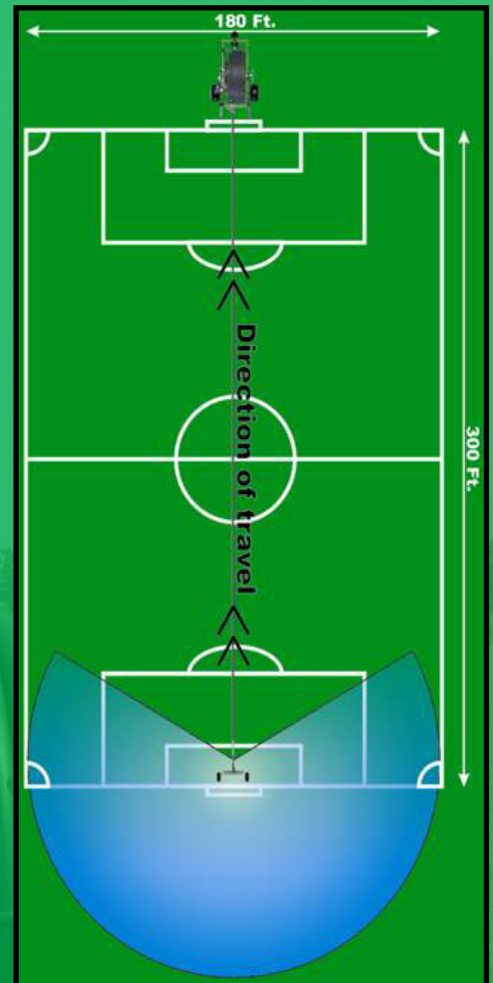

Two Pass Irrigation

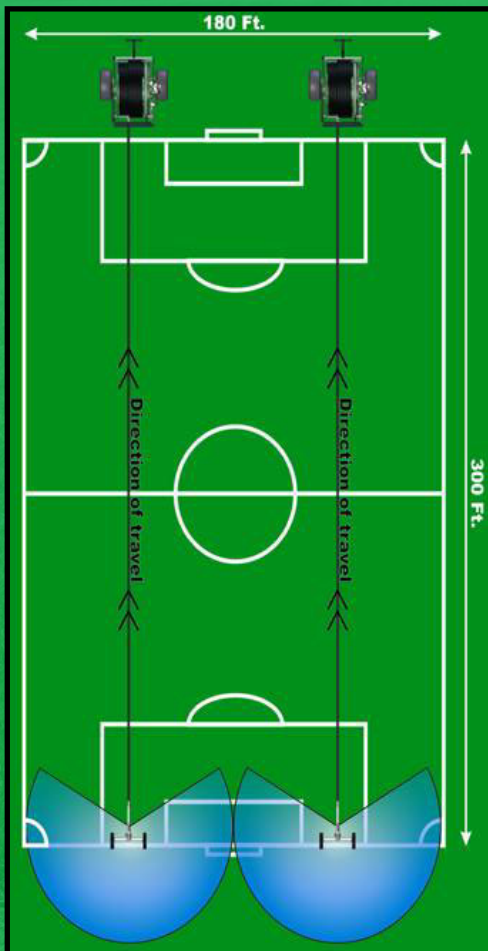

Model	B140	T180	T200S
Minimum Inlet Pressure	53 PSI	55 PSI	53 PSI
Flow	27 GPM	27 GPM	27 GPM

The B140, T180 and T200S can all irrigate a soccer field in 2 passes with less than 30 GPM and a minimum pressure of 55 PSI. The T200S requires less pressure due to shorter hose and larger diameter.

All performance data based on SR75 w/ a .40" nozzle.

All data contained herein are representative samples. Graphics may not be to scale as field dimensions and sprinkler performance vary. Please refer to model specific spec sheets for more detailed data.



700 S. Schrader Ave.
Havana, IL 62644
(800) 452-7017
www.kifco.com



Most Trusted Traveling Irrigation Systems Since 1964

Polo Field Layouts

Polo Field Dimensions: 900 ft. x 480 ft.

Model	T30/980	T37/1220
Minimum Inlet Pressure	71 PSI	106 PSI
Flow	100 GPM	260 GPM
Irrigated Width (70% of Wetted)	172 Ft.	238 Ft.
Passes Necessary	3	2
Nelson SR 150 Nozzle*	.86"	1.18"

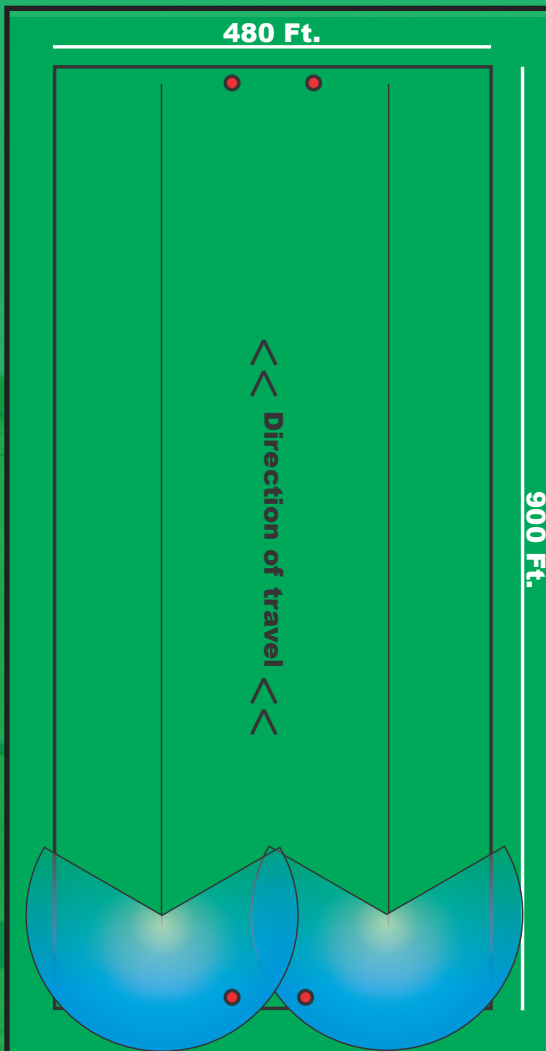

T37x1220

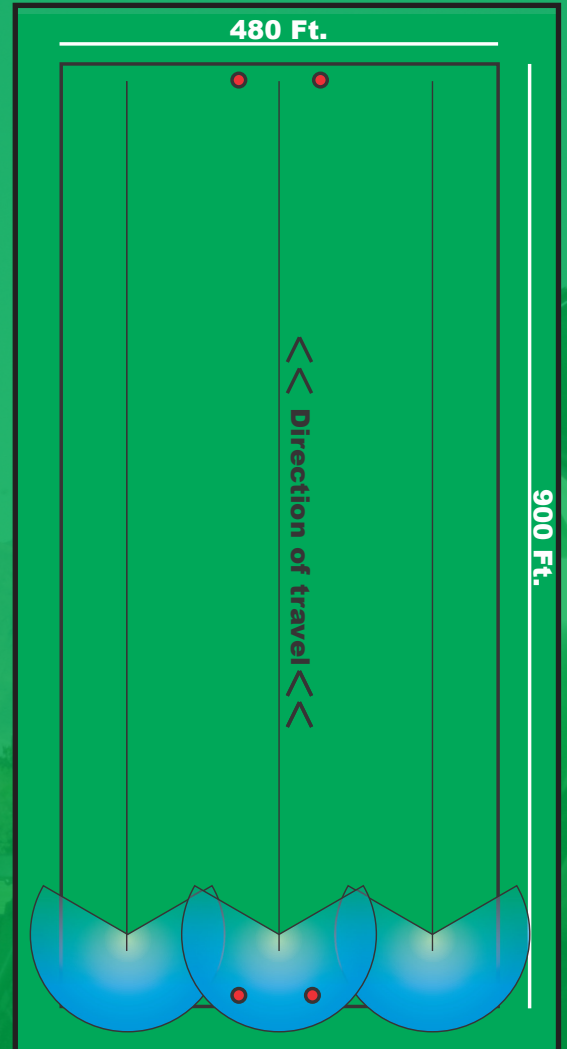

T30/980

All data contained herein are representative samples. Graphics may not be to scale as field dimensions and sprinkler performance vary. Please refer to model specific spec sheets for more detailed data.



700 S. Schrader Ave.
Havana, IL 62644
(800) 452-7017
www.kifco.com



Most Trusted Traveling Irrigation Systems Since 1964

Synthetic Turf Field Layouts

One Pass Irrigation

Model	E200SST
Minimum Inlet Pressure	98 PSI
Minimum Inlet Pressure (With 5 or 9Hp Booster Pump)	70 or 40 PSI
Flow	106 GPM

Note: The E200SST is specifically designed for application of water to cool and condition all types of synthetic turf. The machine will apply .1" to .2" of water to the playing surface in less than 30 minutes. The machine is equipped with a dual gun, gun cart for speed of water application.

All performance data based on Nelson SR75 with a .50" nozzle.

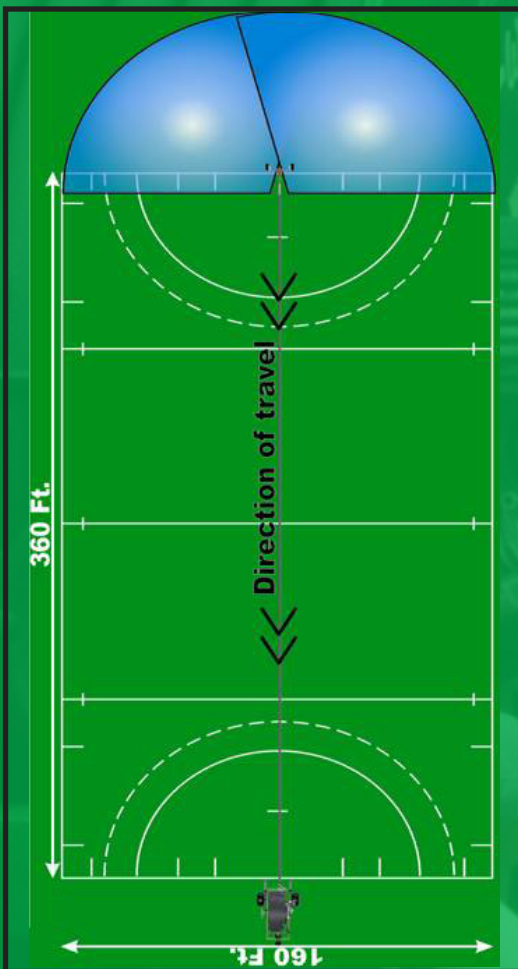

Hockey Field

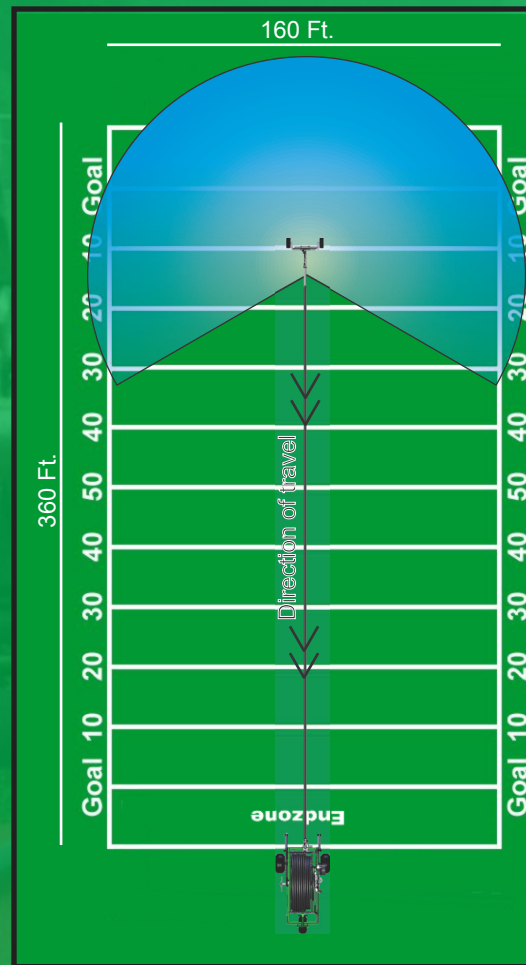

Football Field

All data contained herein are representative samples. Graphics may not be to scale as field dimensions and sprinkler performance vary. Please refer to model specific spec sheets for more detailed data.



700 S. Schrader Ave.
Havana, IL 62644
(800) 452-7017
www.kifco.com

Cricket Field Layouts

Featured Models for Cricket Field Irrigation

Model	E110	B140	T200L	T23x600
Required Minimum PSI	23	81	60	74
Minimum Flow (GPM)	3	18	28	74

Kifco has a wide range of models to choose from and application designs for your cricket field irrigation. Below are several sample application designs as examples. For a detailed layout of your sports field complex, contact Kifco or your local Authorized Kifco Dealer.

Pitch coverage with an E110 Water-Reel

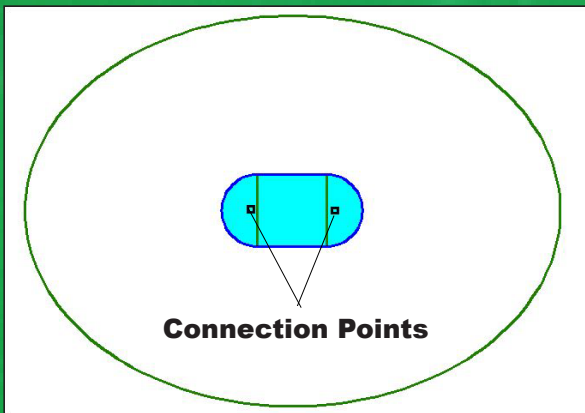

Complete Coverage with B140 Leaving Pitch Area Dry for More Frequent Light Coverage

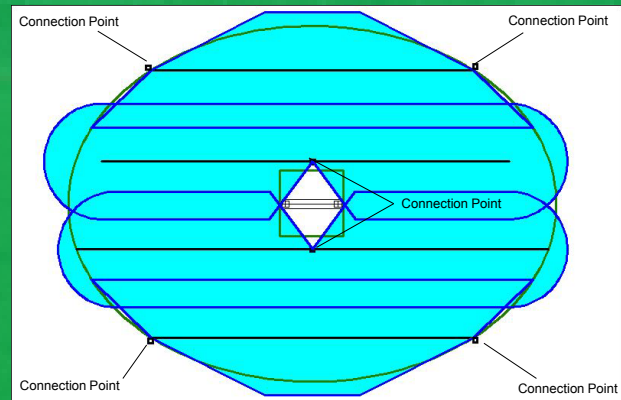

The T23x660 w/ computer control option for delayed start is an excellent system to easily manage and irrigate up to 5 fields in the general area.

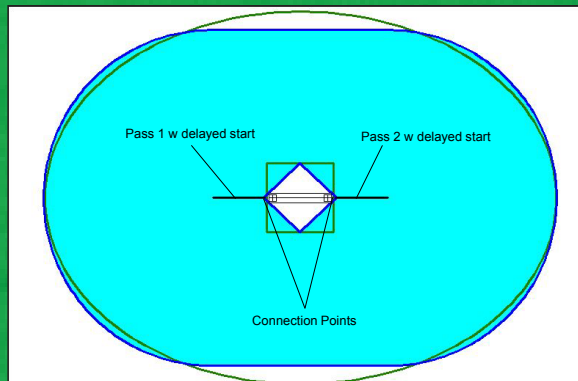

The T200L can cover the entire outfield and infield with fewest moves & connection points. Central pass shown.

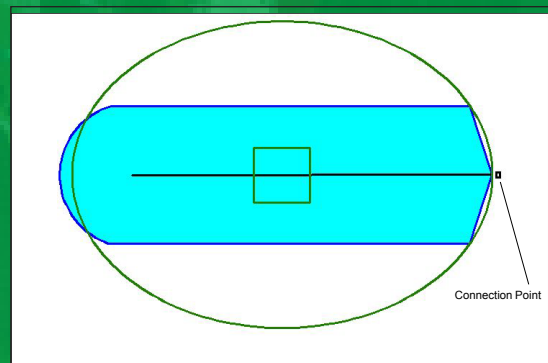

All data contained herein are representative samples. Graphics may not be to scale as field dimensions and sprinkler performance vary. Please refer to model specific spec sheets for more detailed data.

Common Water Reel Applications with Suggested Models

Please refer to model specific spec sheets for further information.

Sports Fields
(Natural Grass)



No In-Field Obstructions

B110/E110
B140/E140
T180
T200S

Sports Fields
(Synthetic Turf)



Quickly Cools Playing Surfaces

E180 ST
E200SST
E200LST
E210LST

Indoor & Outdoor
Horse Arenas



Improves Footing

E110
B110
E180 ST
E200SST
E200LST
E210LST

Pastures & Paddocks



Quickens Re-Growth

B-Series Water-Reels
(perfect for smaller areas)
Ag-Rain Water-Reels
(for more acreage)

Common Water Reel Applications with Suggested Models

Please refer to model specific spec sheets for further information.

Ranches & Hobby Farms



Increases Property Values

B-Series Water-Reels
Ag-Rain Water-Reels

Polo Fields



Lowers Labor Costs

T30x980
T37x1220
T40x1250

Vegetables & Produce



High Quality

B-Series Water-Reels
(perfect for smaller areas)
Ag-Rain Water-Reels
(for more acreage)

Agricultural Irrigation



Increased Production

Ag-Rain Water-Reels

Common Water Reel Applications with Suggested Models

Please refer to model specific spec sheets for further information.

Slurry & Waste Disposal



Passes Large Solids

Engine Drive
Ag-Rain Water-Reels

Food Plots



Attracts Game

B110
E110
B140
E140
T200S
T200L
T200LSC

Dust Suppression
(Construction, Mining,
Feed Lots, etc.)



Healthier Environment

B110 E180 ST
E110 E200SST
E140 E200LST
T180
T200S
T200L
T210

Composting or
Waste Water Reuse



Increased Production

Engine Drive B-Series and
Ag-Rain Water-Reels

Common Water Reel Applications with Suggested Models

Please refer to model specific spec sheets for further information.

Golf Courses, Parks & Recreation



Excellent For Hard To Reach Areas

B110/E110
B140/E140
T200S
T200L
T200LSC

Residential Landscape, Gardens & Nurseries



Beautifies Overall Landscape

B110
E110
B140
E140
T180
T200S
T200L
E200SST

Hydroseeding, Reclamation and Establishment



Quickly Establishes New Landscaping

B-Series and Ag-Rain Water-Reels

Cemeteries



Increases The Value Of Burial Plots

B110/E110
B140/E140
T180
T200S



*Exclusively for You,
the Dealer!*

Selling Water-Reels Has Never Been Easier!

With Kifco Reel Design, you will be able to create designs of your customer's actual property, prepare quotations and bill of materials all in one report and without ever leaving your computer!

A first of its kind tool to aid in the design and quotation of Kifco® Water-Reels®.

Designs



Reel Design utilizes state of the art Satellite Imagery which allows you and your customer to select the actual field or area of land to be irrigated. Handing over a complete design of your customer's actual property is sure to impress!

Bill of Materials



As items are selected during your design, they are automatically compiled into a Bill of Materials. From the pipe in the ground to the nozzle on the end of your sprinkler, you will easily be able to show your customer exactly what's needed for the job.

Quotations



With up to date pricing included, professional quotations are simply added to the final report. Your logo is included to give your reports that personal touch.

Manage with Less Guess

Work

With allowances for pipe type & diameter, friction loss and even head gain or loss due to elevation changes, Reel Design can precisely select the right equipment needed for any project!

Leading the Way

At Kifco we recognize that the ability to effectively stand apart from the rest is highly dependent on keeping our dealers supplied with marketing and training materials to aid in the sale. Kifco Reel-Design is just one more tool that will allow us to continue to lead the competition in traveling irrigation sales & service.

Get Started Today

Simply watch the training video by copying & pasting the following link in your web browser:

<https://youtu.be/JEdOtDaDf3k>



Most Trusted Traveling Irrigation Systems
Since 1964

Ag Layouts

Lost Corners



Supply:
26 gpm @ 105 psi

220' of 2" CL 160

2.2 Ac (21.5%)

B110 or E110

Example with 26 gpm and 100 psi

Per Day 1 Corner .58"	Per Day 4 Corners 4.1"	Per Week 1 Corner .14"	Per Week 4 Corners 1.0"
------------------------------------	-------------------------------------	-------------------------------------	--------------------------------------

660 ft

Ag Layouts

Lost Corners



Supply:
60 gpm @ 105 psi

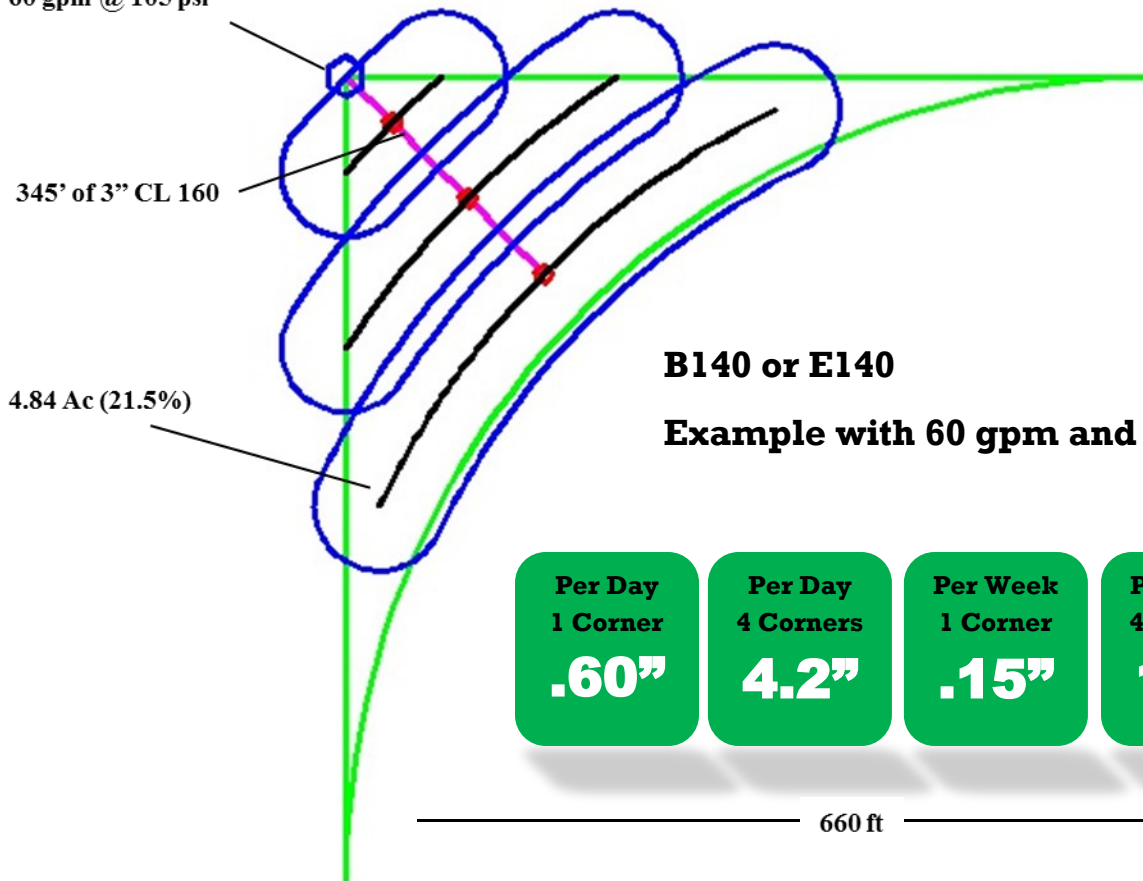

B140 or E140

Example with 60 gpm and 100 psi

Per Day 1 Corner .60"	Per Day 4 Corners 4.2"	Per Week 1 Corner .15"	Per Week 4 Corners 1.0"
------------------------------------	-------------------------------------	-------------------------------------	--------------------------------------

Ag Layouts

Lost Corners



Supply:
85 gpm @ 105 psi

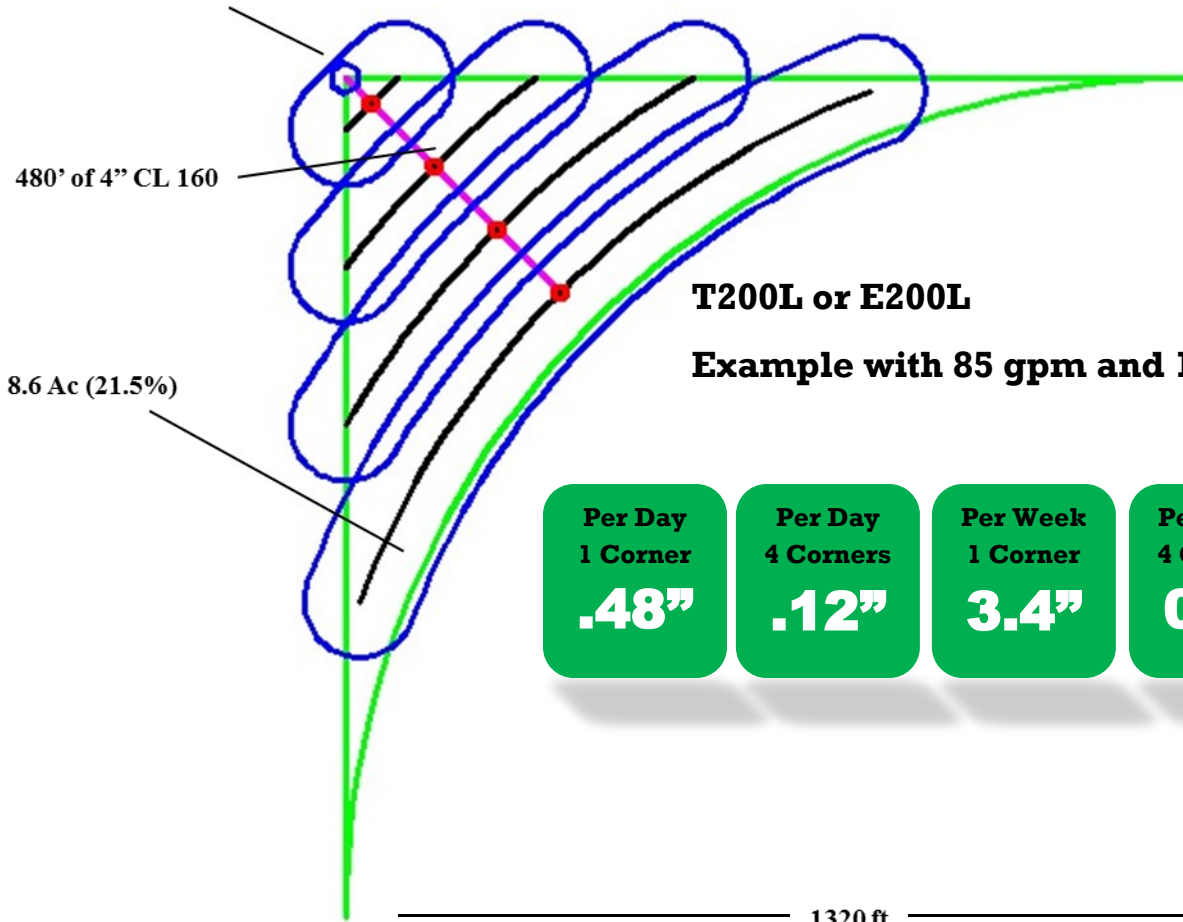

T200L or E200L

Example with 85 gpm and 100 psi

Per Day 1 Corner .48"	Per Day 4 Corners .12"	Per Week 1 Corner 3.4"	Per Week 4 Corners 0.8"
------------------------------------	-------------------------------------	-------------------------------------	--------------------------------------

Ag Layouts

Lost Corners



Supply:
245 gpm @ 105 psi

480' of 6" CL 160

8.6 Ac (21.5%)

T30x660 or E330 660

Example with 245 gpm and 100 psi

Per Day 1 Corner 1.0"	Per Day 4 Corners .24"	Per Week 1 Corner 6.9"	Per Week 4 Corners 1.7"
------------------------------------	-------------------------------------	-------------------------------------	--------------------------------------

1320 ft

Ag Layouts

Lost Corners

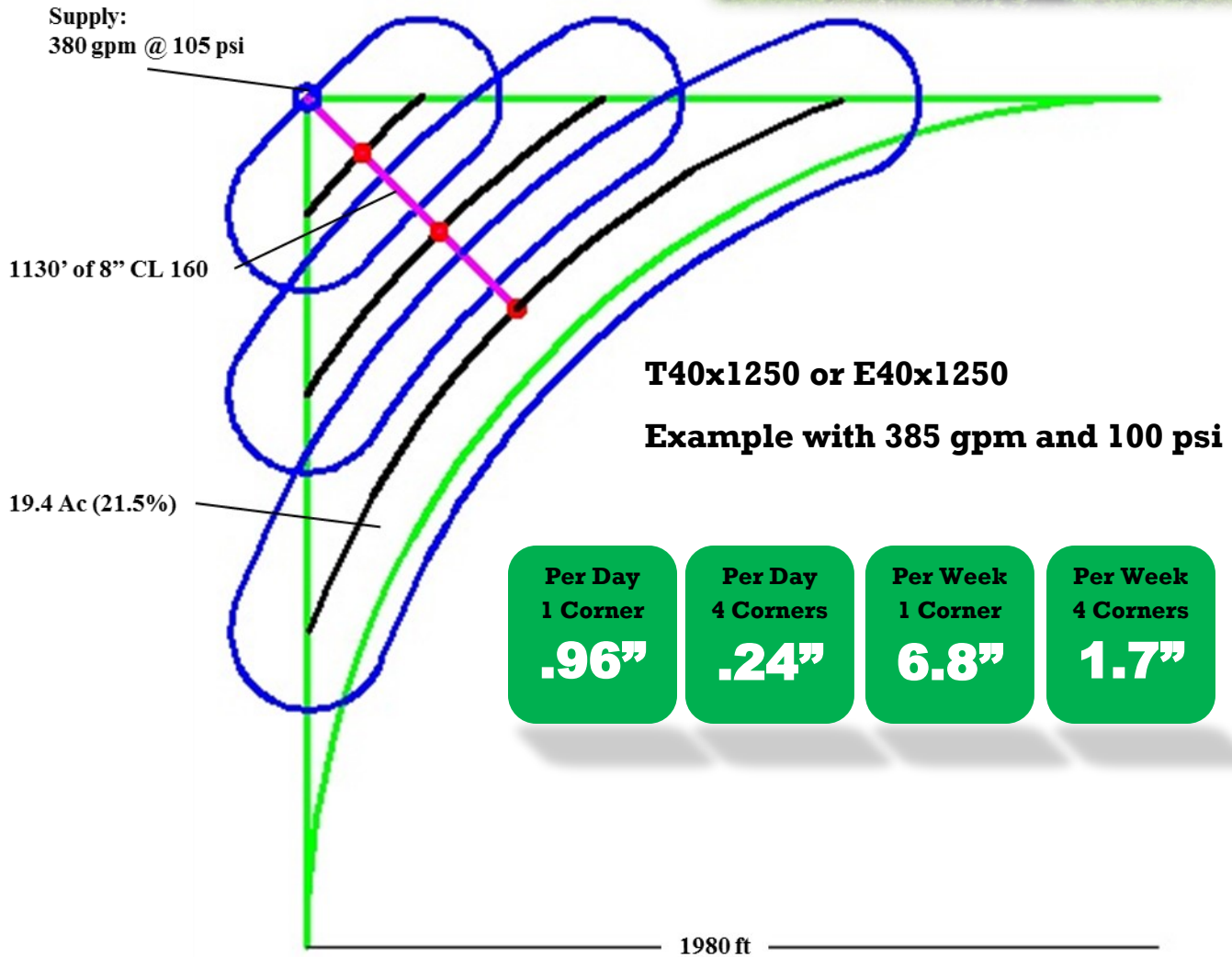

Ag Layouts

Lost Corners

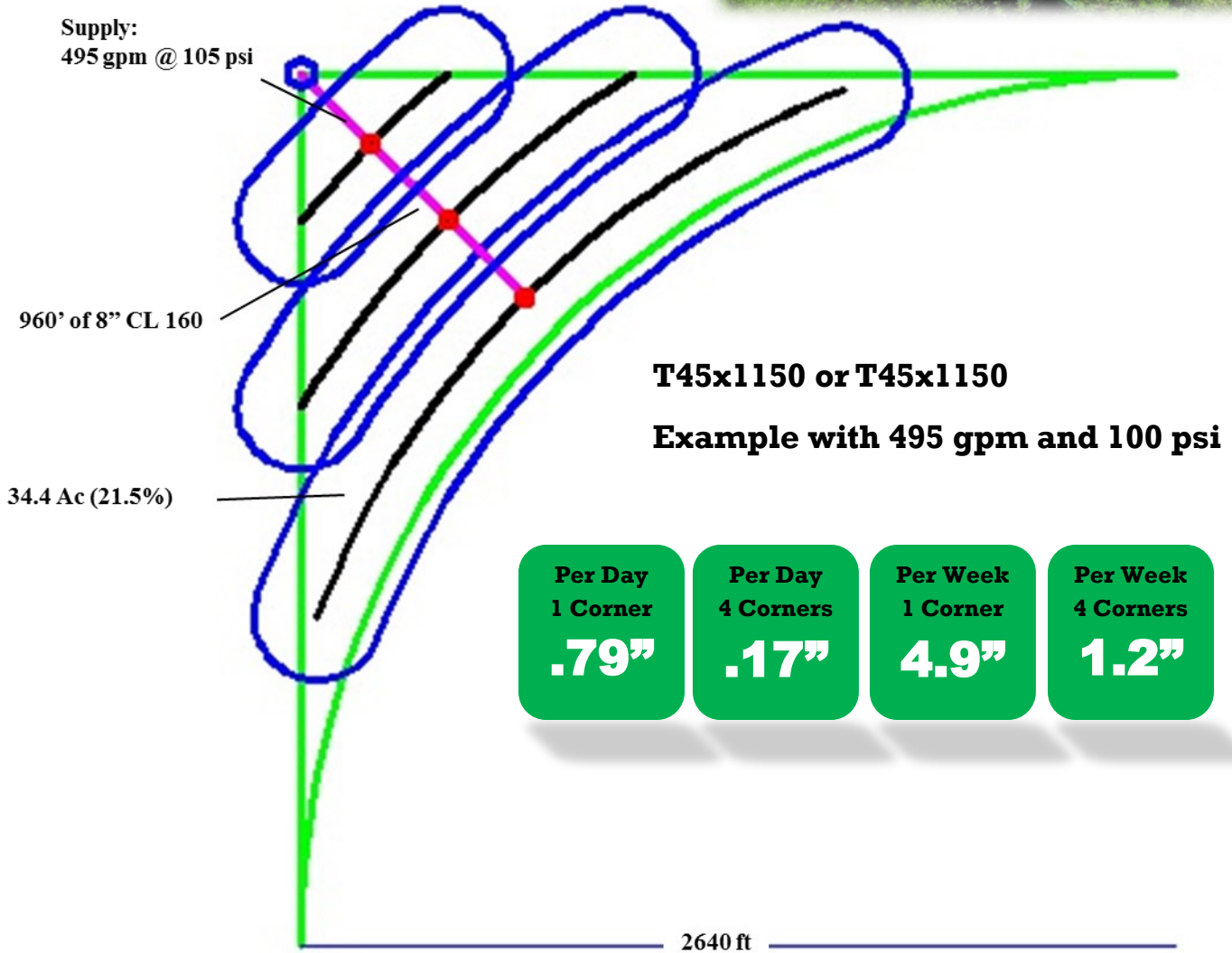

Ag Layouts

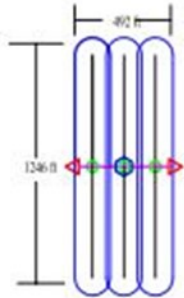

14.1 Ac, .35"/day
Water-Reel 2014 MSRP : \$772/Ac

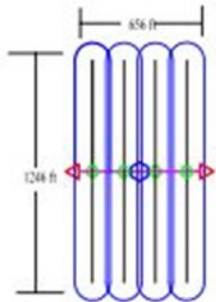

118.8 Ac, .27"/day
Water-Reel 2014 MSRP : \$579/Ac

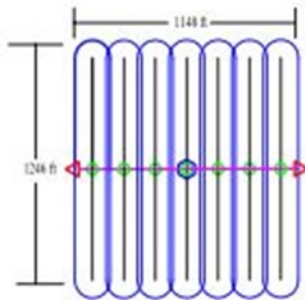

32.8 Ac, .15"/day
Water-Reel 2014 MSRP : \$331/Ac



T200L

100gpm @ 104psi inlet

Dw = 184', W = 164', Li = 623', 2.34 ac/pass

Ag Layouts

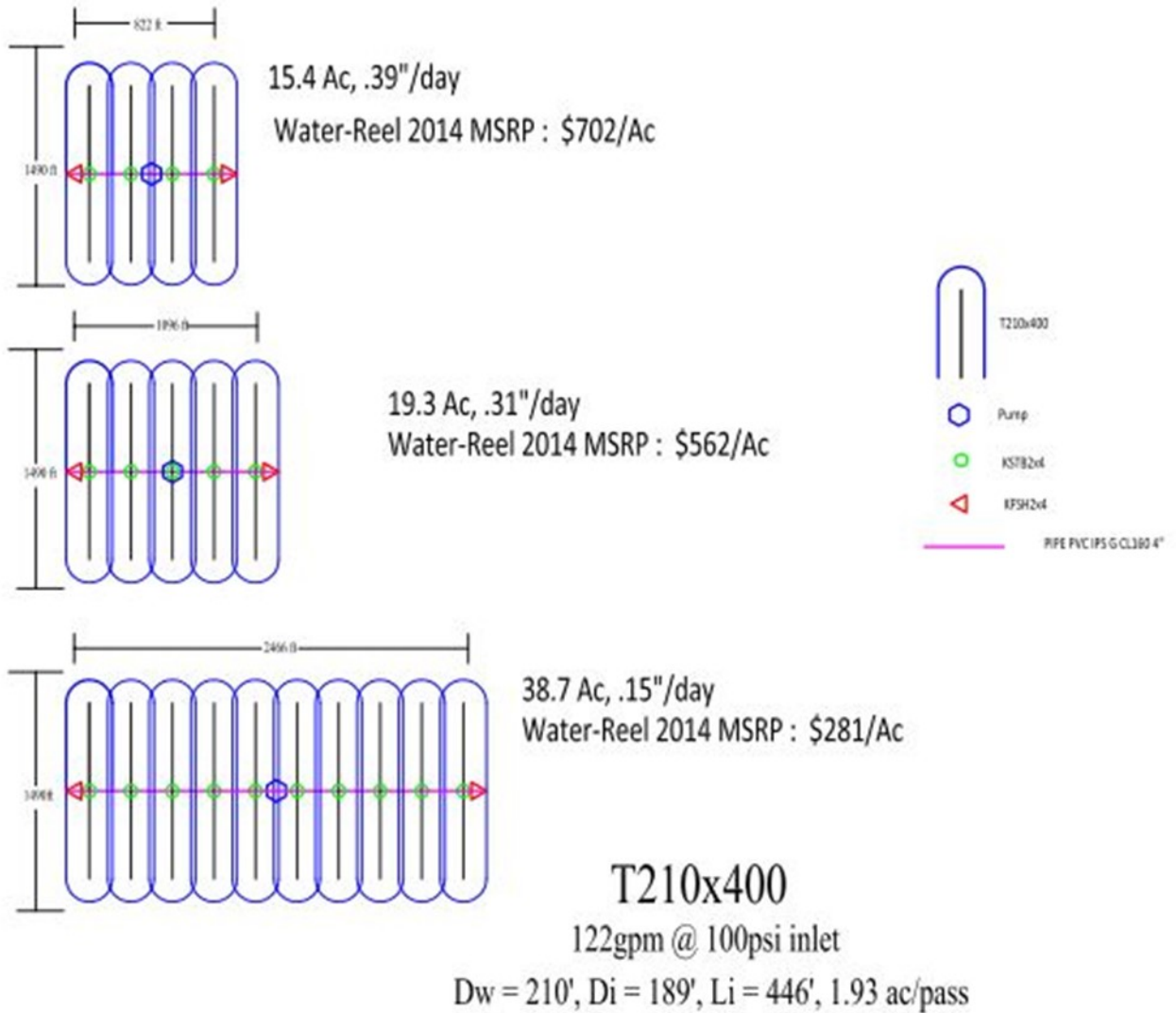

Ag Layouts

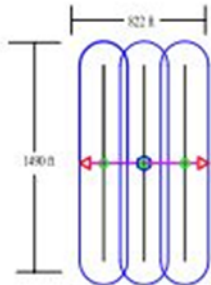

28.1 Ac, .45"/day
Water-Reel 2014 MSRP : \$720/Ac

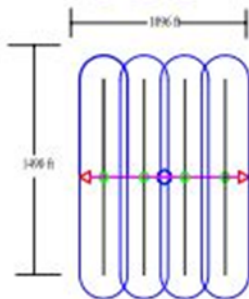

37.4 Ac, .33"/day
Water-Reel 2014 MSRP : \$540/Ac

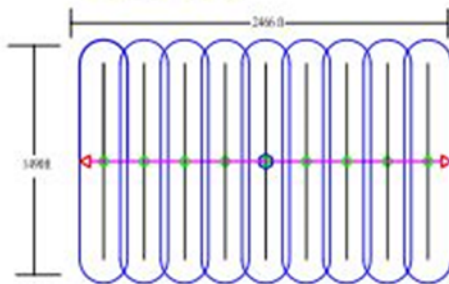

84.2 Ac, .15"/day
Water-Reel 2014 MSRP : \$240/Ac

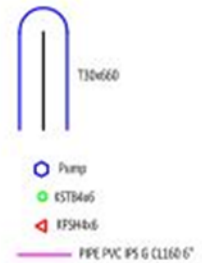

T30x660 systems
257gpm @ 104psi inlet

Dw = 322', Di = 274', Li = 744', 4.68 ac/pass

Ag Layouts

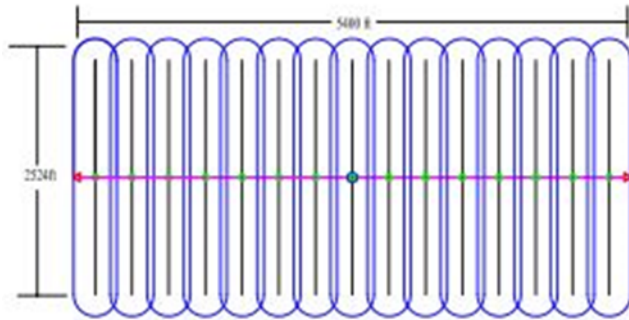

184.2 Ac, .15"/day
Water-Reel 2014 MSRP : \$250/Ac

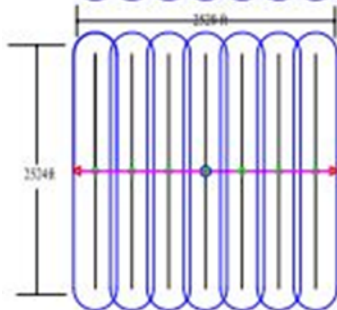

85.9 Ac, .31"/day
Water-Reel 2014 MSRP : \$535/Ac

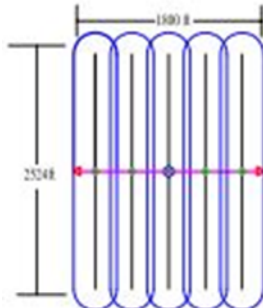

61.4 Ac, .43"/day
Water-Reel 2014 MSRP : \$745/Ac

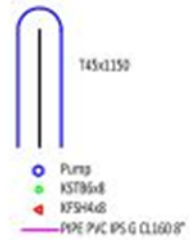

T45x1150 systems

542gpm @ 104psi inlet

Dw = 424', Di = 360', Li = 1262', 6.14ac/pass

Ag Layouts

T200L or E200L

82 gpm w 100 psi @ the inlet.

Gives .32"/day (2.25"/wk)

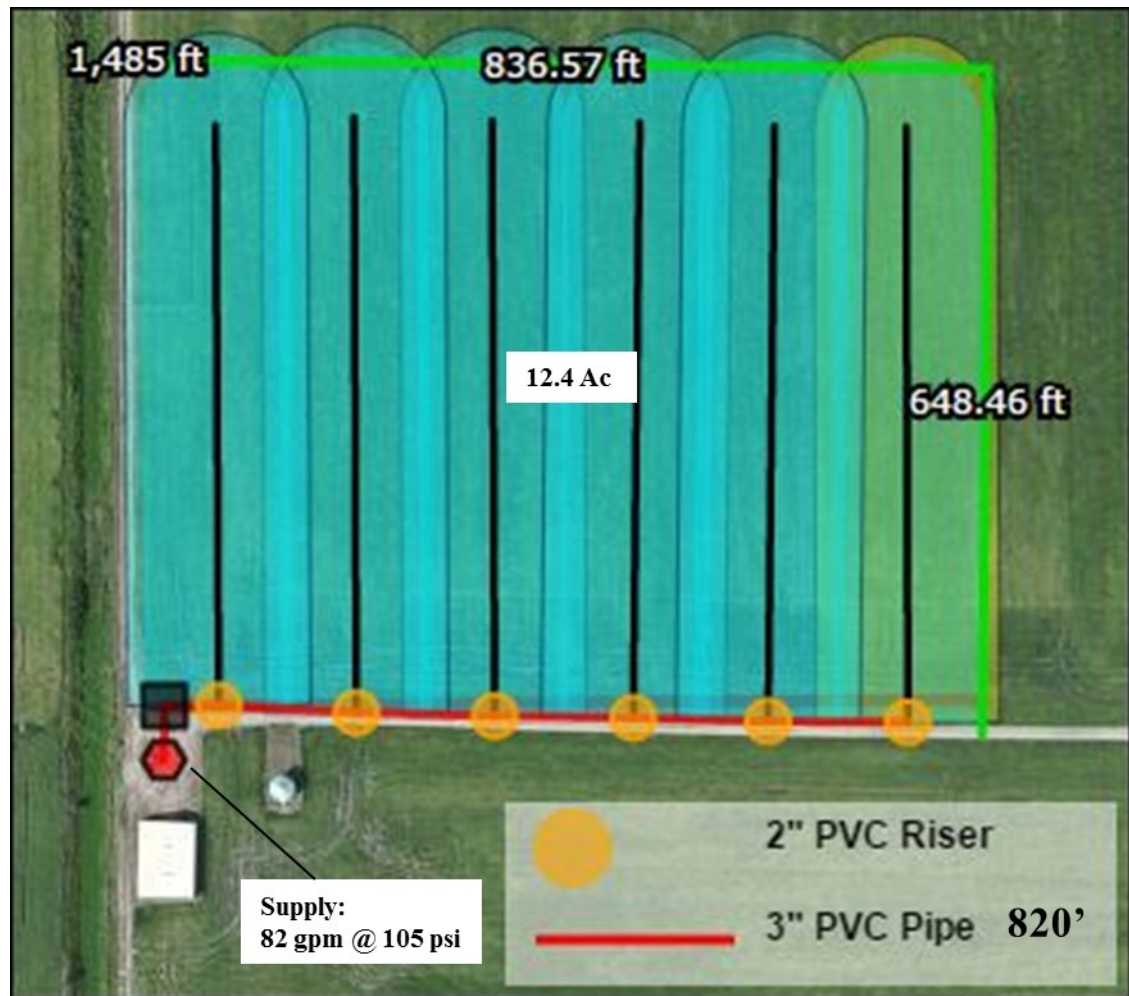

Ag Layouts

T200L 82 gpm w 100 psi @ the inlet.
Gives .22"/day (1.5"/wk)

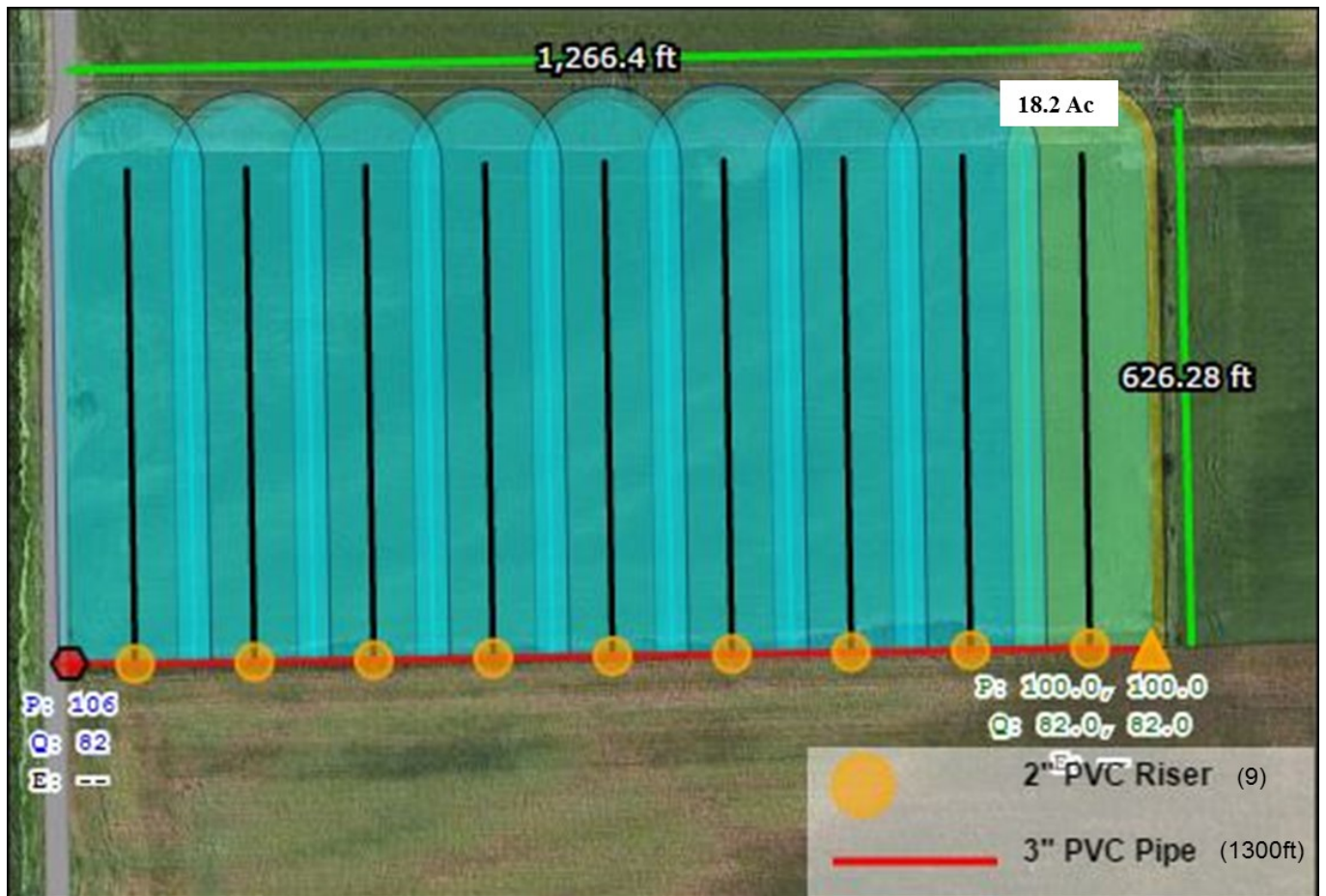

 Pump: Model #####

 2"x3" KFLSH (1)

Ag Layouts

23 Ac, .25'/day, 1.75"/wk

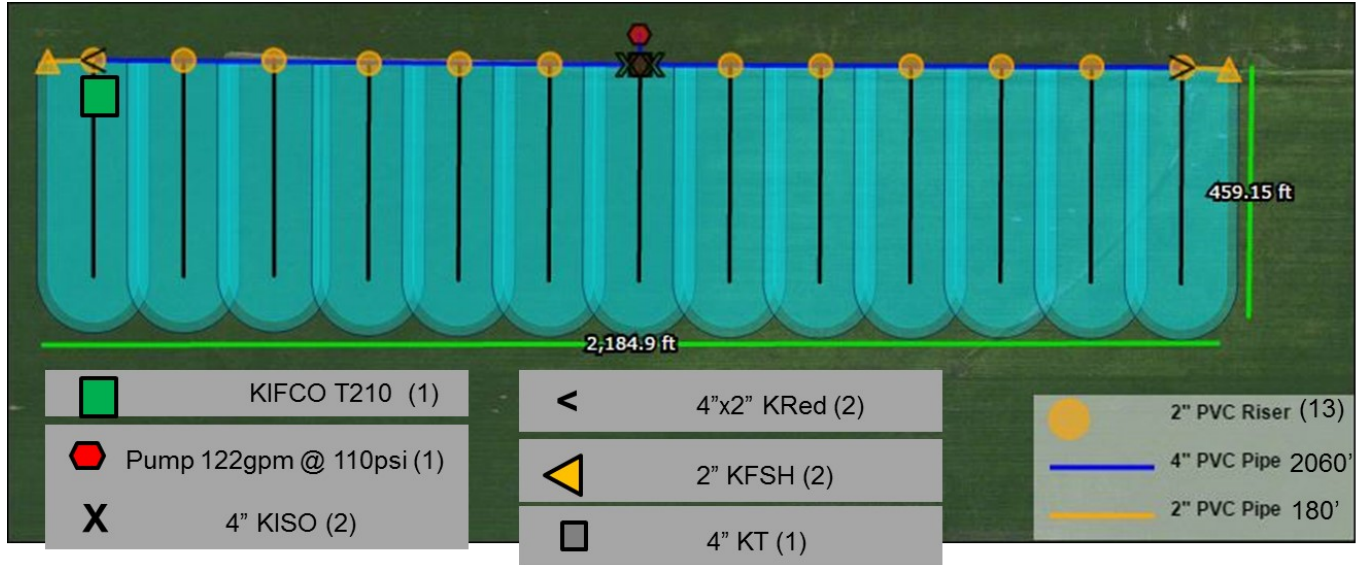

Ag Layouts

17.7 Ac, .32'/day, 2.24"/wk

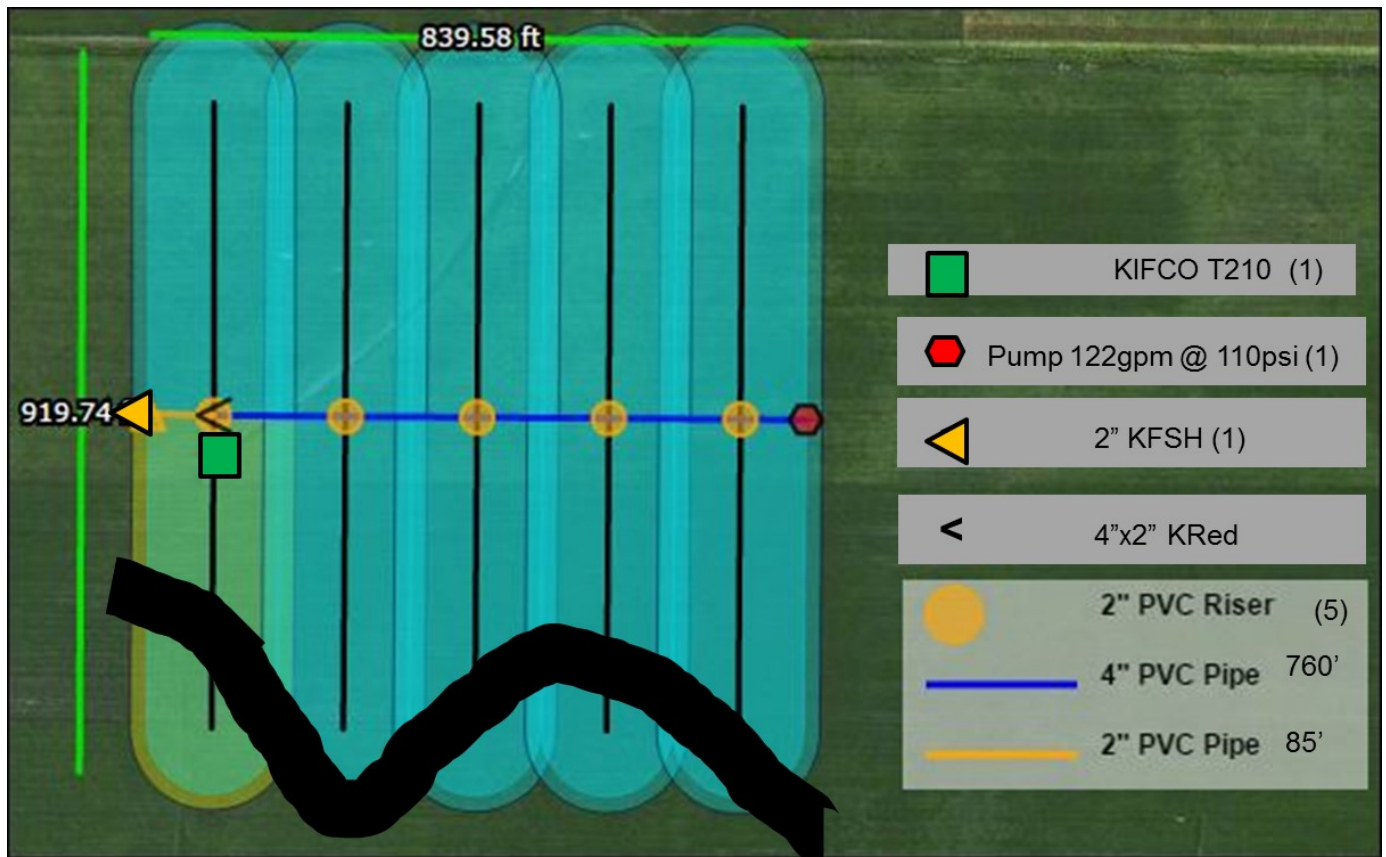

Ag Layouts

Cost-Effective Operation

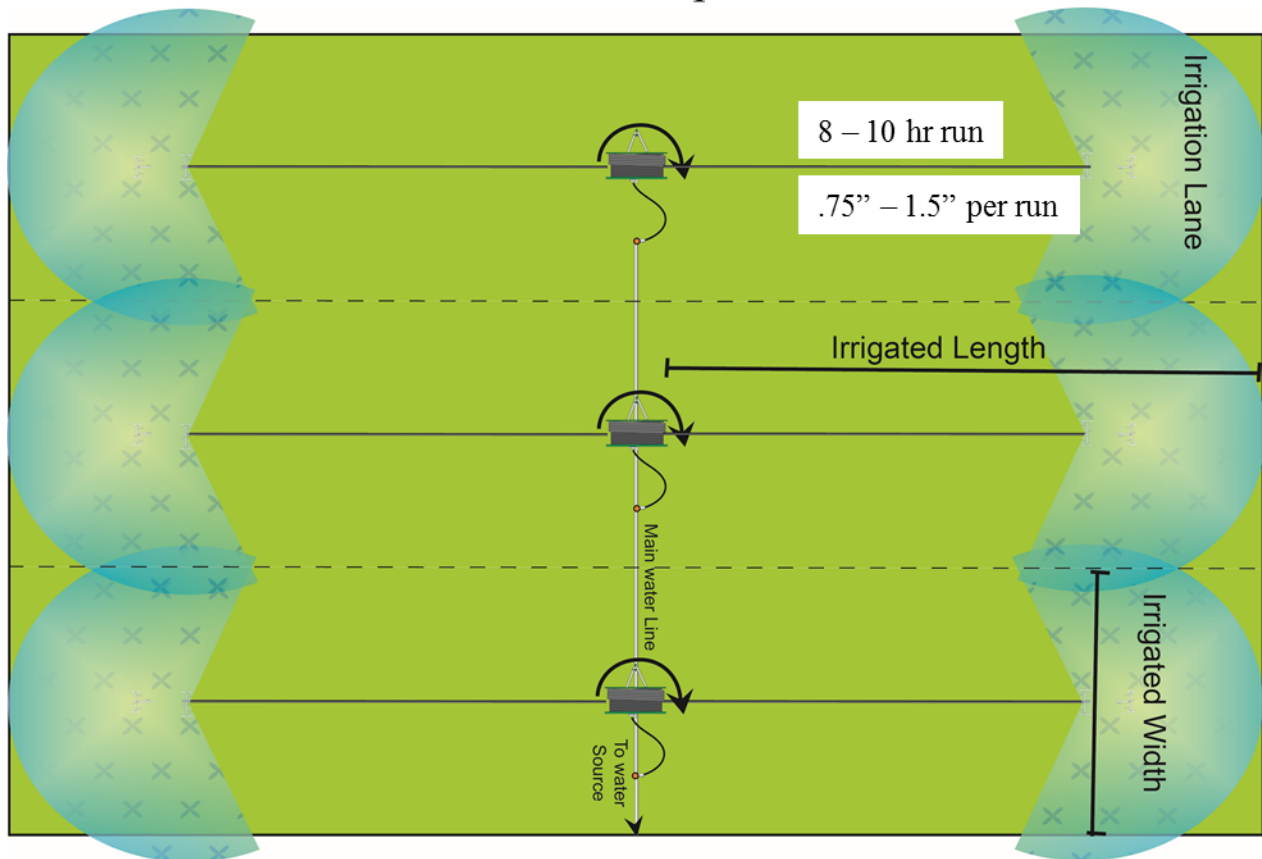

20 – 23 hrs /day operation w two 30 minute visits per day

Details in Installation - For Water-Reel Models B110 & E110

KSTB1.5Q Details

Isolation valve and French drain recommended for use in freezing temperatures.

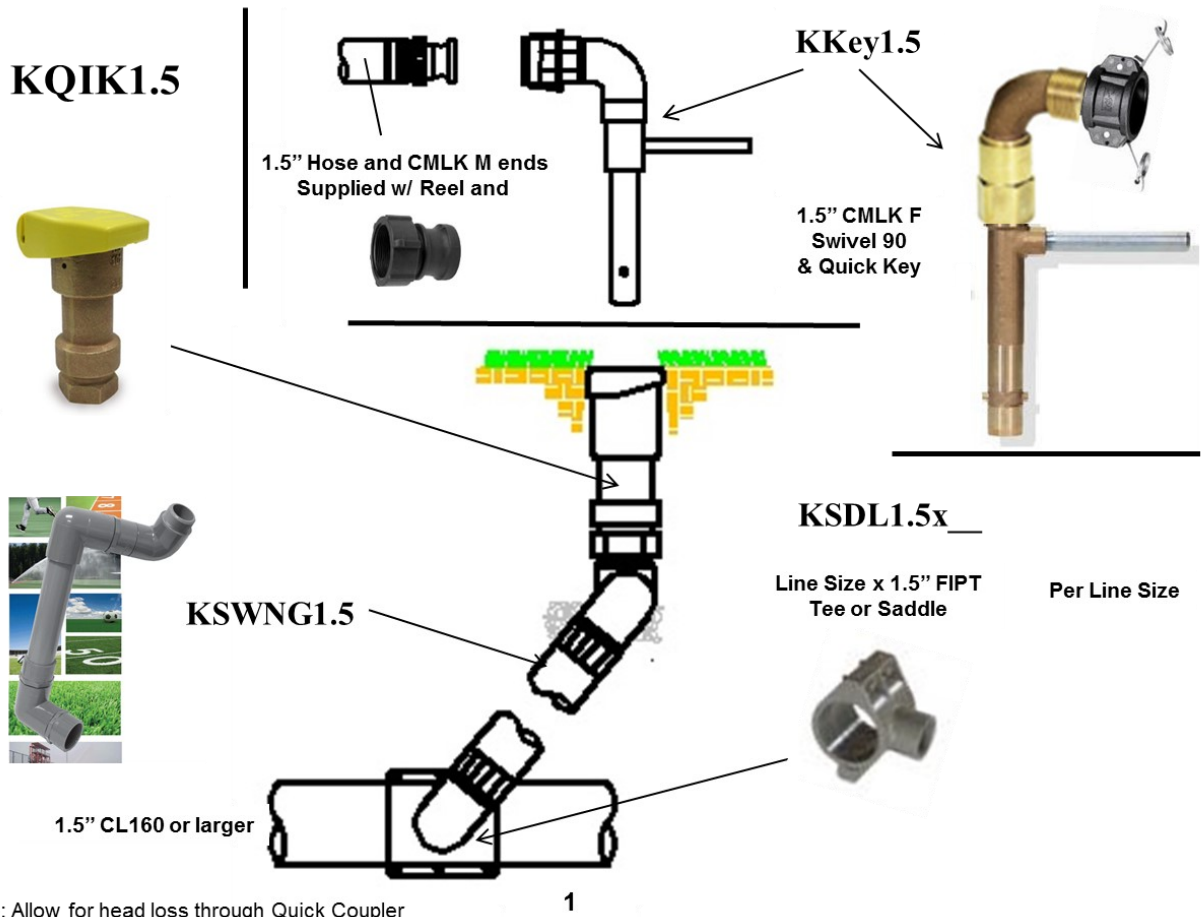

KSTB1.5Q

Details in Installation - For Water-Reel Models B110, E110, B140 & E140

KSTB1.5 Details

Isolation valve and French drain recommended for use in freezing temperatures.

KSTB1.5x Assembly

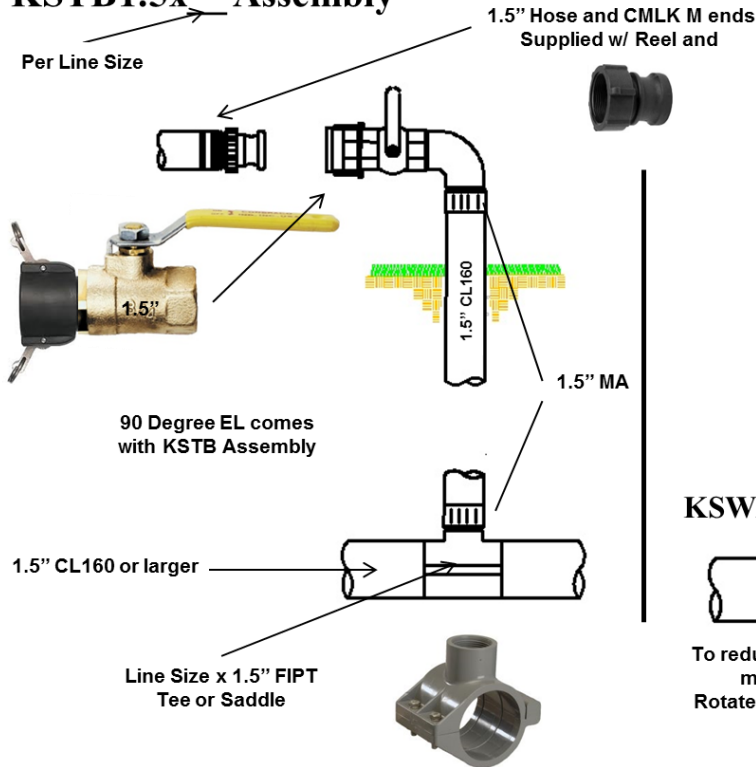

KSTB1.5

2

KBOX1.5

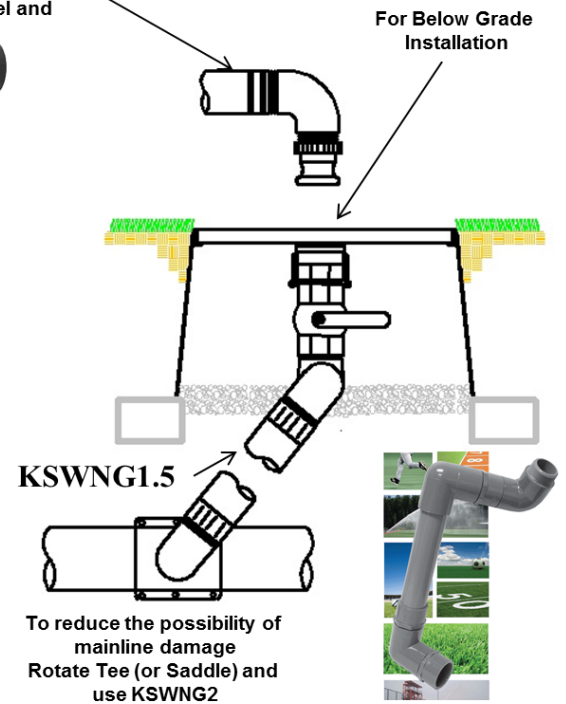

Details in Installation - For Water-Reel Models B110, E110, B140 & E140

KSTB1.5 Details

Isolation valve and French drain recommended for use in freezing temperatures.

KSTB1.5x Assembly

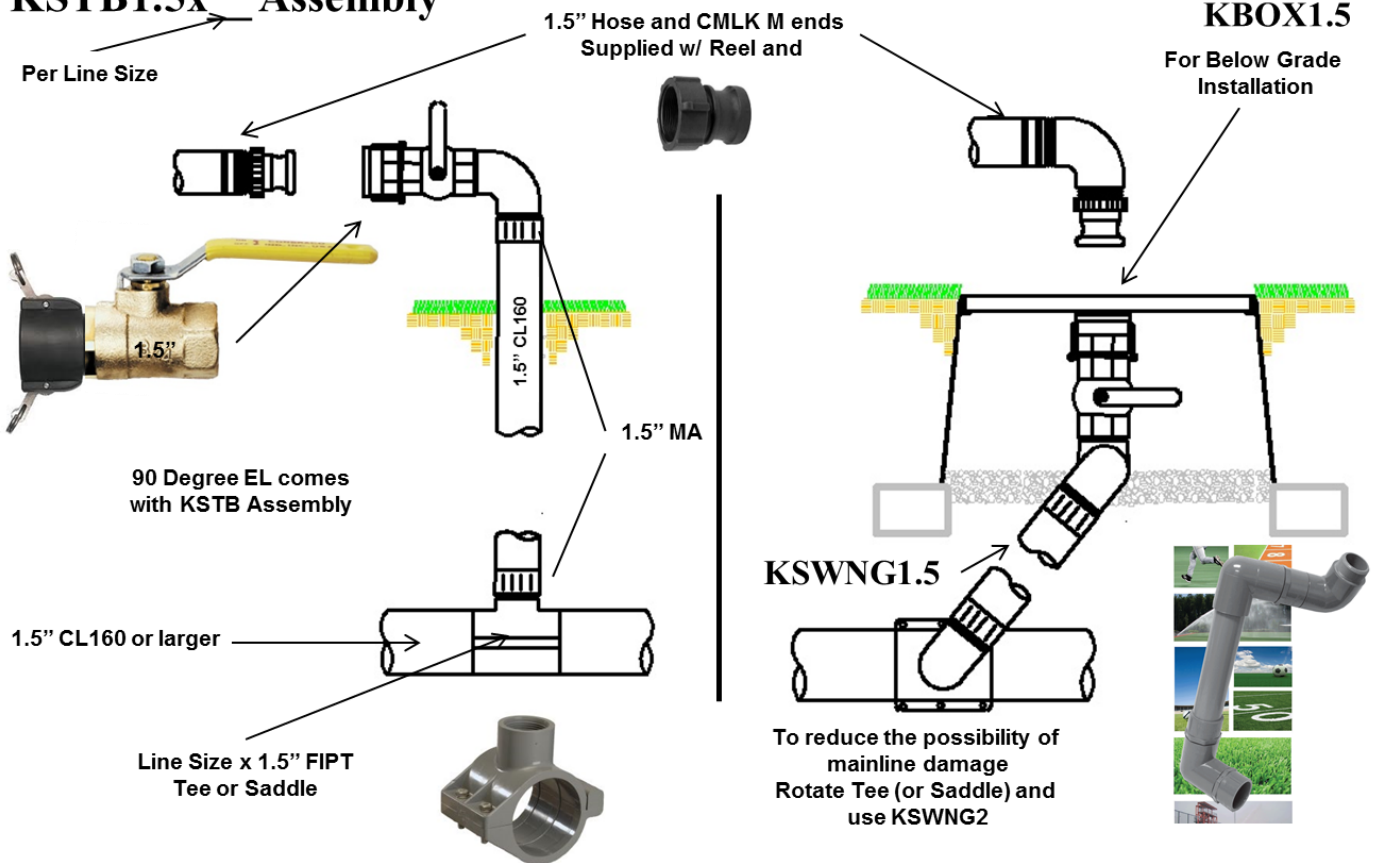

KSTB1.5

Details in Installation - For Water-Reel Models T180, T200S, T200L & T210

KSTB2 Details

Isolation valve and french drain recommended for use in freezing temperatures.

KSTB2x Assembly

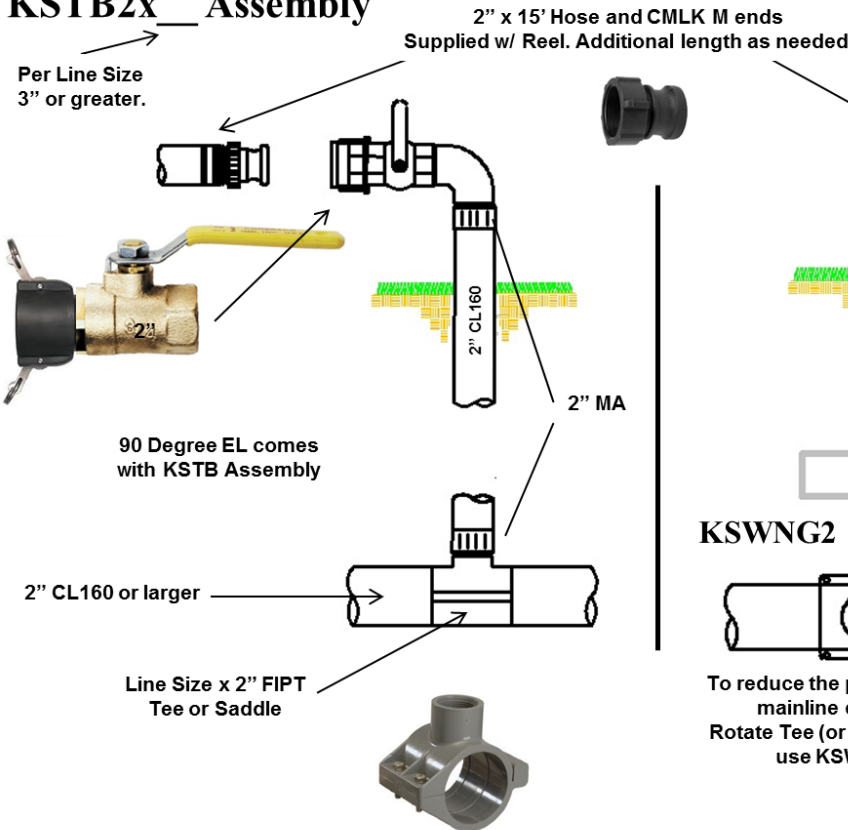

KBOX2

For Below Grade Installation

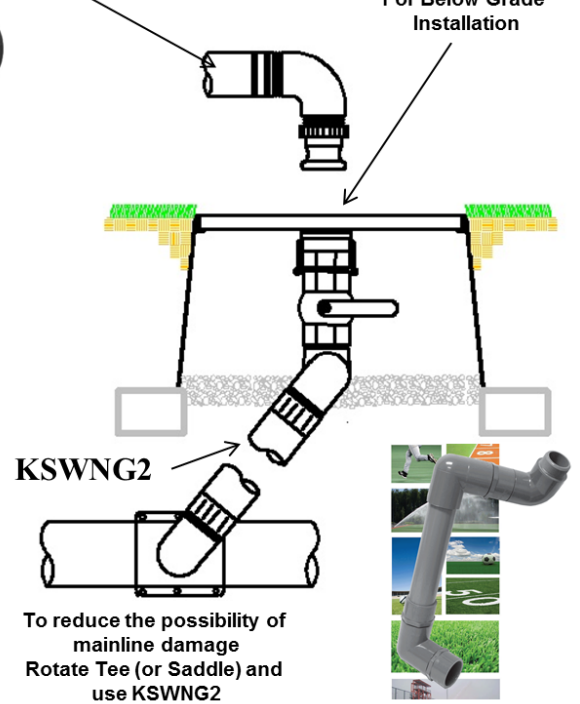

KSTB2

Details in Installation - For Water-Reel Models T200L, T210, T23x600, T27x980, T30x660, T30x980, T30x1200 & T33x1120

STUB4 Details

Isolation valve and French drain recommended for use in freezing temperatures.

KSTB4x Assembly

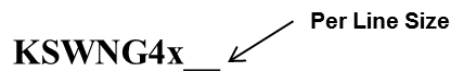
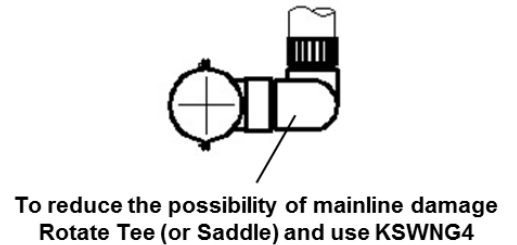
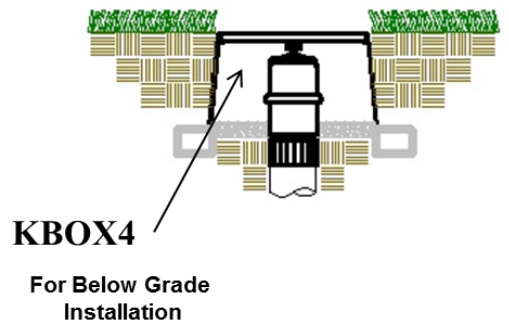
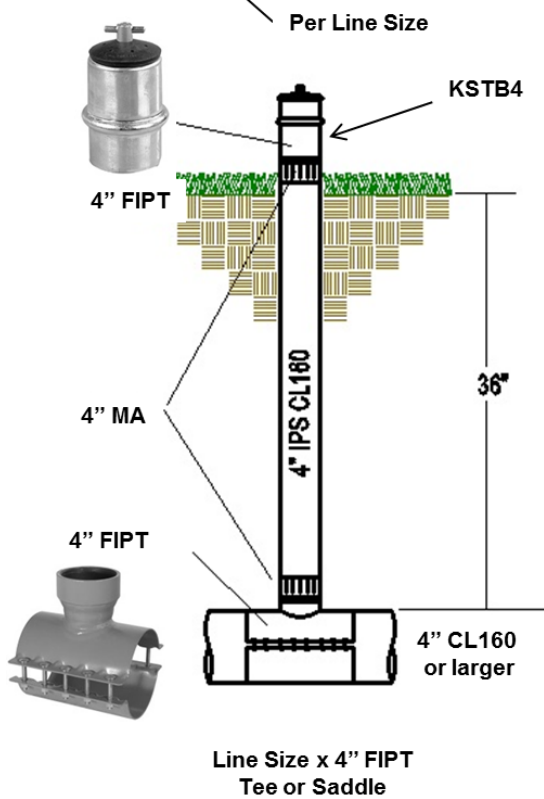

KSTB4

Details in Installation - For Water-Reel Models T23x600, T27x980, T30x660, T30x980, T30x1200 & T33x1120

KVOL4x4 Details

Isolation valve and French drain recommended for use in freezing temperatures.

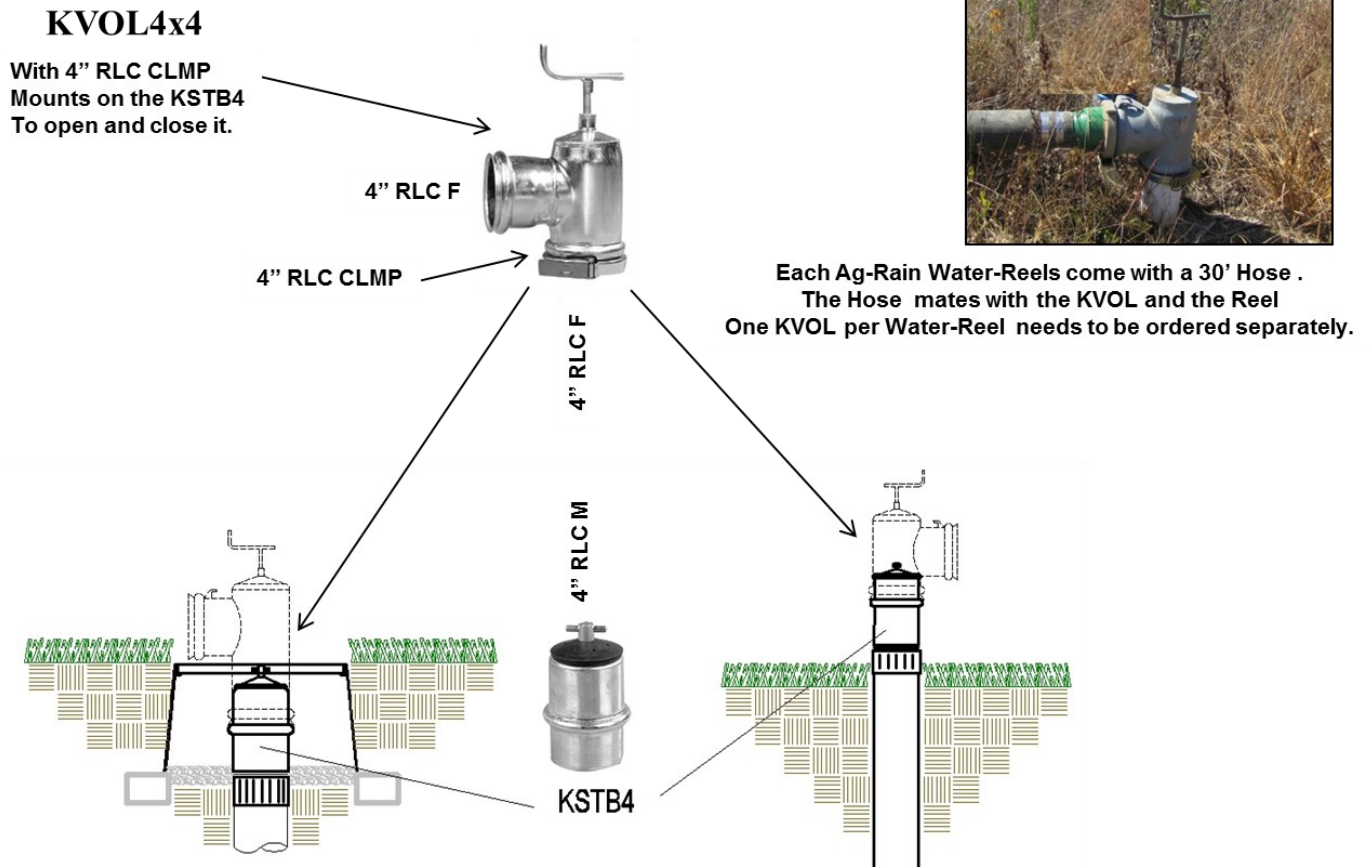

Details in Installation - For Water-Reel Models T37x1080, T37x1220, T40x1240, T40x1320, T41x1575, T45x1150, T45x1320

KSTB6 Details

Isolation valve and French drain recommended for use in freezing temperatures.

KSTB6x Assembly

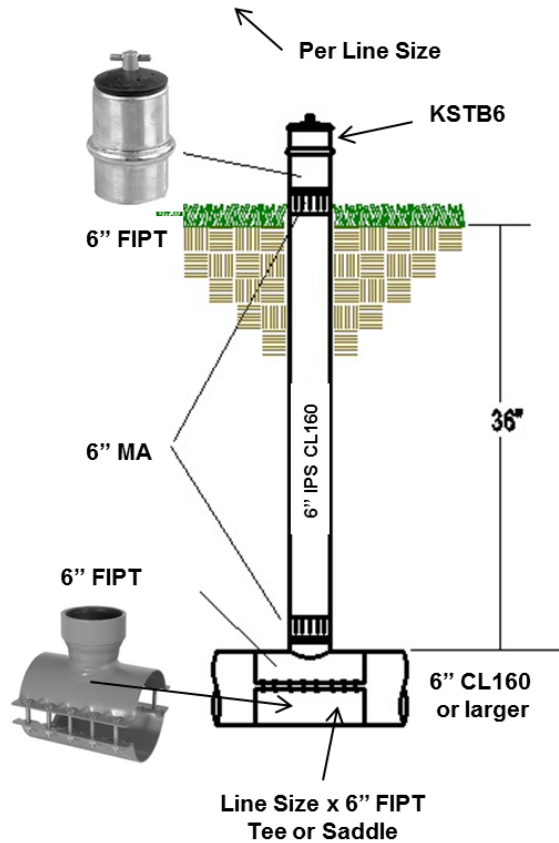

Options

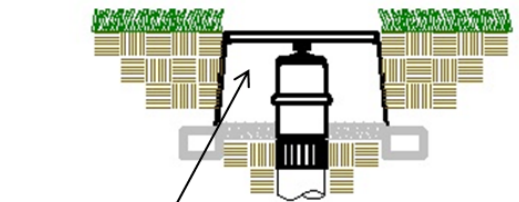

KBOX6

For Below Grade Installation

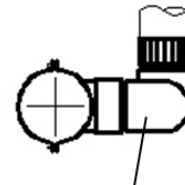

To reduce the possibility of mainline damage Rotate Tee (or Saddle) and use KSWNG6

KSWNG6x Per Line Size



KSTB6

Details in Installation

VOL6x4 Details

Isolation valve and French drain recommended for use in freezing temperatures.

KVOL6x4
With 6" RLC CLMP
Mounts on the KSTB6
To open and close it.

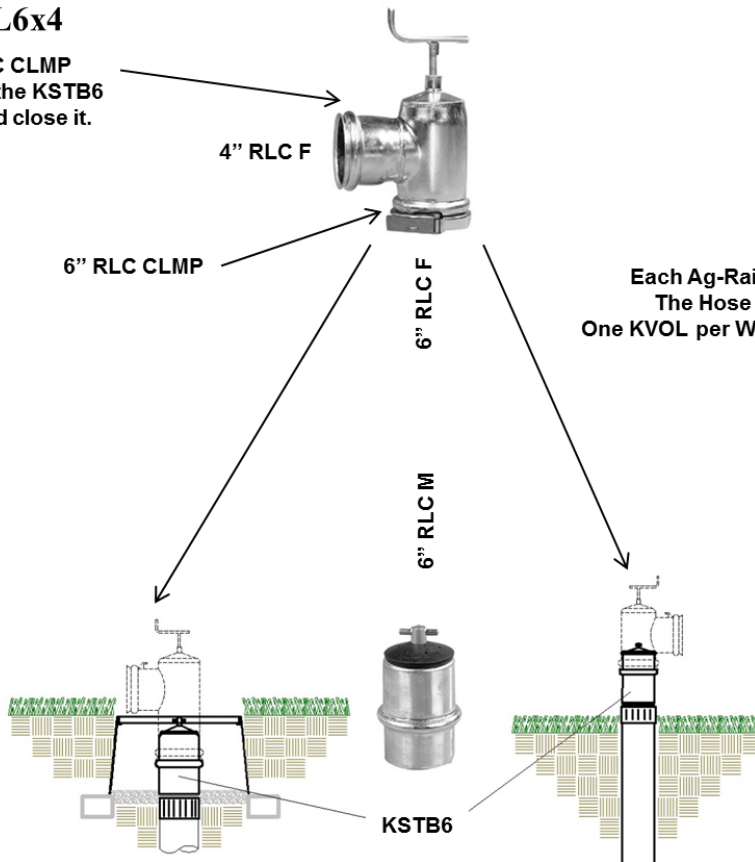

Each Ag-Rain Water-Reels come with a 30' Hose .
The Hose mates with the KVOL and the Reel
One KVOL per Water-Reel needs to be ordered separately.

Details in Installation

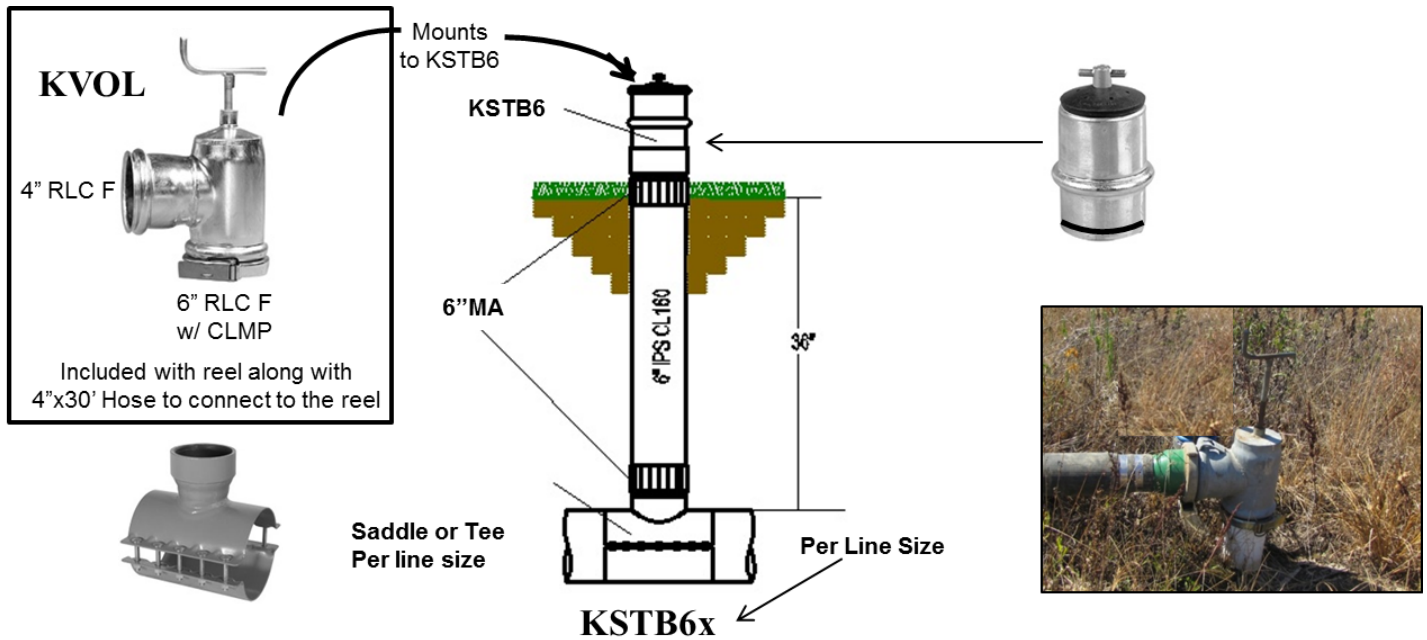

Field Assemblies	QTY	QTY	QTY	QTY	QTY	
	TTL	WA-N	WA-C	WA-S	EA	
KSTB6x06	3	3	0	0	0	Tee
KSTB6x08	41	10	5	12	14	Saddle
KSTB6x10	32	11	5	2	14	Saddle
KSTB6x12	8	2	6	0	0	Saddle
KSTB6x15	0	0	0	0	0	Saddle
Total	84	26	16	14	28	



Details in Installation

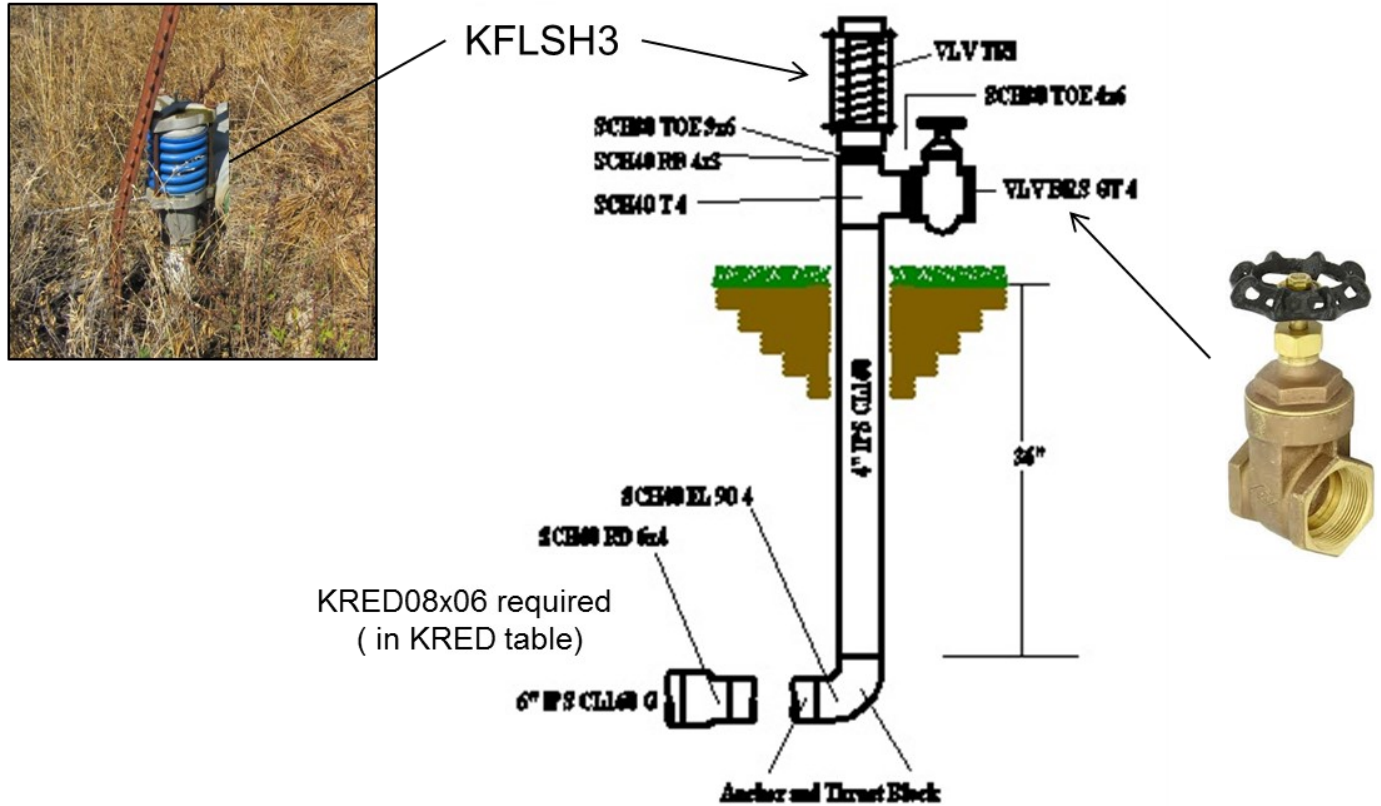

Field Assemblies	QTY	QTY	QTY	QTY	QTY
	TTL	WA-N	WA-C	WA-S	EA
KFLSH3x06	8	3	1	2	2

Details in Installation

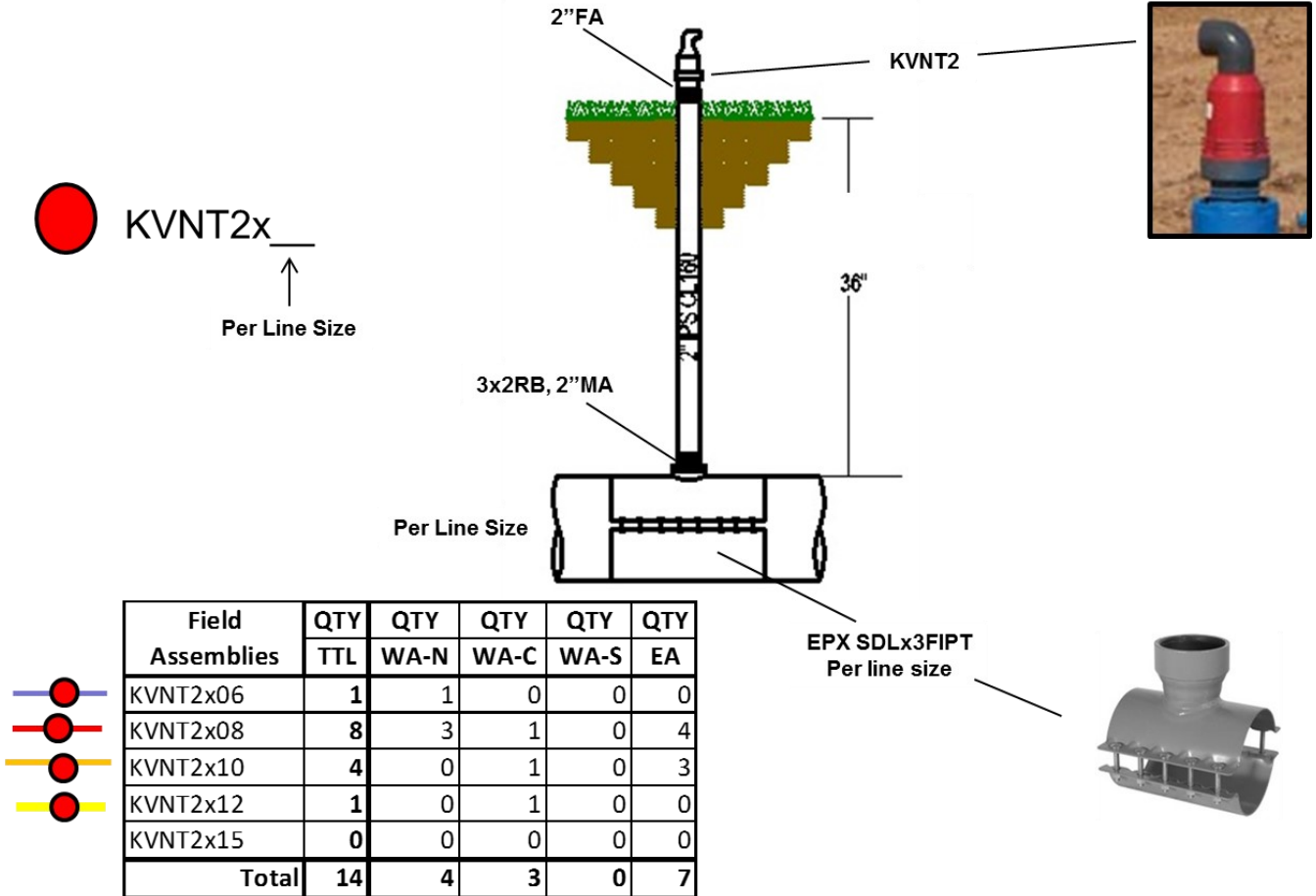

Details in Installation



KTAV



EPX SDLx3FIPT
Per line size

3"MA

3" IPS CL160

36"

Per line size

KTAV

Per Line Size

Field Assemblies	QTY	QTY	QTY	QTY	QTY
	TTL	WA-N	WA-C	WA-S	EA
KTAV06	0	0	0	0	0
KTAV08	0	0	0	0	0
KTAV10	5	3	0	2	0
KTAV12	4	1	1	0	2
KTAV15	0	0	0	0	0
Total	9	4	1	2	2

Details in Installation

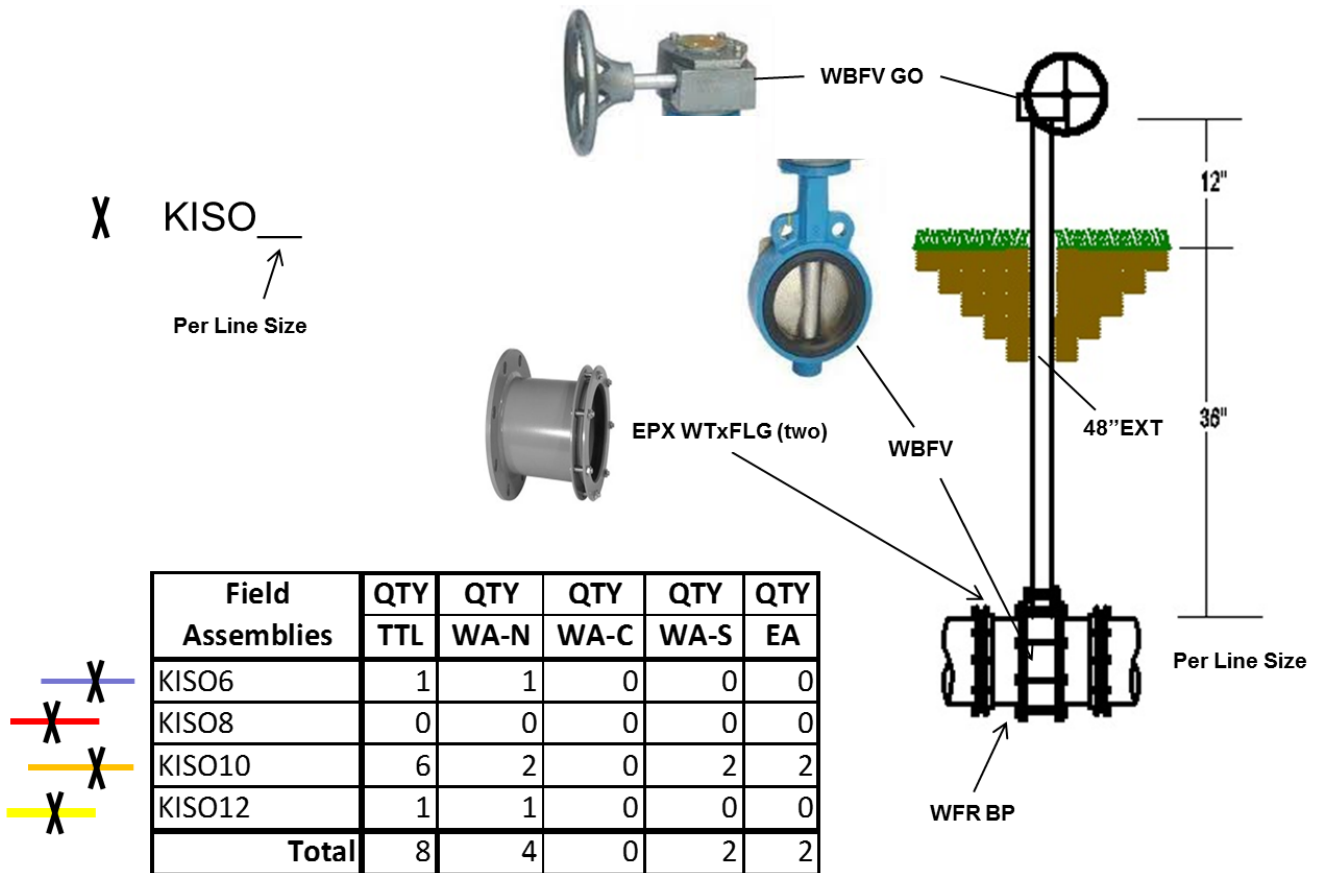

Details in Installation

Spare Repair Couplers

Field Assemblies	QTY
	TTL
KCPLG06	1
KCPLG08	3
KCPLG10	3
KCPLG12	2
KCPLG15	1
Sub-Total	10

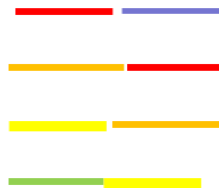

Field Assemblies	QTY TTL	QTY WA-N	QTY WA-C	QTY WA-S	QTY EA
KRED08x06	7	2	1	2	2
KRED10x08	8	3	1	2	2
KRED12x10	4	1	1	0	2
KRED15x12	0	0	0	0	0
Sub-Total	19				

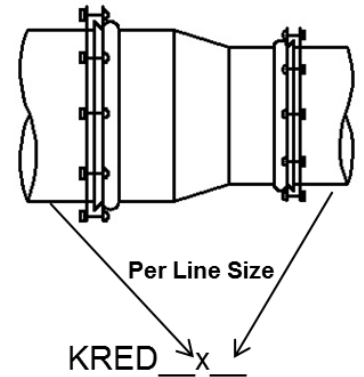

Details in Installation

Field Assemblies	QTY	QTY	QTY	QTY	QTY
	TTL	WA-N	WA-C	WA-S	EA
KT06	1	1	0	0	0
KT10	2	0	0	1	1
KT12	1	1			
KT15	0	0	0	0	0
KT15x06	0	0	0	0	0
Sub-total	4				



Field Assemblies	QTY	QTY	QTY	QTY	QTY
	TTL	WA-N	WA-C	WA-S	EA
KL90-08	1	0	0	0	1
KL90-10	2	1	1	0	0
KL90-12	5	1	2	1	1
KL90-15	0	0	0	0	0

Sub-Total 8

Field Assemblies	QTY	QTY	QTY	QTY	QTY
	TTL	WA-N	WA-C	WA-S	EA
KL22-06	1	1	0	0	0
KL22-08	0	0	0	0	0
KL22-10	3				3
KL45-08	0	0	0	0	0
KL45-10	4	0	0	0	4
Sub-Total	8				





Efficiency Tables

Net PET (in.day)	Cool Humid	Cool Dry	Warm Humid	Warm Dry	Hot Humid	Windy Hot Humid	Hot Arid	Windy Hot Arid
Max Yield	0.10	0.15	0.20	0.25	0.30	0.35	0.40	0.45
90% Yield	0.09	0.14	0.19	0.24	0.29	0.34	0.39	0.44
50% Yield	0.08	0.13	0.18	0.23	0.28	0.33	0.38	0.43
20% Yield	0.07	0.12	0.17	0.22	0.27	0.32	0.37	0.42
Sustain only	0.06	0.11	0.16	0.21	0.26	0.31	0.36	0.41

Decrease by reliable beneficial precipitation
in Peak Use frequency window divided by # of days in frequency

Efficiency (%)	Subsurface Dri	Surface Drip	Pivot	Water-Reel	Solid Set Perminate	Solid Set Temp	Surface
Well Managed	95%	90%	80%	80%	75%	70%	65%
Managed	90%	85%	75%	75%	70%	65%	60%
Poorly Managed	80%	75%	70%	72%	65%	60%	55%
Not Managed	65%	65%	65%	65%	60%	55%	50%

Devide Net PET by Efficiency to get Gross PET

Crop	Factor @ PET	Crop	Factor @ PET	Crop	Factor @ PET
Safflower	1.2	Coffee	0.9	Castor beans	0.8
Potatoes	1.2	Tea	0.9	guar	0.8
Sweet Corn	1.2	peas	0.9	cotton	0.8
Barley	1.1	Almonds	0.9	Flax	0.8
Cantalope	1.1	Apples	0.9	Sugar Beets	0.8
Surgum	1.1	Apricots	0.9	Grapes	0.7
Wheat	1.1	Bananas	0.9	Soybean	0.7
Berries	1.1	Cherries	0.9	Citrus	0.6
onions dry	1.1	Peaches	0.9	Broccoli	0.6
Sugar Cane	1.1	Pears	0.9	Cabbage	0.6
Alfalfa	1.0	Pecans	0.9	Carrots	0.6
Pumpkin	1.0	Plums	0.9	Cauliflower	0.6
sesbania	1.0	Strawberries	0.9	Onions Green	0.6
Turf Grass	1.0	Walnuts	0.9	Lettus	0.4
Bermuda Grass	0.9	Blue Panic Grass	0.8	non production pasture	0.3

$$\text{Design PET (design depth)} = (\text{Net PET (reference PET)} \times \text{Crop Factor}) \div \text{Efficiency}$$

Less beneficial precipitation



Common Water Reel Applications with Suggested Models

Efficiency Tables

Design PET			Operating Hours per Day									
Gross Application			22	20	18	16	14	12	10	8	6	
in/day	in/wk	in/2 wks	gpm/ac	gpm/ac	gpm/ac	gpm/ac	gpm/ac	gpm/ac	gpm/ac	gpm/ac	gpm/ac	
0.02	0.14	0.28	0.41	0.45	0.50	0.57	0.65	0.75	0.91	1.13	1.51	
0.04	0.28	0.56	0.82	0.91	1.01	1.13	1.29	1.51	1.81	2.26	3.02	
0.04	0.28	0.56	0.82	0.91	1.01	1.13	1.29	1.51	1.81	2.26	3.02	
0.06	0.42	0.84	1.23	1.36	1.51	1.70	1.94	2.26	2.72	3.39	4.53	
0.08	0.56	1.12	1.65	1.81	2.01	2.26	2.59	3.02	3.62	4.53	6.03	
0.10	0.7	1.4	2.06	2.26	2.51	2.83	3.23	3.77	4.53	5.66	7.54	
0.12	0.84	1.68	2.47	2.72	3.02	3.39	3.88	4.53	5.43	6.79	9.05	
0.14	0.98	1.96	2.88	3.17	3.52	3.96	4.53	5.28	6.34	7.92	10.56	
0.16	1.12	2.24	3.29	3.62	4.02	4.53	5.17	6.03	7.24	9.05	12.07	
0.18	1.26	2.52	3.70	4.07	4.53	5.09	5.82	6.79	8.15	10.18	13.58	
0.20	1.4	2.8	4.11	4.53	5.03	5.66	6.46	7.54	9.05	11.31	15.08	
0.22	1.54	3.08	4.53	4.98	5.53	6.22	7.11	8.30	9.96	12.44	16.59	
0.24	1.68	3.36	4.94	5.43	6.03	6.79	7.76	9.05	10.86	13.58	18.10	
0.26	1.82	3.64	5.35	5.88	6.54	7.35	8.40	9.80	11.77	14.71	19.61	
0.28	1.96	3.92	5.76	6.34	7.04	7.92	9.05	10.56	12.67	15.84	21.12	
0.30	2.1	4.2	6.17	6.79	7.54	8.48	9.70	11.31	13.58	16.97	22.63	
0.32	2.24	4.48	6.58	7.24	8.04	9.05	10.34	12.07	14.48	18.10	24.13	
0.34	2.38	4.76	6.99	7.69	8.55	9.62	10.99	12.82	15.39	19.23	25.64	
0.36	2.52	5.04	7.40	8.15	9.05	10.18	11.64	13.58	16.29	20.36	27.15	
0.38	2.66	5.32	7.82	8.60	9.55	10.75	12.28	14.33	17.20	21.49	28.66	
0.40	2.8	5.6	8.23	9.05	10.06	11.31	12.93	15.08	18.10	22.63	30.17	
0.42	2.94	5.88	8.64	9.50	10.56	11.88	13.58	15.84	19.01	23.76	31.68	
0.44	3.08	6.16	9.05	9.96	11.06	12.44	14.22	16.59	19.91	24.89	33.18	
0.46	3.22	6.44	9.46	10.41	11.56	13.01	14.87	17.35	20.82	26.02	34.69	
0.48	3.36	6.72	9.87	10.86	12.07	13.58	15.51	18.10	21.72	27.15	36.20	
0.50	3.5	7	10.28	11.31	12.57	14.14	16.16	18.85	22.63	28.28	37.71	

Enter the left side of chart a the calculated Design PET

Follow the row to the right to the column noting the operating hours available read the gpm/ac at the intersection.

Multiply this value by the total number of acres to be irrigated to get required system flow.

If you have a know flow and you wish to determine the number of acres you can irrigate.

Divide the flow by the gpm/ac to determine the number of acres that can be irrigated.ame value

If you have a know flow and acreage and wish to determine how much water can be applied,

Devide the flow by the acres. Enter the chart at the available operating hours column.

Follow it down until you finde the gpm/ac value calculated.

Read the resulting application on the left side of that row.

Efficiency Tables

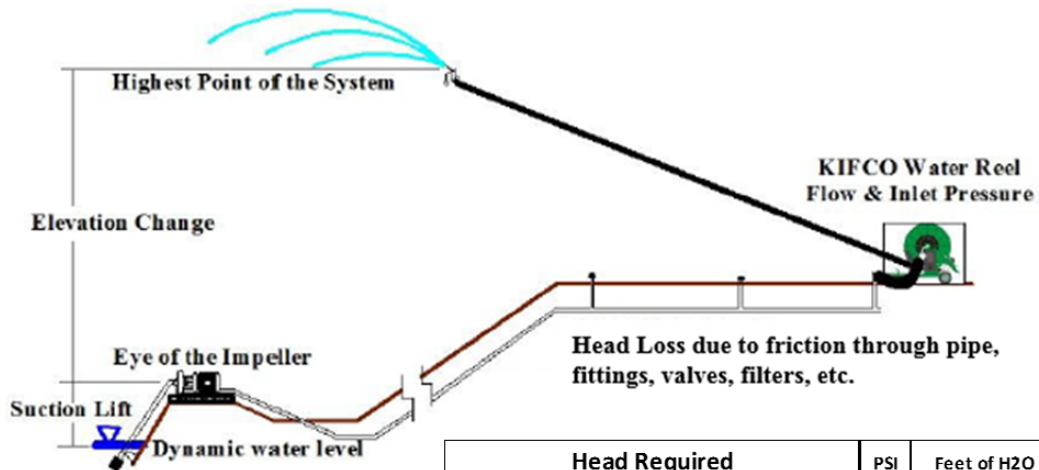

$$HP = (TDH \times Q) \div (EFF \times 3960)$$

HP = Horse Power
Required at pump shaft

TDH = Total Dynamic Head
in ft of H₂O

Q = Total system flow in GPM

Head Required	PSI	Feet of H ₂ O
Water-Reel inlet pressure		
Turbine Loss		
HPSV Loss		
Elevation gain or Loss		
Lift gain or loss		
Head loss due to flow through pipe		
Headloss due to fittings		
Head loss due to screens and filters		
Head loss due to valves, etc.		
TDH		

EFF = Pump efficiency at this performance point

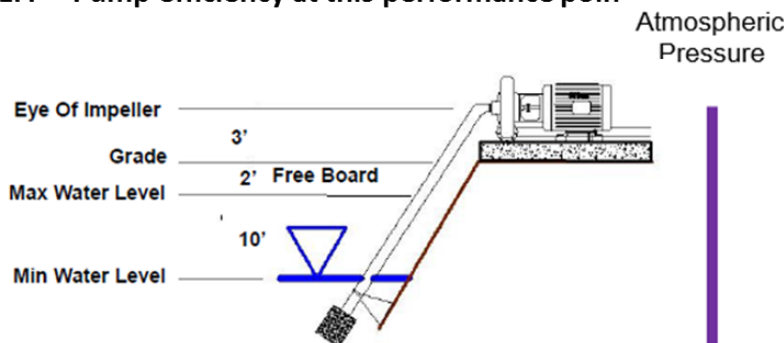

	PSI	Feet of Water
Lift		
Entrance Loss		
Exit Loss		
Fitting Loss		
Filter /screen Loss		
Head loss through Pipe		
NPSH Losses		

Elevation ABSL (ft)	Pressure (PSI)	Pressure Ft of H ₂ O
0	14.7	33.9
500	14.43	33.3
1000	14.17	32.7
1500	13.91	32.1
2000	13.66	31.5
2500	13.41	31.0
3000	13.17	30.4
3500	12.93	29.9
4000	12.69	29.3
4500	12.46	28.8
5000	12.23	28.2
5500	12	27.7
6000	11.77	27.2
6500	11.55	26.7
7000	11.34	26.2
7500	11.13	25.7
8000	10.91	25.2
8500	10.71	24.7
9000	10.5	24.2
9500	10.3	23.8
10000	10.1	23.3
10500	9.91	22.9
11000	9.72	22.4
11500	9.53	22.0
12000	9.34	21.6
12500	9.16	21.2
13000	8.99	20.8
13500	8.81	20.3
14000	8.63	19.9
14500	8.46	19.5
15000	8.29	19.1



Efficiency Tables

BHP = Horse Power Required at the Pump Shaft

CHP = Continuous Horse Power provided by the drive engine or electric motor

IHP = Intermittent Horse Power of drive engine or electric motor

Engine CHP < IHP, The relationship between CHP & IHP is not constant.

Increase BHP by the transfer loss percentage below.

Power plants for Irrigation Pumps should be sized using CHP not IHP

CHP should be provided by MFG as per standard testing.

Published engine CHP typically need to be derated for:

Accessories: - 10 % w/o fan, -15% w fan

Elevation: -3% per 1000' > 3000' ABSL for non-turbo; 0% for engine with turbo

Temperature: -1% per 10 °F > 85 °F w Turbo; -1% per 5 °F > 85°F wo Turbo

All horsepowers should be at the required RPM

Transfer Loss	
SAE Couple	1.0%
Close Coupled	0.5%
Frame & Coupling	2.0%
PTO	3.0%
Belts & Pulleys	3-7%
VHS Motor	0.5%
RAG	3.0%
Extended PTO shaft	+
Vertical Shaft	+

+ Consult MFG

The drive Engine (or motor) CHP after de-rating should be greater than the BHP plus transfer loss.



Specifying Water-Reels: Consumptive Use Method

To size a machine inquire what depth of water is to be applied and how many hours a day they will run. Use the corresponding gpm/acre figure multiplied by the total acres to determine the required flow. If the referenced depth used was a net value, divide by the efficiency. If the crop has a crop factor other than one, multiply by the crop factor. It is important to discuss operating hours with the client. Flow rate and capital cost of the system increase dramatically with a decrease in operating hours.

PET Crop Factor = 1			Operating Hours per Day								
Gross ET			22	20	18	16	14	12	10	8	6
in/day	in/wk	in/2 wks	gpm/ac	gpm/ac	gpm/ac	gpm/ac	gpm/ac	gpm/ac	gpm/ac	gpm/ac	gpm/ac
0.02	0.14	0.28	0.41	0.45	0.50	0.57	0.65	0.75	0.91	1.13	1.51
0.04	0.28	0.56	0.82	0.91	1.01	1.13	1.29	1.51	1.81	2.26	3.02
0.04	0.28	0.56	0.82	0.91	1.01	1.13	1.29	1.51	1.81	2.26	3.02
0.06	0.42	0.84	1.23	1.36	1.51	1.70	1.94	2.26	2.72	3.39	4.53
0.08	0.56	1.12	1.65	1.81	2.01	2.26	2.59	3.02	3.62	4.53	6.03
0.10	0.7	1.4	2.06	2.26	2.51	2.83	3.23	3.77	4.53	5.66	7.54
0.12	0.84	1.68	2.47	2.72	3.02	3.39	3.88	4.53	5.43	6.79	9.05
0.14	0.98	1.96	2.88	3.17	3.52	3.96	4.53	5.28	6.34	7.92	10.56
0.16	1.12	2.24	3.29	3.62	4.02	4.53	5.17	6.03	7.24	9.05	12.07
0.18	1.26	2.52	3.70	4.07	4.53	5.09	5.82	6.79	8.15	10.18	13.58
0.20	1.4	2.8	4.11	4.53	5.03	5.66	6.46	7.54	9.05	11.31	15.08
0.22	1.54	3.08	4.53	4.98	5.53	6.22	7.11	8.30	9.96	12.44	16.59
0.24	1.68	3.36	4.94	5.43	6.03	6.79	7.76	9.05	10.86	13.58	18.10
0.26	1.82	3.64	5.35	5.88	6.54	7.35	8.40	9.80	11.77	14.71	19.61
0.28	1.96	3.92	5.76	6.34	7.04	7.92	9.05	10.56	12.67	15.84	21.12
0.30	2.1	4.2	6.17	6.79	7.54	8.48	9.70	11.31	13.58	16.97	22.63
0.32	2.24	4.48	6.58	7.24	8.04	9.05	10.34	12.07	14.48	18.10	24.13
0.34	2.38	4.76	6.99	7.69	8.55	9.62	10.99	12.82	15.39	19.23	25.64
0.36	2.52	5.04	7.40	8.15	9.05	10.18	11.64	13.58	16.29	20.36	27.15
0.38	2.66	5.32	7.82	8.60	9.55	10.75	12.28	14.33	17.20	21.49	28.66
0.40	2.8	5.6	8.23	9.05	10.06	11.31	12.93	15.08	18.10	22.63	30.17
0.42	2.94	5.88	8.64	9.50	10.56	11.88	13.58	15.84	19.01	23.76	31.68
0.44	3.08	6.16	9.05	9.96	11.06	12.44	14.22	16.59	19.91	24.89	33.18
0.46	3.22	6.44	9.46	10.41	11.56	13.01	14.87	17.35	20.82	26.02	34.69
0.48	3.36	6.72	9.87	10.86	12.07	13.58	15.51	18.10	21.72	27.15	36.20
0.50	3.5	7	10.28	11.31	12.57	14.14	16.16	18.85	22.63	28.28	37.71

Sometimes the term Supplemental Watering is used to justify values below the calculated required flow. In this case the producer should be advised without precipitation the system cannot sustain production.



Metric to US Conversions

- Millimeters (mm) x 0.03937 = inches (") (in)
- Centimeters (cm) x 0.3937 = inches (") (in)
- Meters (m) x 39.37 = inches (") (in)
- Meters (m) x 3.281 = feet (') (ft)
- Meters (m) x 1.094 = yards (yds)
- Kilometers (km) x 0.62137 = miles (mi)
- Kilometers (km) x 3280.87 = feet (') (ft)
- Liters (l) x 0.2642 = gallons (U.S.) (gals)
- Liters (l) x 0.0353 = cubic feet
- Bars x 14.5038 = pounds per square inch (PSI)
- Kilograms (kg) x 2.205 = Pounds (P)
- Kilometers (km) x 1093.62 = yards (yds)
- Square centimeters x 0.155 = square inches
- Square meters x 10.76 = square feet
- Square kilometers x 0.386 = square miles
- Cubic centimeters x 0.06102 = cubic inches
- Cubic meters x 35.315 = cubic feet

US to Metric Conversions

- Inches (") (in) x 25.4 = millimeters (mm)
- Inches (") (in) x 2.54 = centimeters (cm)
- Inches (") (in) x 0.0254 = meters (m)
- Feet (') (ft) x 0.3048 = meters (m)
- Yards (yds) x 0.9144 = meters (m)
- Miles (mi) x 1.6093 = kilometers (km)
- One mile = 5,280 feet (ft)
- Feet (') (ft) x 0.0003048 = kilometers (km)
- Gallons (gals) x 3.78 = liters (l)
- Cubic feet x 28.316 = liters (l)
- Pounds (P) x 0.4536 = kilograms (kg)
- Square inches x 6.452 = square centimeters
- Square feet x 0.0929 = square meters
- Square miles x 2.59 = square kilometers
- Acres x 4046.85 = square meters
- Cubic inches x 16.39 = cubic centimeters
- Cubic feet x 0.0283 = cubic meters

Useful Irrigation Formulas

Water Measurement

- 1 cubic foot = 7.48 gallons = 62.4 pounds of water
- 1 acre-foot = 43,560 cubic feet = 325,851 gallons = 12 acre-inches
- 1 acre-foot covers 1 acre of land 1 foot deep; 1 acre-inch = 27,154 gallons
- 1 cubic meter = 1,000 liters = 264.18 gallons
- 1 acre-inch = 450 gallons per minute (GPM)
- 1 gallon = 128 ounces = 3,785 milliliters = 8.33 pounds
- 1 pound = 454 grams



Useful Irrigation Formulas Continued:

Water Measurement

- 1 cubic foot = 7.48 gallons = 62.4 pounds of water
 - 1 acre-foot = 43,560 cubic feet = 325,851 gallons = 12 acre-inches
 - 1 acre-foot covers 1 acre of land 1 foot deep; 1 acre-inch = 27,154 gallons
 - 1 cubic meter = 1,000 liters = 264.18 gallons
- 1 acre-inch = 450 gallons per minute (GPM)
 hour or 1 cubic foot per second (cfs)
- 1 gallon = 128 ounces = 3,785 milliliters = 8.33 pounds
- 1 pound = 454 grams

Pressure

- 1 pound per square inch (psi) = 2.31
 - Feet of head x .433 = psi
- A column of water 2.31 feet deep exerts a pressure of 1 psi
 feet of head = psi x 2.31
- Total Dynamic Head (TDH) includes: Pumping Lift, Elevation Change, Friction Loss and Irrigation System Operating Pressure
- TDH = Lift + Elevation + Friction + System Pressure

Area/Length

1 acre = 0.405 hectare (ha) = 43,560 feet²

Horsepower

Water Horsepower (WHP) – power required to lift a given quantity of water against a given total dynamic head

$$WHP = \frac{Q \times H}{3,960}$$

where: Q = flow rate, GPM
 H = total dynamic head, feet

Brake Horsepower (BHP) – required power input at the pump

$$BHP = \frac{WHP}{E}$$

where: E = pump efficiency

Power Unit Horsepower

Electric Units: approximate name plate horsepower = BHP



Useful Irrigation Formulas Continued:

Internal combustion units:

- 20% for continuous duty
- 5% for right-angle drive
- 3% for each 1,000 feet above sea level
- 1% for each 10° above 60°F

Approximate Engine

$$\text{Horsepower Required} = \frac{\text{BHP}}{0.80 \times 0.95 \times 0.91 \times 0.96}$$

cont. drive 3,000' 100°F elevation

Nebraska Performance Criteria (NPC)

<u>Energy source</u>	<u>WHP-hours per unit of fuel</u>
Diesel	12.5 WHP-hrs per gallon
Propane	6.89 WHP-hrs per gallon
Natural Gas:	
925 BTU/ft ³	61.7 WHP-hrs per 1,000 ft ³ (MCF)
1,000 BTU/ft ³	66.7 WHP-hrs per 1,000 ft ³ (MCF)
Electric	0.885 WHP-hrs per kilowatt-hour

Water Application

$$\text{Average Application (inches)} = \frac{Q \cdot T}{A}$$

- Where: Q = Flow Rate, Acre-Inches/Hour or GPM/450
- T = Length of Application, Hours
- A = Area Irrigated, Acres

Set Size (Acres) is computed by the formula:

$$\frac{\text{No. of Rows} \times \text{Width of Row (Feet)} \times \text{Length of Run (Feet)}}{43,560 \text{ Feet}^2/\text{Acre}}$$

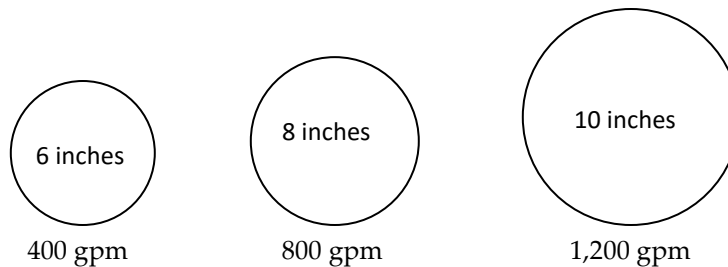



Most Trusted Traveling Irrigation Systems Since 1964

Wastewater Friction Loss In Pipelines

The information contained in this bulletin gives a guide to the additional friction loss of water in pipelines due to solids content up to 6%

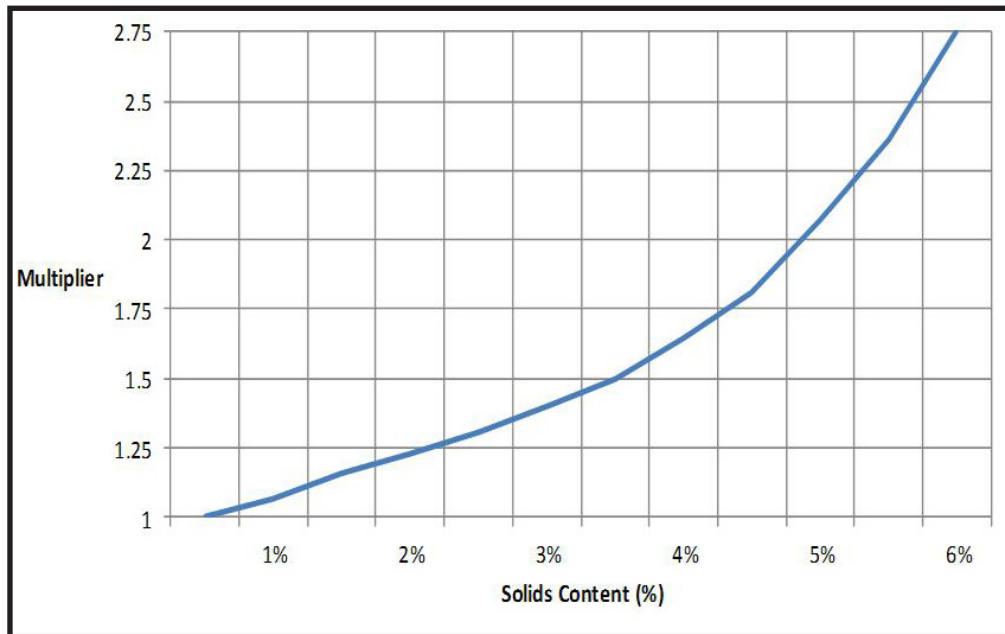

To Find Wastewater Friction Loss:

1. Calculate the standard friction loss for water.
2. Establish the solids content of wastewater.
3. Find the multiplier from graph above.
4. Friction loss for water x multiplier = wastewater friction loss.

Guide To Flow Characteristics

