



E210L

MOST TRUSTED TRAVELING IRRIGATION SYSTEMS SINCE 1964

Kifco Water-Reels offer simple and reliable irrigation solutions. The NEW E210L is a one of a kind, American made traveler featuring a roller bearing turntable that allows for 180 degree rotation to irrigate in the opposite direction. The E210L's 3 wheel design can easily be towed around with your ATV or utility vehicle without the heavy tongue weight, eliminating the need for a dedicated tractor to deploy it. Kifco offers industry leading products with service and distribution through our many Kifco Authorized Independent Dealers throughout the United States.

Perfect Size

The E210L features 2.1" ID x 850' American made MDPE tube and a three-wheeled chassis with large flotation tires and easy to use crank jack stabilizer legs for stability. Fork pockets are built into the frame making loading and unloading this unit a breeze. With the same rugged and reliable construction that Kifco has included in our equipment since 1964, the E210L features automatic shutoff for unattended operation, a mechanical levelwind system to prevent kinking and mis-wraps for uniform tube rewinding, and a sprinkler selection valve which easily allows for automatic sprinkler shutoff at the end of the run.

Drive System

The Kifco Model E210L uses a 4Hp gas engine to retract the sprinkler cart. Engine drives consume zero pressure and are capable of handling water supplies that contain solids. The E210L operates as low as 52 psi and 51 gpm and features simple and accurate speed control.

American Made Advantage

Proudly made in the USA, you can rely on a quality product with easy access to repair parts when you need them.

Available Options:

The following options are available for this model:

Sprinklers - Komet TwinMax or Nelson SR75 (full sprinkler performance on next page)

Booster Pump - 9HP Gas

Primary Pumps - 21HP Gas, 23HP Gas or 37HP Gas



Model E210L Technical Specifications

Tube Inner Diameter/Length
2.1" x 850'

Irrigated Width
142' - 210'

Irrigated Length
921' - 955'

Irrigated Area Per Run
3.0 to 4.6 Acres

GPM Range
51 - 123

Inlet PSI Range
52 - 138

Hours Per Full Run
11.6 - 24

Retraction Speed
35.5 - 73 feet per hour

Inlet Diameter
2" Male Camlock

Supply Hoses Included
(2) 15' Supply Hose with
2" Male x Female Camlock

Dry Weight
2,385 lbs.

Weight with Water
3,755 lbs.

Chassis Size
T6

The Kifco E210L Water-Reel®

Sprinkler Options & Performance

Sprinkler Model	Nozzle Dia.	Inlet PSI	(Q) GPM	Width (ft.) (80%)	Length (ft.) (80%)	Wetted Dia. (ft.)	Application Rate (in.)
Komet Twin Max	0.55"	52	51	149	924	186	0.3 - 1.4
	0.55"	118	78	201	950	251	0.3 - 1.4
	0.63"	64	67	160	930	200	0.3 - 1.6
	0.63"	125	95	206	953	257	0.4 - 1.6
	0.67"	71	76	164	932	205	0.4 - 1.6
	0.67"	129	103	208	954	260	0.4 - 1.6
	0.71"	80	85	167	934	209	0.4 - 1.6
	0.71"	133	111	210	955	263	0.4 - 1.6
	0.79"	101	105	167	934	209	0.6 - 1.6
0.79"	128	119	201	950	251	0.6 - 1.6	
Nelson SR75	0.60"	58	59	142	921	178	0.3 - 1.4
	0.60"	128	98	186	943	232	0.4 - 1.6
	0.65"	65	69	142	921	178	0.4 - 1.6
	0.65"	128	89	195	948	244	0.4 - 1.6
	0.70"	76	81	157	928	196	0.4 - 1.6
	0.70"	135	109	198	949	248	0.4 - 1.6
	0.75"	87	93	162	931	202	0.6 - 1.6
	0.75"	133	115	192	946	240	0.6 - 1.6
	0.80"	102	106	166	933	208	0.6 - 1.6
0.80"	138	123	190	945	238	0.6 - 1.6	

Area covered may vary depending on wind conditions, and use of different sprinklers. Specifications are subject to change without notice. Technical specifications contained herein are based upon sprinkler manufacturer's recommended pressure and flow. Actual specifications may vary.

Rotate Turntable 180° and Irrigate in Opposite Direction

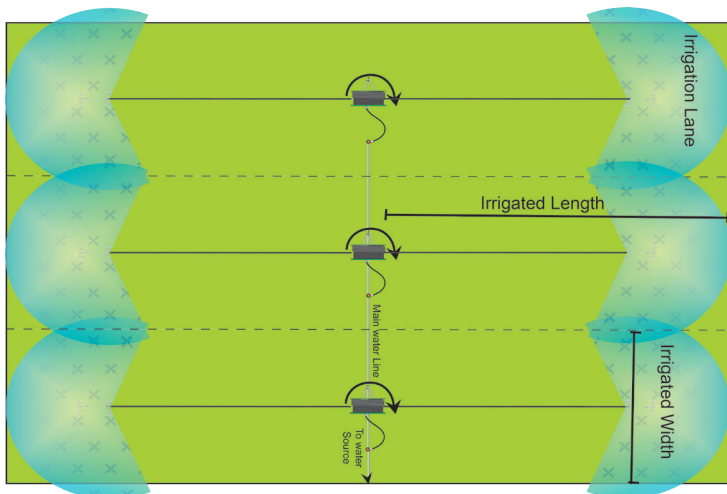

Most Trusted Traveling Irrigation Systems Since 1964

Dimensions

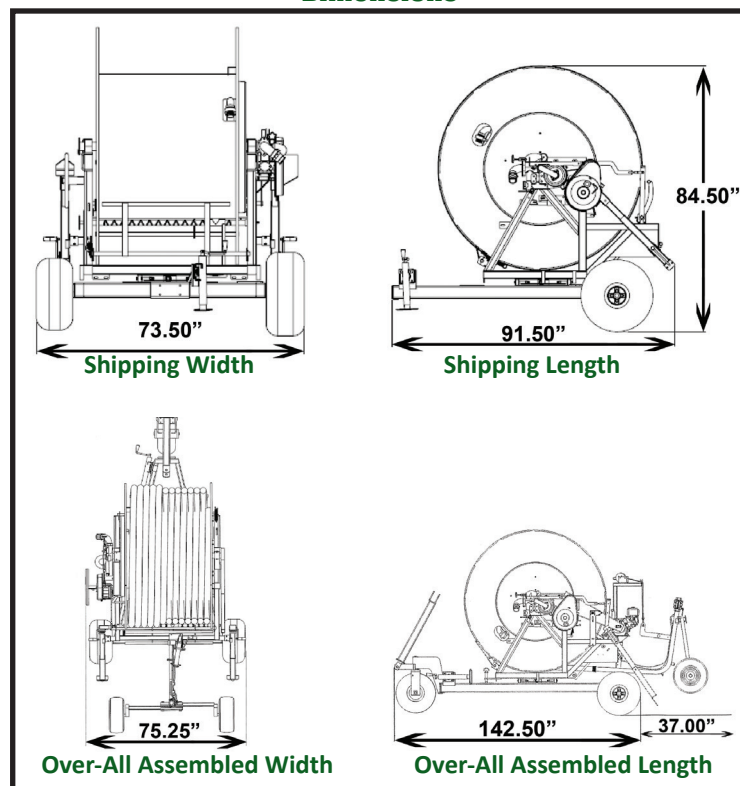

Standard Connection

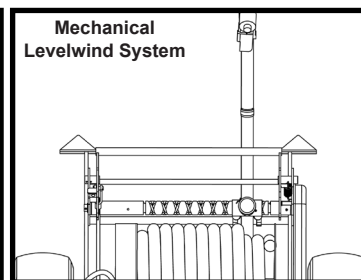
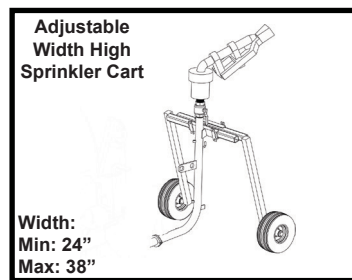
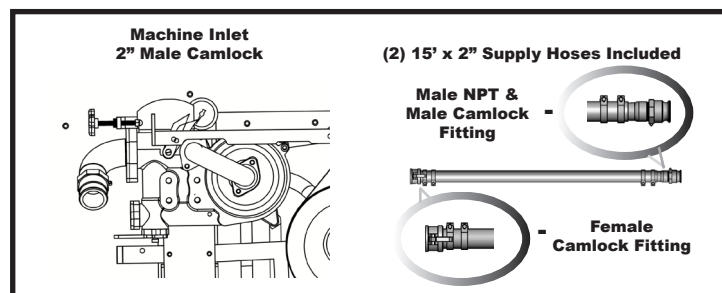

Common Applications For Model E210L



Hobby Farms, Ranches & Pastures



Agriculture & Sod Production