



REVOLVING TRUCK INTERNAL HALYARD STAINLESS STEEL-WINCH FLAGPOLES

FOR QUICK AND PROFESSIONAL COMMERCIAL INSTALLATION READ ALL INSTRUCTIONS BEFORE PROCEEDING

GROUND SLEEVE INSTALLATION:

STEP 1 - Following the dimensions found on the back page “Foundation Dimension” sheet, dig your hole. You may want to call your local utilities locator office to make sure you have no underground utilities or sprinkler lines in the spot where you are installing your flagpole.

STEP 2 – Set your ground sleeve in the center of your pre dug hole making sure it sets level. Make sure that the bottom spike is secured in the ground to help steady the sleeve. Make sure the top of your sleeve sets 1” above the finished grade.

STEP 3 – Using 3000 PSI cement (pre mixed or bagged quick set post mix), pour cement into hole around sleeve. Fill about 1/3 of the way and check the plumb of your sleeve with a level. Continue to fill the hole, checking for plumb as you go. When you reach your finished grade smooth the concrete for a nice finish and check for final plumb.

We recommend that you let the ground sleeve set for at least 24 hours before standing your flagpole so that the cement can set up. **However, you can set your ground sleeve and stand your pole on the same day if you let the cement set up at least 24 hours before you place your flag on your flagpole. Be sure to use the quick set post mix concrete.** While you are attaching all of the hardware to your pole the cement will set up enough (if it is not too wet).

FLAGPOLE INSTALLATION:

STEP 4 – Lay out unwrapped pole on cribbing or other support on ground. If flagpole is in two sections, carefully lay out sections so that the identifying markings (letters/numbers) on the top of the bottom section and the bottom of the top section line up. These markings will need to be lined up for the sections to fit together properly. If you have more than one 2pc flagpole **do not mix up the sections**. Slide sections together until they become tight. You may use a small amount of liquid dish soap to help slip the joint together. You may need to place a wood block at the bottom of the flagpole and with a sledge hammer gently knock the pieces together until the joint comes together. There is a manufacturer’s acceptable range of 1” to 1-1/4” gap at the joint. If you do have a small gap and cannot get the joint any closer it is ok, your flagpole sections will not separate.

STEP 5 – Identify all parts and place them along the pole according to the diagram.

STEP 6 –Open the truck (B) by removing the screws. Feed the taped end of the cable (H) through the brass fitting on the base of the truck, up over the inside pulley then down through the threaded stem of the truck. Pull the cable until the stopper ball (I) at the other end of the cable stops at the brass fitting at the base of the truck. Put the top back on the truck and secure with screws. Feed a fish tape through the winch door opening to the top of the pole. Attach the fish tape to the end of the cable and carefully pull the fish tape back down the pole feeding the cable down inside the pole and out the winch door opening. Carefully thread the truck into the top of the flagpole being very careful not to pinch the cable while doing so. Using a pipe wrench tighten the threads. A loc-tite type product may be used in this process.

STEP 7 – Carefully screw the gold ball (A) spindle into the top of the truck. **DO NOT GRIP THE BALL TO TIGHTEN, GRIP SPINDLE/ROD.** Tighten all nuts and screws. Do not over tighten. A loc-tite type product may be used on all connections.

STEP 8 – Carefully pull the outside cable with the swivel on the end down to the winch door opening. Make sure that the remaining cable coming out of the winch door opening stays on the outside of the pole. As an added safety measure secure a small rope or twine the length of the flagpole to the swivel end of the cable. If the cable should come loose and slide to the top of the pole you will be able to bring it back down using this small rope or twine.

STEP 9 – If you are using a flash collar (G), gently slide the collar onto the butt end of the flagpole and up to just below the winch door opening. To secure it in place take the inside cable and wrap it around the collar a few times to hold it in place then feed the end of the cable through the swivel and coil the cable into a bundle and secure the ends with electrical tape so that the collar and both ends of cable are secure and will stay in place when the pole is stood.

STEP 10 – Stand the flagpole in the ground sleeve that was previously cemented into place. Center the pole inside the sleeve. Be careful when lifting the flagpole that you do so with a partner or crane to safely lift it into the ground sleeve. Have a couple of people hold the flagpole plumb with a level, wood shims may also be used, they are optional and not provided with the flagpole. Then another person will begin to fill the space around the pole with **DRY** sand. Be sure to use sand with very little or no silica so it will pack tight. Fill about 1/3 of the way and check for plumb with your level on two sides of the pole. Gently tap pole with a rubber mallet to help the sand settle. Keep adding sand and checking for plumb often as you go making adjustments as needed. If you use wood shims you can remove them or leave them in the sand. Fill sand to about 1/4” to 1/2” from the top of the ground sleeve.

STEP 11 – Using a clear silicone or self leveling cement sealant, cover the sand to seal out moisture. Silicone or sealant should completely cover all of the sand. Smooth sealant with trowel.

STEP 12 – Once pole is standing and plumb, remove electrical tape from your cable bundle. Be sure to hold both ends of the cable and gently slide the collar down to the bottom of the flagpole. Have one person hold the outside cable and another take the inside cable. With winch (K) in hand, insert the end of the inside cable into the winch cable hole. Once inserted secure cable end by tightening allen screw down against cable pinching it into place and holding it there securely. Once inserted and fastened, slide winch into the door opening and bolt winch onto the base plate welded inside the pole. As you insert the winch grasp the swivel end of the cable and pull cable down on the outside of pole applying gentle tension on the cable as the winch is being inserted into the winch hole. This will help prevent the cable from getting pinched or twisted inside the pole. The winch handle will later be inserted into the winch through the small hole drilled on the side of the pole.

STEP 13 – Attach the quick link (E) to the swivel end of cable. Attach the flag arrangement and (1) snap hook (F) to the quick link and tighten the nut on the quick link. Attach another quick link to the bottom end of the flag arrangement (J). Attach one end of the retainer ring (C) to the quick link and wrap the other end of the retainer ring around the pole and then attach to the quick link forming a complete loop. Attach one more snap hook and the counter weight (D) to the quick link as well and tighten the nut securing all parts at the end of the flag arrangement. If you used a small rope or twine remove it from the swivel on the cable at this time.

STEP 14 – After flag arrangement has been attached to outside cable end and winch is secured in place with the other end of cable attached to it, pull lightly on the outside cable to remove any kinks or slack on the cable on inside of pole. Insert winch handle (L) into winch and crank flag arrangement to the top of the flagpole (**CRANK CLOCKWISE TO GO UP**) to check action of the winch. **NEVER FORCE THE WINCH!!!** If it is sticking always back off and crank counter clockwise to allow cable to begin wrapping tightly on winch drum. When lowering the flag, do so in a controlled manor to prevent any injury or damage to the winch or operator.

STEP 15 – If you are using the flash collar, run a bead of clear silicone or self leveling cement sealant around the top of the flash collar where it meets the pole. This will help to seal out moisture

BE SURE TO LET YOUR CEMENT REST AT LEAST 24 HOURS BEFORE YOU PLACE THE FLAG ON YOUR FLAGPOLE.....

STEP 16 – Step back and enjoy your flag and flagpole.

FOR A VIDEO DEMONSTRATION OF THIS INSTALLATION PLEASE VISIT OUR WEBSITE www.colonialflag.com under “HOW TO” VIDEOS.

FOUNDATION DIMENSIONS

EXPOSED HEIGHT	A	B	C	D	E	F	G	H	I
20'0"	2'0"	6"	18"	12"	12"	6"	2'6"	30"	30"
25'0"	2'6"	6"	18"	12"	14"	6"	3'6"	30"	30"
30'0"	3'0"	6"	18"	12"	14"	6"	3'6"	30"	30"
35'0"	3'6"	6"	18"	12"	14"	6"	4'0"	36"	36"
40'0"	4'0"	6"	18"	12"	16"	6"	4'6"	42"	42"
45'0"	4'6"	6"	24"	12"	16"	6"	5'0"	48"	48"
50'0"	5'0"	8"	24"	15"	18"	6"	5'8"	48"	48"
60'0"	6'0"	10"	24"	18"	24"	6"	6'10"	48"	48"
70'0"	7'0"	12"	24"	18"	24"	6"	8'0"	60"	60"
80'0"	8'0"	12"	24"	18"	24"	6"	9'0"	60"	60"

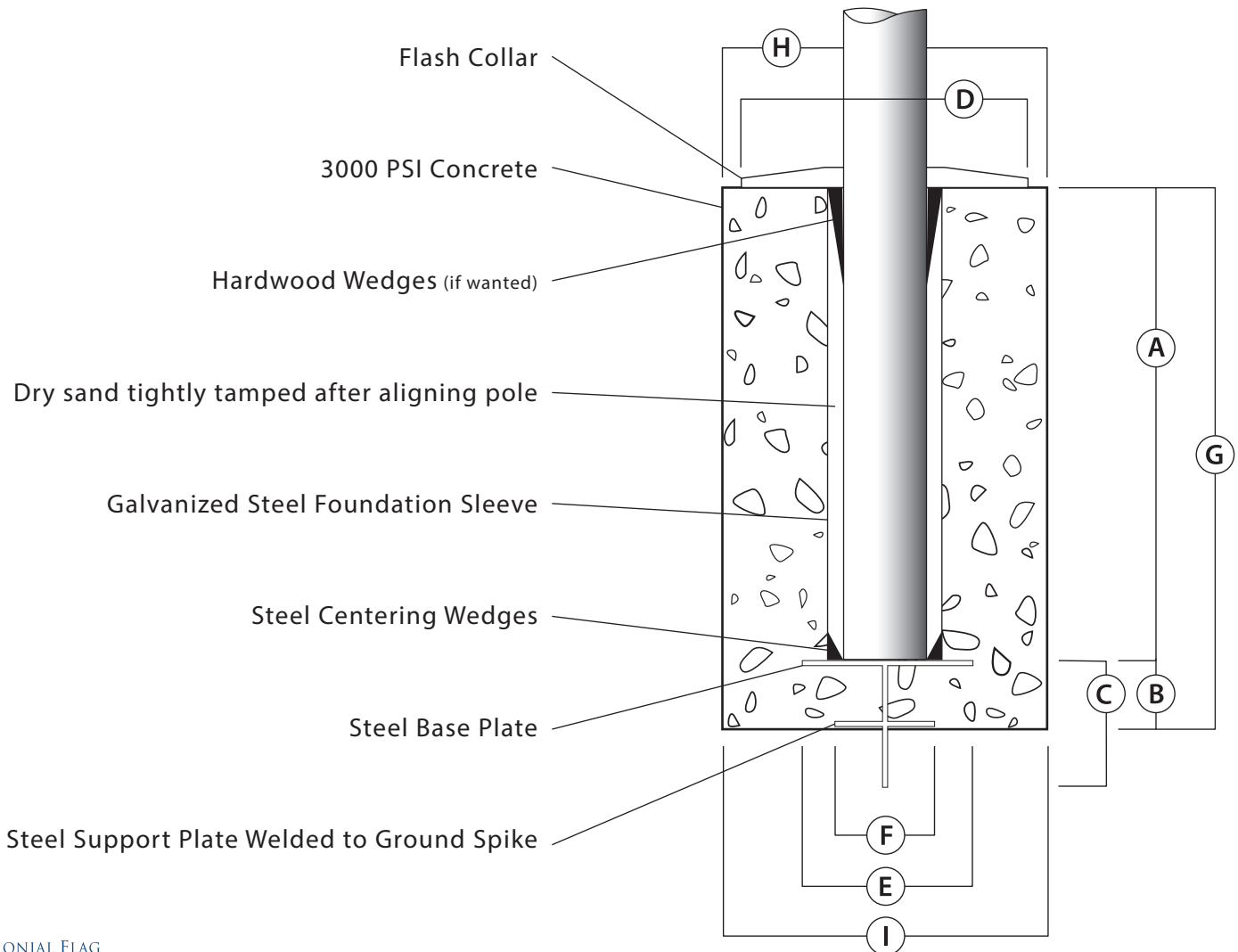

PARTS CHART

STAINLESS STEEL WINCH SYSTEM

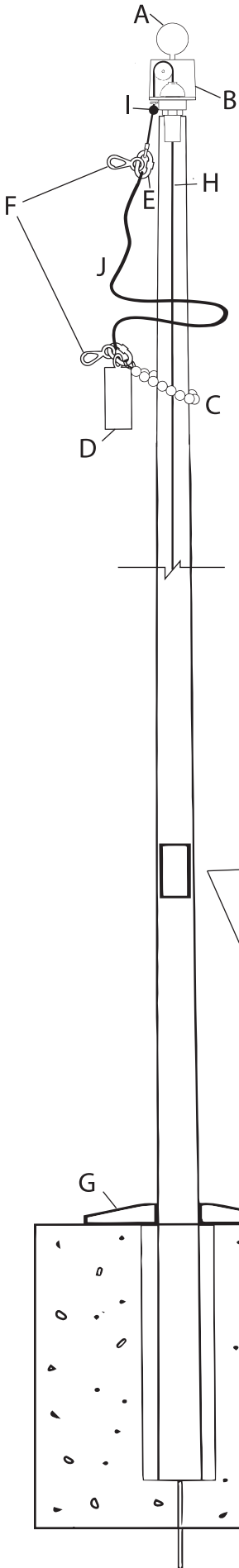

A- Ball



B- Revolving Truck



C- Retainer Ring



D- Counter Weight



E- Quick Link



F- Snap Hooks



G- Flash Collar



H- Cable Assembly



I- Nylon Stopper Ball



J- Flag Arrangement



K- Stainless Steel Winch



L- Crank

FRONT VIEW

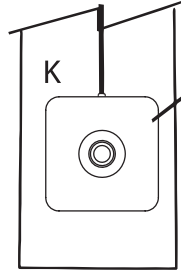

SIDE VIEW

