



[WWW.BACKUPBATTERYPOWER.COM](http://WWW.BACKUPBATTERYPOWER.COM)

**(855) 330-7799**

# **Battery Pack Installation User's MANUAL**

**Table of Contents**

- Chapter 1. IMPORTANT SAFETY INSTRUCTIONS .....2
- Chapter 2. Introduction to the Front and Rear Panel .....4
  - 2.1. Front and Rear Panel Descriptions .....4
- Chapter 3. Installation and Operation .....5
  - 3.1. Unpacking .....5
  - 3.2. Selecting Installation Position .....6
    - 3.2.1. Connect DC Cable .....7
  - 3.3. Storage Instruction .....8
  - 3.4. Specification .....9
  - 3.5. Recycling the Used battery .....11

# Chapter 1. IMPORTANT SAFETY INSTRUCTIONS

## ***SAVE THESE INSTRUCTIONS***

This manual contains important instructions that should be followed during installation and maintenance of the battery bank and batteries.

### ***Important Notice***

- This battery bank is connected to an UPS. There will be voltage at the output terminals if the UPS is turned on even if the input AC Mains is not available.
- Do not try to repair the unit yourself, contact your local supplier or your warranty will be void.
- To prevent overheating of the battery bank, keep all ventilation openings free from obstruction. Keep the battery bank front/rear panel 20 cm away from the wall.
- Make sure the battery bank is installed within the proper environment as specified. (0~40°C/32~104°F and 30-90%RH non-condensing)
- Do not install the battery bank at outdoor sites; this battery bank is designed for indoor use only.
- This battery bank is not designed for use in dusty, corrosive and salty environment.
- The warranty for this battery bank will be void if water or other liquid is spilt or poured directly onto the battery bank. Similarly we do not warrant any damage to the battery bank if foreign objects are deliberately or accidentally inserted into the battery bank enclosure.
- The battery will discharge naturally if the system is unused for a period of time. Long-term storage without recharge maintenance could cause batteries damaged.
- It should be recharged every 2-3 months if unused. If this is not done, then the Warranty will be null and void. During UPS normal operation, batteries will be automatically maintained in full charged condition.
- Servicing of batteries should be performed or supervised by trained personnel with knowledge of batteries and the required precautions.
- Replace only the same quantity, type & capacity batteries when needed.
- Make sure the battery is the same quantity/voltage before connect battery Cable.

- CAUTION – Do Not Dispose of Battery(ies) in open fire or high temperature environment. The Battery May Explode.
- CAUTION – Do not open or mutilate the batteries. The electrolyte of the batteries is toxic and harmful to the skin and eyes.
- CAUTION – Risk of electric shock – Battery circuit is not isolated from AC, hazardous Voltage may exist between battery terminals and ground. Test before touching with bare hands.
- CAUTION – A Battery can present a Risk of Electrical Shock and High Short Circuit Current. The Following Precaution Should be Observed When Working on Batteries:
  - A. Remove watches, rings, or other metal wearing objects.
  - B. Use tools with insulated handles and wear rubber gloves and boots.
  - C. Do not lay any metal tools or parts on top of batteries.
  - D. Disconnect charging source prior to connecting or disconnecting battery terminals.

# Chapter 2. Introduction to the Front and Rear Panel

## 2.1. Front and Rear Panel Descriptions

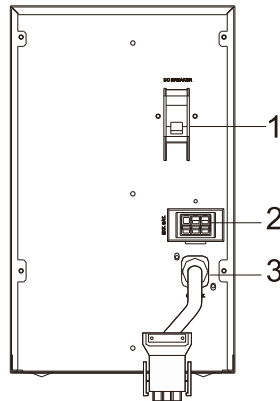
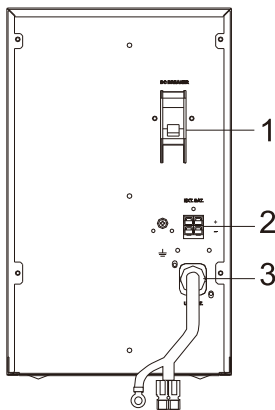
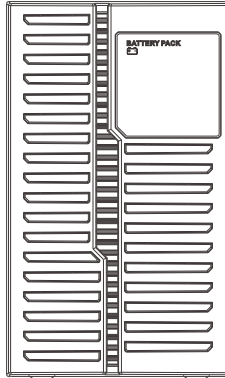

1. DC Breaker (Standard)	1. Battery Over-current Protection. 2. Easily remove battery bank from system.
2. Battery Connector	Battery bank extending connector.
3. DC Power Cord	To link with UPS and battery banks.

# Chapter 3. Installation and Operation

Note: The packing condition and the external outlook of the unit should be inspected carefully before installation. Retain the packing material for future use.

## 3.1. Unpacking

1. Remove the packing foams and take the battery bank out of the box.  
**Warning:** The unit could be quite heavy. Check the weight of the unit before operating to avoid injury.
2. Standard Package includes – User's Manual
3. Accessories for Tower and Rack Mount

### 3.2. Selecting Installation Position

It is necessary to select a proper environment to install the unit, in order to minimize the possibility of failure to the battery bank and extend the life of the batteries. Please follow the instructions below:

1. Keep at least 20cm (8 inches) clearance from the rear panel of the battery bank from the wall or other obstructions.
2. Do not block the air-flow to the ventilation openings of the unit.
3. Ensure the installation site environmental conditions are in accordance with the battery bank working specifications to avoid overheat and excessive moisture.
4. Do not place the battery bank in a dusty or corrosive environment or near any flammable objects.
5. This battery bank is not designed for outdoor use.

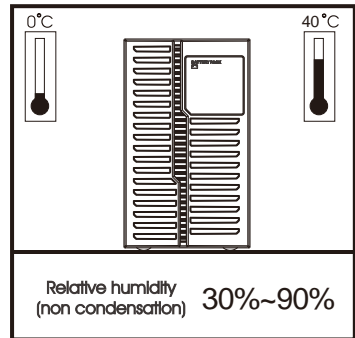
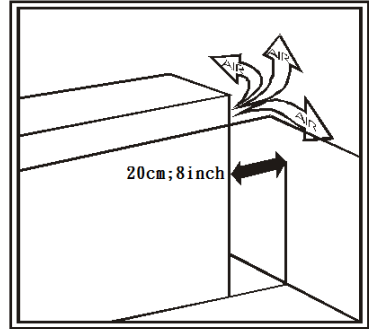

### 3.2.1. Connect DC Cable

4P

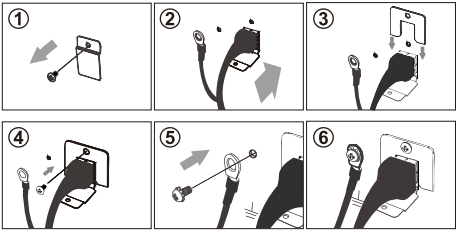
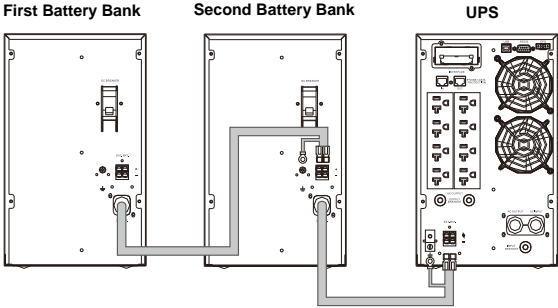

6P

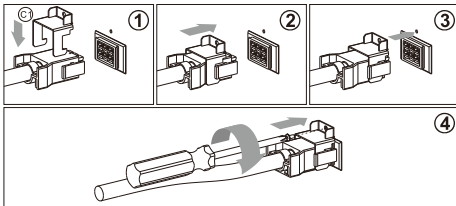
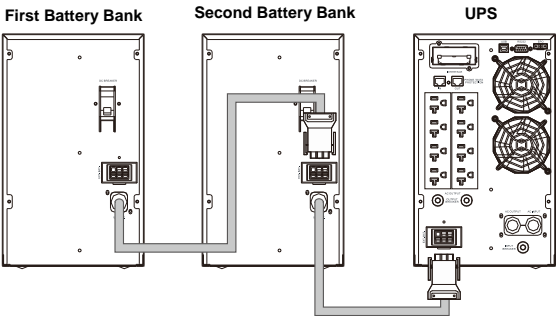



### 3.3. Storage Instructions



For extended storage through moderate climates (-15 to +30 °C / +5 to +86 °F), the batteries should be charged for 12 hours every 6 months by plugging the UPS power cord into the wall receptacle or by an external charger. Repeat this every 3 months under high temperature (+30 to +45 °C / +86 to +113 °F) environments.

**Warning:** The lead-acid batteries will drain naturally and become damaged by long-term self-discharge without maintenance.

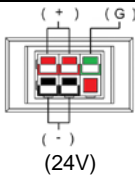
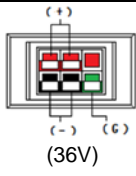
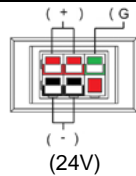
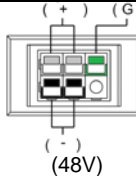
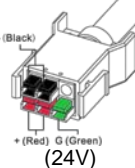
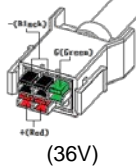
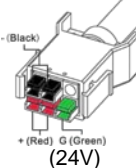
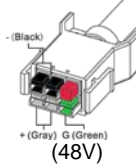
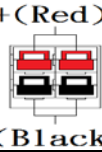
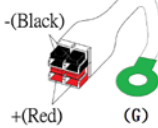
### 3.4. Specification

UPS	120V 1KVA (24V)	120V 1.5KVA (36V)	120V 1KVA (24V)	120V 2KVA (48V)
	230V 1KVA (24V)	230V 1KVA (36V)	230V 1KVA (24V)	230V 2KVA (48V)
<b>Model code *</b>	BBP-AR-1000-PSW-ONL-EBP-6B	BBP-AR-1500-PSW-ONL-EBP	BBP-AR-1000-PSW-ONL-EBP-8B	BBP-AR-2000-PSW-ONL-EBP
<b>Voltage Rating</b>	24VDC	36VDC	24VDC	48VDC
<b>Capacity x Strings</b>	7/9Ah x 6	7/9Ah x 6	7/9Ah x 8	7/9Ah x 8
<b>DC Sockets 6p</b>	 (24V)	 (36V)	 (24V)	 (48V)
<b>DC Plugs 6p</b>	 (24V)	 (36V)	 (24V)	 (48V)
<b>DC Sockets 4p</b>	 + (Red) - (Black)			
<b>DC Plugs 4p</b>	 + (Red) G (Green) - (Black)			
<b>Dimensions (WxHxD,inch/mm)</b>	6.06 x 10.16 x 15.89 154 x 258.2 x 403.6	6.06 x 10.16 x 15.89 154 x 258.2 x 403.6	6.73 x 11.32 x 17.34 171 x 287.6 x 440.6	6.73 x 11.32 x 17.34 171 x 287.6 x 440.6
<b>Weight (kg/lb)</b>	W7Ah : 17.7kg W9Ah : 19.5kg	W7Ah : 17.7kg W9Ah : 19.5kg	W7Ah : 24.6kg W9Ah : 27.0kg	W7Ah : 24.6kg W9Ah : 27.0kg
<b>Recommended Recharge Current</b>	0.1C ~ 0.25C(max)			
<b>Output Current (max)</b>	50A			
<b>Output Protector</b>	P series : ( + )Breaker : 50A & ( - ) Fuse : 30A x 2 B series : ( + )Breaker : 50A & ( - ) Breaker : 50A F series : ( + ) Fuse : 30A x 2 & ( - ) Fuse : 30A x 2			
<b>Operation Environment</b>	0~40°C / 32~104°F, 30-90%RH non-condensing			
<b>Storage Environment</b>	-15~45°C, 30-90%RH non-condensing			
<b>Compliance</b>	CE / cTUVus			

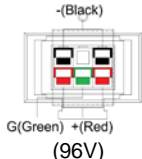
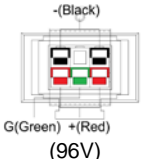
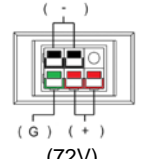
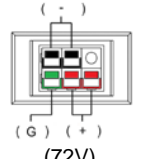
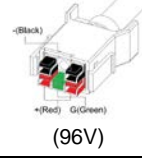
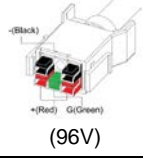
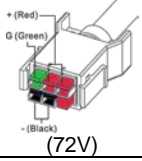
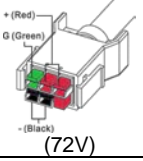
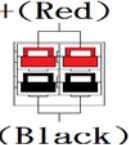
\* X: 4 or 6, Y: B or P or F

UPS			120V 3KVA (72V)	120V 3KVA (72V)
	230V 3KVA (96V)	230V 3KVA (96V)	230V 2/3KVA (72V)	230V 2/3KVA (72V)
<b>Model code *</b>	BBP-AR-3000-PSW-ONL-EBP-8B	BBP-AR-3000-PSW-ONL-EBP-16B	BBP-AR-3000-PSW-ONL-EBP-18B	BBP-AR-3000-PSW-ONL-EBP-12B
<b>Voltage Rating</b>	96VDC	96VDC	72VDC	72VDC
<b>Capacity x Strings</b>	7/9Ah x 8	7/9Ah x 16	7/9Ah x 18	7/9Ah x 12
<b>DC Sockets 6p</b>				
<b>DC Plugs 6p</b>				
<b>DC Sockets 4p</b>				
<b>DC Plugs 4p</b>				
<b>Dimensions (WxHxD,inch/mm)</b>	6.73 x 11.32 x 17.34 171 x 287.6 x 440.6	7.56 x 12.6 x 21.76 192 x 319.9 x 552.8	7.56 x 12.6 x 21.76 192 x 319.9 x 552.8	7.56 x 12.6 x 21.76 192 x 319.9 x 552.8
<b>Weight (kg/lb)</b>	W7Ah : 24.6kg W9Ah : 27.0kg	W7Ah : 44.3kg W9Ah : 49.1kg	W7Ah : 48.6kg W9Ah : 54.0kg	W7Ah : 40.0kg W9Ah : 44.2kg
<b>Recommended Recharge Current</b>	0.1C ~ 0.25C(max)			
<b>Output Current (max)</b>	50A			
<b>Output Protector</b>	P series : ( + )Breaker : 50A & ( - ) Fuse : 30A x 2 B series : ( + )Breaker : 50A & ( - ) Breaker : 50A F series : ( + ) Fuse : 30A x 2 & ( - ) Fuse : 30A x 2			
<b>Operation Environment</b>	0~40°C / 32~104°F, 30-90%RH non-condensing			
<b>Storage Environment</b>	-15~45°C, 30-90%RH non-condensing			
<b>Compliance</b>	CE / cTUVus			

\* X: 4 or 6, Y: B or P or F

### 3.5. Recycling the Used battery

Contact your local recycling or hazardous waste center for information on proper disposal of the used battery.

