

TAMPERE S 40

Installation drawings



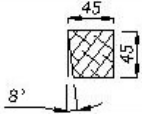

marking			length	pcs	
extra	WALL LOG 40x146		3406	1	
001.	WALL LOG 40x146		3406	2	
002.	WALL LOG 40x146		3206	2	
003.	WALL LOG 40x146	<i>includes 1 extra</i>	2280	33	
003A	WALL LOG 40x68		2280	2	
003B	WALL LOG 40x146		2280	1	
003C	WALL LOG 40x146		2280	2	
004C	WALL LOG 40x146		1700	2	
005.	WALL LOG 40x146		1212	14	
006C	WALL LOG 40x146		700	2	
007.	WALL LOG 40x146		368	14	
008.	WALL LOG 40x146		290	26	
	HAMMER BLOCK 40 MM			2	
AR-1	45x95 FLOOR FRAME		2876	1	
AR-2	45x95 FLOOR FRAME (CUTOUT FOR DRAINAGE)		2876	1	
AR-3	45x95 FLOOR FRAME (SPECIAL CROSS-SECTION)		1980	1	
AR-4	45x70 FLOOR FRAME		1980	1	
AR-5	45x95 FLOOR FRAME		1980	9	
TL-1	28x120 DECKING BOARD		800	18	
TL-2	28x120 DECKING BOARD		2070	1	
PL-1	28x120 FLOOR BOARD		1960	21	
SR-1	45x145 ROOF RAFTER		3406	2	
KL-1	29x120 ROOF BOARD		2668	34	

SL-1	STP 14x121 INTERNAL CEILING BOARD		2015	20	
TR-1	45x45 SUPPORT DETAIL FOR SL-1		2000	2	
					
SL-2	15X55 DISTANCE BOARD FOR SL-1		2000	4	
RL-2	45x45 ROOF EDGE SUPPORT		3406	2	
RL-1	18x95 ROOF EDGE BOARD		~3,5	2	
RL-1	18x95 ROOF EDGE BOARD		~2,8	2	
PP-1	15x55 FLOOR AND CEILING MOULDINGS		~2,1	8	
SR-4	15x55 MOULDING FOR OUTSIDE GAP		~2,1	2	
	WINDOW 845x1792			2	
	DOOR 690x1860			1	
	18x95 DOOR MOULDING extra		~2,4	2	
UK-1	18x95 DOOR MOULDING vertical		1890	2	
UK-2	18x95 DOOR MOULDING horizontal		920	1	
UK-3	15x55 DOOR MOULDING horizontal		670	1	
AK-1	18x95 WINDOW MOULDING horizontal		1900	2	
AK-2	18x95 WINDOW MOULDING vertical		1877	4	
AK-3	18x95 WINDOW MOULDING horizontal		1650	2	
AK-4	15x55 WINDOW MOULDING vertical, center		1752	2	
VS-1	GRID WALL 650x1715			1	
NP-1	70x70 CORNER POST		1912	1	
LM-1	BENCH MODULE UPPER, 600x1992			1	
LM-2	BENCH MODULE LOWER, 400x1992			1	
LM-3	OUTDOOR BENCH 536x750			1	
	BENCH SUPPORTS 45x45			1	

	VENTILATION LOUVER WOOD D100			2	
	VENTILATION GRID METAL D100			2	
	SPU CEILING INSULATION 30x600x1200			6	
	FOIL TAPE			1	
RN-1	WATER DRAINAGE GUTTER 2000 MM+			1	
	FLOOR SLOPE DETAIL 3 MM		1995	1	
	FLOOR SLOPE DETAIL 6 MM		1995	1	
	FLOOR SLOPE DETAIL 9 MM		1995	1	
	FLOOR SLOPE DETAIL 12 MM		1995	1	
	SCREW 3,5x40 FOR MOULDINGS			100	
	SCREW 4,2x55 FOR ROOF EDGE BOARDS AND TERRACE			200	
	SCREW 4,8x90 FOR CONNECTION WALL CORNERS			300	
	SCREW 4,2x55 FOR FLOOR BOARDS			200	
	SCREW 4,5x60 ASSY FOR ROOF SUPPORT			100	
	SCREW 5,0x90 ASSY FOR FLOOR FRAME AND WALL LOGS			100	
	SCREW 4,5x80 ASSY FOR BENCH SUPPORTS			20	
	SCREW 6x180 FOR WALL LOGS AND ROOF RAFTERS			25	
	NAIL 75 MM FOR ROOF BOARDS			~400	
	NAIL 1.4x40 INTERNAL CEILING BOARD			~350	
	SCREW 4,8x40 FOR METAL CORNER BRACKETS			10	
	METAL CORNER BRACKET FOR GRID WALL			3	
	WASHER M5 FOR CORNER BRACKET SCREWS			3	
	POST HEIGHT ADJUSTMENT FOR NP-1			1	

	<i>extra</i>	<i>1 pcs</i>	
	<i>001</i>	<i>2 pcs</i>	
	<i>002</i>	<i>2 pcs</i>	
	<i>003</i>	<i>33 pcs</i> <i>(includes 1 extra)</i>	
	<i>003A</i>	<i>2 pcs</i>	
	<i>003B</i>	<i>1 pcs</i>	
	<i>003C</i>	<i>2 pcs</i>	
	<i>004C</i>	<i>2 pcs</i>	
	<i>005</i>	<i>14 pcs</i>	
	<i>006C</i>	<i>2 pcs</i>	
	<i>007</i>	<i>14 pcs</i>	
	<i>008</i>	<i>26 pcs</i>	

TOP VIEW

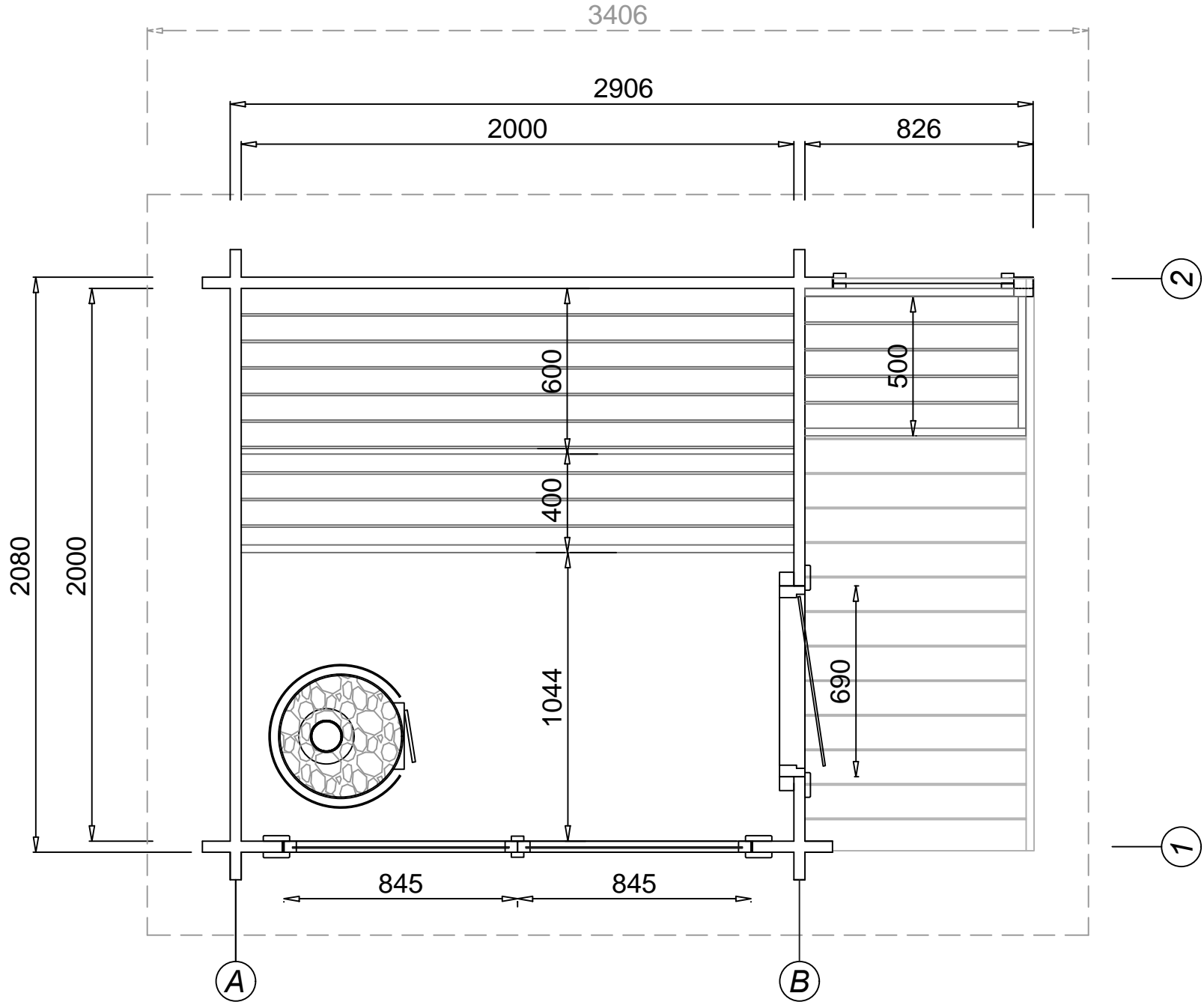

CROSS-SECTION

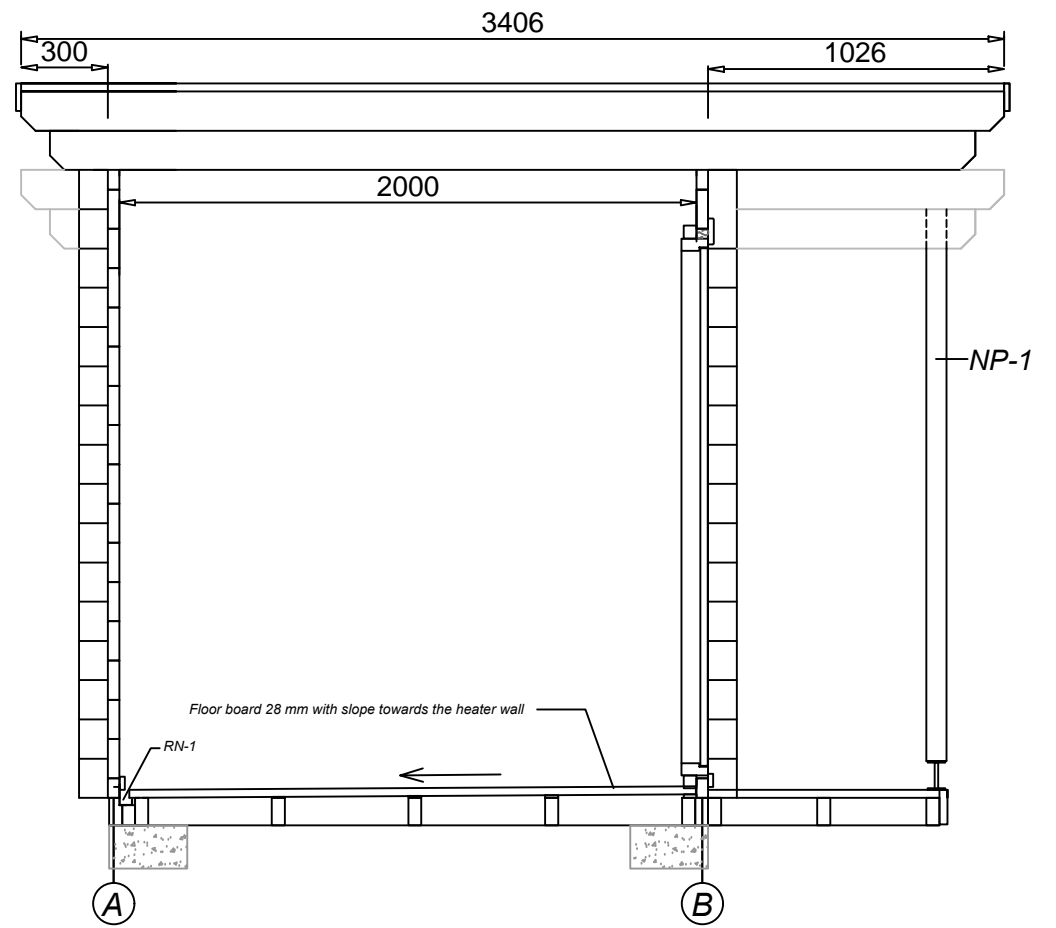
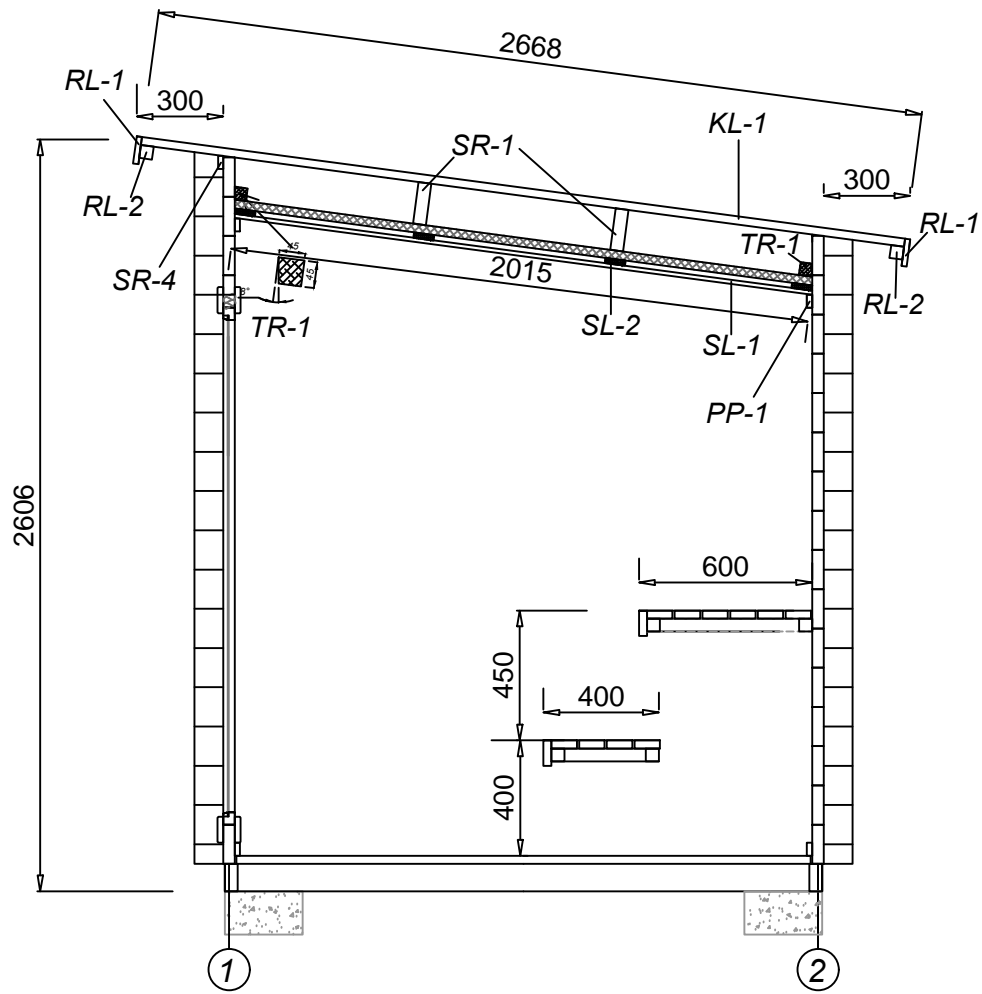

BASEMENT POSITIONING

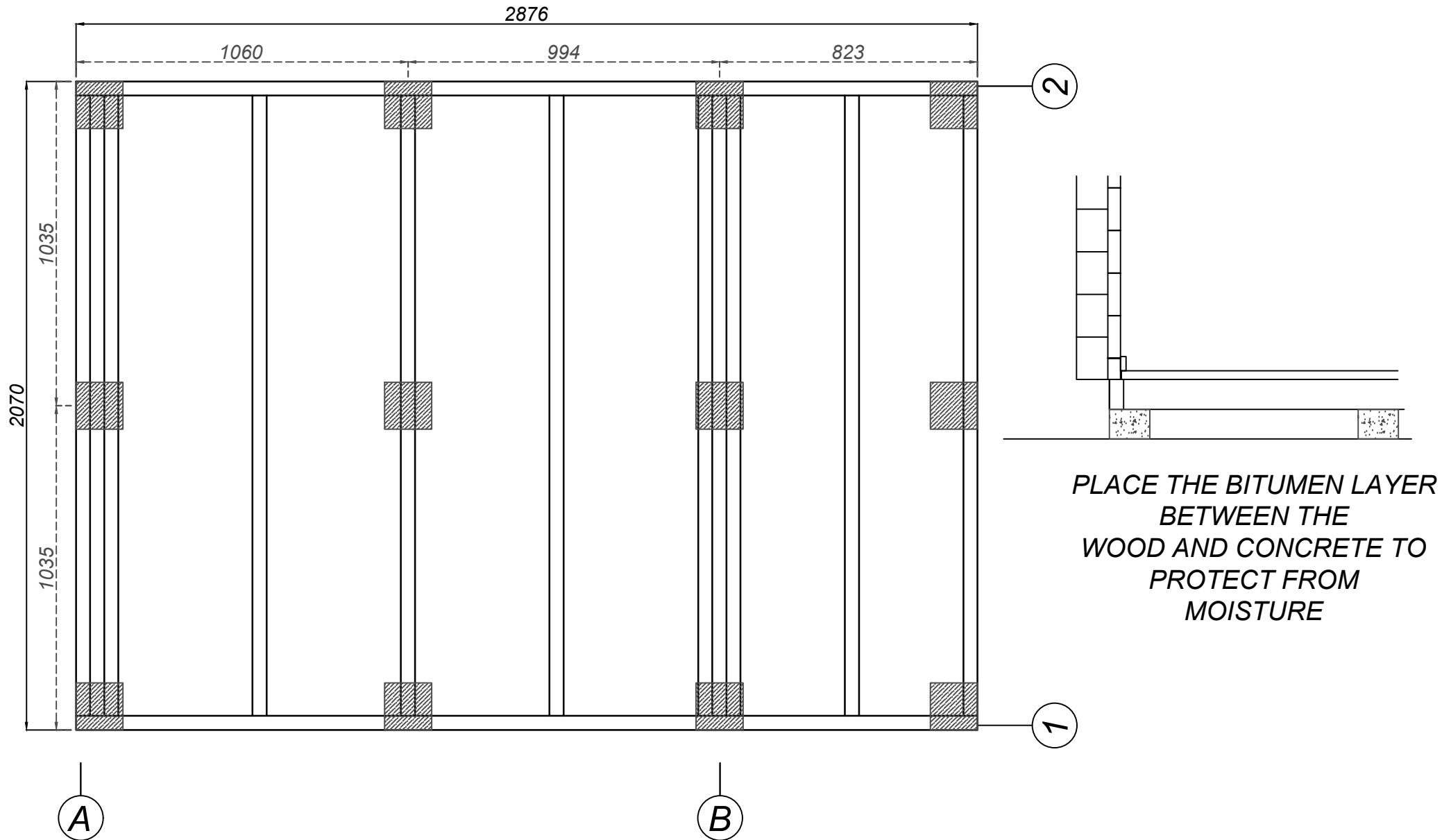

FLOOR FRAME 45x95

ADD DISTANCE BOARDS UNDER THE FLOOR BOARDS
FOR FLOOR SLOPE

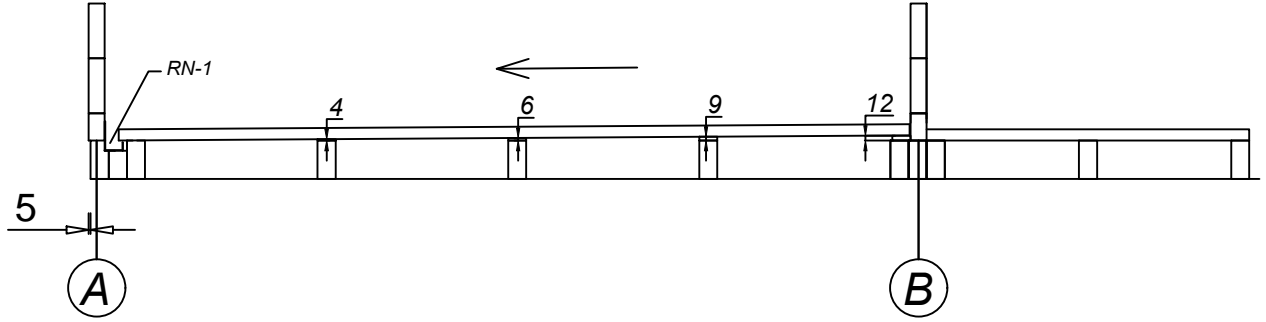

AR-3 CROSS-SECTION

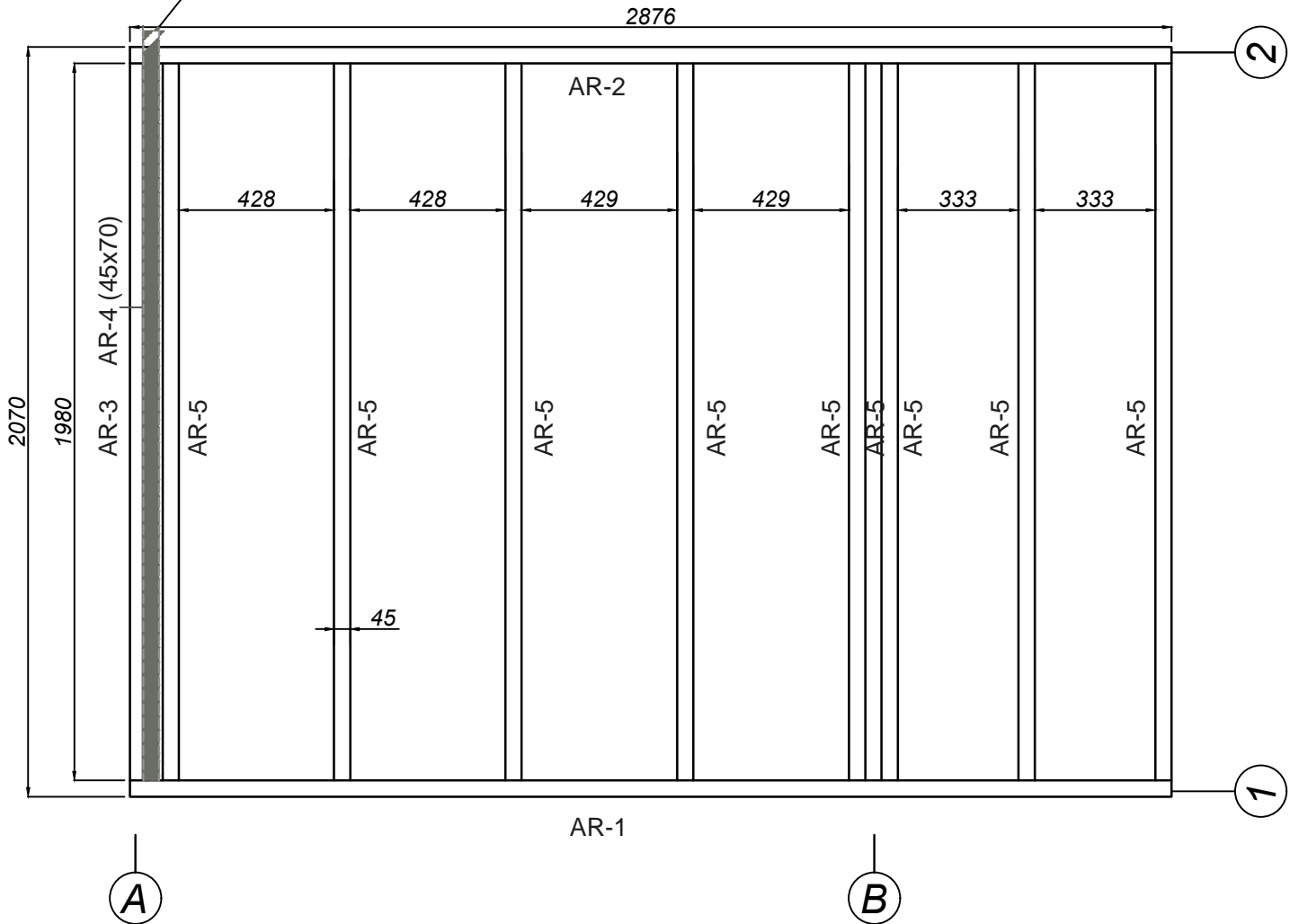
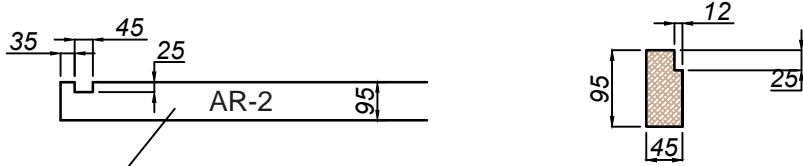

FLOOR FRAME

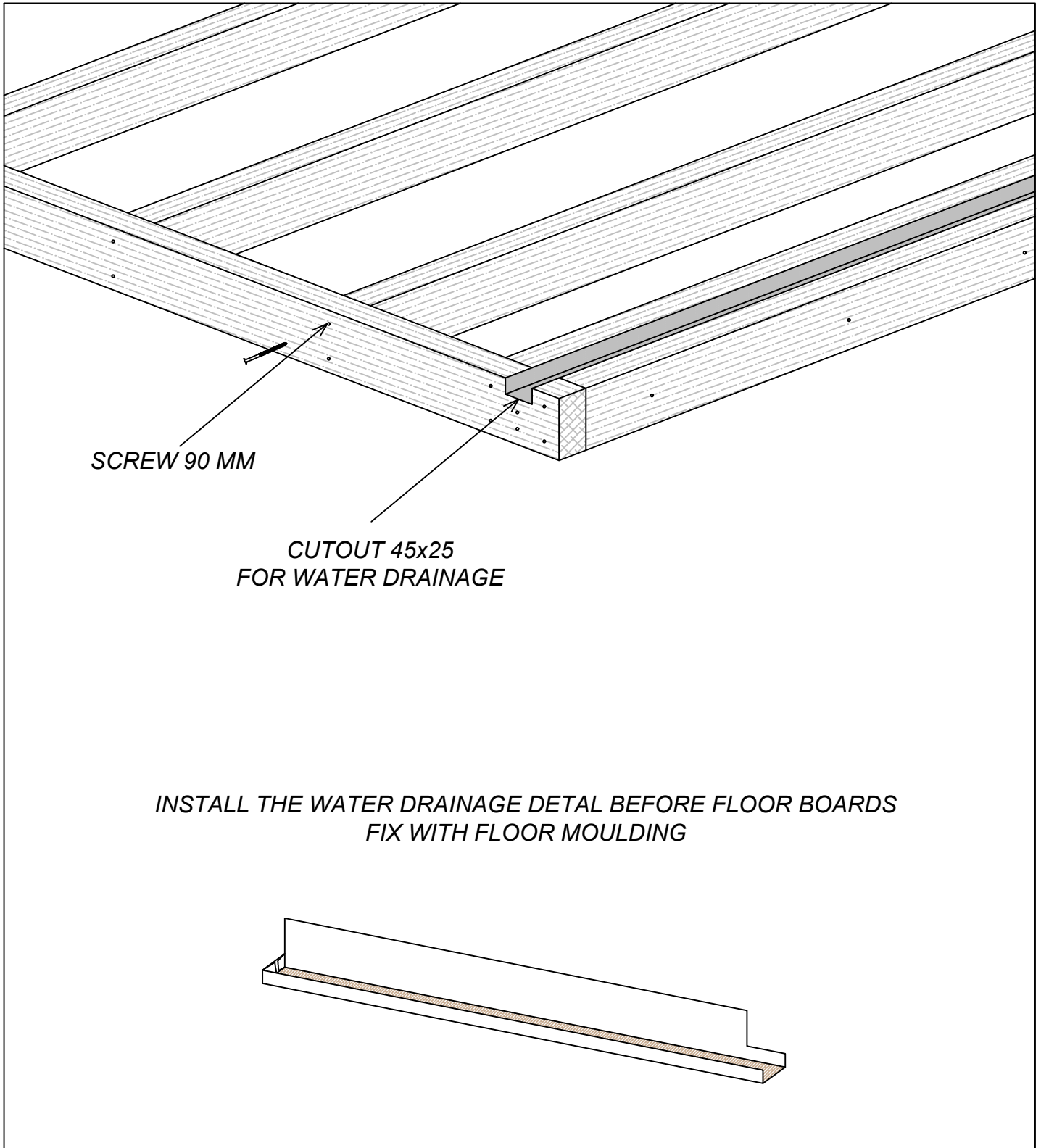

FIRST ROW

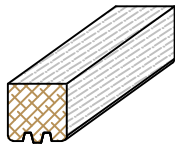
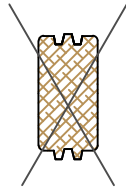

Use rubber hammer and hammer block

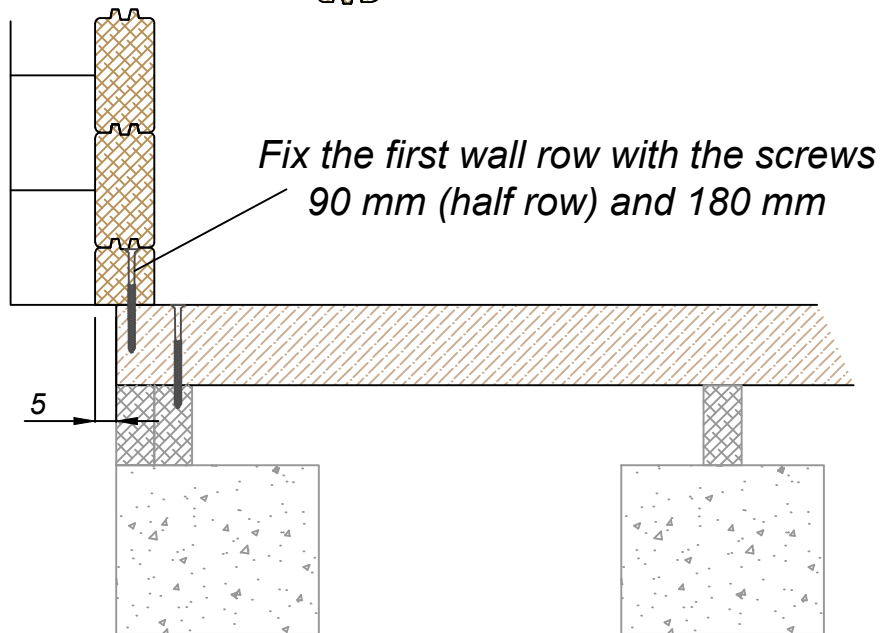

**IN EACH CONNECTION USE 90 MM SCREWS
(TO PROTECT THE BUILDING FOR WIND)**



WALL 1

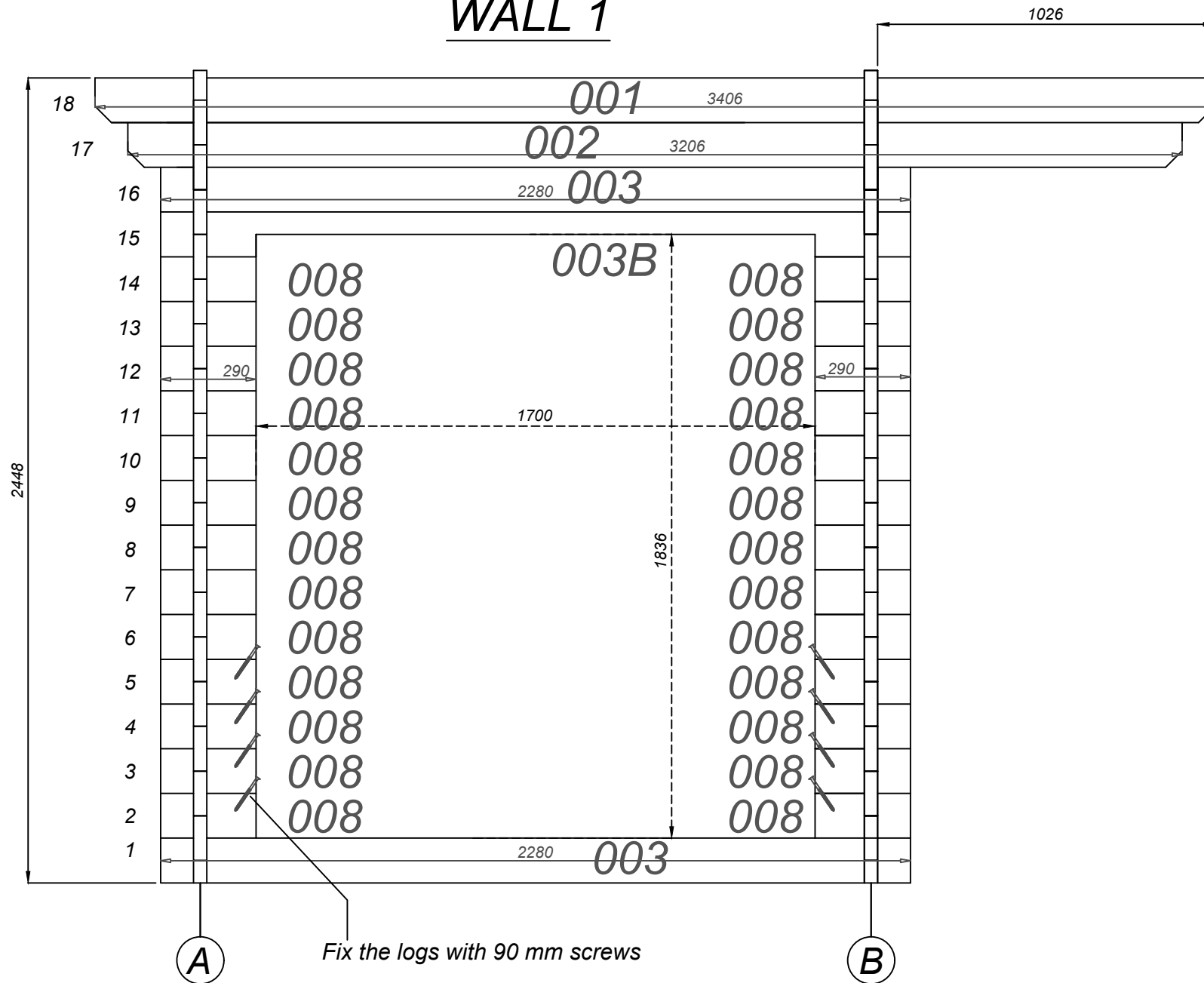

WALL 2

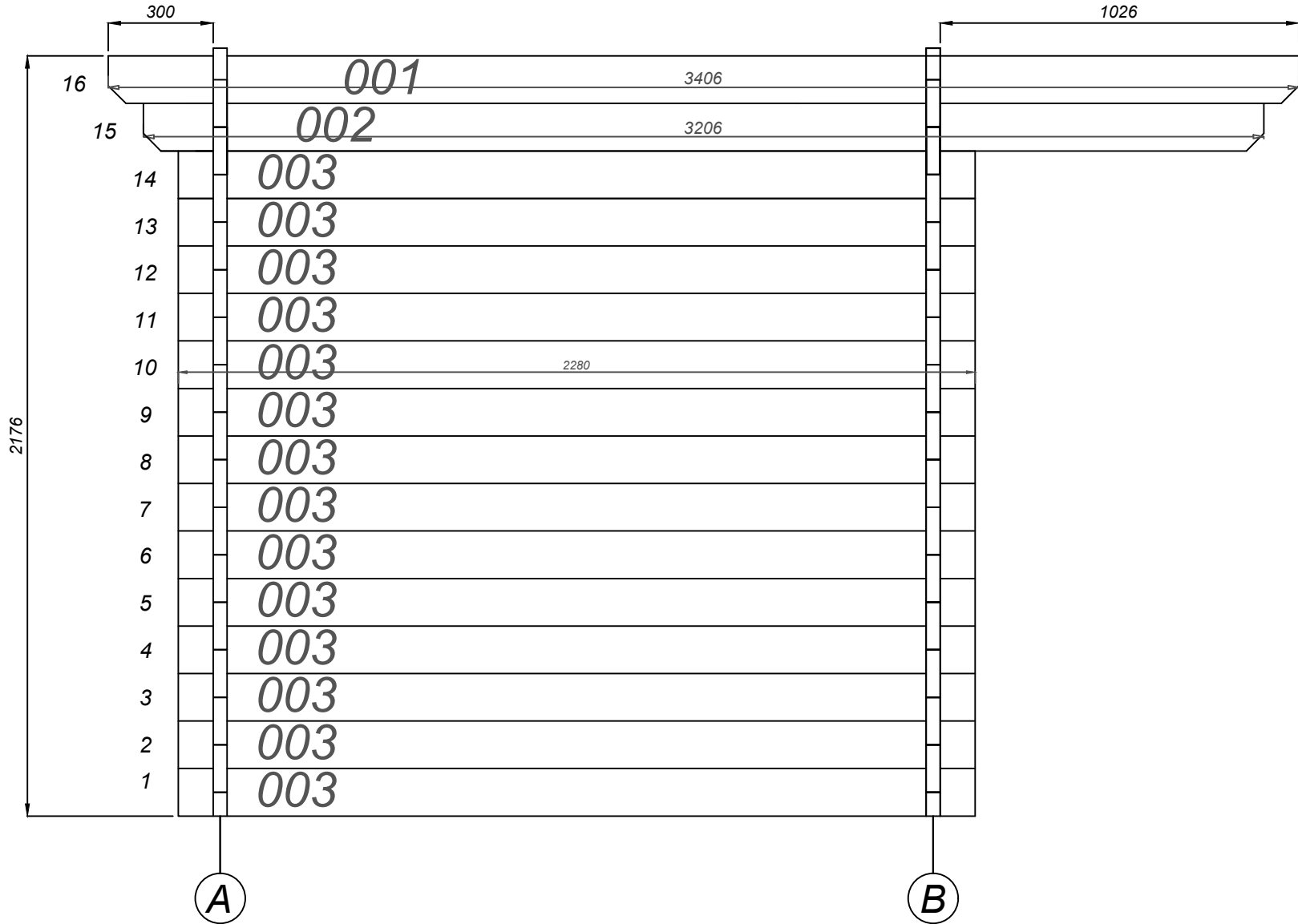

WALL A

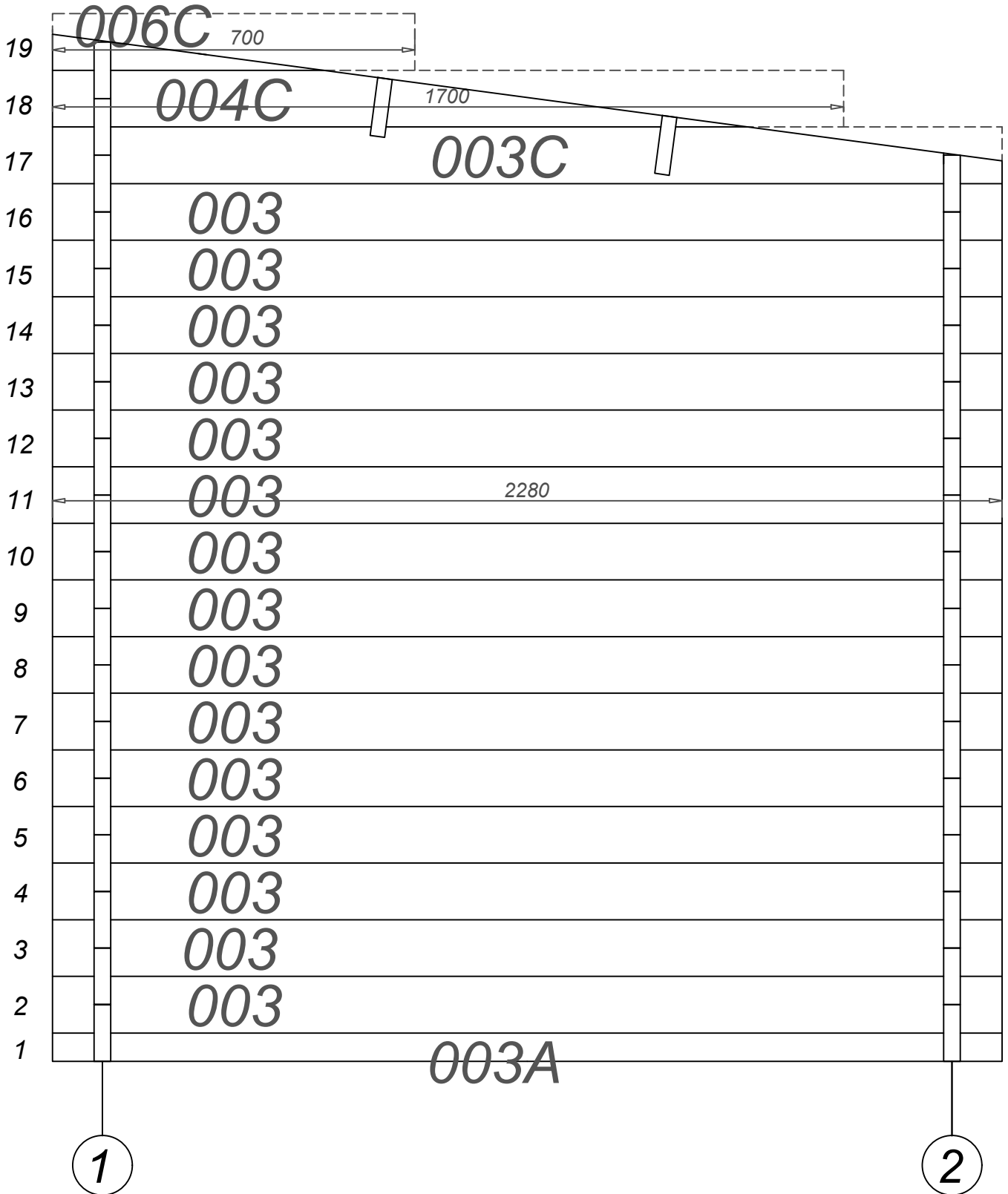

WALL B

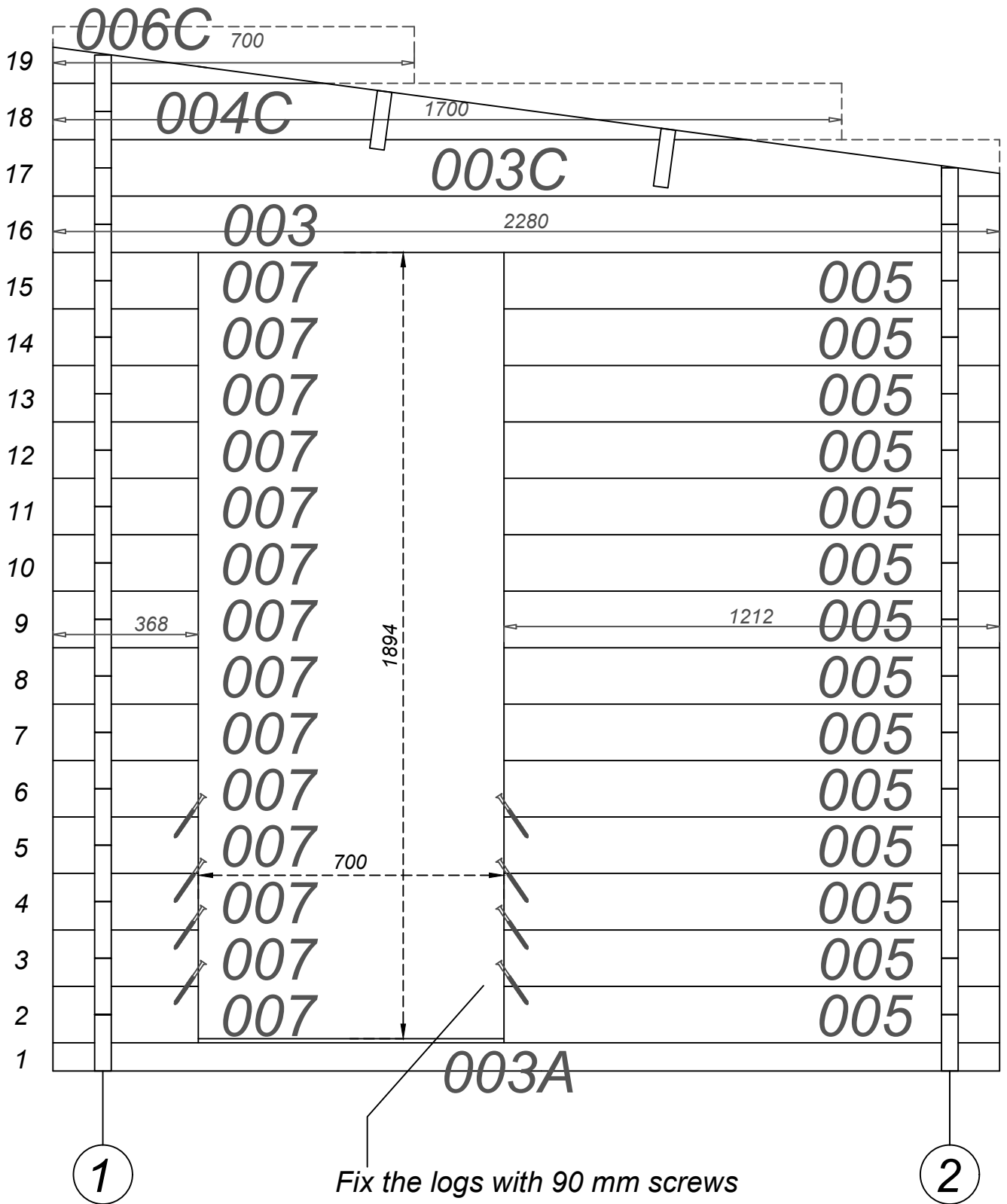

ROOF RAFTER SR-1 - 2 pcs

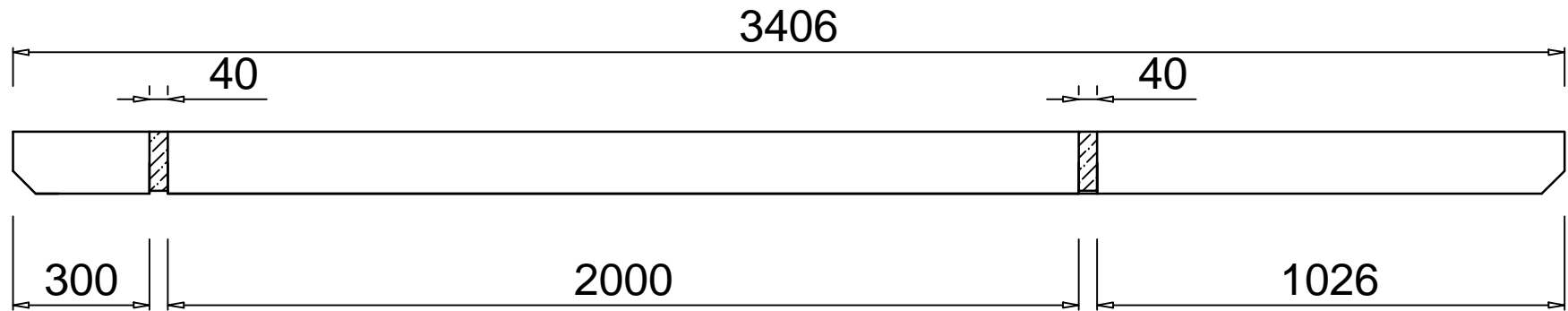

GRID WALL VS-1

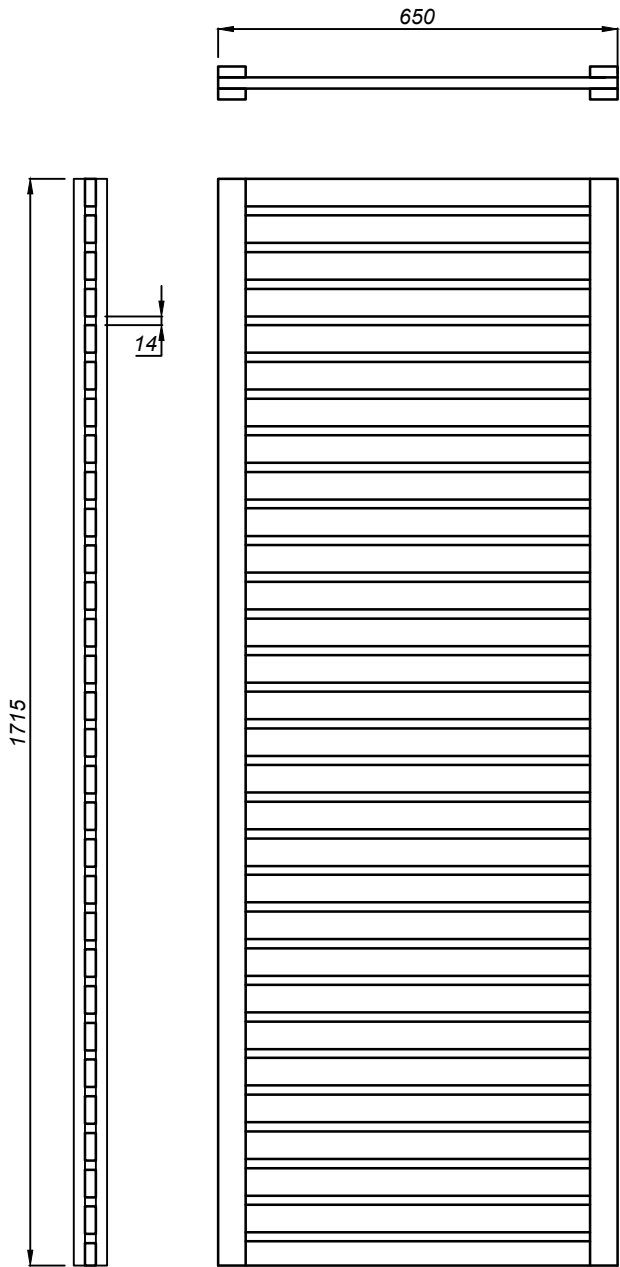

CORNER POST NP-1

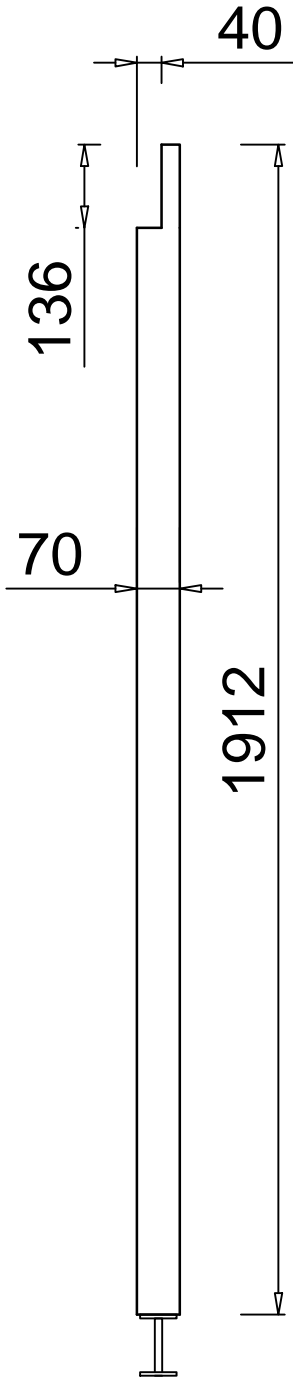

WINDOW MOULDINGS

Inside and outside mouldings are with the same length
Fix the mouldings with a 40 mm screws (stainless)

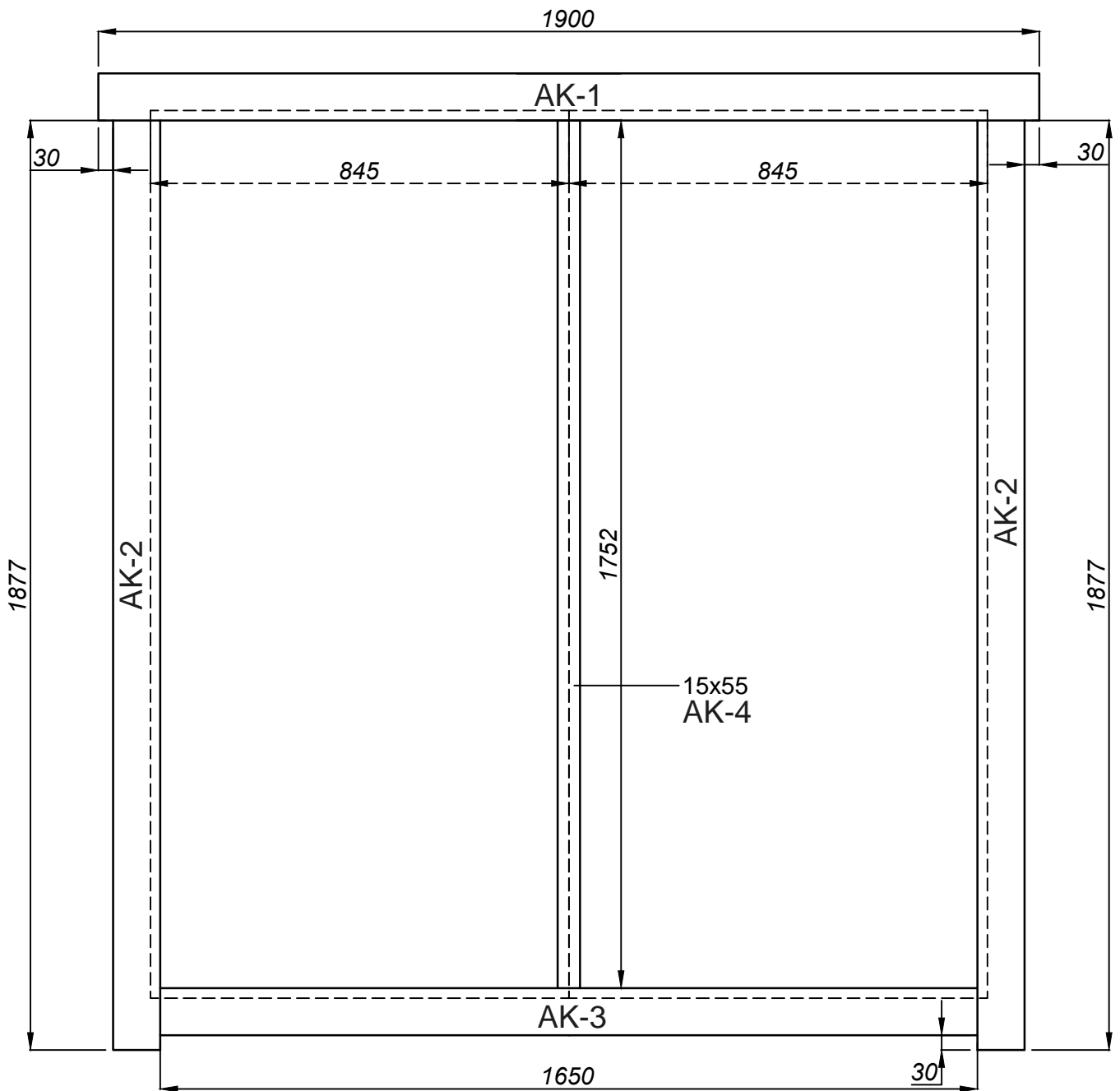

FIX THE WINDOWS TO THE WALL WITH THE MOULDINGS,
USING THE 40 MM STAINLESS SCREWS

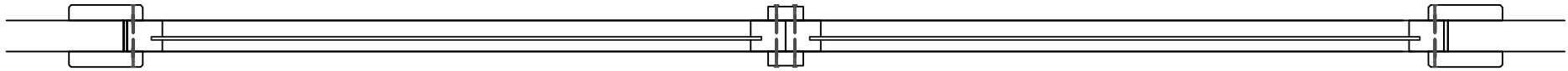

FIX THE DOOR TO THE WALL WITH THE 55 MM STAINLESS SCREWS
FIX THE MOULDINGS USING THE 40 MM STAINLESS SCREWS

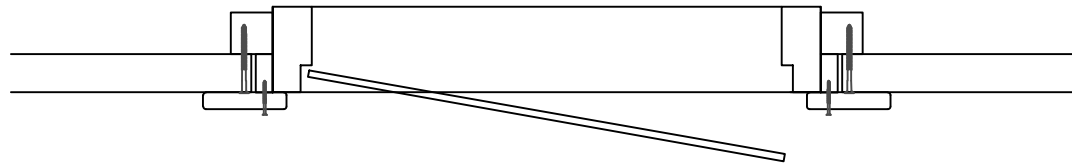

DOOR MOULDINGS (OUTSIDE DOOR)

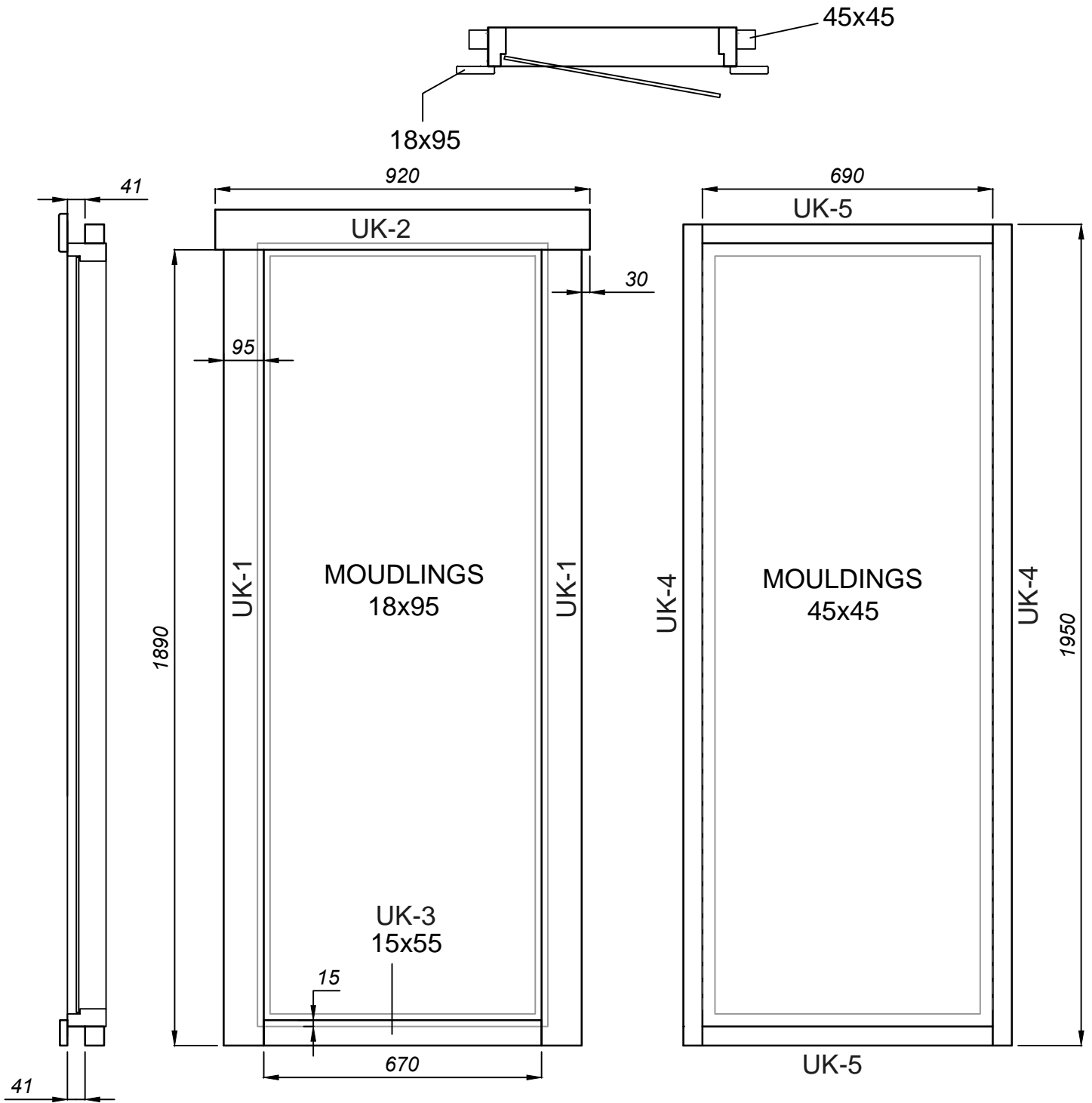

FLOOR BOARDS AND DECKING BOARDS

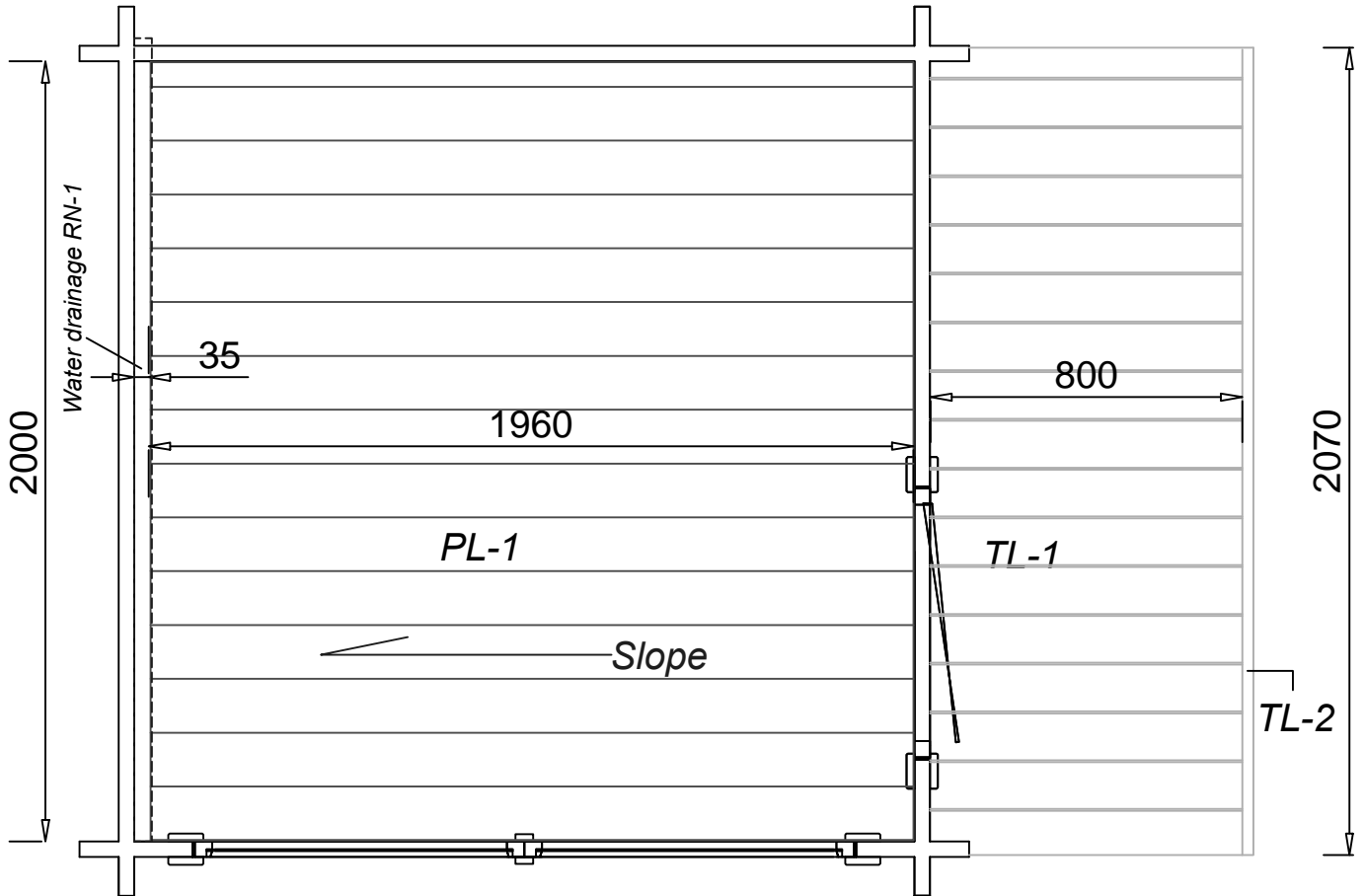

BEFORE THE FLOOR BOARD, INSTALL FLOOR SLOPE DETAILS

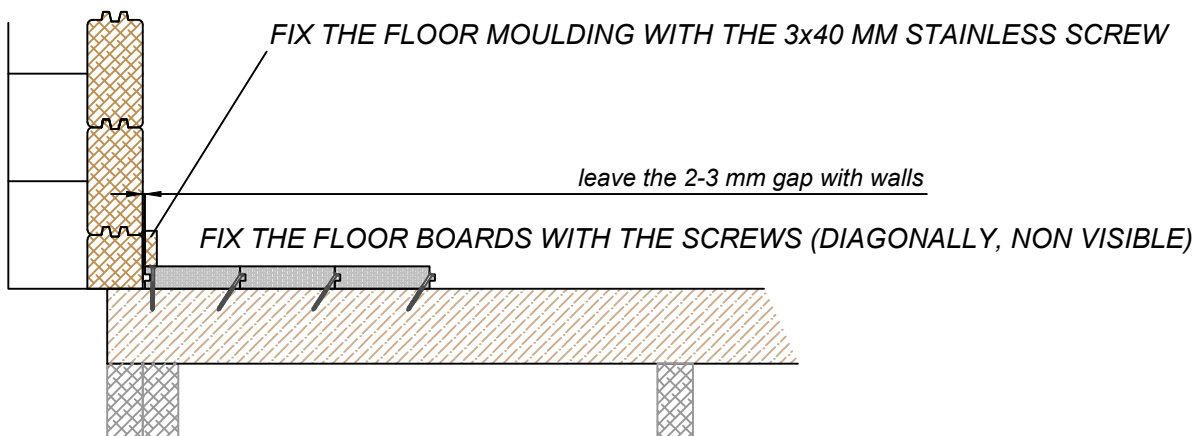

BENCH SET

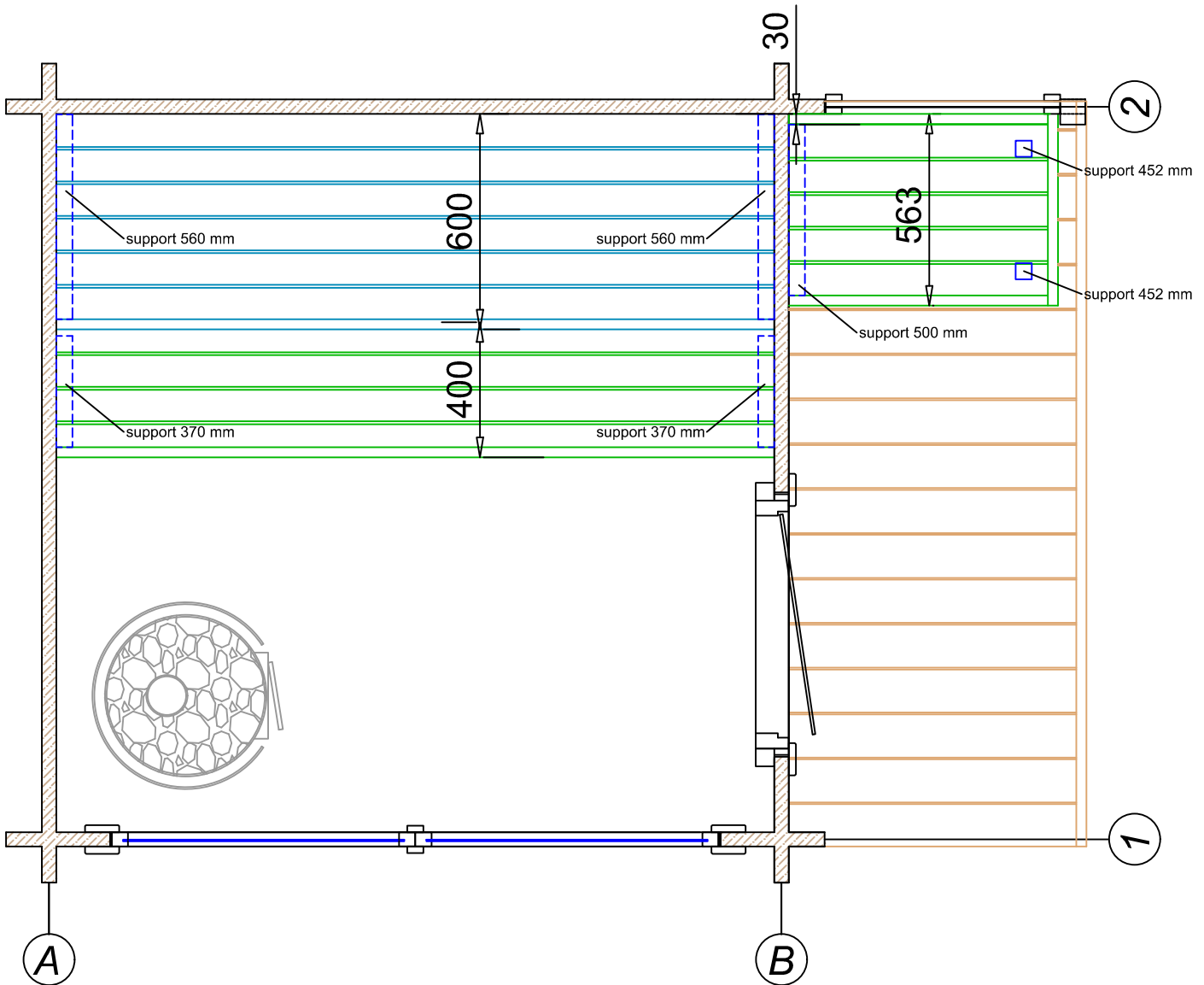

BENCH SUPPORTS

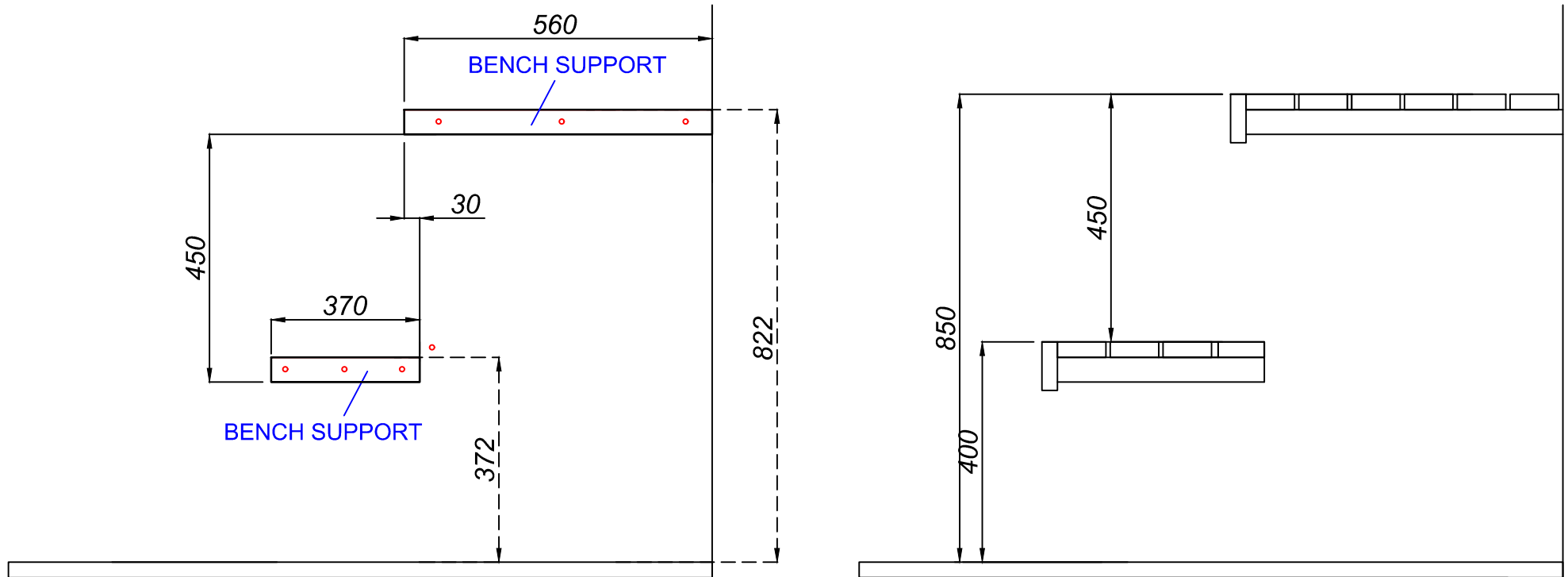

1. FIRST FIX THE BENCH SUPPORTS TO THE WALL
2. THEN LIFT THE BENCHES ON TOP OF THEM
3. FIX THE BENCHES WITH THE 70 MM SCREWS TO THE WALLS AND SUPPORTS