

HOLLYWOOD RACKS

RACK VALET™

Mobile hitch rack storage solution

Fits all 1 ¼" and 2" hitch racks

Assembly & Use Instructions

Parts Included (Fig. 1):

Item	Description	Quantity
A	welded tube frame	1
B	support legs	2 each
C	8mm bolts	4 each
	8mm nuts	4 each
	8mm flat washers	4 each
	8mm split washers	4 each
D	10mm nuts	4 each
	10mm flat washers	4 each
	10mm split washers	4 each
E	locking caster	4 each

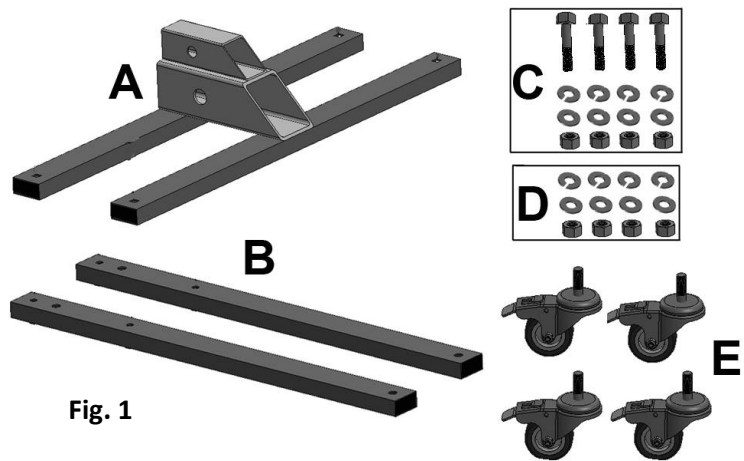

Fig. 1

Tools Required: two adjustable wrenches or two 13mm (1/2") and one 17mm wrench.

Assembly:

1. Per Fig. 2, position the legs (B) below the frame (A) as shown. Insert the 8mm bolts (C) through frame and legs from the bottom up. Install the 8mm flat washers, then split washers and 8mm nuts onto bolts. Tighten securely using the adjustable or 13mm wrenches. **Be sure rear bolts are installed into the rear most holes per Fig. 2.**

2. Per Fig. 4, carefully press down on the tab of the caster (E) so it will not spin. Per Fig. 3, Insert threaded stem of the caster through the hole. Install (D) 10mm flat washer, then split washer and nut onto threaded stem. Next, hold the caster and tighten the nut with adjustable or 17mm wrench. Repeat for other three casters.

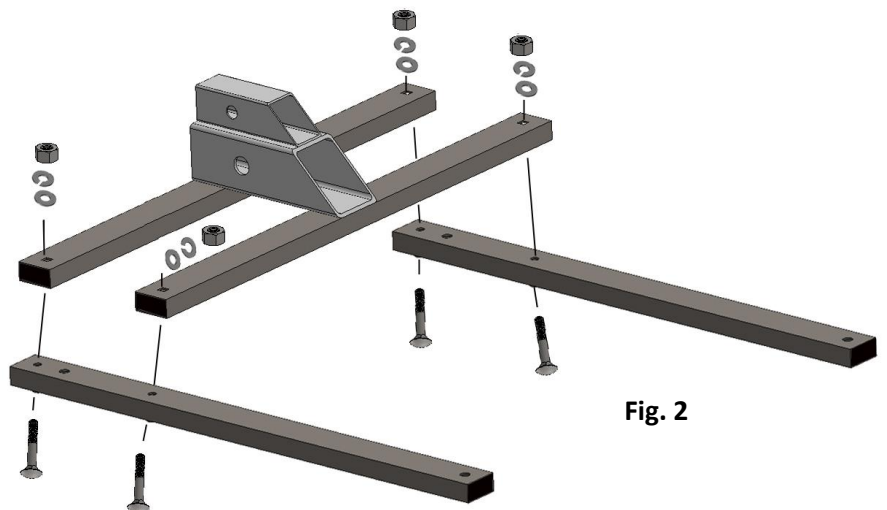

Fig. 2

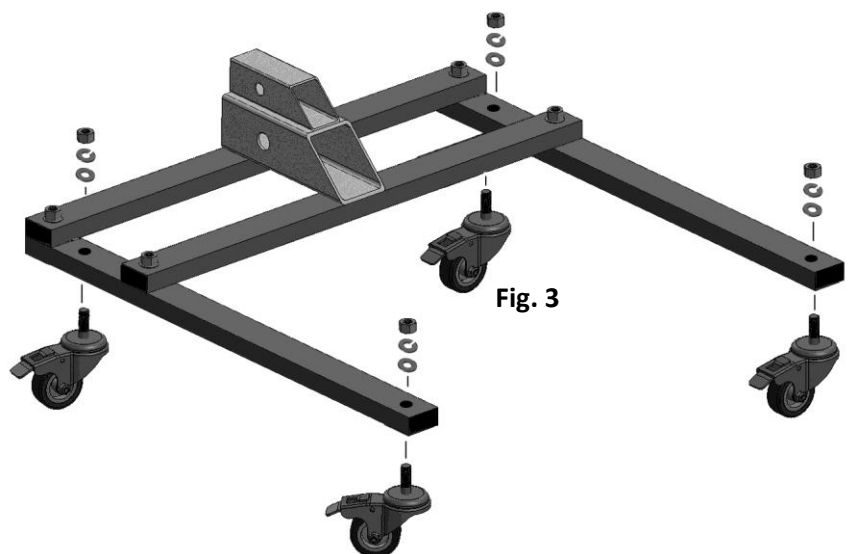

Fig. 3

LOCKING THE CASTER (Fig. 4): Wearing shoes, gently press the tab of the caster down with your foot to lock it. When locked, the caster will not spin or roll. (**NOTE:** The tab should not be pressed flat against the wheel. If by accident it is “over pressed”, you will need to pull it by inserting a small flat screwdriver between the wheel and tab, then gently pry it back. **UNLOCKING THE CASTER:** Place the tip of your shoe below the tab and lift up.

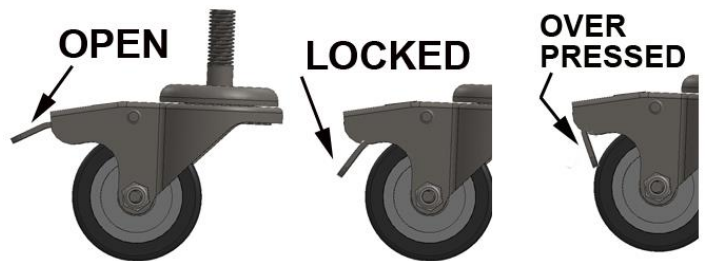

Fig. 4

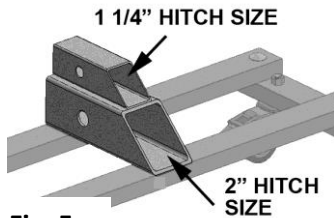

Fig. 5

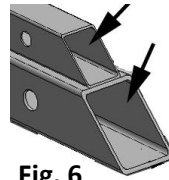

Fig. 6

OPENINGS ARE OVERSIZED FOR EASY INSERTION OF BIKE RACK INTO RACK VALET



Fig. 7

General Notes: Per Fig. 5: The Rack Valet will accommodate both 1.25” and 2” hitch sizes. Use the upper opening for 1.25” and lower opening for 2” hitch tubes. Per Fig. 6: The openings are slightly oversized for easy insertion of the bike rack into the Rack Valet. The bike rack may seem to be a little “wobbly” but it actually is very stable.

Per Fig. 7: For safety reasons, never step or stand on the support legs of the Rack Valet.

Using the Rack Valet: Step 1: Fold the bike rack as if it were flat against the back of your car. **Step 2:** Lock all four casters per Fig. 5. **Step 3:** Insert the bike rack into the Rack Valet. **Step 4:** Install hitch pin. **Step 5:** Unlock the casters and roll the Rack Valet to its destination. If on a downward slope or hill, do not release the Rack Valet and rack until the casters are locked. Before removing bike rack from Rack valet, be sure to lock the casters.

Never step or stand on the support legs of the Rack Valet. For 2+2 style hitch racks (i.e. Hollywood Sport Rider 4), first install the base 2 bike rack into the Rack Valet, then install the outer 2 bike add-on into the base rack.

shown with Hollywood model TRS

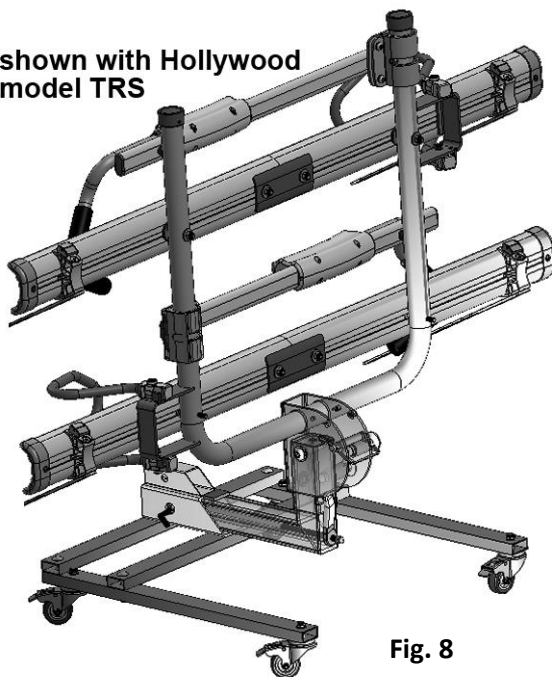

Fig. 8

SHOWN WITH HOLLYWOOD SPORT RIDER 4



INSTALL 2 BIKE ADD ON KIT AFTER BASE RACK HAS BEEN INSTALLED

Fig. 9

HOLLYWOOD RACKS Los Angeles, California
 Family owned and operated since 1973
 For customer service, please email us at
 info@hollywoodracks.com or
 Call 800-747-4085 M-F 8:00 AM – 3:00 PM PST

For warranty information, please visit
www.hollywoodracks.com/about
 Rack Valet™ Patent Pending Model# RV1
 V3 022417
www.hollywoodracks.com