

HOLLYWOOD RACKS

Tow 'n Go Hitch Rack Model HR135 For 2" hitches only

Assembly and Use Instructions for Traveler Style Tow 'n Go Hitch Rack

- Drive slowly when using the rack on bumpy or dirt roads.
- Check the rack bikes and straps regularly during use.
- If you have any questions or installation problems, please see your Hollywood Racks retailer or contact Hollywood Racks at 800-747-4085.

Class III Hitch Required if you tow and carry bikes at the same time. A longer hitch ball mount may be required for use of this product. (Tow N' Go requires 3" of space on your hitch ball mount insert tube)

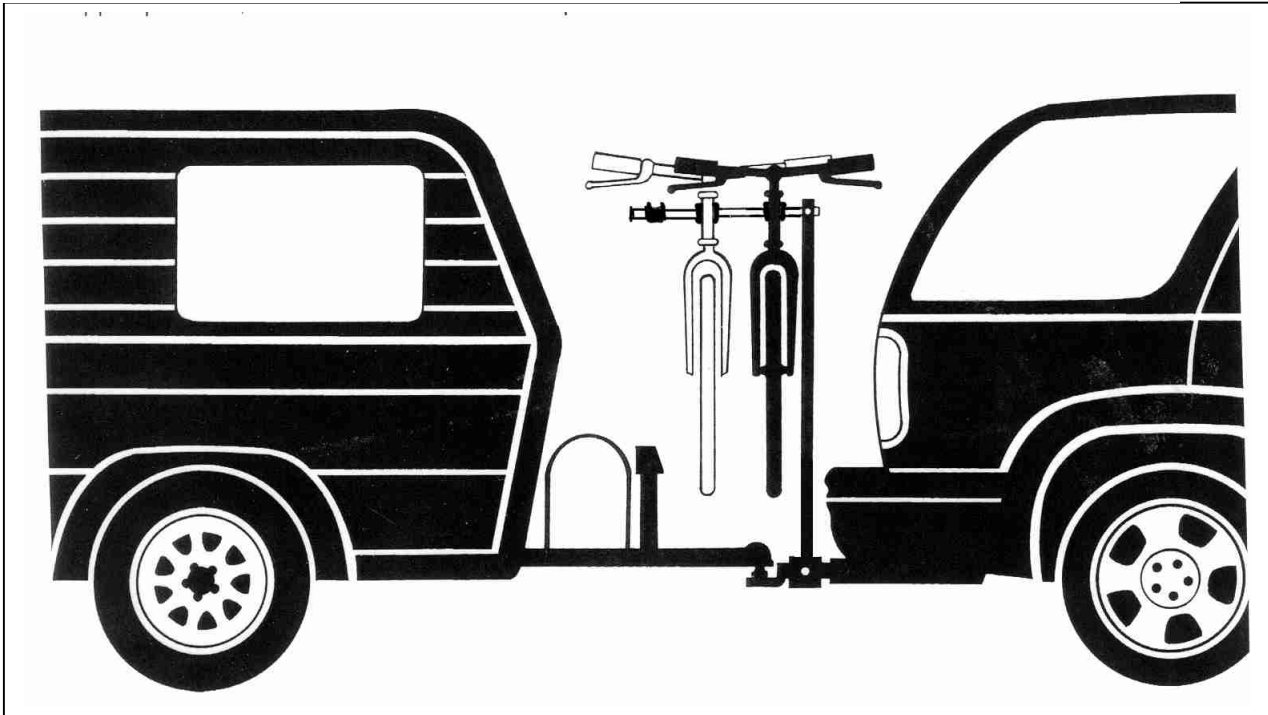

Note: This product not to be used on the back of trailers!



2009 version

Qty	Description
1	Tow 'n Go bike rack with Tie Down strap attached to rack
9	Rubber Bike Cradle straps
1	Allen wrench for set screws

Installation Instructions:

1. Install your trailer hitch receiver tube through the base of the rack (at the bottom of the main beam. See Fig. 1
2. Locate the base as far forward as possible.
3. Using Allen wrench supplied, tighten the 4 set screws on the base unit until snug.

Support Arms (Fig. 2.1)

Rotate the support arm and align the plate holes with the tube holes per Fig. 2a. Insert pin and close safety clasp over pin end. To return the support arm to it's folded position, undo the safety clasp, then hold the arm with one hand and remove the pin so the arm doesn't drop quickly). Re-insert the pin per Fig. 2b.

Caution when using this rack and NOT towing!

This bike rack can also be used when not towing, however your trailer hitch receiver tube (or "stinger") is most likely not to include an anti-wobble device. An anti-wobble device such as a threaded hitch pin is intended to keep the rack stable during use. Hollywood Racks strongly recommends that you either purchase an "after market" anti wobble device for your hitch or use some tie-down straps to secure the rack to the vehicle to prevent any rack movement. If you have any questions on how to do this, please call us at 800-747-4085.

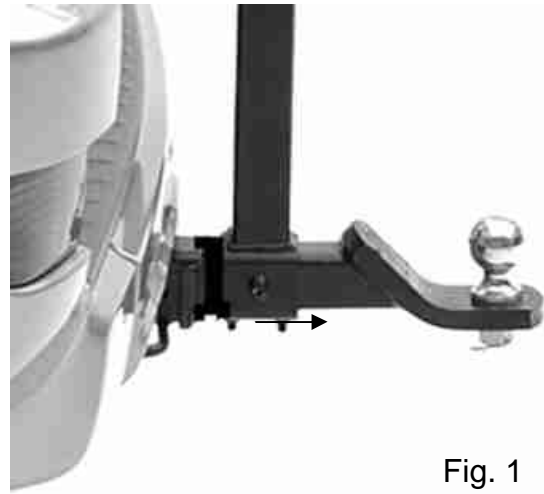

Fig. 1

Fig. 2a



"in-use" position

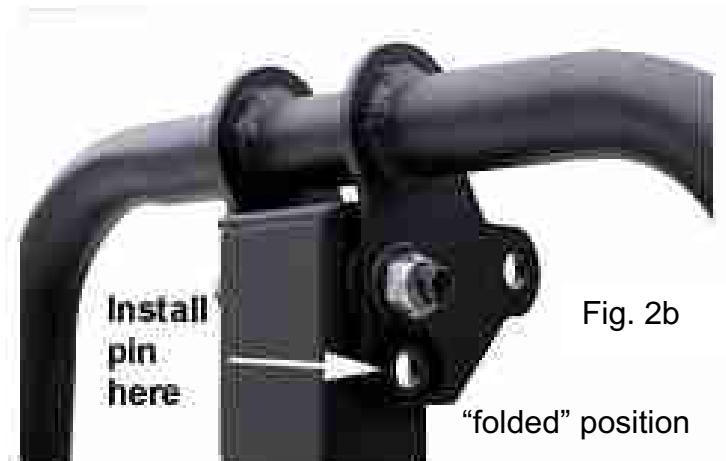

Fig. 2b

"folded" position

2006 through 2008 version

After opening the Tow N' Go box, you should have the following parts:

1. Parts bag including:
 - a. Two black threaded knobs
 - b. Two pivoting spacer blocks
 - c. Allen wrench for set screws.
2. Upright "T" shaped main beam
3. Two Support arms with bike separators attached.
4. Nine rubber straps & Safety tie-down strap

FIG. A: Black threaded knob and spacer block



Fig. B Vertical Cylinder

Installing the support arms:

Insert the knob through the spacer as shown in Fig. 1 (the knob should be against the flat end of the spacer block). Align the threaded hole in the vertical cylinder (fig. 2) so that it faces out. You can rotate the vertical cylinder using a coin or flat blade screwdriver in the slot at the top of the vertical cylinder. Insert the knob through the support arm, and thread the knob into vertical cylinder inside the main top horizontal tube. Repeat for the Driver's side arm.



Caution when using this rack and NOT towing!

This bike rack can also be used when not towing, however your trailer hitch receiver tube (or "stinger") is most likely not to include an anti-wobble device. An anti-wobble device such as a threaded hitch pin is intended to keep the rack stable during use. Hollywood Racks strongly recommends that you either purchase an "after market" anti wobble device for your hitch or use some tie-down straps to secure the rack to the vehicle to prevent any rack movement. If you have any questions on how to do this, please call us at 800-747-4085.

Installation of bikes – all versions

For ease of installation, we suggest you put the larger bikes on the inside (closest to vehicle), smaller frames or kids bikes on the outside. The first bike loaded should have the handlebars facing towards the driver's side of the vehicle. Place the top tube (or closest appropriate frame tube) onto the bike cradles, pull the straps over the bike tube and attach to the tab on the opposite side of the cradle. Use a strap notch-hole that provide a snug fit, but take care not to pull the strap over-tight. This can put undue stress on the bike's paint, and may overstretch the strap, making it more susceptible to breakage. Be sure to use the anti-sway blocks to strap the bikes seat tube (or other frame tube as appropriate) to prevent the bikes from swaying on the rack. The anti-sway pivot block can be removed with either Phillips screwdriver or 5mm hex wrench (depending on fastener used by factory).

If you can't mount the bikes top tube onto the cradles, use the down tube or seat tube. Secure the bike with the cradle straps. Please note that the cradles can be rotated on the support arm to place them in a more easily useable position, and to accommodate unique bicycle frame designs.

VERY IMPORTANT! Use the long (86") tie-down strap (attached to the rack) by placing it through the front and rear wheels of all bikes mounted (this keeps the wheel from spinning while in transit). Wrap the Safety strap around the main beam of the rack after passing it through the wheels of the bikes. Secure the strap by placing the end through the center slot in the buckle, then around the bend and out through the outer slot. Pull on the end of the strap until snug.

Don't Forget!



Note:

Use **Anti-sway blocks** to keep bikes stable while vehicle is in motion. Be careful not to over-stress the straps!

Removing the bikes and rack:

To remove bikes, simply undo the rubber straps and gently lift bikes off. Be sure to fold down the support arms so as to minimize the length of the rack when not in use. To remove the rack from vehicle, remove hitch pin and slide rack out of receiver hitch.

Avoid sharp backup angles when carrying bikes!

Be aware that your bike's wheels may be damaged when backing up at extreme angles. The easiest way to avoid this is to have the bikes high enough to "clear" your propane tanks or other part of the trailer, and to be aware of the distance your bikes take up behind your vehicle.

Limited Lifetime Warranty (effective on racks sold after January 1, 2008):

Hollywood Racks will warrant its car racks and accessories during the time that an original retail purchaser owns the product subject to the exclusions and limitations of this warranty. Hollywood Racks will remedy defects in materials and workmanship by repairing or replacing (at its option) a defective part or the complete rack without charge for labor or parts. Hollywood Racks may elect (at its option) to issue a refund equal to the purchase price paid for the product.

This warranty does not cover problems caused by normal wear and tear including (but not limited to) weather, scratches, dents, rust, accidents, unlawful vehicle operation, misuse, abuse, neglect, theft, unauthorized modifications, or unauthorized repair. No warranty is given for defects resulting in incorrect assembly, incorrect installation onto the vehicle, installation on a "no fit" vehicle, incorrect attachment of bicycles onto the rack, or overloading of the rack's weight restrictions. This warranty terminates if the original retail purchaser transfers the product to any other person. This product is intended for use on 2" class 3 hitches only, and not to be used on any trailer as shown above. Do not exceed vehicle's tongue weight capacity (refer to your trailer hitch owners manual)

If a product is believed to be defective, the original retail purchaser should contact either the original retailer or Hollywood Racks directly at 800-747-4085 or at info@hollywoodracks.com

Disclaimer of Liability: Repair or replacement of a defective product or the issuance of a refund or credit (as determined by Hollywood Racks) is a purchaser's exclusive remedy under this warranty. Damage to a purchaser's vehicle, cargo, bicycles and or to any other person is excluded. This warranty is expressly made in lieu of any and all other express warranties, whether oral or written.

Hollywood Racks shall not be liable for any direct, indirect, consequential, incidental, special, punitive or any other damages in connection with the purchase, use or handling of this product. Some states do not allow the exclusion or limitation of consequential or incidental damages and the above limitation may not apply to you. This warranty gives you specific legal rights and you have other rights, which vary from state to state.

Hollywood Racks

12812 South Spring Street Los Angeles, CA 90061
Tel (800) 747-4085 (310) 516-8600 Fax (310) 516-8955
Customer Service Hours: 7:00 AM - 3:00 PM PST M-F
info@hollywoodracks.com www.hollywoodracks.com
Made in Taiwan 120808 Rev D