

Hollywood Racks

Trike Adapter Model #2 Assembly and installation instructions

Fits Hollywood Racks Sportrider model HR1450R

Not to be used on any trailer, fifth wheel or vehicle being towed by another vehicle

Weight Limit: 135 lbs

Not warranted to be used for carrying electric or motorized bicycles/tricycles or motorcycles

BIKE RACK PARTS LIST

Item	Description	Qty
A	vertical post	1
B	base assembly	1
B1	Front Cap	1
C	short hook clamp	1
D	"Z" hook clamp	1
E	left wheel holder*	2
F	right wheel holder*	2
G	pivot bolt	1
H	receiver tube	1
I	pivot nut	1
J	pivot washers	2
K	locking hitch pin	1
L	security cable	1
M	wheel support tube	4
N	extension lever	1
P	"stop" screws	4
R	clip	2
S	Small Wheel Adapter	2
T	hex key	1
U	Tie down straps	2

*Extra wide for recumbents

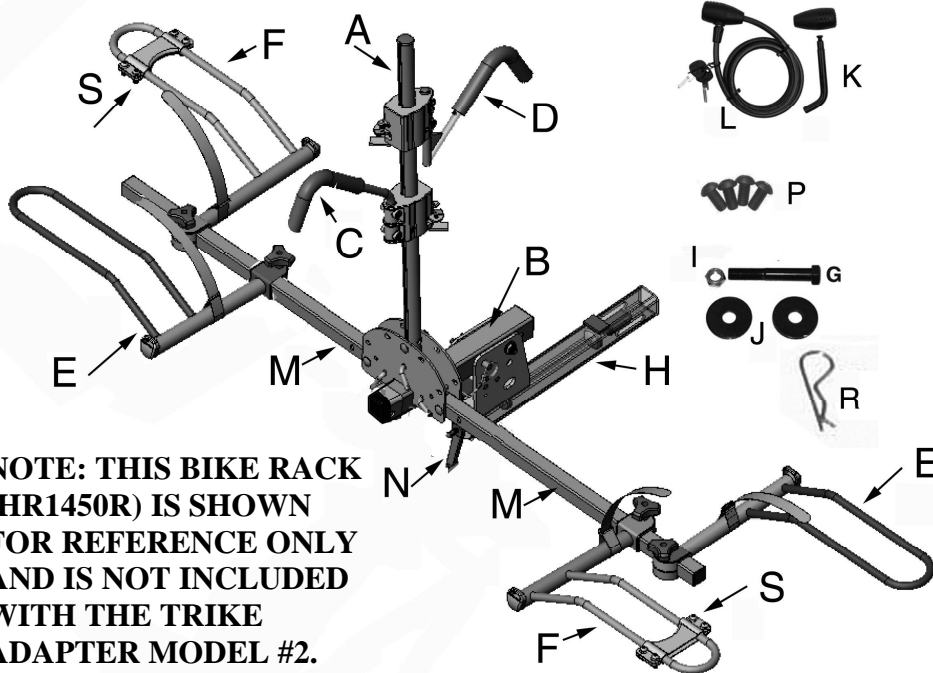

NOTE: THIS BIKE RACK (HR1450R) IS SHOWN FOR REFERENCE ONLY AND IS NOT INCLUDED WITH THE TRIKE ADAPTER MODEL #2.

(The Trike Adapter Model # 2 is included with the Hollywood-Sunlite® Model HRT220).

TRIKE ADAPTER PARTS LIST

Item	Description	Qty
TA-1	straight tube	1
TA-2	long connector	1
TA-3	medium connector	1
TA-4	short connector	2
TA-5	universal connector	1
TA-6	cross connector	1
TA-7	front main bracket	1
TA-8	left side wheel holder*	1
TA-9	small wheel adapter	1
TA-10	safety flag	1
TA-11	tie down straps	2

*standard width

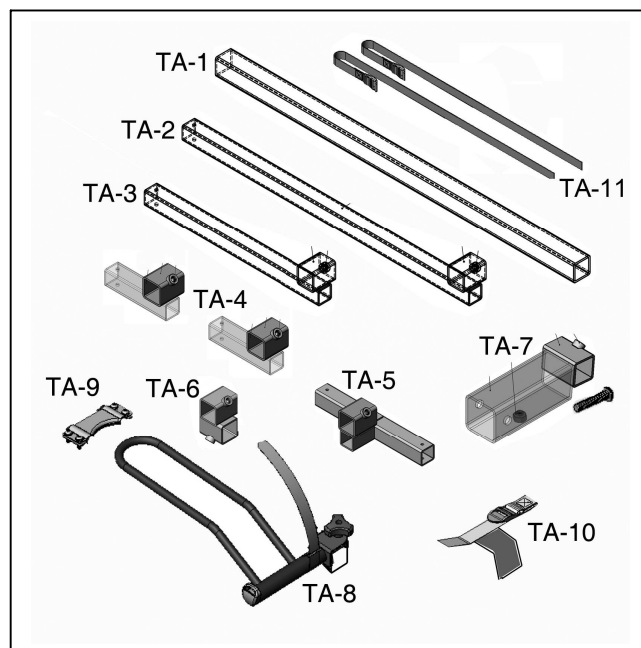

Trike Adapter: Assembly for carrying one trike

TRIKE ADAPTER PARTS LIST

Item	Description	Qty
TA-1	straight tube	1
TA-2	long connector	1
TA-3	medium connector	1
TA-4	short connector	2
TA-5	universal connector	1
TA-6	cross connector	1
TA-7	front main bracket	1
TA-8	left side wheel holder	1
TA-9	small wheel adapter	1
TA-10	safety flag	1
TA-11	tie down straps	2

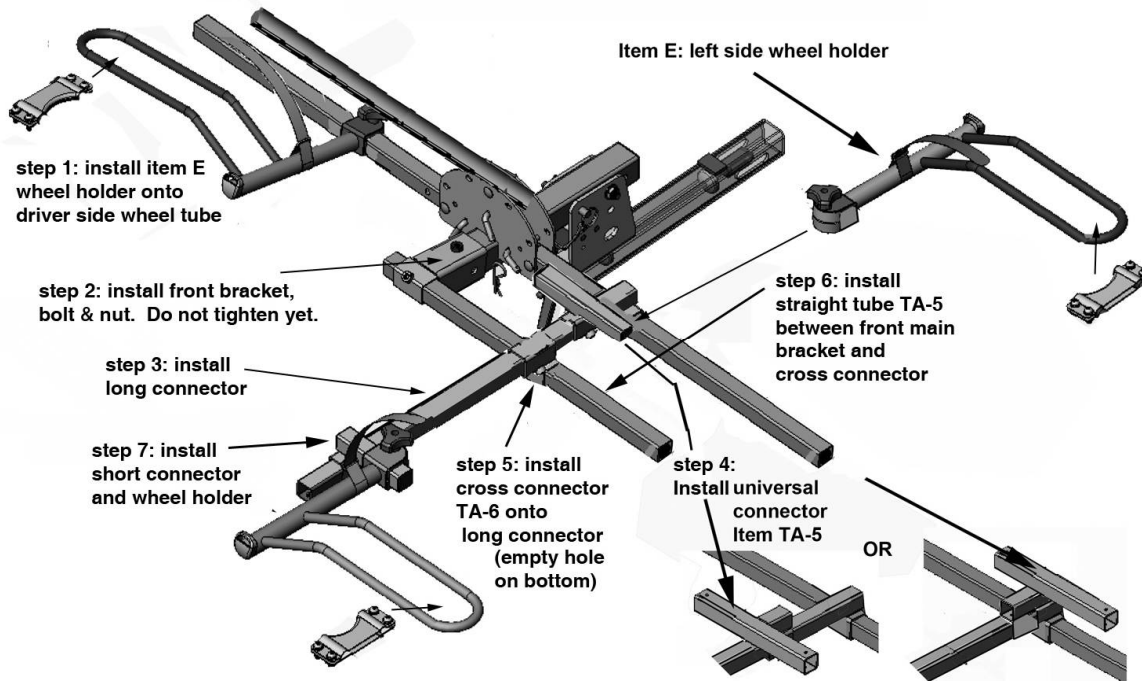
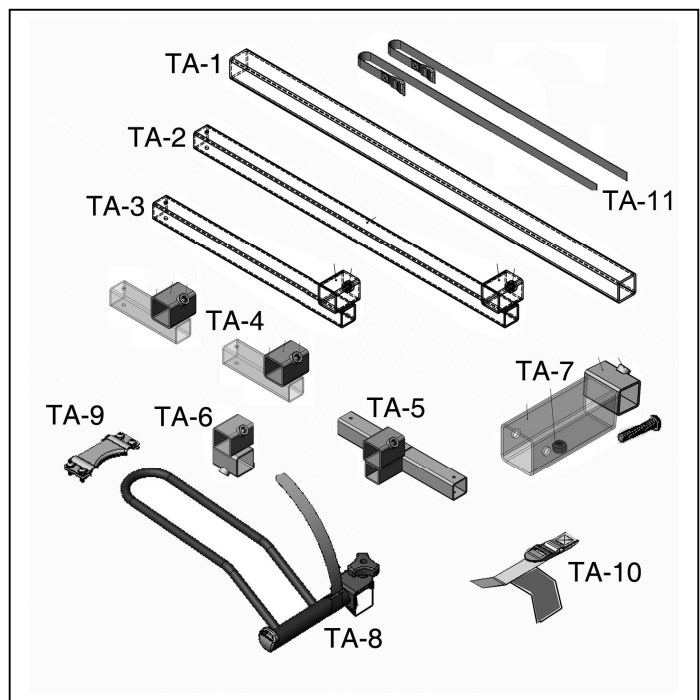

A) Assembly: Install rack on vehicle without wheel holders, center mast must be folded down.

1. Install item E left side wheel holder onto driver's side wheel tube.
2. Remove front reflector cap and install front main bracket **TA-7**. Do not tighten set screw on bottom yet.
3. Slide long connector **TA-2** onto passenger side wheel tube.
4. Install universal connector onto long connector **TA-2**. (Please note it may have to be reverse later depending on the width between the trikes wheels.)
5. Install cross connector **TA-6** (empty hole on bottom) onto long connector **TA-2**
6. Install straight tube **TA-1** between front main bracket and cross connector.
7. Install short connector **TA-4** onto long connector.

Note: when carrying one three wheeler only, the medium connector TA-2 and one of the short connectors TA-4) will not be required.

B: Carrying one "Tadpole" style trike

Tip: the small wheel adapters must be used on 16" wheels, but we also suggest using them on 20" wheels as well for better clearance between the trike's frame and the rack.

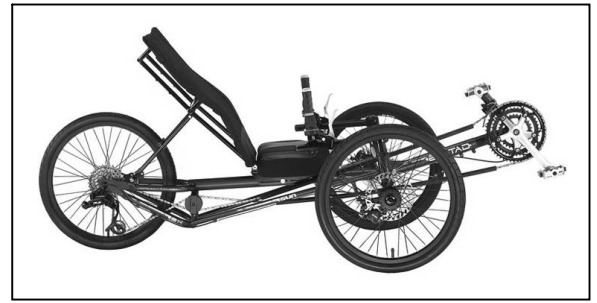

Installation procedure:

1. Measure width between center of tires (track) and distance between center of hubs (wheelbase).
2. Place bike directly behind rack (rear wheel on driver's side), then "center" the trike between vehicle's side view mirrors.
3. Slide the long connector along passenger side wheel tube so it is a few inches behind front wheels.
4. If the center plate is preventing the long connector from positioning behind the front wheels, try rolling the trike a little to the right.
5. **Check to make sure your chain rings are not protruding beyond your side view mirror.**
If you are sticking out too far on the right, please see SETUP "B".
6. Universal connector: *If the track is less than 29", use position B1 shown below. If the track is 29" or more, use position B2 shown below.*
7. Install item E left side wheel holder. For very narrow tracks, you can use item TA-9 wheel holder.
8. Using the measurements taken in step 1, adjust for the track and wheelbase.
9. Place the trike onto the wheel holders to make sure it is sitting correctly in the wheel holders.
10. When the final positions are determined, remove the trike from the rack and **tighten all set screws and knobs securely**. Install stop screws into wheel holders (Fig. 2D) and install the connector tube hardware.
11. When carrying the trike, be sure to use the velcro straps for the wheels AND both tie down straps (TA-11) to secure the trike to the rack. Install the safety flag to the outside front wheel.

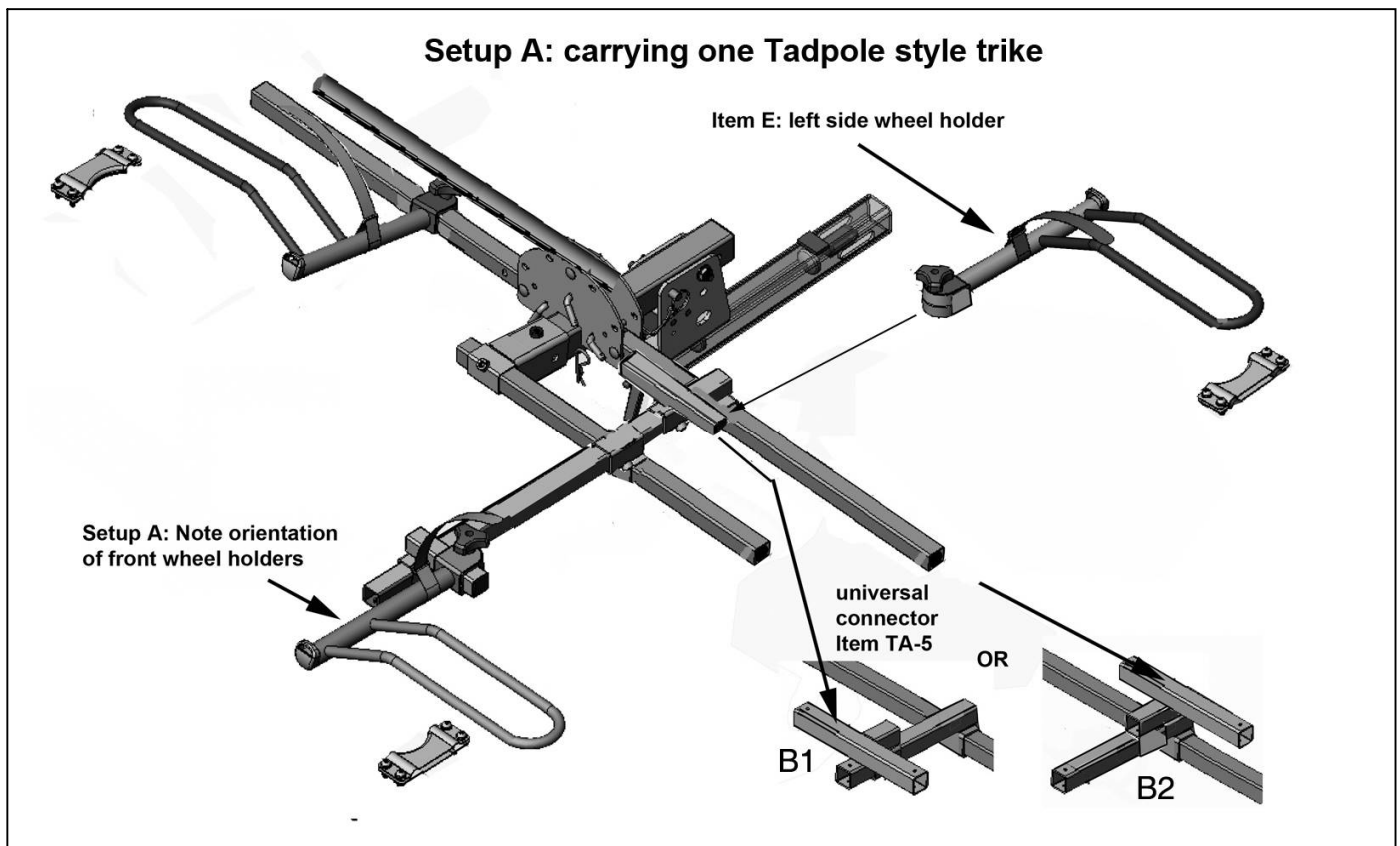

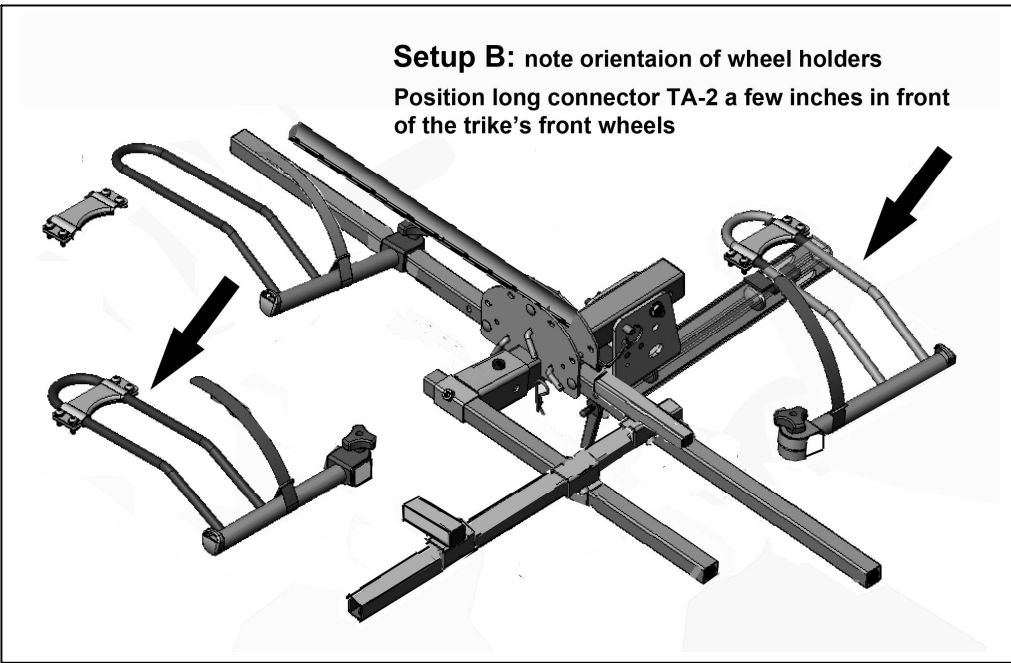

C: Carrying one “delta” style or adult trike

Follow the same installation procedure on page 7 for tadpole style trikes, except have the center mast on the bike rack in a vertical position. Use either the standard or “Z” style hook to clamp down on the frame depending on frame height. Please follow frame clamping procedure as described in section 4, page 4.



Special notes for carrying adult bikes

Due to awkward weight distribution and short wheel base for adult trikes, the distance between the long connector and center of rack should be very small (as small as possible). This will allow the heaviest part of the rack to be as close to the base assembly as possible. The trike will probably not be centered behind the car, so check to make sure the front wheel is not protruding beyond the side view mirror.



(D) INSTALLING TRIKE ADAPTER: CARRYING ONE TRIKE AND ONE "TWO WHEELER"

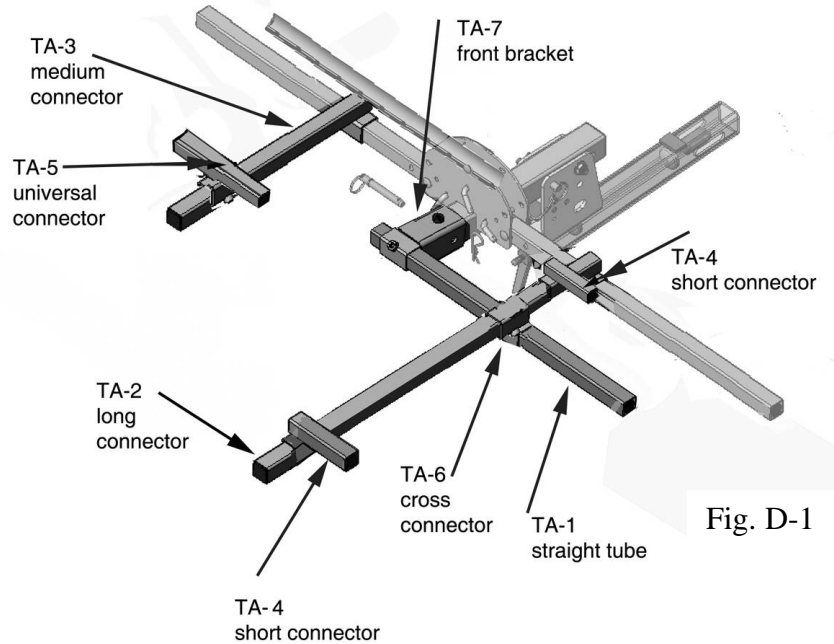
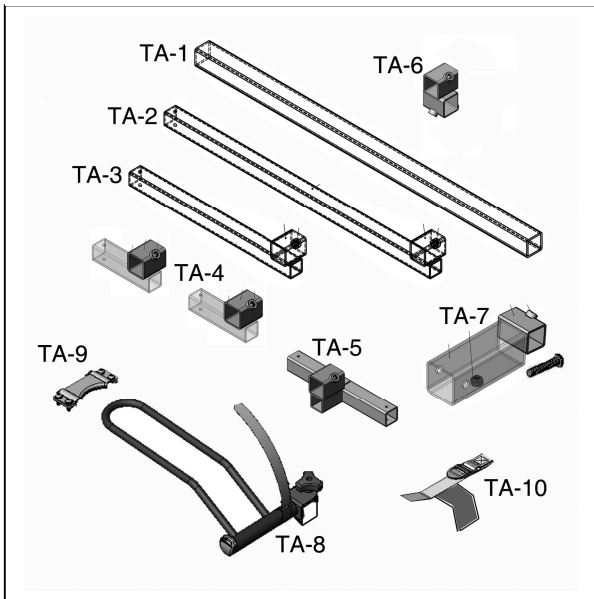

Fig. D-1

Trike Assembly & setup (Different than section B)

Slide medium connector tube **TA-3** onto driver's side wheel holder. Then slide the universal connector **TA-5** onto the medium connector. Install the wheel holder **TA-8** onto universal connector. **Refer to Fig. D-1**

Remove front reflector cap and install front main bracket **TA-7**. Do not tighten set screw.

Slide the long connector **TA-2** onto the passenger side wheel tube. Slide short connector **TA-4** onto long connector so it is close to the passenger side wheel tube. Next, slide the cross connector **TA-6** onto the long connector, "empty hole" on bottom.

Install the straight tube between the cross connector and front bracket. Slide the other short connector onto the long connector, then install the wheel holders onto the short connectors.

Measure width between center of tires (track) & distance between center of hubs (wheelbase). Place bike directly behind rack (rear wheel on driver's side), then "center" the trike between vehicle's side view mirrors. Check to make sure your chain rings are not protruding beyond your side view mirror. If you are protruding too far on the right, please see SETUP "B" (Fig. D-3). Note wheel holder orientation.

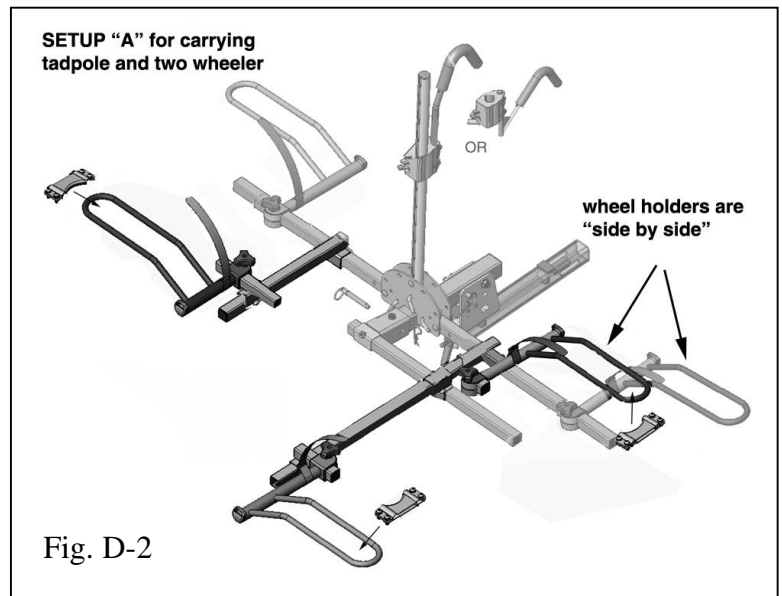

Fig. D-2

Using the measurements taken in step 1, adjust for the track and wheelbase. Place the trike onto the wheel holders to make sure it is sitting correctly in the wheel holders. When the final positions are determined, remove the trike from the rack and tighten all set screws and knobs securely.

When carrying the trike, be sure to use the Velcro straps for the wheels AND both tie down straps (**TA-11**) to secure the trike to the rack. Install the safety flag to the outside front wheel. Install stop screws into wheel holders (Fig. 2D) and install the connector tube hardware.

Installing the bike:

The two wheel bike, (whether it is a recumbent or standard bike) will sit between the tadpole and vehicle. When setting up the trike adapter, be sure to slide the inside short connector "outwards". See fig. D-2 and D-3 so that the wheel holders can be set up "**side by side**" if necessary (Fig. D-10)

The universal connector mounted may be rotated to provide more "outward" distance if necessary. See Fig. D-6

Note Fig. D-4: The wheel holders are pointing inwards. **This allows for installation of standard bikes** or shorter wheel base recumbents so you don't have to tear down the trike setup. Fig. E-3 shows setup for tadpole plus long wheel base recumbent.

SETUP "B" FOR TADPOLE AND TWO WHEELER

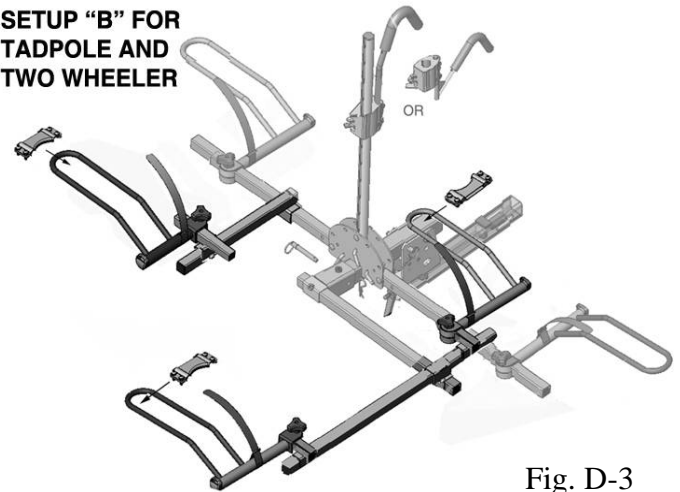

Fig. D-4

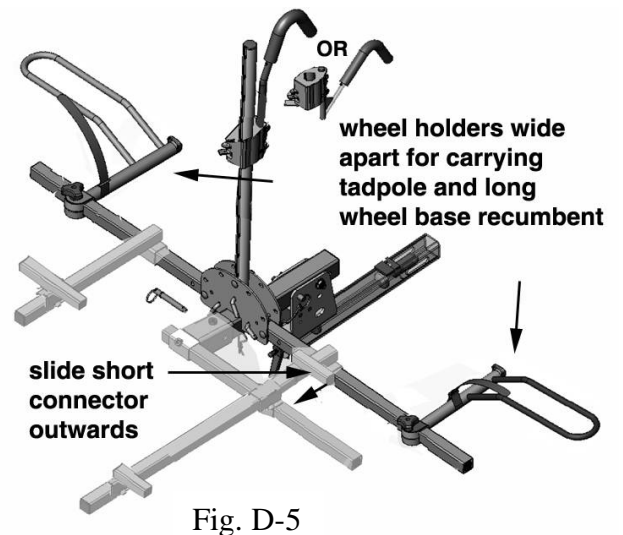
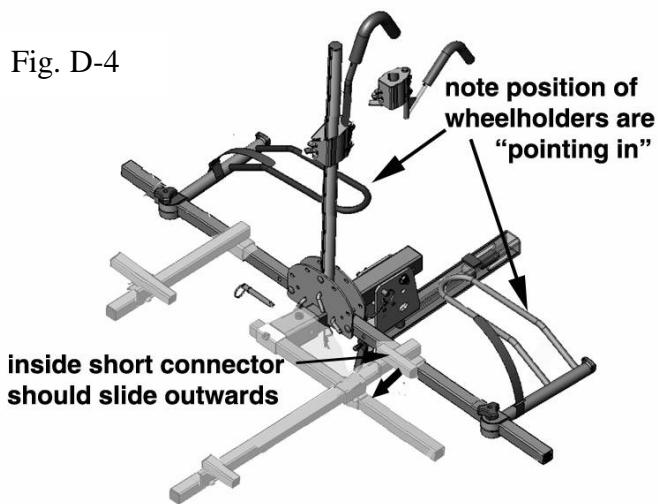
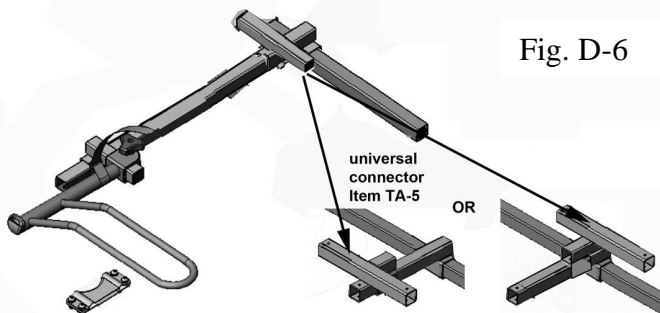

Fig. D-6



CARRYING A DELTA TRIKE AND BIKE

If carrying a delta trike and a bike, it will probably not be possible to use the center mast/frame hook on the trike due to the track width and interference with the inside bike. In this case, follow the procedures given in the previous section on tadpoles and use the center mast/frame hook for the inside bike.

Fig. D-7

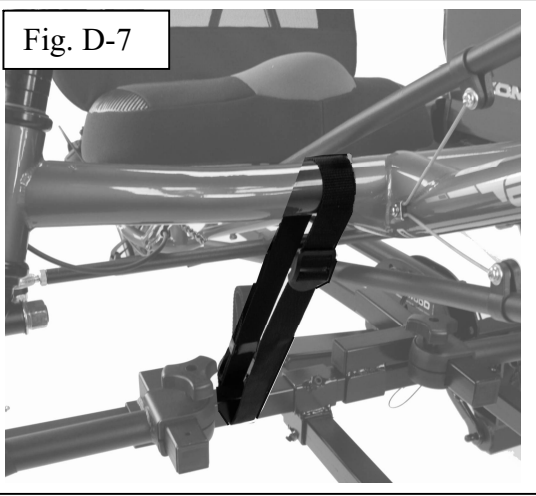

Fig. D-7: It is very important to use the tie downs (item TA-11) to secure the trike to the rack due to its high center of gravity. Use additional tie downs as required.

Fig. D-8A shows the setup for carrying just one 3-wheeler,
Fig.D-8B shows same setup with tadpole installed.

Fig. D-9A shoes setup for carrying one trike and one bike,
Fig. D-9B shows with one bike installed and

Fig. D-9C (next page) shows with both bike and trike installed.

Fig. 10: "Side by Side" wheel holders

Fig. D-8A



Fig. D-8B



Fig. D-9A

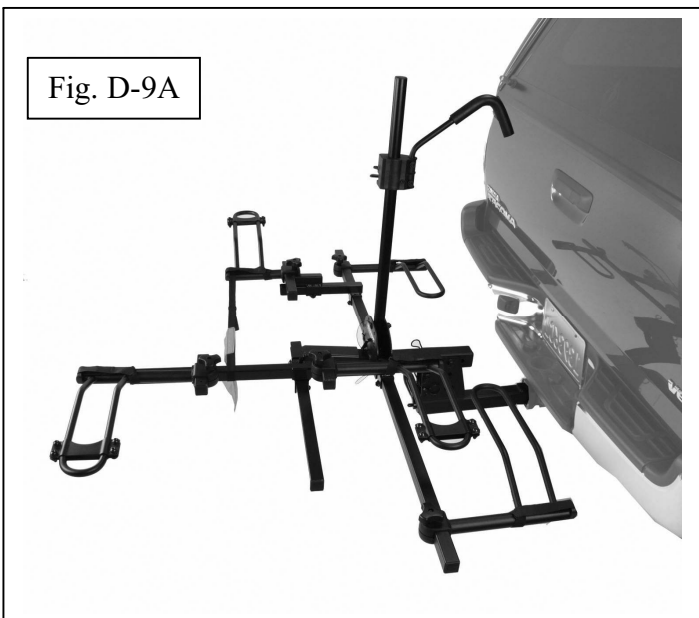

Fig. D-9B

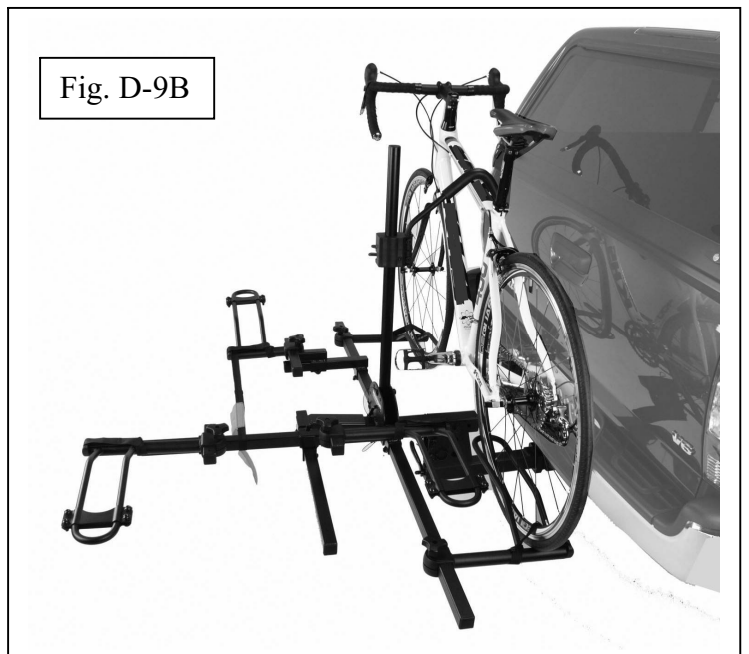

Fig. D-10



Note “side-by – side” position of wheel holders when carrying one bike and one trike (Fig. D-10).

Fig. D-9C



Hollywood Racks

Limited Lifetime Warranty (effective January 1, 2008):

Hollywood Racks will warranty its car racks and accessories during the time that an original retail purchaser owns the product subject to the exclusions and limitations of this warranty. Hollywood Racks will remedy defects in materials and workmanship by repairing or replacing (at its option) the complete rack or a defective part without charge for labor or parts. Hollywood Racks may elect (at its option) to issue a refund equal to the purchase price paid for the product.

This warranty does not cover problems caused by normal wear and tear including (but not limited to) weather, scratches, dents, rust, accidents, unlawful vehicle operation, misuse, abuse, neglect, theft, unauthorized modifications, or unauthorized repair. No warranty is given for defects resulting in incorrect assembly, incorrect installation onto the vehicle, installation on a “no fit” vehicle, incorrect attachment of bicycles onto the rack, or overloading of the rack’s weight restrictions. This warranty terminates if the original retail purchaser transfers the product to any other person.

If a product is believed to be defective, the original retail purchaser should contact either the original retailer or Hollywood Racks directly at 800-747-4085 or at info@hollywoodracks.com

Disclaimer of Liability: Repair or replacement of a defective product or the issuance of a refund or credit (as determined by Hollywood Racks) is a purchaser’s exclusive remedy under this warranty. Damage to a purchaser’s vehicle, cargo, bicycles and or to any other person is excluded. This warranty is expressly made in lieu of any and all other express warranties, whether oral or written.

Hollywood Racks shall not be liable for any direct, indirect, consequential, incidental, special, punitive or any other damages in connection with the purchase, use or handling of this product. Some states do not allow the exclusion or limitation of consequential or incidental damages and the above limitation may not apply to you. This warranty gives you specific legal rights and you have other rights, which vary from state to state.

Hollywood Racks
12812 S. Spring St. Los Angeles, CA 90061
Tel (310) 516-8600 (800) 747-4085 FAX (310)516-8955
www.hollywoodracks.com email: info@hollywoodracks.com
Customer Service Hours: M-F 8:00AM to 3:00 PM PST

Made in Taiwan
V1 122011